

Solutions for Power, Control, Safety & Energy Efficiency



POWER
SWITCHING



POWER
MONITORING

2022

When **energy** matters



When **energy** matters

Contents

An independent manufacturer p. 4
 Your energy, our expertise p. 6
 Experts at your service p. 8

Expert in power conversion p. 10
 A cutting-edge laboratory p. 11
 References list p. 514



Load break switches

Load break switches for machine control, power distribution and photovoltaic applications ... p. 13



SIRCO M and SIRCO MV
p. 22



SIRCO and SIRCO AC
p. 40



Fuse protection

Fuses, fuse bases and fuse combination switches p. 129



FUSERBLOC
p. 134



FUSERBLOC LMDC
p. 162



Changeover switches

Changeover switches, control relays and configuration software p. 201



COMO CS
p. 210



SIRCOVER
p. 216



Metering, monitoring & power quality

Energy meters, multifunction meters and supervision software p. 293



DIRIS Digiware
p. 302



TE, TR, iTR, TF
sensors
p. 328



Electronic protection

Differential protection, voltage surge protection, current protection p. 429



RESYS M40
p. 434



Mounting & cabling accessories

All the components to facilitate the use of your electrical equipment p. 441



Busbar supports
p. 442



Distribution blocks
p. 474



Integrated products & solutions

Enclosed protection and switching devices p. 483



Enclosed switches
p. 486



Safety enclosures
p. 502



SIRCO MC PV
p. 62



SIRCO PV
p. 74



INOSYS
p. 98



**SIRCO MOT DC /
SIRCO MOT DC ESS**
p. 110



RMRMS
p. 168



Fuse bases
p. 174



Industrial fuses
p. 180



Photovoltaic
fuses
p. 194



ATyS M
p. 234



ATyS S
p. 248



ATyS
p. 256



ATS controller
p. 286



COUNTIS E
p. 344



DIRIS A
p. 364



DIRIS B
p. 386



Software suite
p. 424



Enclosed
transfer switches
ATyS Bypass
p. 504



Solutions for medical locations
MEDSYS
p. 508

Ensuring the energy performance of electrical installations, wherever it is critical

When **energy** matters



100 years
OF SHARED ENERGY
1922 — 2022

socomec
Innovative Power Solutions



SYDOW 514

For almost 100 years, Socomec has continued to design and manufacture its core products in Europe. Notably solutions for its primary mission: the availability, control and safety of low voltage electrical networks.

As an independent manufacturer, the group is committed to constant innovation to improve the energy performance of electrical installations in infrastructures as well as industrial and commercial sites. Throughout its history, Socomec has constantly anticipated market changes by developing cutting-edge technologies, providing solutions that are adapted to customer requirements and fully in keeping with international standards. "Optimising the performance of your system throughout its life cycle" - this is the commitment carried out every day by the Socomec teams around the world, wherever your business is located.

1
independent
manufacturer

3,500 m²
of test platforms

One of the leading independent power testing labs in Europe

10%
of turnover invested in R&D

Always at the cutting-edge of technology for innovative, high quality products

110,000
on-site interventions per year

Nearly 400 experts in commissioning, technical audit, consultancy and maintenance

Your energy, our expertise



Power switching

Managing power and protecting people, equipment and installations

Active in the industrial switching market since its foundation in 1922, Socomec is today an undisputed leader in the field of low voltage switchgear, providing expert solutions that ensure:

- isolation and on load breaking for the most demanding switching applications,
- continuity of the power supply to electrical facilities via manual remotely operated or automatic transfer switching equipment,
- protection of persons and assets via fusebased and other specialist solutions.

Power monitoring

Improving energy performance and monitoring installations

Socomec solutions - from current sensors to power meters and from IOT to energy management software - are driven by experts in energy performance. They meet the requirements of facility managers and operators of commercial, industrial and critical buildings to enable and facilitate:

- the measurement of energy consumption, the identification of sources of excess consumption and the generation of awareness amongst occupants as to their impact,
- the utilisation of the best available tariffs, utility bill checks and the accurate distribution of energy billing between consumer entities,
- the limitation of reactive energy and avoidance of associated tariff penalties,
- capacity management and the evolution of the electrical installation,
- improvements to power availability by monitoring and detecting insulation faults.

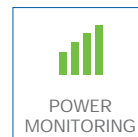



POWER
CONVERSION

Power conversion

Ensuring the availability and storage of high quality power

With its wide range of continuously evolving products, solutions and services, Socomec are recognised experts in the cutting-edge technologies used for ensuring the highest availability of the electrical power supply to critical facilities and buildings, including:

- static uninterruptible power supplies (UPS) for high-quality power free of distortions and interruptions occurring on the primary power supply,
- changeover of static, high availability sources for transferring the supply to an operational back-up source,
- permanent monitoring of the electrical facilities to prevent failures and reduce operating losses,
- energy storage for ensuring the proper energy mix of buildings and for stabilisation of the power grid.

Expert services

Enabling available, safe and efficient energy

Socomec is committed to delivering a wide range of value-added services to ensure the reliability and optimisation of end-users' equipment:

- prevention and service operations to lower the risks and enhance the efficiency of operations, for high-quality power free of distortions and interruptions occurring on the primary power supply,
- measurement and analysis of a wide range of electrical parameters leading to recommendations for improving the site's power quality,
- optimisation of the total cost of ownership and support for a safe transition when migrating from an old to a new generation of equipment,
- consultancy, deployment and training from the project engineering stage through to final procurement,
- performance assessment of the electrical installation throughout the life cycle of the products via analysis of data transmitted by connected devices.

✓
EXPERT
SERVICES





SITE 1059

Your partner in expert services

Socomec is committed to delivering a wide range of value-added services to ensure the reliability and optimisation of end-users' equipment during its life cycle

- Prevention and service operations to reduce risk and enhance equipment efficiency.
- Measurement and analysis of a wide range of electrical parameters leading to recommendations for power quality improvement.
- Consultancy, deployment and training from the project engineering stage to the final procurement stage.



Specialists - at your service

Our Services team comprises qualified engineers whose mission is to ensure the correct operation of your equipment. We offer a comprehensive support service package which gives you complete peace of mind: commissioning, on-site testing, preventive maintenance visits, 24-hour call out and rapid on-site repairs, original spare parts, power quality and energy efficiency audits, consultancy, design and implementation of installation modifications and updates.

Our Services team is the most reliable partner when it comes to advising you on the maintenance of Socomec equipment and providing resolution to any problems in accordance with current environmental standards and procedures.



Professional tools

Our Services team is provided with the latest essential equipment including:

- Personal Protective Equipment (protective goggles, helmet, insulated gloves, fireproof jacket, safety shoes, earplugs...),
- laptop embedded with all software required to optimise equipment performance,
- measuring equipment calibrated annually by our metrology department (multimeter, digital scope, current clamps, infra-red camera, power analyser).



Reports

An exhaustive report is generated for each intervention (including commissioning, preventive maintenance and troubleshooting) which is then automatically sent to the customer and synchronised with our systems.



Remote diagnostics

In case of any anomaly, an automatic notification is sent to a local call centre for proactive online troubleshooting.



Availability of original spare parts

The various original parts and components that we stock guarantee that any faulty equipment can be rapidly brought back online, whilst maintaining its original performance and reliability.

Key figures

Nearly 400 Socomec experts - supported by 200 engineers and technicians from across our distributor network - can provide the solutions to your specific needs.

- Subsidiaries
- Distributors
- Contact us

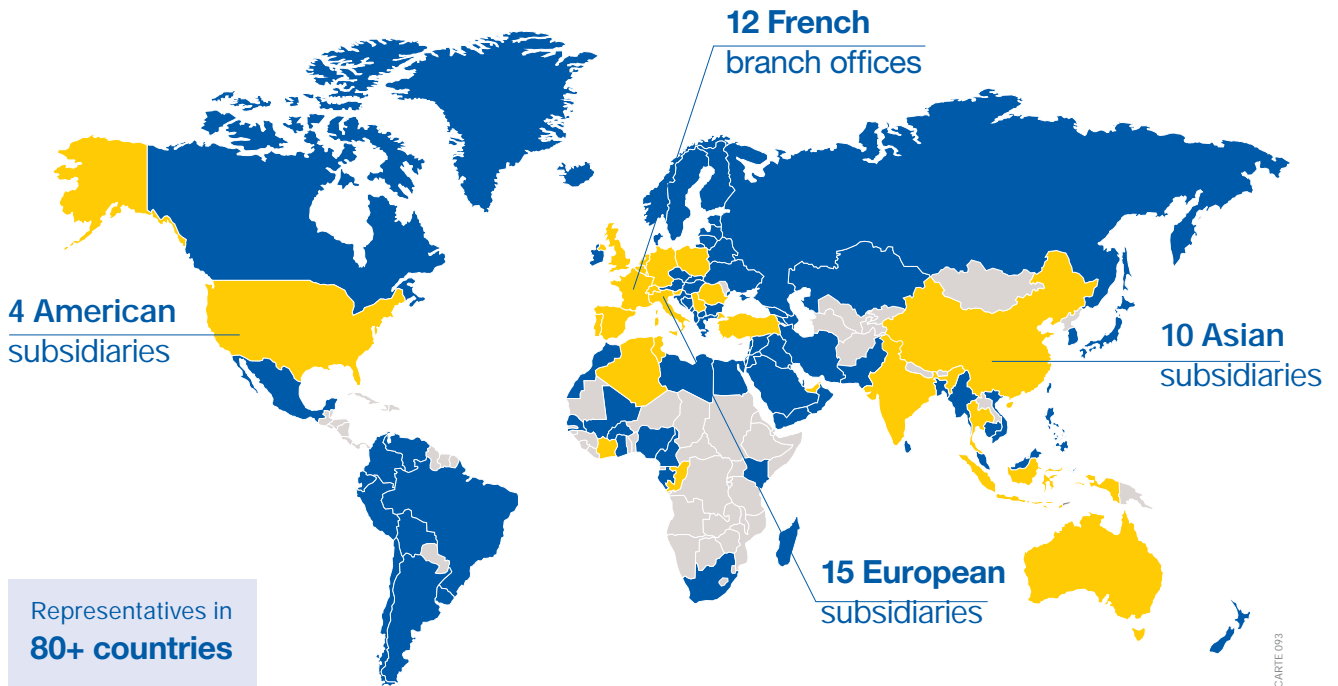

On-site service management



110,000

service operations per year
(mainly preventive visits)

98%

Service Level Agreement
compliance rate

Technical hotline network



25+

languages spoken

3

advanced technical support centres

110,000+

incoming calls handled per year

Certified expertise



8,000

hours of technical training
undertaken every year
(product, methodology and safety)

Expert in power conversion

maximising power quality and availability



Socomec at the forefront of innovation

European design and production
Socomec's products are designed and developed by our talented team of in-house engineers with their real depth and wide knowledge in power electronics and digital controls. Our expertise in manufacturing - combined with the use of only the highest quality components in the most efficient production and testing processes - means that when it comes to reliability our products are unrivaled.

Socomec factories join the digital world
Since 2014, Socomec has been investing to bring its manufacturing facilities in line with industry 4.0 standards. Beyond lean manufacturing, the digitalisation of production means that we can ensure the delivery of a competitive offering with continuously improving service levels whilst also supporting the creation of more personalised products.

Factory Acceptance Test (FAT)
The FAT service is available to all customers who want to audit their order before it leaves the factory. With the support of Socomec Platform Engineers and dedicated infrastructure, several live product tests are available, including:

- standard tests to verify product performance,
- custom tests according to your precise requirements.

3 levels of protection according to your criticality

PRIME
Trustworthy power

Reliable and cost effective protection to assure operational continuity

SUPERIOR
Unrivaled power performance

Best in class & certified performance to optimise usage and Total Cost of Ownership

ULTIMATE
Fault tolerant power without compromise

Fully redundant architecture for maximum availability, minimum MTTR and risk free maintenance

A cutting-edge laboratory

the backing of an expert

Created in 1965, SOCOMEC's laboratory brings its expertise to guarantee the reliability and the conformity of our products and solutions.

Since 2015, the laboratory renamed Tesla Lab – Power Testing and Certification in 2015, offers its testing and certification services to all its customers.

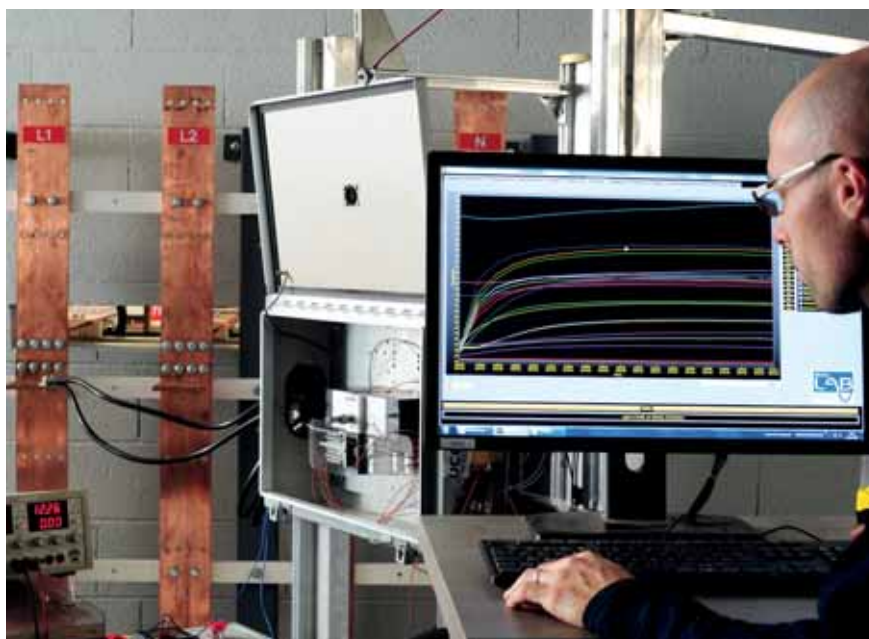
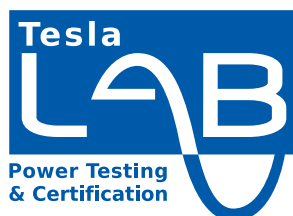

CORPO 441 A

Proven expertise

Tesla Lab is an independant laboratory specialised in testing of LV switchgear, components and switchgear assemblies.

4 M€ has been invested since 2011 in this 2000 m² laboratory, where 30 experts guarantee the quality of the performed tests, making the Tesla Lab one of the most modern laboratories in Europe.

Vast range of tests

The laboratory has a 100 MVA (I_{cc} 100 kA rms 1 s) short-circuit platform, three 10 kA overload platforms and many other test facilities covering 2000 m² for:

- functional tests,
- mechanical tests: endurance,
- dielectric tests,
- environmental tests: vibration,
- Ingress Protection (IP),
- temperature rise tests up to 60 °C ambient.

International partnership

The laboratory is recognised by the major certification bodies worldwide: member of ASEFA and LOVAG, it is accredited by COFRAC, UL (CTDP), CSA (shared certification) and DEKRA (WMT).

The partnership with many international certification bodies guarantees the quality and safety requirements in each country.

Implementation of standard IEC/EN 61439

Electrical switchgear manufacturers

IEC/EN 61439 standards define the requirements of "Low voltage switchgear assemblies" as well as the tests necessary to ensure the achievement of the specified levels of performance. The compliance with these standards gives a guarantee of safety and performance to the user of the equipment



An original manufacturer according to IEC/EN 61439 standards

Socomec offers a wide range of original manufacturer solutions complying with IEC 61439 standards.

- FLEXYS and CADRYS cabinet systems designed for distribution panel applications.
- Local switching and equipment cabinets covering requirements in power availability and safety.
- Components for integration.

Tesla Lab accredited by COFRAC

With its world-class testing facilities, the Tesla Lab can perform all of the tests required by IEC/EN 61439 standards for switchgear assemblies

We can therefore help you to:

- define a verification program,
- perform conformity tests,
- issue test reports in order to get certification from third party certification bodies (ASEFA, LOVAG, DEKRA, UL, CSA, COFRAC, ASTA...).

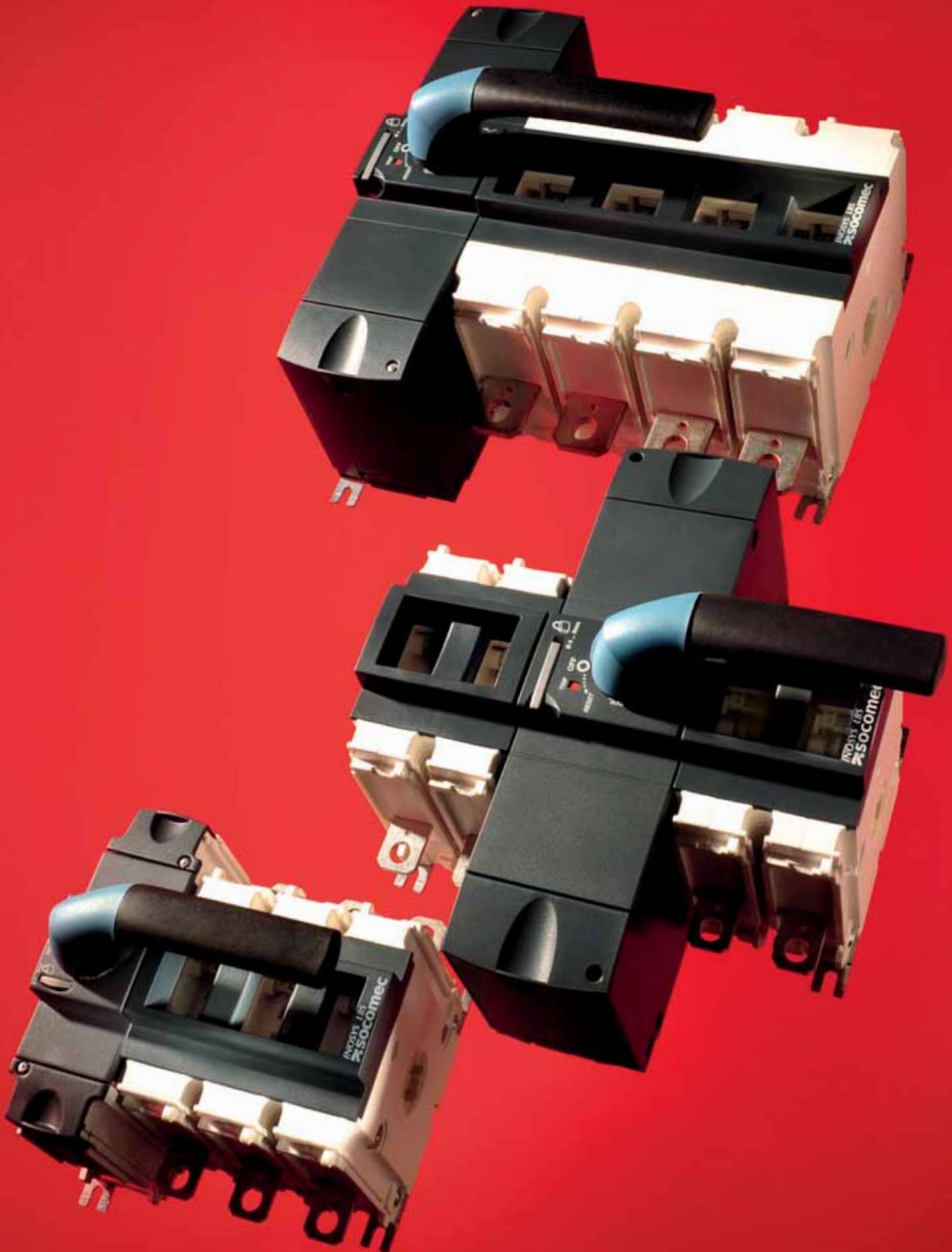

Load break switches

Load break switches for all your applications	<i>p. 14</i>
Why choose a load break switch designed for photovoltaic applications?	<i>p. 15</i>
Load break switch selection guide	<i>p. 16</i>
Photovoltaic load break switches selection guide	<i>p. 18</i>

Load break switches



**SIRCO M and
SIRCO MV**
16 to 160 A
p. 22



**SIRCO
SIRCO AC**
125 to 5000 A
p. 40



INOSYS LBS
160 to 800 A
p. 98

Load break switches for DC and PV applications



SIRCO PV
100 to 3200 A
p. 74



INOSYS LBS
160 to 630 A
p. 98



**SIRCO MOT DC /
SIRCO MOT DC ESS**
250 to 3600 A
p. 110

Specific applications

Load break switches:

- with overrated neutral,
- high short-circuit withstand,
- multipolar,
- for earthing,
- for 1000 V network,
- motorised models.



p. 124

Find out more

Enclosed devices

SOCOMEC offers a range of pre-assembled steel and polyester enclosures.



p. 483

Special requests

SOCOMEC makes specific products.

We will help you to find the best solution for your application.

Contact your local sales office.

Load break switches for all your applications

Machine control, power distribution and photovoltaic installations

Operating in the electrical breaking technology market since 1922, SOCOMEC is both a global leader and unrivalled benchmark reference.

The SOCOMEC load break switches range is one of the largest on the market. INOSYS LBS is the latest range of load break switches especially designed and tested for most demanding applications.

It completes the two lead product ranges in this category: SIRCO M and SIRCO.

If the three ranges INOSYS LBS, SIRCO and SIRCO M cover most needs, the complete range of SOCOMEC load break switches meets every application.

A specific need?

We have developed many customised solutions: switches with overrated neutral, high short circuit withstand, multipolar switches, earthing switches, switches for 1000 V networks, special motorised switches, etc.

Whatever your application, you will find the right solution in the following pages!



appl_312_a

Discover all our products in the selection guides in the following pages.

SOCOMEC load break switches in power distribution and machine control applications

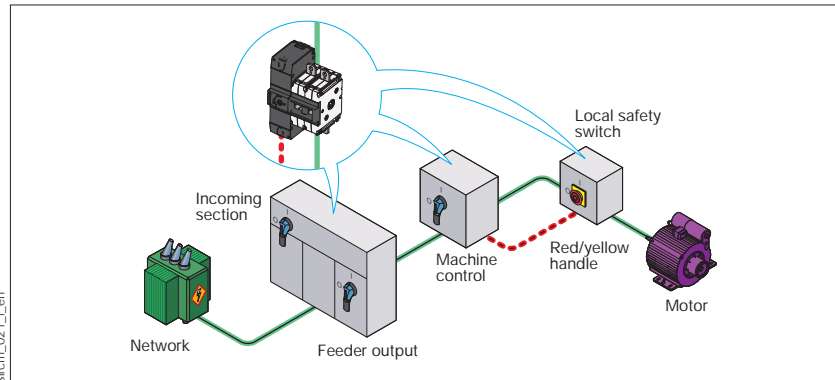

sircm_021_f_en

SOCOMEC load break switches in photovoltaic applications

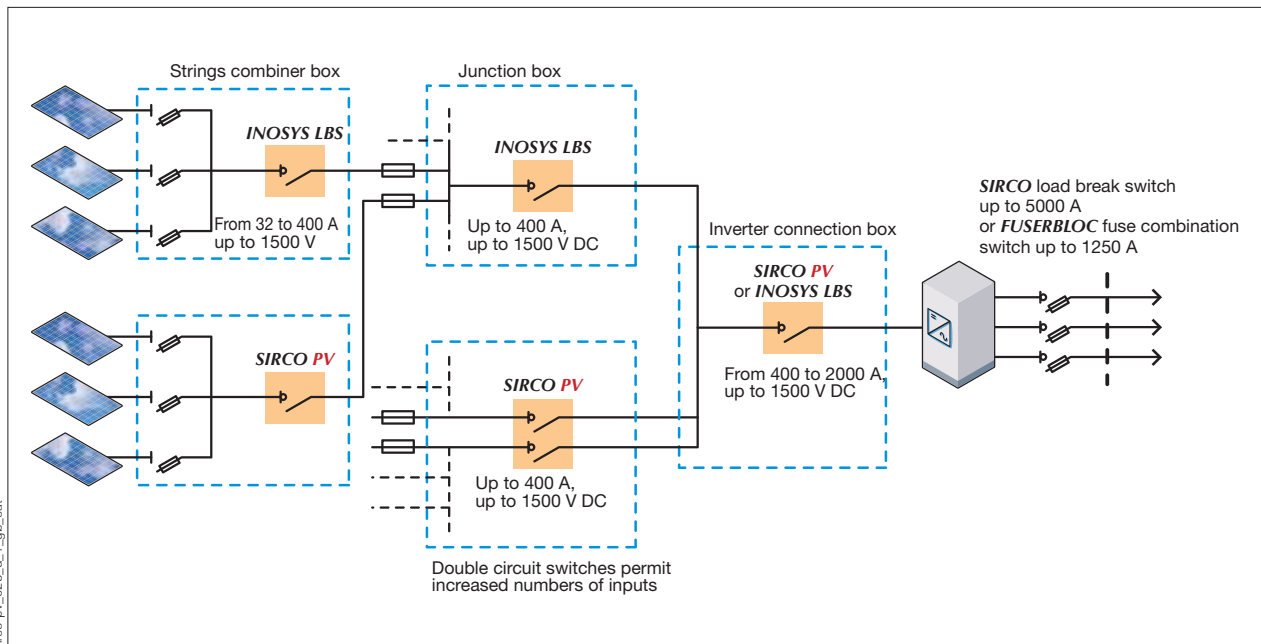

sircopv_028_d_1_gb_cat

Why choose a load break switch designed for photovoltaic applications?



gamme_574

SIRCO MC PV, SIRCO PV and INOSYS LBS devices are available in IEC and UL versions.

Safe operations

To ensure electrical isolation during maintenance operations, or for emergency breaking to prevent a risk of fire or electrical shock, it is essential that dedicated photovoltaic switches are used.

These devices must be installed at each functional level of the installation based on its architecture.

In order to disconnect a direct current photovoltaic string, generator or UPS, only INOSYS LBS, SIRCO PV or SIRCO MC PV devices can:

- Isolate the associated high DC voltages ,
- Guarantee safe on-load disconnection several thousand times across the full range of DC currents linked to daily fluctuations in sunlight, up to 1500 VDC.

Devices designed for extreme conditions

Socomec load break switches have been designed for industrial use. They are extremely robust, with casings made from glass fibre-reinforced thermoset materials, bringing numerous benefits:

- Thermal stability, unlike some thermoplastics,
- Excellent resistance to high temperatures,
- Good electrical characteristics: Arc and insulation resistance,
- Good mechanical characteristics: Dimensional stability and rigidity over time.

These benefits are particularly important in photovoltaic installations, where the temperature may be below 0°C or above 50°C.

Back-to-back design, an innovative solution

The SOCOMEC range of photovoltaic load break switches enables simultaneous on-load disconnection of two circuits using a single handle.

Advantages

- **Space saving:** The overall width is the same as that of 3 or 4 pole devices. This enables significant savings, as compared to the use of two separate devices.
- **Simple connection** and integration.
- **Increasing the voltage:** Connecting the two devices in series allows on-load disconnection of voltages above 1000 VDC.
- **Doubling the rating:** By connecting the two devices in parallel.

What are the standards that apply to photovoltaic installations?

For installations

Photovoltaic installations are governed by international standards such as IEC and UL. These standards provide the guidelines for commissioning a photovoltaic installation.

- IEC 60364-7-712: Electrical installations of buildings — Requirements for special installations or locations — Solar photovoltaic (PV) power supply systems.
- IEC 62548: Installation and safety requirements for photovoltaic (PV) generators.

For breaking devices

To date there is no specific IEC standard.

Manufacturers must therefore refer to standard IEC 60947-3. **In the USA, the reference standard is UL98B.** This standard, which is more stringent than IEC 60947-3, requires strict testing, in particular concerning temperatures and resistance to electrical arcing.

SIRCO PVs have been developed in compliance with both IEC 60947-3 and UL98B.



Selection guide

Load break switches

Which application?



Which function?

	Machine control		
			
	SIRCO M 16 to 125 A <i>p. 22</i>	SIRCO MV 100 to 160 A <i>p. 22</i>	
Applications			
Main switchboard	•	•	
Distribution panel	•	•	
Emergency load break	•	•	
Genset output	•	•	
Network coupling	•	•	
Local safety load break	•	•	
Machine control	•	•	
Enclosed switches	•	•	
Functions			
3/4 pole load break switch	•	•	
6/8 pole load break switch	•		
3/4 pole transfer switch (I-0-II)	•		
3/4 pole transfer switch (I-I+II-II)	•		
Characteristics			
Operation			
Manual (rotating)	•	•	
Manual toggle	•		
Motorised			
Direct operation handle			
Front	•	•	
External operation handle			
Front	•	•	
Right side	•	•	
Left side	•	•	
Indication of breaking			
Positive break indication	•	•	
Visible contacts		•	
Switch body			
Modular	•	•	

(1) Please consult us.

Selection guide

Load break switches

PV applications

Which application?



Which function?

	Photovoltaics	
		
	SIRCO PV IEC 100 to 2000 A <i>p. 74</i>	
Applications		
Emergency load break	•	
Photovoltaic load break	•	
Fitted enclosures	•	
Functions		
3/4 pole load break switch	•	
6/8 pole load break switch	•	
Characteristics		
Operation		
Manual (rotating)	•	
Motorised		
Direct operation handle		
Front	•	
Side		
External operation handle		
Front	•	
Left side		
Indication of breaking		
Positive break indication	•	
Visible contacts		
Switch body		
Modular		

Selection guide



Load break switches

UL products

Which application?



Which function?

	Machine control		Power distribution
			
	SIRCO M UL 508 16 to 80 A <i>p. 22</i>	SIRCO M UL 98 30 to 100 A <i>p. 22</i>	INOSYS LBS UL 98 with tripping function 100 to 600 A <i>p. 122</i>

Applications

Main switchboard	•	•	•
Distribution panel	•	•	•
Emergency load break	•	•	•
Genset output		•	
Network coupling		•	•
Local safety load break	•	•	•
Machine control	•	•	
Photovoltaic load break			
Enclosed switches	•	•	•
Surge protection			

Functions

3/4 pole load break switch	•	•	•
6/8 pole load break switch	•		• ⁽¹⁾
3/4 pole changeover switch (I-O-II)	•		
3/4 pole changeover switch (I-I+II-II)	•		

Characteristics

Operation			
Manual (rotating)	•	•	•
Manual toggle	•		
Motorised			•
Tripping function			•
Direct operation handle			
Front	•	•	•
External operation handle			
Front	•	•	•
Right side	•		•
Indication of breaking			
Positive break indication	•	•	•
Visible contacts			•
Switch body			
Modular	•	•	•

Which operation handle?

Which type of breaking?

Photovoltaic		DC and Photovoltaic		
				
SIRCO MC PV UL 508I	SIRCO PV UL 98B	INOSYS LBS UL 98B without tripping function 100 to 600 A	INOSYS LBS UL 98B with tripping function 100 to 600 A	SIRCO MOT DC / DC ESS UL 98B
25 to 40 A <i>p. 62</i>	100 to 2000 A <i>p. 74</i>	100 to 600 A <i>p. 122</i>	100 to 600 A <i>p. 122</i>	125 to 3600 A <i>p. 110</i>

					•
					•
		•	•	•	•
	•	•	•	•	•
	•	•	•	•	
	•	•	•	•	•
	•	•			

	•	•	•	•	•
					•
				•	
	•	•	•	•	•
	•	•	•	•	
	•	•	•	•	•
			•	•	
	•		•	•	

SIRCO M and SIRCO MV

Universal load break switches

from 16 to 160 A



4 pole **SIRCO M**
direct operation

4 pole **SIRCO MV**
direct operation

The solution for

- > Main incoming load break
- > Distribution load break
- > Machine control
- > Local safety load break



Strong points

- > Total integration
- > A wide range of accessories
- > Upgradeability
- > Compliance with major certifications and approvals
- > Specific characteristics

Conformity to standards

- > IEC 60947-3



- > Other standards available



**See pages SIRCO UL and CSA range*

Approvals and certifications⁽¹⁾



(1) Product reference on request.

Function

SIRCO M and **SIRCO MV** are manually operated modifiable and modular multipolar load break switches.

They make and break under load conditions and provide safety isolation for any low voltage circuit, particularly for machine control circuits.

Advantages

Total integration

The **SIRCO M** and **SIRCO MV** fully integrate isolation, breaking and switching functions. Within a single product, **SIRCO M** offers front, right side or left side operation. Their highly functional design enables the product to be easily transformed from a load break switch to a changeover switch, offering a highly innovative modular solution for numerous applications.

A wide range of accessories

A single standard module, which can be complemented with a choice of accessories, offers a range of advantages:

- Simplicity when choosing the device.
- Flexibility to adapt to the most varied applications.
- Reduction in the cost of management and storage.

Upgradeability

Its wide range of accessories means that the **SIRCO M** can be upgraded even after it has been commissioned, enabling future requirements to be met.

Through the use of accessories, **SIRCO M** can be transformed into multipolar load break or 3/4 pole changeover switches. **SIRCO M** changeover switches provide on load changeover switching between two sources or two low voltage power circuits, as well as their safety isolation.

Compliance with major certifications and approvals

The **SIRCO M** and **SIRCO MV** range of load break switches have been designed, qualified and tested according to the criteria defined by standards IEC 60947-3, UL508 and UL98.

This process guarantees a high quality level for the product which is fully adapted to arduous operating environments.

General characteristics

- Double break per pole.
- Mounting options: DIN rail, panel or modular panel with 45 mm front cut out.
- IP20 accessories and device.
- Severe utilisation categories (AC-22 and AC-23).

Specific characteristics

SIRCO M:

- Positive break indication.
- Contact point technology.
- Product can be mounted directly on the door or panel side; see "Door mounting kit" in the accessory section.

SIRCO MV:

- Visible double breaking based on a sliding contact system (**SIRCO** type, see page "**SIRCO**").
- Positive break indication.

What you need to know

SIRCO M

- SIRCO M can be operated in 3 different ways:



sircm_028.eps

Complete switch body for toggle operation



sircm_029.psd

Direct front operation with handle



sircm_030.eps

External operation
 front, left side or right side

- The SIRCO M is a **3 pole** load break switch which is available from **16 to 125 A**. It can be combined with a switched 4th pole, an unswitched neutral or PE pole and pre-break and signalling auxiliary contacts.
- From **16 to 125 A**, through the wide range of available accessories, it is possible to convert a 3 pole load break switch into a **4, 6 or 8 pole load break switch** or a **3/4 pole changeover switch**. Through use of its door mounting kit, SIRCO M load break switches can be mounted on the panel door.



sircm_173.psd

Changeover switches I - 0 - II

SIRCO MV

- 3 operations are available:



sircm_032.psd

Direct front operation



sircm_034.eps

External **right side** operation

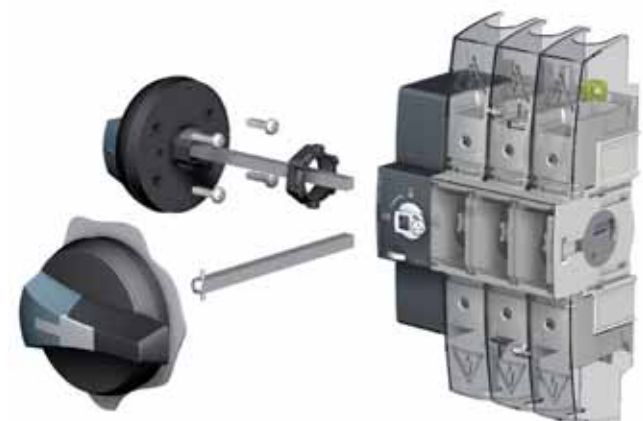

sircm_033.eps

External **front and left side** operation

- SIRCO MV can be ordered in **3 or 4 pole** from **100 to 160 A**.
- Two types of auxiliary contacts are available:
 - U-type pre-break,
 - M-type for signalisation.

SIRCO M and SIRCO MV

Universal load break switches

from 16 to 160 A

References

SIRCO M

SIRCO M - from 16 to 125 A									
Rating (A) / Frame size	No. of poles	Complete switch body toggle operation	Switch body	Direct handle	Door interlocked external front and right side handle ⁽⁴⁾	External left side handle ⁽⁶⁾	Front external handle for changeover switches ⁽⁶⁾	Shaft for external front and side handle ⁽⁶⁾	4 th pole
16 A / M1	3 P	2205 3000	2200 3000 ⁽¹⁾⁽²⁾⁽³⁾	M00 type Blue 2299 5012 Red 2299 5013	S00 type I - 0 Black IP55 1471 1111 ⁽⁴⁾ Black IP65 1473 1111 ⁽⁴⁾ Red/Yellow IP65 1474 1111 ⁽⁴⁾	S00 type I - 0 Black IP65 147A 5111 Red/Yellow IP65 147B 5111	S00 type I - 0 - II Black IP65 1473 1113 ⁽⁴⁾ I - I+II - II Black IP65 1473 1114 ⁽⁴⁾	3/4 P ≤ 125 A 6/8 P & COS ≤ 80 A S0, S00 type 150 mm 1407 0515 200 mm 1407 0520 320 mm 1407 0532	2200 1000
20 A / M1	3 P	2205 3001	2200 3001 ⁽¹⁾⁽²⁾⁽³⁾						2200 1001
25 A / M1	3 P	2205 3002	2200 3002 ⁽¹⁾⁽²⁾⁽³⁾						2200 1002
32 A / M1	3 P	2205 3003	2200 3003 ⁽¹⁾⁽²⁾⁽³⁾						2200 1003
40 A / M1	3 P	2205 3004	2200 3004 ⁽¹⁾⁽²⁾⁽³⁾						2200 1004
63 A / M2	3 P	2205 3006	2200 3006 ⁽¹⁾⁽²⁾⁽³⁾						2200 1006
80 A / M2	3 P	2205 3008	2200 3008 ⁽¹⁾⁽²⁾⁽³⁾						2200 1008
100 A / M3	3 P		2200 3010 ⁽¹⁾⁽²⁾⁽³⁾						M01 type Blue 2299 5032
125 A / M3	3 P		2200 3011 ⁽¹⁾⁽²⁾⁽³⁾	2200 1011					

(1) Front and side operation.

(2) For a 6-pole device in direct operation, order 2 x 3 pole device + conversion kit (for external operation, add the shaft + the handle).

(3) For an 8-pole device in direct operation, order 2 x 3 pole device + 2 x 4th poles + conversion kit (for external operation, add the shaft + the handle).

(4) Defeatable handle.

(5) Top and bottom.

(6) Other handles & shafts are available. Please see accessory pages.

SIRCO M

SIRCO M - from 16 to 125 A								
Rating (A) / Frame size	No. of poles	Complete switch body toggle operation	Switch body	Unswitched neutral pole	Unswitched protective earth module	Auxiliary contact	Terminal shrouds	Door mounting kit
16 A / M1	3 P	2205 3000	2200 3000 ⁽¹⁾⁽²⁾⁽³⁾	1 P 2200 5005	1 P 2200 9005	M type 1 module NO + NC 2299 0001	1 P 2294 1005 ⁽⁴⁾ 3 P 2294 3005 ⁽⁴⁾	3/4 P Complete protection IP2X 2299 3309 ⁽⁵⁾ Compact design 2299 3409 ⁽⁵⁾
20 A / M1	3 P	2205 3001	2200 3001 ⁽¹⁾⁽²⁾⁽³⁾					
25 A / M1	3 P	2205 3002	2200 3002 ⁽¹⁾⁽²⁾⁽³⁾					
32 A / M1	3 P	2205 3003	2200 3003 ⁽¹⁾⁽²⁾⁽³⁾					
40 A / M1	3 P	2205 3004	2200 3004 ⁽¹⁾⁽²⁾⁽³⁾	1 P 2200 5009	1 P 2200 9009	1 module 2 NO 2299 0011	1 P 2294 1009 ⁽⁴⁾ 3 P 2294 3009 ⁽⁴⁾	6/8 P Steel support 2299 3609 ⁽⁵⁾
63 A / M2	3 P	2205 3006	2200 3006 ⁽¹⁾⁽²⁾⁽³⁾					
80 A / M2	3 P	2205 3008	2200 3008 ⁽¹⁾⁽²⁾⁽³⁾	1 P 2200 5011	1 P 2200 9011	1 module 2 NO 2299 0011	1 P 2294 1011 ⁽⁴⁾ 3 P 2294 3016 ⁽⁴⁾	3/4 P Steel support 2299 3609 ⁽⁵⁾
100 A / M3	3 P		2200 3010 ⁽¹⁾⁽²⁾⁽³⁾					
125 A / M3	3 P		2200 3011 ⁽¹⁾⁽²⁾⁽³⁾					

(1) Front and side operation.

(2) For a 6-pole device in direct operation, order 2 x 3 pole device + conversion kit (for external operation, add the shaft + the handle).

(3) For an 8-pole device in direct operation, order 2 x 3 pole device + 2 x 4th poles + conversion kit (for external operation, add the shaft + the handle).

(4) Top and bottom.

(5) Delivered with a shaft.

SIRCO MV

SIRCO MV - from 100 to 160 A														
Rating (A)	No. of poles	Switch body	Direct handle	Door interlocked external front and right side handle ⁽⁴⁾	External left side handle ⁽⁴⁾	Shaft for external front and side handle ⁽⁴⁾	Auxiliary signal contact	Pre-break auxiliary contact	Terminal shrouds					
100 A	3 P	2200 3110	M0b type Blue 2299 5042 ⁽¹⁾	S0 type I-0 Black IP55 1491 0111 ⁽²⁾	S0 type I-0 Black IP65 149A 9111	S0 type 150 mm 1409 0615 200 mm 1409 0620 320 mm 1409 0632	M type 1 module NO + NC 2299 0001	U type 1 contact NO 3999 0701	3 P 2294 3016 ⁽³⁾ 4 P 2294 4016 ⁽³⁾					
	4 P	2200 4110												
125 A	3 P	2200 3012								M0 type Blue 2299 5022	Black IP65 1493 0111 ⁽²⁾	Red/Yellow IP65 149B 9111	1 module 2 NO 2299 0011	1 contact NC 3999 0702
	4 P	2200 4012												
160 A	3 P	2200 3016		Red/Yellow IP65 1494 0111 ⁽²⁾										
	4 P	2200 4016												

(1) Standard.

(2) Defeatable handle.

(3) Top and bottom.

(4) Other handles & shafts are available. Please see accessory pages.

SIRCO M and SIRCO MV

Universal load break switches

from 16 to 160 A

Accessories

Direct operation handle

For SIRCO M

Rating (A) / Frame size	Handle colour	Handle type	Reference
16 ... 80 / M1 ... M2	Blue	M00	2299 5012 ⁽¹⁾
16 ... 80 / M1 ... M2	Red	M00	2299 5013
100 ... 125 / M3	Blue	M01	2299 5032 ⁽¹⁾

(1) Standard.

For SIRCO MV

Rating (A)	Handle colour	Handle type	Reference
100 ... 160	Blue	M0b	2299 5042 ⁽¹⁾
100 ... 160	Blue	M0	2299 5022

(1) Standard.

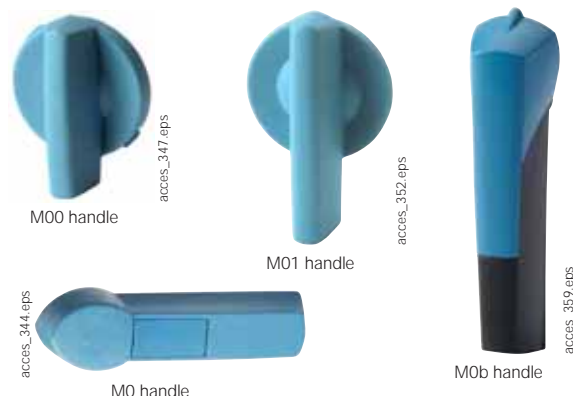

External handle operation - SIRCO M

S000 type handle

Rating (A) / Frame size	Type	No. of poles	Operation	Handle colour	External IP	Defeatable handle	Reference
16 ... 80 / M1... M2	Switch	3/4 P	Front and side operation	Black	IP65	no	1463 5111
	Switch	3/4 P	Front and side operation	Red/Yellow	IP65	no	1464 5111
16 ... 80 / M1... M2	Changeover switches I - 0 - II	3/4 P	Front	Black	IP65	no	1463 5113
	Changeover switches I - I+II - II	3/4 P	Front	Black	IP65	no	1463 5114



S000 handle

S00 type handle

Rating (A) / Frame size	Type	No. of poles	Operation	Handle colour	External IP	Defeatable handle	Reference
16 ... 80 / M1... M2	Switch	3/4 P ⁽¹⁾	Front and side operation	Black	IP55	yes	1471 1111
	Switch	3/4 P ⁽¹⁾	Front and side operation	Black	IP65	yes	1473 1111
	Switch	3/4 P ⁽¹⁾	Front and side operation	Red/Yellow	IP65	yes	1474 1111
	Switch	3/4 P	Left side	Black	IP65	no	147A 5111
	Switch	3/4 P	Left side	Red/Yellow	IP65	no	147B 5111
100 ... 125 / M3	Switch	6/8 P	Front	Black	IP55	yes	1471 0111
	Switch	6/8 P	Front	Black	IP65	yes	1473 0111
	Switch	6/8 P	Front	Red/Yellow	IP65	yes	1474 0111
16 ... 80 / M1... M2	Changeover switches I - 0 - II	3/4 P	Front	Black	IP65	yes	1473 1113
	Changeover switches I - I+II - II	3/4 P	Front	Black	IP65	yes	1473 1114
100 ... 125 / M3	Changeover switches I - 0 - II	3/4 P	Front	Black	IP65	yes	1473 0113
	Changeover switches I - I+II - II	3/4 P	Front	Black	IP65	yes	1473 0114



S00 handle

(1) Can also be used with 6 and 8 poles with front operation.

External operation handle - SIRCO M (continued)

S0 type handle

Rating (A) / Frame size	Type	No. of poles	Operation	Handle colour	External IP	Defeatable handle	Reference
100 ... 125 / M3	Switch	3/4 P	Front and side operation	Black	IP55	yes	1481 1111
	Switch	3/4 P	Front and side operation	Black	IP65	yes	1483 1111
	Switch	3/4 P	Front and side operation	Red/Yellow	IP65	yes	1484 1111
	Switch	3/4 P	Left side	Black	IP65	no	148A 5111
	Switch	3/4 P	Left side	Red/Yellow	IP65	no	148B 5111



S0 handle

access_343.eps

S01 type handle

Rating (A) / Frame size	Type	No. of poles	Operation	Handle colour	External IP	Defeatable handle	Reference
16 ... 125 / M1 ... M3	Switch	3/4 P ⁽²⁾	Front and side operation	Black	IP65	yes	1403 2111
	Switch	3/4 P ⁽²⁾	Front and side operation	Red/Yellow	IP65	yes	1404 2111
16 ... 80 / M1 ... M2	Changeover switches I - 0 - II	3/4 P	Front	Black	IP65	yes	1403 2113
	Changeover switches I - 0 - II	3/4 P	Front	Black	IP65	yes	1403 2813 ⁽¹⁾
	Changeover switches I - I+II - II	3/4 P	Front	Black	IP65	yes	1403 2114
	Changeover switches I - I+II - II	3/4 P	Front	Black	IP65	yes	1403 2814 ⁽¹⁾



S01 handle

access_304.eps

(1) Padlockable in 3 positions.

(2) Can also be used with 6 and 8 pole devices from 16 to 40 A.

External operation handle - SIRCO MV

S0 type handle

Rating (A)	Type	No. of poles	Operation	Handle colour	External IP	Defeatable handle	Reference
100 ... 160	Switch	3/4 P	Front and side operation	Black	IP55	yes	1491 0111
100 ... 160	Switch	3/4 P	Front and side operation	Black	IP65	yes	1493 0111
100 ... 160	Switch	3/4 P	Front and side operation	Red/Yellow	IP65	yes	1494 0111
100 ... 160	Switch	3/4 P	Left side	Black	IP65	no	149A 9111
100 ... 160	Switch	3/4 P	Left side	Red/Yellow	IP65	no	149B 9111



S0 handle

access_343.eps

S1 type handle

Rating (A)	Type	No. of poles	Operation	Handle colour	External IP	Defeatable handle	Reference
100 ... 160	Switch	3/4 P	Front	Black	IP55	yes	1411 2111
100 ... 160	Switch	3/4 P	Front	Black	IP65	yes	1413 2111
100 ... 160	Switch	3/4 P	Front	Red/Yellow	IP65	yes	1414 2111
100 ... 160	Switch	3/4 P	Right side	Black	IP55	no	1415 2111
100 ... 160	Switch	3/4 P	Right side	Black	IP65	no	1417 2111
100 ... 160	Switch	3/4 P	Right side	Red/Yellow	IP65	no	1418 2111
100 ... 160	Switch	3/4 P	Left side	Black	IP65	no	141A 2111
100 ... 160	Switch	3/4 P	Left side	Red/Yellow	IP65	no	141B 2111



S1 Handle

access_284.eps

SIRCO M and SIRCO MV

Universal load break switches

from 16 to 160 A

Accessories (continued)

Shaft for external handle

SIRCO M 3/4 P

Rating (A) / Frame size	Handle type	Type	Length (mm)	Reference
16 ... 125 / M1... M3	S000 / S00 / S0	Switch	150 mm	1407 0515
	S000 / S00 / S0	Switch	200 mm	1407 0520
	S000 / S00 / S0	Switch	320 mm	1407 0532
	S01	Switch	200 mm	1404 0520
	S01	Switch	320 mm	1404 0532
	S01	Switch	400 mm	1404 0540



access_314.eps

SIRCO M 6/8 pole load break switch and 3/4 pole changeover switch

Rating (A)	Handle type	Type	Length (mm)	Reference
16 ... 80 / M1...M2	S000, S00	6/8 P and changeover switch	150 mm	1407 0515
	S000, S00	6/8 P and changeover switch	200 mm	1407 0520
	S000, S00	6/8 P and changeover switch	320 mm	1407 0532
100 ... 125 / M3	S00	6/8 P and changeover switch	150 mm	1409 0615
	S00	6/8 P and changeover switch	200 mm	1409 0620
	S00	6/8 P and changeover switch	320 mm	1409 0632
16 ... 40 / M1	S01	6/8 P	200 mm	1404 0520
	S01	6/8 P	320 mm	1404 0532
	S01	6/8 P	400 mm	1404 0540
16 ... 80 / M1 ... M2	S01	Changeover switch	200 mm	1404 0520
	S01	Changeover switch	320 mm	1404 0532
	S01	Changeover switch	400 mm	1404 0540

Use

Shaft lengths:

- 150 mm,
- 200 mm,
- 320 mm,
- 400 mm.

For 3/4 pole switches, shaft extensions are for external front and side operation.

For 6/8 pole switches and changeover switches, shaft extensions are for front operation only.

For SIRCO MV

Rating (A)	Handle type	Type	Length (mm)	Reference
100 ... 160	S0	Switch	150 mm	1409 0615
100 ... 160	S0	Switch	200 mm	1409 0620
100 ... 160	S0	Switch	320 mm	1409 0632
100 ... 160	S1	Switch	200 mm	1401 0620
100 ... 160	S1	Switch	320 mm	1401 0632
100 ... 160	S1	Switch	400 mm	1401 0640

Shaft guide for external operation

Use

To guide the shaft extension into the external handle.

This accessory enables the handle to engage the extension shaft with a misalignment of up to 15 mm. Required for a shaft length over 320 mm.

Description	Handle type	To be ordered in multiples of	Reference
Shaft guide	S00 and S0 / S000	10 pieces	1419 0000
Shaft guide	S01 and S1	1 piece	1429 0000



access_2160.eps

Additional pole for SIRCO M

Switched fourth pole module

Rating (A) / Frame size	No. of poles	Type	Reference
16 / M1	1 P	switched	2200 1000
20 / M1	1 P	switched	2200 1001
25 / M1	1 P	switched	2200 1002
32 / M1	1 P	switched	2200 1003
40 / M1	1 P	switched	2200 1004
63 / M2	1 P	switched	2200 1006
80 / M2	1 P	switched	2200 1008
100 / M3	1 P	switched	2200 1010
125 / M3	1 P	switched	2200 1011

Use

Adds one or two poles and transforms:

- a 3 pole SIRCO M into a 4 pole load break switch,
- a 6 pole SIRCO M into a 8 pole load break switch,
- a 3 pole SIRCO M into a 4 pole changeover switch.



4th pole

Protective earth module

Neutral pole

Neutral pole

Rating (A) / Frame size	No. of poles	Type	Reference
16 ... 40 / M1	1 P	unswitched	2200 5005
63 ... 80 / M2	1 P	unswitched	2200 5009
100 ... 125 / M3	1 P	unswitched	2200 5011

Use

Transforms the 3-pole switch into a 3-pole + solid neutral.

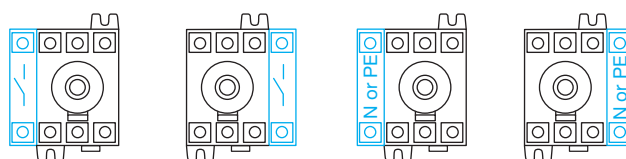

Protective earth module

Rating (A) / Frame size	No. of poles	Type	Reference
16 ... 40 / M1	1 P	unswitched	2200 9005
63 ... 80 / M2	1 P	unswitched	2200 9009
100 ... 125 / M3	1 P	unswitched	2200 9011

Use

Adds 1 protective earth module pole to the switch-disconnector.

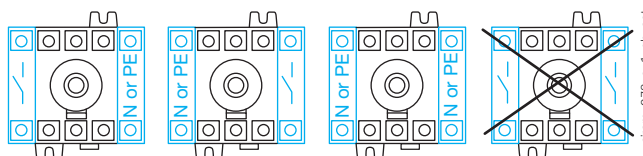

Additional pole configuration

Terminal shrouds

Use

Top and bottom protection against direct contact with the terminals or connection parts.

Available in 1 or 3 pole versions for SIRCO M and in 3 or 4 pole versions for SIRCO MV.

An opening on each terminal cover makes it possible to insert a temperature measurement probe.

For SIRCO M

Rating (A) / Frame size	No. of poles	Position	Reference
16 ... 40 / M1	1 P	top and bottom	2294 1005
16 ... 40 / M1	3 P	top and bottom	2294 3005
63 ... 80 / M2	1 P	top and bottom	2294 1009
63 ... 80 / M1	3 P	top and bottom	2294 3009
100 ... 125 / M3	1 P	top and bottom	2294 1011
100 ... 125 / M3	3 P	top and bottom	2294 3016

For SIRCO MV

Rating (A)	No. of poles	Position	Reference
100 ... 160	3 P	top and bottom	2294 3016
100 ... 160	4 P	top and bottom	2294 4016

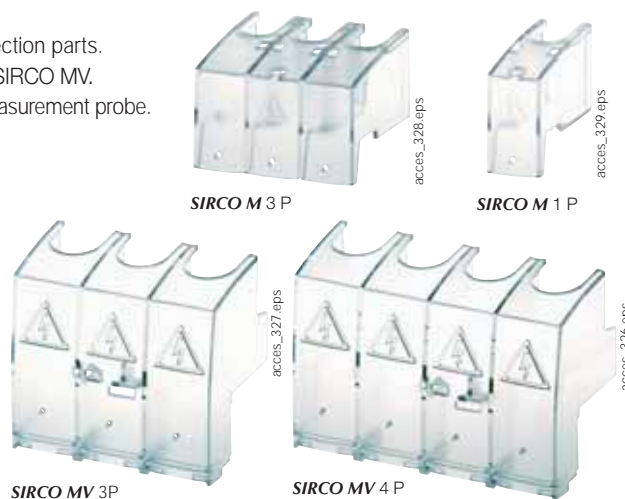

SIRCO M and SIRCO MV

Universal load break switches

from 16 to 160 A

Accessories (continued)

M type auxiliary contacts

Use

Pre-break and signalisation of positions 0 and I by NO+NC or 2 NO auxiliary contacts.

They allow to anticipate the switching of the main poles. They can be mounted on the left or on the right side of the device.

Max 4 auxiliary contacts (2 modules).

Pre-break is not guaranteed on the SIRCO MV.

Characteristics

NO+NC auxiliary contacts: IP2 with front operation.

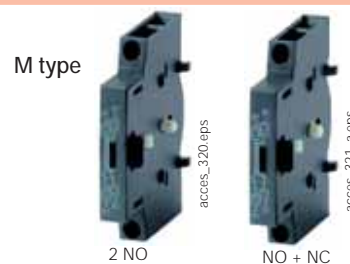

For SIRCO M

Rating (A) / Frame size	Number of AC	Type of AC	Reference
16 ... 125 / M1...M3	1 AC	NO + NC	2299 0001
	1 AC	2 NO	2299 0011

For SIRCO MV

Rating (A)	Number of AC	Type of AC	Reference
100 ... 160	1 AC	NO + NC	2299 0001
100 ... 160	1 AC	2 NO	2299 0011

Characteristics

Contact type	Nominal current (A)	Operating current I _e (A) 230 VAC	
		AC-13	AC-15
NO + NC	10	10	6

Auxiliary contact configurations for SIRCO MV

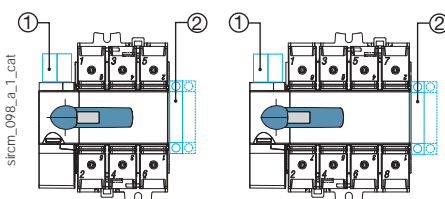

1. Maximum 2 "U" type auxiliary contacts.
2. Maximum 2 "M" type auxiliary contact modules.

For SIRCO MV

Rating (A)	Number of AC	Type of AC	Reference
100 ... 160	1 AC	NO	3999 0701
100 ... 160	1 AC	NC	3999 0702

Characteristics

Contact type	Nominal current (A)	Operating current I _e (A)			
		250 VAC AC-15	400 VAC AC-15	24 VDC DC-13	48 VDC DC-13
NC	10	3	1.8	2.8	1.4
NO	10	3	1.8	2.8	1.4

Auxiliary contacts configurations for SIRCO M

Max: 2 blocks / Max: 2 AC



Pre-break



No Pre-break

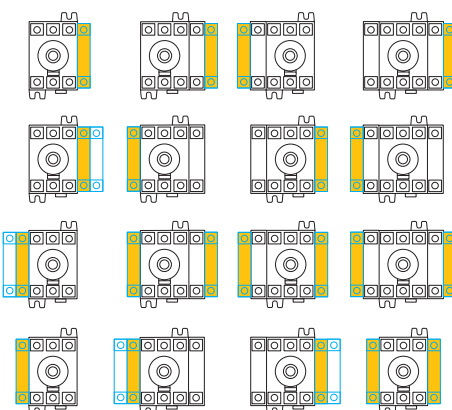

sircm_188_a_1_x_cat

U type



Use

Pre-break and signalisation by NO or NC auxiliary contact can be mounted on the device. Maximum 2 auxiliary contacts. Only available for SIRCO MV switches.

Conversion kit

Use

It must be ordered together with the handle for external control.

This accessory enables the assembly of two 3 pole switches (+ additional pole) in order to create :

- a 6 or 8 pole SIRCO M load break switch,
- a 3 or 4 pole SIRCO M changeover switch.

Load break switches 6/8 P

Rating (A) / Frame size	Type	Reference
16 ... 80 / M1 ... M2	6/8 P switch	2269 6009
100 ... 125 / M3	6/8 P switch	2269 6011

Changeover switches I - 0 - II

Rating (A) / Frame size	Type	Reference
16 ... 80 / M1 ... M2	Changeover switches I - 0 - II	2209 6009
100 ... 125 / M3	Changeover switches I - 0 - II	2209 6011

SIRCO M changeover switches provide on load changeover switching between two sources or two low voltage power circuits, as well as their safety isolation (I - 0 - II); transfer without interruption of the supply is also possible (I - I+II - II).

Changeover switches I - I+II - II

Rating (A) / Frame size	Type	Reference
16 ... 80 / M1 ... M2	Changeover switches I - I+II - II	2299 6009
100 ... 125 / M3	Changeover switches I - I+II - II	2299 6011

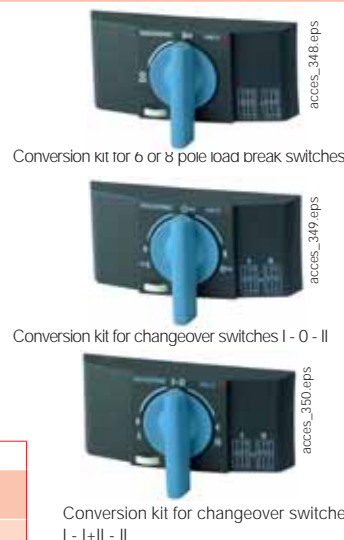

Door mounting kit⁽¹⁾

Use

This kit enables a direct mounting of the switch on the door panel, on the right or left side of the panel.
 The connection clamps of the switch are always accessible.

The external handle is quick and easy to install with the supplied internal locking nut mounted on the inside of the enclosure.
 3 kits are available:
 - one for complete protection IP2X
 - one with compact design
 - one in steel for 6/8 P and 100/125 A.

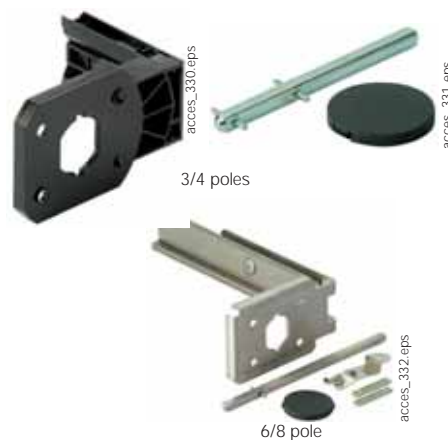

For SIRCO M

(1) Kit compatible with S00 type handle only

Rating (A) / Frame size	No. of poles	Description	Reference
16 ... 80 / M1 ... M2	3/4 P	Complete protection IP2X	2299 3309
	3/4 P	Compact version	2299 3409
	6/8 P	Metallic support	2299 3609
100 ... 125	3/4 P	Metallic support	2299 3609

Cap for side operation mounting

Use

This accessory enables the front face of the SIRCO M to be capped when the switch is side operated. 20 pieces supplied per pack.

This piece snaps into place directly on the front face of the switch.



For SIRCO M

Rating (A) / Frame size	Pack	Reference
16 ... 125 / M1 ... M3	20 pieces	2299 9409

6/8 pole joining accessory

Use

This accessory enables two 3/4 pole switches to be coupled in order to provide a 6 or 8 pole switch for external side operation. 40 pieces supplied per pack.

For multi-pole switches, please consult us.

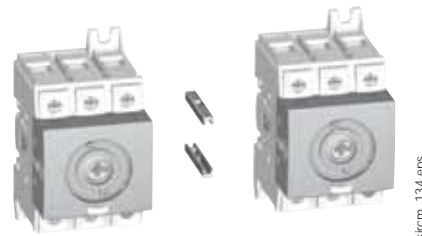

For SIRCO M

Rating (A) / Frame size	Pack	Reference
16 ... 80 / M1 ... M2	40 pieces	2299 9909

DIN rail locking clip

Use

This locking clip prevents the SIRCO MV from sliding when DIN rail mounted.

For SIRCO MV

Rating (A)	Type	Reference
100 ... 160	Locking clip M4	5000 0041
100 ... 160	Locking clip M5	5000 0051



Voltage sensing and power supply tap

Use

It allows connection of 2x ≤1.5 mm² voltage sensing or power cables.

This single-pole voltage sensing tap allows the connection of 2 x ≤1.5 mm² voltage sensing or power cables to any SIRCO MV power terminal without reducing its connection capacity.

For SIRCO MV

Rating (A)	Pack	Reference
100 ... 160	2 pieces	1399 4006



Characteristics

Characteristics according to IEC 60947-3

Thermal current I_{th} (40 °C)	SIRCO M - from 16 to 125 A								
	16 A	20 A	25 A	32 A	40 A	63 A	80 A	100 A	125 A
Frame size	M1	M1	M1	M1	M1	M2	M2	M3	M3
Rated insulation voltage U_i (V)	800	800	800	800	800	800	800	800	800
Rated impulse withstand voltage U_{imp} (kV)	8	8	8	8	8	8	8	8	8

Rated operational currents I_e (A)

Rated voltage	Utilisation category	A/B ⁽¹⁾	A/B ⁽¹⁾	A/B ⁽¹⁾	A/B ⁽¹⁾	A/B ⁽¹⁾	A/B ⁽¹⁾	A/B ⁽¹⁾	A/B ⁽¹⁾	A/B ⁽¹⁾
415 VAC	AC-20 A / AC-20 B	16/16	20/20	25/25	32/32	40/40	63/63	80/80	100/100	125/125
415 VAC	AC-21 A / AC-21 B	16/16	20/20	25/25	32/32	40/40	63/63	80/80	100/100	125/125
415 VAC	AC-22 A / AC-22 B	16/16	20/20	25/25	32/32	40/40	63/63	80/80	100/100	125/125
415 VAC	AC-23 A / AC-23 B	16/16	20/20	25/25	32/32	40/40	63/63	80/80	100/100	125/125
500 VAC	AC-20 A / AC-20 B	16/16	20/20	25/25	32/32	40/40	63/63	80/80	100/100	125/125
500 VAC	AC-21 A / AC-21 B	16/16	20/20	25/25	32/32	40/40	63/63	80/80	100/100	125/125
500 VAC	AC-22 A / AC-22 B	16/16	20/20	25/25	32/32	40/40	63/63	80/80	100/100	125/125
500 VAC	AC-23 A / AC-23 B	16/16	20/20	25/25	25/25	25/25	63/63	63/63	80/80	100/100
690 VAC	AC-20 A / AC-20 B	16/16	20/20	25/25	32/32	40/40	63/63	80/80	100/100	125/125
690 VAC	AC-21 A / AC-21 B	16/16	20/20	25/25	32/32	40/40	63/63	80/80	100/100	125/125
690 VAC	AC-22 A / AC-22 B	16/16	20/20	25/25	32/32	32/40	40/63	63/80	80/100	100/125
690 VAC	AC-23 A / AC-23 B	16/16	20/20	25/25	25/25	25/25	40/40	40/40	63/63	63/63
110 VDC	DC-20 A / DC-20 B	16/16	20/20	25/25	32/32	40/40	63/63	80/80	100/100	125/125
110 VDC	DC-21 A / DC-21 B	16/16 ⁽²⁾	20/20 ⁽²⁾	25/25 ⁽²⁾	32/32 ⁽²⁾	40/40 ⁽²⁾	63/63 ⁽²⁾	80/80 ⁽²⁾	100/100 ⁽²⁾	125/125 ⁽²⁾
250 VDC	DC-20 A / DC-20 B	16/16	20/20	25/25	32/32	40/40	63/63	80/80	100/100	125/125
250 VDC	DC-21 A / DC-21 B	16/16 ⁽³⁾	20/20 ⁽³⁾	25/25 ⁽³⁾	32/32 ⁽³⁾	40/40 ⁽³⁾	63/63 ⁽³⁾	80/80 ⁽³⁾	100/100 ⁽³⁾	125/125 ⁽³⁾
400 VDC	DC-20 A / DC-20 B	16/16	20/20	25/25	32/32	40/40	63/63	80/80	100/100	125/125
400 VDC	DC-21 A / DC-21 B	16/16 ⁽⁴⁾	20/20 ⁽⁴⁾	25/25 ⁽⁴⁾	25/25 ⁽⁴⁾	25/25 ⁽⁴⁾	40/40 ⁽⁴⁾	40/40 ⁽⁴⁾	63/63 ⁽⁴⁾	63/63 ⁽⁴⁾

Operational power in AC-23 (kW)

400 VAC without pre-break AC (kW) ⁽⁵⁾	7.5	9	11	15	18.5	30	37	45	55
500 VAC without pre-break AC (kW) ⁽⁵⁾	7.5	9	11	15	18.5	30	37	45	55
690 VAC without pre-break AC (kW) ⁽⁵⁾	7.5	11	15	15	15	30	37	45	55

Fuse protected short-circuit withstand (kA rms prospective)⁽⁶⁾

Prospective short-circuit current (kA rms)	50	50	50	50	50	50	50	25	25
Associated fuse rating (A)	16	20	25	32	40	63	80	100	125

Circuit breaker protected short-circuit withstand with any circuit breaker that ensures tripping in less than 0.3s

Rated short-time withstand current 0.3s. I_{cw} (kA rms)	2.5	2.5	2.5	2.5	2.5	3	3	5	5
--	-----	-----	-----	-----	-----	---	---	---	---

Short-circuit capacity (without protection)

Rated short-time withstand current 1s. I_{cw} (kA rms)	1.26	1.26	1.26	1.26	1.26	1.5	1.5	2.75	2.75
Rated peak withstand current (kA peak) ⁽⁶⁾	6	6	6	6	6	9	9	12	12

Connection

Minimum Cu cable cross-section (mm ²)	1.5	1.5	1.5	1.5	1.5	2.5	2.5	10	10
Maximum Cu cable cross-section (mm ²)	16	16	16	16	16	35	35	70	70
Tightening torque min/max (Nm)	2 / 2.2	2 / 2.2	2 / 2.2	2 / 2.2	2 / 2.2	3.5 / 3.85	3.5 / 3.85	4/4.4	4/4.4

Mechanical characteristics

Durability (number of operating cycles)	100 000	100 000	100 000	100 000	100 000	100 000	100 000	100 000	100 000
Operating effort - 3 pole device (Nm)	1	1	1	1	1	1.4	1.4	1.6	1.6
Operating effort - 4 pole device (Nm)	1.2	1.2	1.2	1.2	1.2	1.6	1.6	2	2
Weight of a 3 pole device (kg)	0.18	0.18	0.18	0.18	0.18	0.27	0.27	0.55	0.55
Weight of a 4 pole device (kg)	0.23	0.23	0.23	0.23	0.23	0.33	0.33	0.72	0.72
Weight of a 6 pole device (kg)	0.40	0.40	0.40	0.40	0.40	0.59	0.59	1.30	1.30
Weight of a 8 pole device (kg)	0.50	0.50	0.50	0.50	0.50	0.69	0.69	1.65	1.65
Weight of a 3 pole device (kg)	0.40	0.40	0.40	0.40	0.40	0.59	0.59	1.30	1.30
Weight of a 4 pole device (kg)	0.50	0.50	0.50	0.50	0.50	0.69	0.69	1.65	1.65

(1) Category with index A = frequent operation -
Category with index B = infrequent operation.

(2) One pole per polarity.

(3) 3-pole device with 2 poles in series for the "+" and 1 pole for the "-".

(4) 4-pole device with 2 poles in series per polarity.

(5) The power value is given for information only, the current values vary from one manufacturer to another.

(6) For a rated operational voltage $U_e = 415$ VAC.

Characteristics

Characteristics according to IEC 60947-3

		SIRCO MV - from 100 to 160 A		
Thermal current I_{th} (40 °C)		100 A	125 A	160 A
Rated insulation voltage U_i (V)		800	800	800
Rated impulse withstand voltage U_{imp} (kV)		8	8	8
Rated operational currents I_e (A)				
Rated voltage	Utilisation category	A/B ⁽¹⁾	A/B ⁽¹⁾	A/B ⁽¹⁾
415 VAC	AC-20 A / AC-20 B	100/100	125/125	160/160
415 VAC	AC-21 A / AC-21 B	100/100	125/125	160/160
415 VAC	AC-22 A / AC-22 B	100/100	125/125	160/160
415 VAC	AC-23 A / AC-23 B	100/100	125/125	125/160
500 VAC	AC-20 A / AC-20 B	100/100	125/125	160/160
500 VAC	AC-21 A / AC-21 B	100/100	125/125	160/160
500 VAC	AC-22 A / AC-22 B	100/100	125/125	125/160
500 VAC	AC-23 A / AC-23 B	80/80	100/100	100/100
690 VAC	AC-20 A / AC-20 B	100/100	125/125	160/160
690 VAC	AC-21 A / AC-21 B	100/100	125/125	160/160
690 VAC	AC-22 A / AC-22 B	63/80	80/100	100/125
690 VAC	AC-23 A / AC-23 B	63/63	80/80	80/80
110 VDC	DC-20 A / DC-20 B	100/100	125/125	160/160
110 VDC	DC-21 A / DC-21 B	100/100 ⁽²⁾	125/125 ⁽²⁾	160/160 ⁽²⁾
250 VDC	DC-20 A / DC-20 B	100/100	125/125	160/160
250 VDC	DC-21 A / DC-21 B	100/100 ⁽³⁾	125/125 ⁽³⁾	160/160 ⁽³⁾
400 VDC	DC-20 A / DC-20 B	100/100	125/125	160/160
400 VDC	DC-21 A / DC-21 B	100/100 ⁽⁴⁾	125/125 ⁽⁴⁾	160/160 ⁽⁴⁾
Operational power in AC-23 (kW)				
400 VAC without pre-break AC (kW) ⁽⁵⁾		45	55	75
500 VAC without pre-break AC (kW) ⁽⁵⁾		45	55	75
690 VAC without pre-break AC (kW) ⁽⁵⁾		45	75	75
Fuse protected short-circuit withstand (kA rms prospective) ⁽⁶⁾				
Prospective short-circuit current (kA rms)		100	65	50
Associated fuse rating (A)		100	125	160
Circuit breaker protected short-circuit withstand with any circuit breaker that ensures tripping in less than 0.3s				
Rated short-time withstand current 0.3s. I_{cw} (kA rms)		7	7	7
Short-circuit capacity (without protection)				
Rated short-time withstand current 1s. I_{cw} (kA rms)		4	4	4
Rated peak withstand current (kA peak) ⁽⁶⁾		12	12	12
Connection				
Minimum Cu cable cross-section (mm ²)		10	10	10
Maximum Cu cable cross-section (mm ²)		70	70	70
Tightening torque min/max (Nm)		4 / 4.4	4 / 4.4	4 / 4.4
Mechanical characteristics				
Durability (number of operating cycles)		50 000	50 000	50 000
Operating effort - 3 pole device (Nm)		4	4	4
Operating effort - 4 pole device (Nm)		4.2	4.2	4.2
Weight of a 3 pole device (kg)		0.68	0.68	0.68
Weight of a 4 pole device (kg)		0.85	0.85	0.85

(1) Category with index A = frequent operation - Category with index B = infrequent operation.

(2) One pole per polarity.

(3) 2 poles in series for the "+" and 1 pole for the "-".

(4) 2 poles in series per polarity.

(5) The power value is given for information only, the current values vary from one manufacturer to another.

(6) For a rated operational voltage $U_e = 415$ VAC.

SIRCO M and SIRCO MV

Universal load break switches

from 16 to 160 A

Dimensions

SIRCO M1 and M2 16 to 80 A

Toggle operation

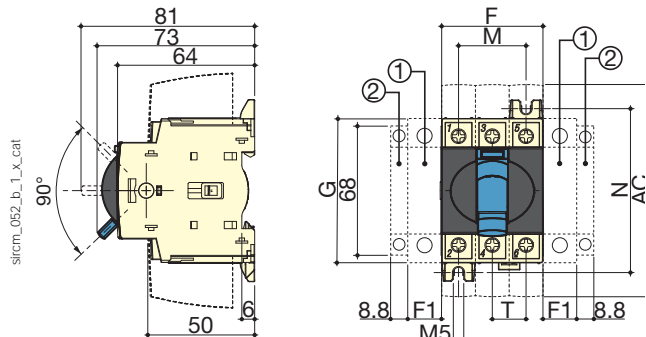

1. Location for: 1 switched fourth pole module (1 per device max.) or 1 unswitched neutral pole or 1 protective earth module or 1 auxiliary contact.

2. Position for 1 auxiliary contact module only.

Note: max 2 additional blocks.

Direct operation with handle

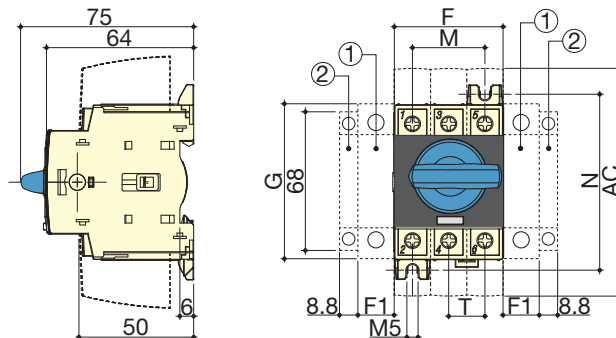

1. Location for: 1 switched fourth pole module (1 per device max.) or 1 unswitched neutral pole or 1 protective earth module or 1 auxiliary contact.

2. Position for 1 auxiliary contact module only.

Note: max 2 additional blocks.

External front operation

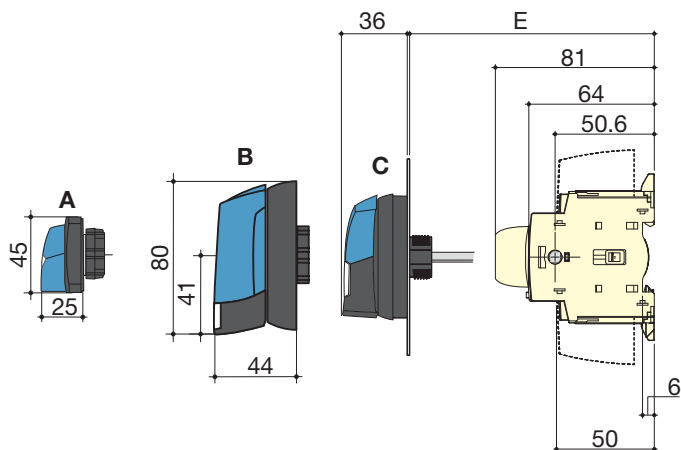

1. Location for: 1 switched fourth pole module (1 per device max.) or 1 unswitched neutral pole or 1 protective earth module or 1 auxiliary contact.

2. Position for 1 auxiliary contact module only.

Note: max 2 additional blocks.

External side operation

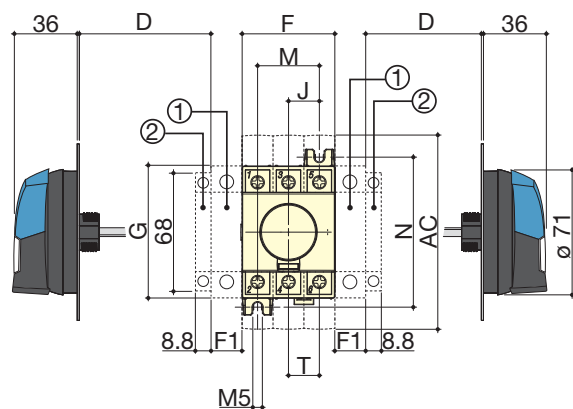

A. S000 Handle

B. S01 Handle

C. S00 Handle.

Rating (A) / Frame size	Overall dimensions				Terminal shrouds		Switch body				Switch mounting		Connection
	D min	D max	E min	E max	AC	F	F1	G	J	M	N	T	
16 ... 40 / M1	30	235	100	372	110	45	15	68	15	30	75	15	
63 ... 80 / M2	30	235	100	372	110	52.5	17.5	76	17.5	35	85	17.5	

SIRCO M1 and M2 16 to 80 A (continued)

Direct front operation for
 6/8-pole load break switches or 3/4-pole changeover switches

External front operation for 6/8-pole load break switches or
 3/4-pole changeover switches

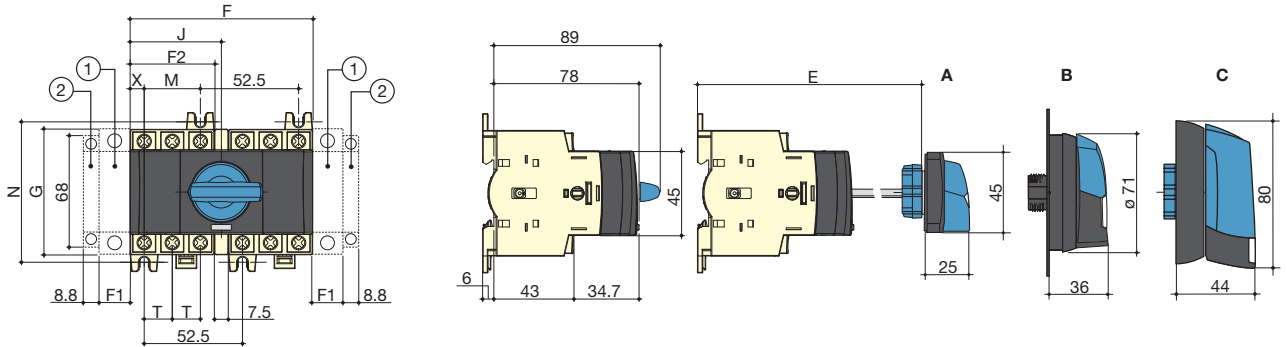

1. Location for: 1 switched fourth pole module (1 per device max.) or 1 unswitched neutral pole or 1 protective earth module or 1 auxiliary contact.
 2. Position for 1 auxiliary contact module only.

- A. S000 handle
 B. S00 handle
 C. S01 handle

Note: max 2 additional blocks.

Rating (A) / Frame size	Overall dimensions		Switch body					Switch mounting		Connection	
	E min	E max	F	F1	F2	G	J	M	N	T	X
16 ... 40 / M1	105	372	97.5	15	45	68	48.75	30	75	15	7.5
63 ... 80 / M2	105	372	105	17.5	52.5	76	52.5	35	85	17.5	8.75

SIRCO M3 100 to 125 A

Direct operation with handle

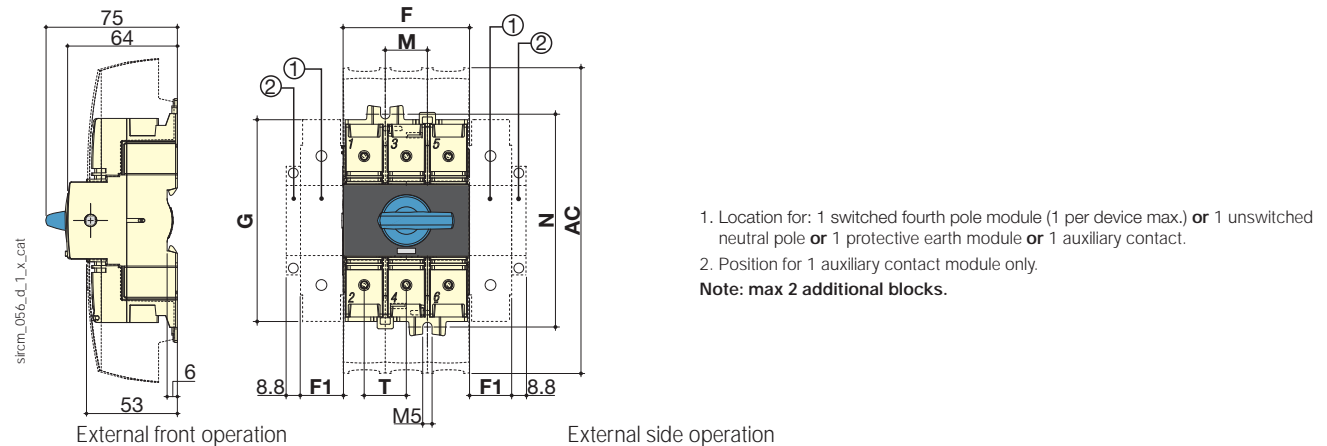

1. Location for: 1 switched fourth pole module (1 per device max.) or 1 unswitched neutral pole or 1 protective earth module or 1 auxiliary contact.
 2. Position for 1 auxiliary contact module only.

Note: max 2 additional blocks.

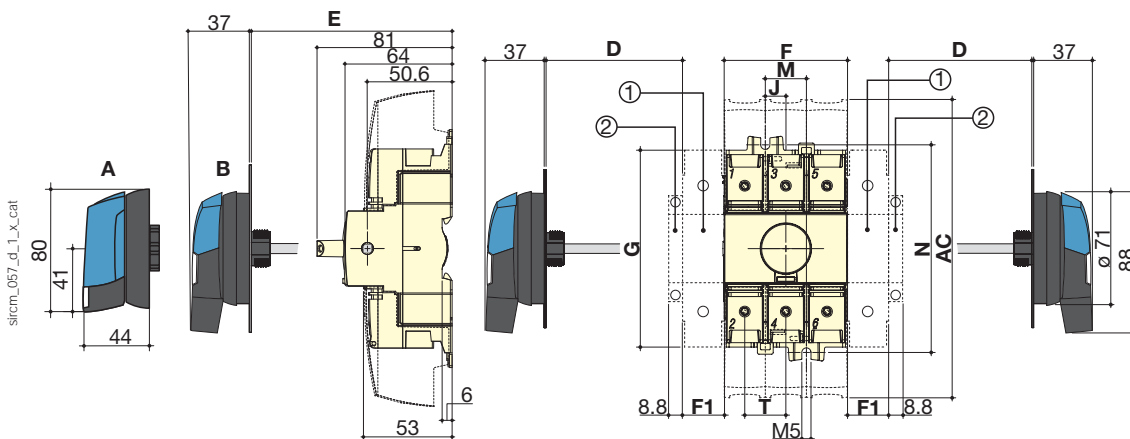

1. Location for: 1 switched fourth pole module (1 per device max.) or 1 unswitched neutral pole or 1 protective earth module or 1 auxiliary contact.
 2. Position for 1 auxiliary contact module only.

Note: max 2 additional blocks.

- A. S01 handle
 B. S00 handle

Rating (A) / Frame size	Overall dimensions				Terminal shrouds	Switch body				Switch mounting		Connection
	D min	D max	E min	E max	AC	F	F1	G	J	M	N	T
100 ... 125 / M3	30	201	100	372	189	78	26	124.6	13	26	131.4	26

SIRCO M and SIRCO MV

Universal load break switches

from 16 to 160 A

Dimensions (continued)

SIRCO M3 6/8 P and changeover switch M3 100 to 125 A

Direct front operation for 3/4 pole changeover switches

External front operation for 3/4 pole changeover switches

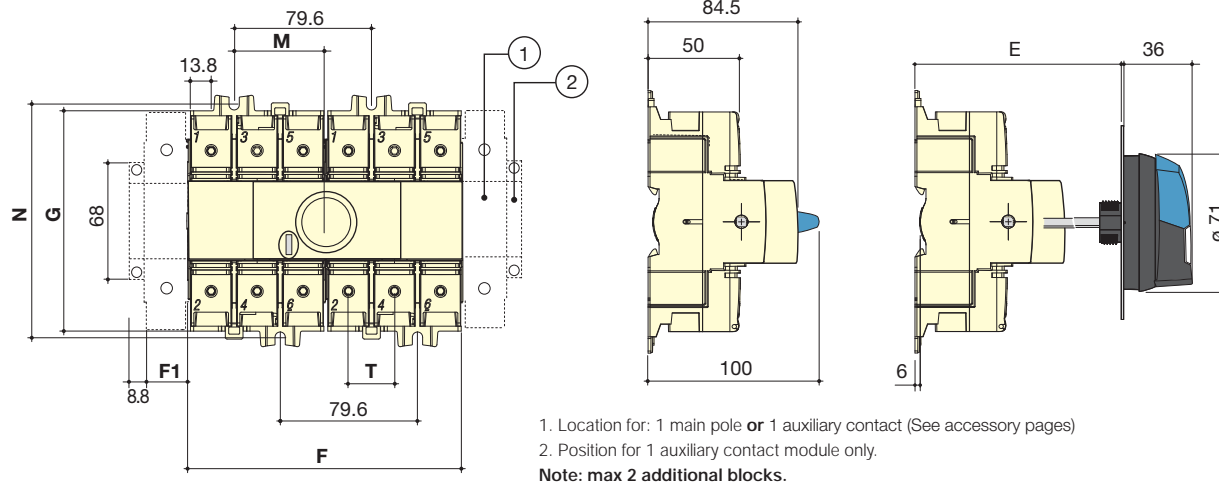

sircm_183_e_1_x_cat

Rating (A) / Frame size	Overall dimensions		Switch body			Switch mounting		Connection
	E min	E max	F	F1	G	M	N	
100 ... 125 / M3	105	372	159	26	124.5	52.8	131.5	26

SIRCO MV 100 to 160 A

Direct front operation

External front operation

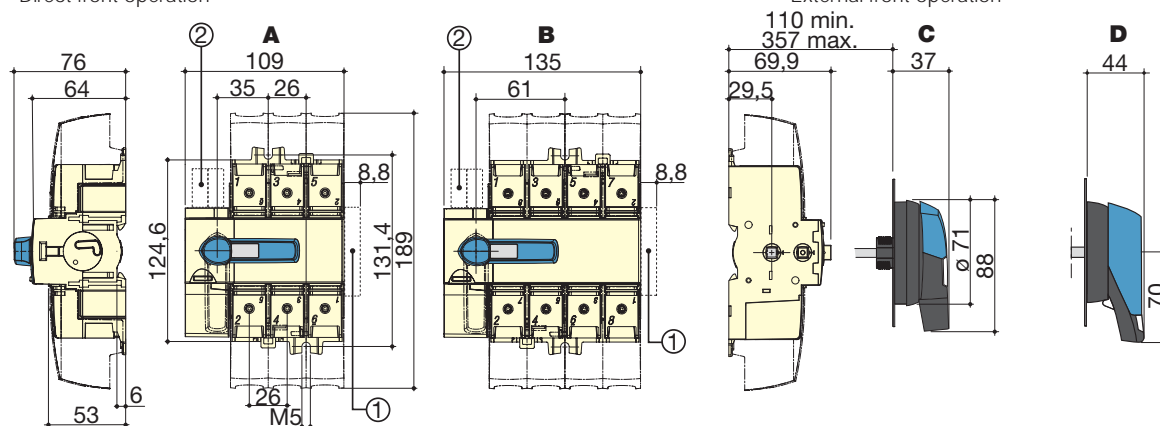

A. 3 poles
 B. 4 poles

C. S0 type handle
 D. S1 type handle

1. Maximum 4 "M" type auxiliary contacts
 2. Maximum 2 "U" type auxiliary contacts

sircm_058_c_1_x_cat

External side operation

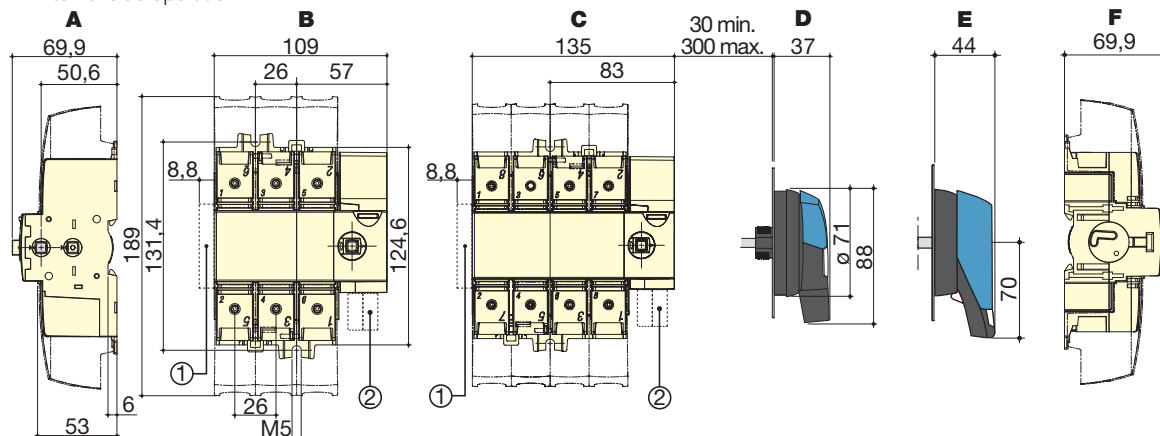

A. Right side operation
 B. 3 poles
 C. 4 poles

D. S0 type handle
 E. S1 type handle
 F. Left side operation

1. Maximum 4 "M" type auxiliary contacts
 2. Maximum 2 "U" type auxiliary contacts

sircm_052_d_1_x_cat

Dimensions for external handles

SIRCO M1 and M2

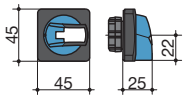
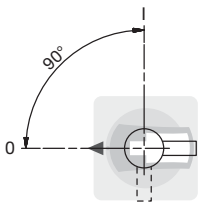
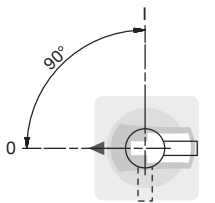
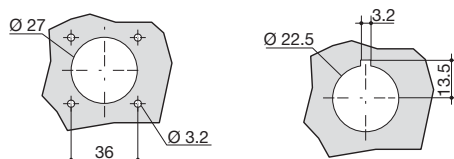
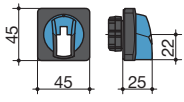
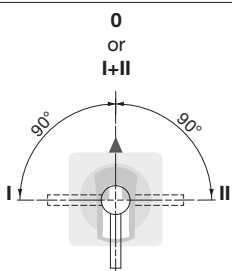
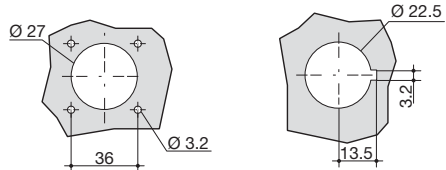
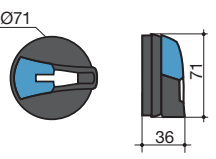
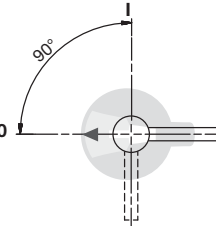
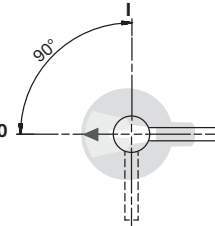
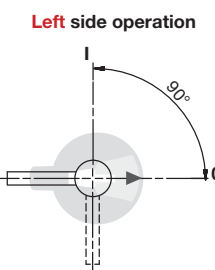
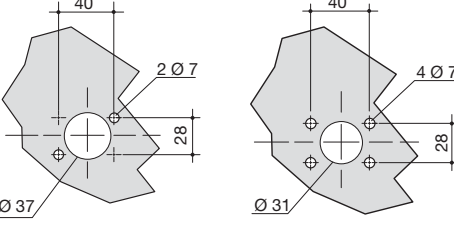
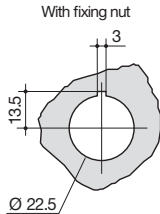
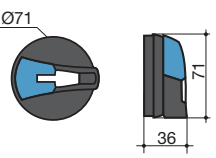
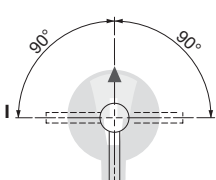
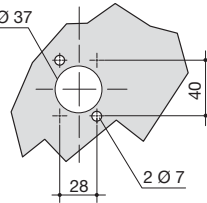
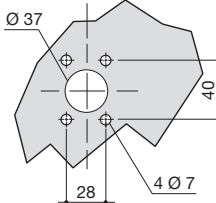
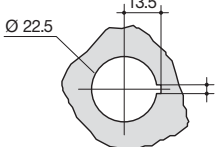
<p>Handle type</p> <p>S000 type Load break switches</p> 	<p>Front operation Direction of operation</p> 	<p>Side operation Direction of operation</p> <p>Right side operation</p> 	<p>Door drilling</p> <p>With 4 fixing screws With fixing nut</p> 	
<p>Handle type</p> <p>S000 type Transfer switches I-0-II and I - I+II - II</p> 	<p>Front operation Direction of operation</p> <p>0 or I+II</p> 		<p>Door drilling</p> <p>With 4 fixing screws With fixing nut</p> 	
<p>Handle type</p> <p>S00 type Load break switches</p> 	<p>Front operation Direction of operation</p> 	<p>Side operation Direction of operation</p> <p>Right side operation</p>  <p>Left side operation</p> 	<p>Door drilling</p> <p>IP55 with 2 fixing clips IP65 with 4 fixing screws</p>  <p>With fixing nut</p> 	
<p>Handle type</p> <p>S00 type Transfer switches I-0-II and I - I+II - II</p> 	<p>Front operation Direction of operation</p> <p>0 or I+II</p> 	<p>IP55 with 2 fixing clips</p> 	<p>IP65 with 4 fixing screws</p> 	<p>With fixing nut</p> 

polgn_016_a_1_gb_cat

polgn_017_b_1_gb_cat

polgn_024_a_1_gb_cat

polgn_025_b_1_gb_cat

SIRCO M and SIRCO MV

Universal load break switches

from 16 to 160 A

Dimensions for external handles

SIRCO M1 and M2 - 3/4 P and 6/8 P

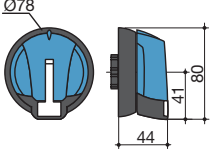
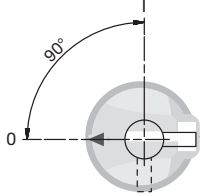
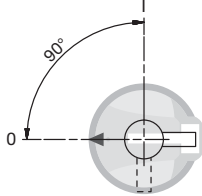
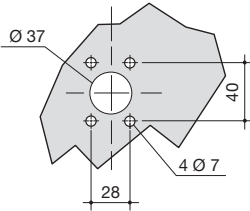
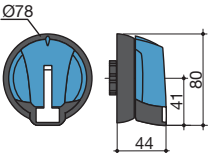
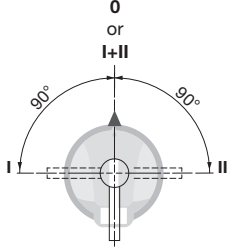
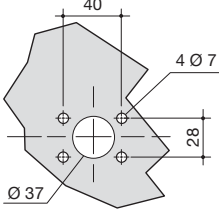
Handle type	Front operation Direction of operation	Side operation Direction of operation	Door drilling
S01 type Load break switches 		Right side operation 	Door drilling IP65 with 4 fixing screws 
S01 type Transfer switches I-0-II and I - I+II - II 	Front operation Direction of operation 		Door drilling IP65 with 4 fixing screws 

poign_018_a_1_gb_cat

poign_019_b_1_gb_cat

SIRCO M3

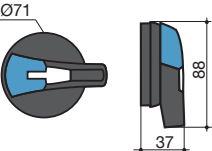
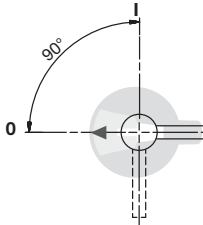
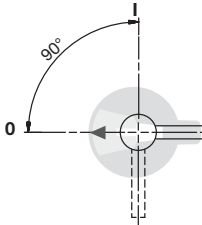
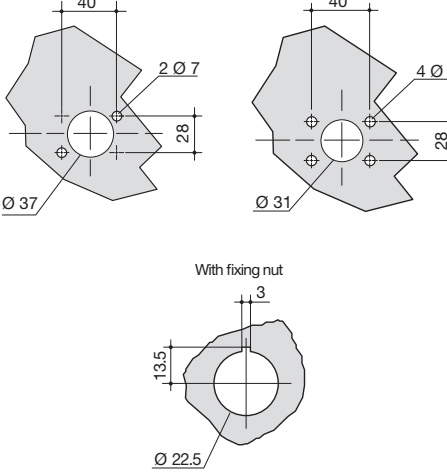
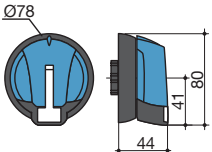
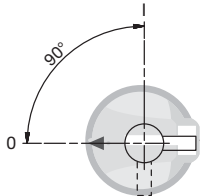
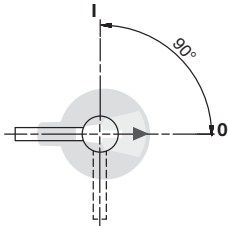
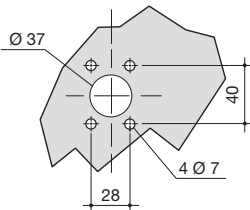
Handle type	Front operation Direction of operation	Side operation Direction of operation	Door drilling
S0 type Load break switches 		Right side operation 	Door drilling IP55 with 2 fixing clips IP65 with 4 fixing screws 
S01 type Load break switches 		Left side operation 	Door drilling IP65 with 4 fixing screws 

poign_026_a_1_gb_cat

poign_018_a_1_gb_cat

SIRCO MV

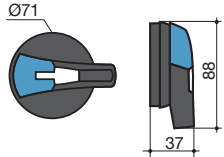
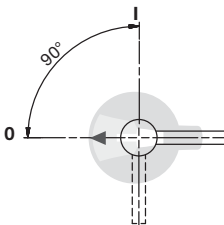
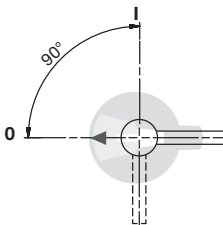
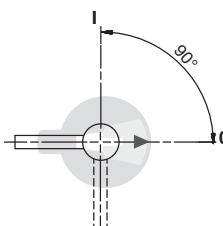
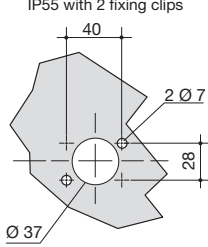
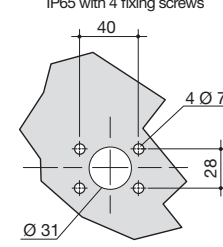
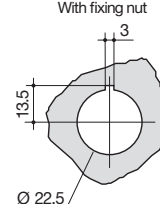
Handle type	Front operation Direction of operation	Side operation Direction of operation	Door drilling	
S0 type Load break switches 		Right side operation  Left side operation 	IP55 with 2 fixing clips  IP65 with 4 fixing screws  With fixing nut 	

poign_026_a_1_gb_cat

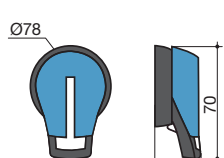
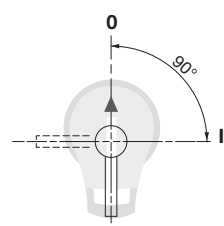
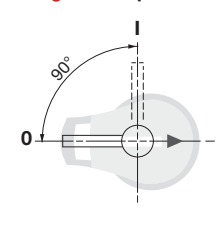
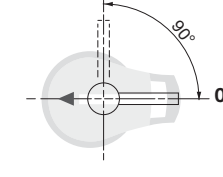
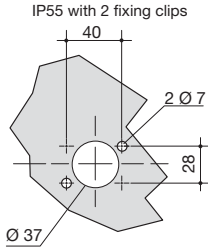
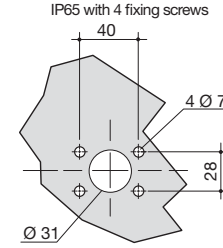
Handle type	Front operation Direction of operation	Side operation Direction of operation	Door drilling	
S1 type Load break switches 		Right side operation  Left side operation 	IP55 with 2 fixing clips  IP65 with 4 fixing screws 	

poign_027_a_1_gb_cat

SIRCO

Load break switches for power distribution from 125 to 5000 A

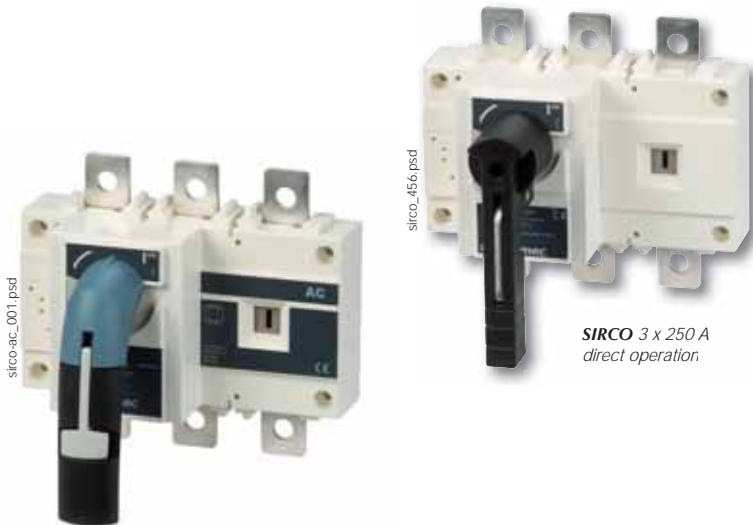

Function

SIRCO and **SIRCO AC** are manually or remotely operated multipolar load break switches. They make and break under load conditions and provide safe isolation. SIRCO are designed for 415 VAC and DC low voltage electrical circuits. SIRCO AC are designed for heavy duty applications up to 1000 VAC - AC 23.

General characteristics

- Double positive break indication given through a position indication window, located directly on the product, and by the operating handle.
- Severe load duty categories (AC-22 and AC-23).
- High resistance to damp heat (supplied "tropicalised").

Advantages

Reliability and performance

The double breaking per pole, achieved through its sliding bar contact system, is a proven design that offers very high durability and short-circuit withstand. Improved breaking performance with quick opening and rapid closure.

Safety of property and personnel

The position indicator is located directly on the sliding bar contact mechanism, ensuring it can be seen in all circumstances.

The use of glass fibre reinforced polyester gives the SIRCO and SIRCO AC both high mechanical and thermal resistance.

Simplicity

The standardisation of the SIRCO and SIRCO AC range and its wide choice of common accessories enable:

- Simple mounting.
- Reduced stock management and storage costs.

Easy to install

The outdoors ranges are easy to install thanks to:

- A good centre-to-centre distance (up to 120 mm).
- Connection up to 6 x 185 mm².
- Connection accessories which facilitate both flat and edgewise connections.

The solution for

- > Main switchboard
- > Distribution panel
- > Emergency breaking
- > Network coupling
- > Local safety breaking



Strong points

- > Reliability and performance
- > Safety of property and personnel
- > Simplicity
- > Easy to install

Compliance with standards

- > IEC 60947-3



Approvals and certifications⁽¹⁾



**BUREAU
VERITAS**

⁽¹⁾ Product reference on request.

Enclosures

- > The SIRCO and SIRCO AC range can be easily fitted in our enclosures and cabinets designed for electrical distribution.



What you need to know

- In front **direct** or **external** operation, SIRCO is available in 3 and 4-pole versions from 125 to 5000 A.
- It can be ordered in 6 or 8-pole versions from 125 to 1600 A.
- SIRCO is available in a polyester or sheet metal enclosure from 125 to 1250 A.

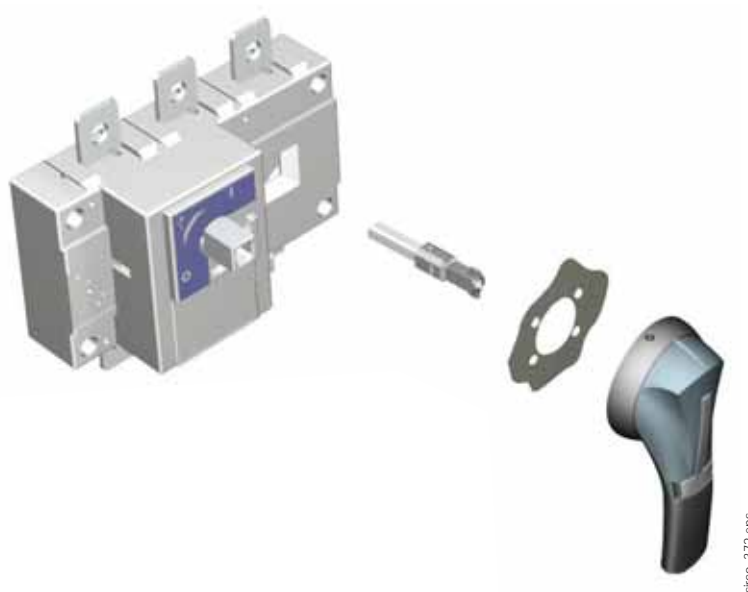

For ratings 2000, 2500 and 3200A, a copper **bar connection kit** enables the connection between the two power terminals of one pole.

Flat connection
top or bottom



Edgewise connection
top or bottom

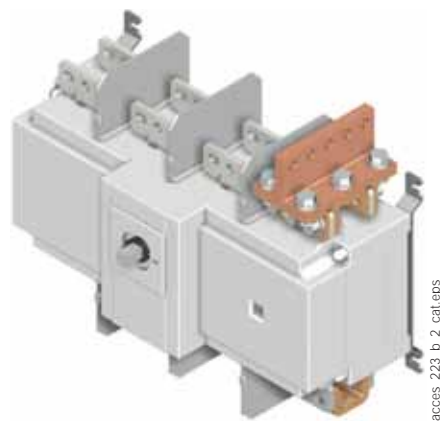

SIRCO

Load break switches for power distribution
from 125 to 5000 A

SIRCO - References

Standard applications - Front operation - 3 & 4-pole

Rating (A) / Frame size	No. of poles	Switch body ⁽¹⁾	Direct handle	External handle	Shaft for external handle	Auxiliary contact	Terminal shrouds	Terminal screens
125 A / B3	3 P	2600 3014	J0 type Black				3 P	3 P
	4 P	2600 4014	1102 1111 ⁽²⁾ Red				2694 3014 ⁽³⁾ 4 P	2698 3012 ⁽³⁾ 4 P
160 A / B3	3 P	2600 3017	1103 1111				4 P	4 P
	4 P	2600 4017					2694 4014 ⁽³⁾	2698 4012 ⁽³⁾
200 A / B4	3 P	2600 3021					3 P	3 P
	4 P	2600 4021					2694 3021 ⁽³⁾ 4 P	2698 3020 ⁽³⁾ 4 P
250 A / B4	3 P	2600 3026		S2 type Black IP55 1421 2111 ⁽²⁾ Black IP65 1423 2111 Red IP65 1424 2111	200 mm 1400 1020 320 mm 1400 1032 ⁽²⁾ 500 mm 1400 1050		4 P	4 P
	4 P	2600 4026					2694 4021 ⁽³⁾	2698 4020 ⁽³⁾
315 A / B5	3 P	2600 3032	J1 type Black 1112 1111 Red 1113 1111					
	4 P	2600 4032						
400 A / B5	3 P	2600 3041						
	4 P	2600 4041						
500 A / B5	3 P	2600 3051						
	4 P	2600 4051						
630 A / B5	3 P	2600 3064						
	4 P	2600 4064						
800 A / B6	3 P	2600 3081				1 st NO/NC contact 2699 0031 2 nd NO/NC contact 2699 0032		
	4 P	2600 4081						
1000 A / B6	3 P	2600 3099						3 P 2698 3080 ⁽³⁾ 4 P 2698 4080 ⁽³⁾
	4 P	2600 4099						
CD 1250 A / B6	3 P	2600 3119	J4 type Blue 1142 1111 ⁽²⁾ Red 1143 1111	Type S4 Black IP65 1443 3111 ⁽²⁾ Red IP65 1444 3111	200 mm 1401 1520 320 mm 1401 1532 ⁽²⁾ 400 mm 1401 1540			
	4 P	2600 4119						
1250 A / B7	3 P	2600 3121						
	4 P	2600 4121						
1600 A / B7	3 P	2600 3161						3 P 2698 3120 ⁽³⁾ 4 P 2698 4120 ⁽³⁾
	4 P	2600 4161						
1800 A / B7	3 P	2600 3181						
	4 P	2600 4181						
2000 A / B8	3 P	2600 3200						
	4 P	2600 4200						
2500 A / B8	3 P	2600 3250	S5 type Black 2799 7042 ⁽²⁾ Red 2799 7043	V2 type Black IP65 2799 7136 ⁽²⁾ Red IP65 2799 7134	200 mm 2799 3015 320 mm 2799 3018 ⁽²⁾ 450 mm 2799 3019			3 P 2698 3200 ⁽³⁾ 4 P 2698 4200 ⁽³⁾
	4 P	2600 4250						
3200 A / B8	3 P	2600 3320						
	4 P	2600 4320						
4000 A / B9	3 P	2600 3401	V0 type Black 2799 7072 ⁽²⁾	V0 type Black IP65 2799 7155 ⁽²⁾				
	4 P	2600 4401						
5000 A / B9	3 P	2600 3500				1 st /2 nd NO/NC contact included		
	4 P	2600 4500						

(1) Device available enclosed, see "Enclosed load break switches" pages.

(2) Standard.

(3) Top or bottom.

SIRCO AC - References

Heavy duty applications - Front operation 3 & 4 pole

Rating (A) / Frame size	No. of poles	Switch body	Direct handle	External handle	Shaft for external handle	Auxiliary contact	Terminal shrouds	Terminal screens																				
200 A / B4	3 P	26AC 3020	J1 type Black 1112 1111 ⁽¹⁾ J1 type Red 1113 1111	S2 type Black IP65 1421 2111 ⁽¹⁾ Black IP65 1423 2111 Red IP65 1424 2111	200 mm 1400 1020 320 mm 1400 1032 ⁽¹⁾ 500 mm 1400 1050		3P 2694 3021 ⁽²⁾⁽³⁾ 4 P 2694 4021 ⁽²⁾⁽³⁾	3P 2698 3020 ⁽³⁾ 4 P 2698 4020 ⁽³⁾																				
	4 P	26AC 4020																										
250 A / B4	3 P	26AC 3025					J1 type Black 1112 1111 ⁽¹⁾ J1 type Red 1113 1111	S2 type Black IP65 1421 2111 ⁽¹⁾ Black IP65 1423 2111 Red IP65 1424 2111	200 mm 1400 1020 320 mm 1400 1032 ⁽¹⁾ 500 mm 1400 1050		3P 2694 3021 ⁽²⁾⁽³⁾ 4 P 2694 4021 ⁽²⁾⁽³⁾	3P 2698 3020 ⁽³⁾ 4 P 2698 4020 ⁽³⁾																
	4 P	26AC 4025																										
315 A / B4	3 P	26AC 3031									J1 type Black 1112 1111 ⁽¹⁾ J1 type Red 1113 1111	S2 type Black IP65 1421 2111 ⁽¹⁾ Black IP65 1423 2111 Red IP65 1424 2111	200 mm 1400 1020 320 mm 1400 1032 ⁽¹⁾ 500 mm 1400 1050		3P 2694 3021 ⁽²⁾⁽³⁾ 4 P 2694 4021 ⁽²⁾⁽³⁾	3P 2698 3020 ⁽³⁾ 4 P 2698 4020 ⁽³⁾												
	4 P	26AC 4031																										
400 A / B5	3 P	26AC 3040													J1 type Black 1112 1111 ⁽¹⁾ J1 type Red 1113 1111	S2 type Black IP65 1421 2111 ⁽¹⁾ Black IP65 1423 2111 Red IP65 1424 2111	200 mm 1400 1020 320 mm 1400 1032 ⁽¹⁾ 500 mm 1400 1050		3P 2694 3021 ⁽²⁾⁽³⁾ 4 P 2694 4021 ⁽²⁾⁽³⁾	3P 2698 3020 ⁽³⁾ 4 P 2698 4020 ⁽³⁾								
	4 P	26AC 4040																										
500 A / B5	3 P	26AC 3050																	J1 type Black 1112 1111 ⁽¹⁾ J1 type Red 1113 1111	S2 type Black IP65 1421 2111 ⁽¹⁾ Black IP65 1423 2111 Red IP65 1424 2111	200 mm 1400 1020 320 mm 1400 1032 ⁽¹⁾ 500 mm 1400 1050		3P 2694 3021 ⁽²⁾⁽³⁾ 4 P 2694 4021 ⁽²⁾⁽³⁾	3P 2698 3020 ⁽³⁾ 4 P 2698 4020 ⁽³⁾				
	4 P	26AC 4050																										
CD 630 A / B5	3 P	26AC 3063																					J1 type Black 1112 1111 ⁽¹⁾ J1 type Red 1113 1111	S2 type Black IP65 1421 2111 ⁽¹⁾ Black IP65 1423 2111 Red IP65 1424 2111	200 mm 1400 1020 320 mm 1400 1032 ⁽¹⁾ 500 mm 1400 1050		3P 2694 3021 ⁽²⁾⁽³⁾ 4 P 2694 4021 ⁽²⁾⁽³⁾	3P 2698 3020 ⁽³⁾ 4 P 2698 4020 ⁽³⁾
	4 P	26AC 4063																										
630 A / B6	3 P	26AC 3064	J4 type Blue 1142 1111 ⁽¹⁾ Red 1143 1111	S4 type Black IP65 1443 3111 ⁽¹⁾ Red IP65 1444 3111	200 mm 1401 1520 320 mm 1401 1532 ⁽¹⁾ 400 mm 1401 1540	1 st contact NO/NC 2699 0031 2 nd contact NO/NC 2699 0032																						3 P 2698 3080 ⁽²⁾⁽³⁾ 4 P 2698 4080 ⁽²⁾⁽³⁾
	4 P	26AC 4064																										
800 A / B6	3 P	26AC 3080					J4 type Blue 1142 1111 ⁽¹⁾ Red 1143 1111	S4 type Black IP65 1443 3111 ⁽¹⁾ Red IP65 1444 3111	200 mm 1401 1520 320 mm 1401 1532 ⁽¹⁾ 400 mm 1401 1540	1 st contact NO/NC 2699 0031 2 nd contact NO/NC 2699 0032																		3 P 2698 3080 ⁽²⁾⁽³⁾ 4 P 2698 4080 ⁽²⁾⁽³⁾
	4 P	26AC 4080																										
1000 A / B6	3 P	26AC 3100									J4 type Blue 1142 1111 ⁽¹⁾ Red 1143 1111	S4 type Black IP65 1443 3111 ⁽¹⁾ Red IP65 1444 3111	200 mm 1401 1520 320 mm 1401 1532 ⁽¹⁾ 400 mm 1401 1540	1 st contact NO/NC 2699 0031 2 nd contact NO/NC 2699 0032														3 P 2698 3080 ⁽²⁾⁽³⁾ 4 P 2698 4080 ⁽²⁾⁽³⁾
	4 P	26AC 4100																										
CD 1250 A / B6	3 P	26AC 3120													J4 type Blue 1142 1111 ⁽¹⁾ Red 1143 1111	S4 type Black IP65 1443 3111 ⁽¹⁾ Red IP65 1444 3111	200 mm 1401 1520 320 mm 1401 1532 ⁽¹⁾ 400 mm 1401 1540	1 st contact NO/NC 2699 0031 2 nd contact NO/NC 2699 0032										3 P 2698 3080 ⁽²⁾⁽³⁾ 4 P 2698 4080 ⁽²⁾⁽³⁾
	4 P	26AC 4120																										
1250 A / B7	3 P	26AC 3121																	J4 type Blue 1142 1111 ⁽¹⁾ Red 1143 1111	S4 type Black IP65 1443 3111 ⁽¹⁾ Red IP65 1444 3111	200 mm 1401 1520 320 mm 1401 1532 ⁽¹⁾ 400 mm 1401 1540	1 st contact NO/NC 2699 0031 2 nd contact NO/NC 2699 0032						3 P 2698 3120 ⁽²⁾⁽³⁾ 4 P 2698 4120 ⁽²⁾⁽³⁾
	4 P	26AC 4121																										
1600 A / B7	3 P	26AC 3160																					J4 type Blue 1142 1111 ⁽¹⁾ Red 1143 1111	S4 type Black IP65 1443 3111 ⁽¹⁾ Red IP65 1444 3111	200 mm 1401 1520 320 mm 1401 1532 ⁽¹⁾ 400 mm 1401 1540	1 st contact NO/NC 2699 0031 2 nd contact NO/NC 2699 0032		3 P 2698 3120 ⁽²⁾⁽³⁾ 4 P 2698 4120 ⁽²⁾⁽³⁾
	4 P	26AC 4160																										
2000 A / B8	3 P	26AC 3200	S5 type Black 2799 7042 ⁽¹⁾ Red 2799 7043	S5 type Black IP65 1453 8111 ⁽¹⁾ Red IP65 1454 8111	200 mm 2799 3015 320 mm 2799 3018 ⁽¹⁾ 450 mm 2799 3019																							3 P 2698 3200 ⁽²⁾⁽³⁾ 4 P 2698 4200 ⁽²⁾⁽³⁾
	4 P	26AC 4200																										
4000 A / B9	3 P	consult us					V0 type Black 2799 7072 ⁽¹⁾	V0 type Black 2799 7155 ⁽¹⁾	200 mm 2799 3015 320 mm 2799 3018 ⁽¹⁾ 450 mm 2799 3019	1 st / 2 nd included																		3/4P 1509 4200 ⁽⁴⁾
	4 P	consult us																										

(1) Standard.

(2) Mandatory for voltage greater than 415 VAC.

(3) Top or bottom.

(4) Top and bottom.

SIRCO

Load break switches for power distribution
from 125 to 5000 A

SIRCO - References

Standard applications - Front operation - 6 & 8-pole

Rating (A) / Frame size	No. of poles	Switch body	Direct handle	External handle	Shaft for external handle	Auxiliary contact	Terminal shrouds	Terminal screens
125 A / B3 _{DS}	6 P	2601 6013	J2 type Black 1122 1111 ⁽¹⁾ Red 1123 1111	S2 type Black IP55 1421 2111 ⁽¹⁾ Red IP65 1424 2111	200 mm 1400 1020 320 mm 1400 1032 ⁽¹⁾		6 P 2694 3014 ⁽²⁾⁽³⁾ 8 P 2694 4014 ⁽²⁾⁽³⁾	6 P 1509 3012 ⁽⁴⁾ 8 P 1509 4012 ⁽⁴⁾
	8 P	2601 8013						
160 A / B3 _{DS}	6 P	2601 6016						
	8 P	2601 8016						
250 A / B4 _{DS}	6 P	2601 6025					6 P 2694 3021 ⁽²⁾⁽³⁾ 8 P 2694 4021 ⁽²⁾⁽³⁾	6 P 1509 3025 ⁽⁴⁾ 8 P 1509 4025 ⁽⁴⁾
	8 P	2601 8025						
400 A / B5 _{DS}	6 P	2601 6040	J3 type Black 1132 1111 ⁽¹⁾ Red 1133 1111	Type S4 Black IP65 1443 3111 ⁽¹⁾ Red IP65 1444 3111	200 mm 1401 1520 320 mm 1401 1532 ⁽¹⁾		6 P 2694 3051 ⁽²⁾⁽³⁾ 8 P 2694 4051 ⁽²⁾⁽³⁾	6 P 1509 3063 ⁽⁴⁾ 8 P 1509 4063 ⁽⁴⁾
	8 P	2601 8040						
630 A / B5 _{DS}	6 P	2601 6063				1 st NO/NC contact 2699 0061 2 nd NO/NC contact 2699 0062		
	8 P	2601 8063						
800 A / B6 _{DS}	6 P	2601 6080						
	8 P	2601 8080						
1000 A / B6 _{DS}	6 P	2601 6100	J4 type Blue 1142 1111 ⁽²⁾ Red 1143 1111	Type V1 Black IP65 2799 7145 ⁽¹⁾	320 mm 2799 3018 ⁽¹⁾			6 P 1509 3080 ⁽⁴⁾ 8 P 1509 4080 ⁽⁴⁾
	8 P	2601 8100						
1250 A / B7 _{DS}	6 P	2601 6120						
	8 P	2601 8120						
1600 A / B7 _{DS}	6 P	2601 6160						6 P 1509 3160 ⁽⁴⁾ 8 P 1509 4160 ⁽⁴⁾
	8 P	2601 8160						

(1) Standard.

(2) Top or bottom on the front or rear of the device.

(3) Select 2 sets for front or rear.

(4) Top or bottom at the front of the device.

Accessories

Direct operation handle

SIRCO direct operation handle				
Rating (A) / Frame size	No. of poles	Handle type	Handle colour	Reference
125 ... 160 / B3	3/4 P	J0	Black	1102 1111 ⁽¹⁾
125 ... 160 / B3	3/4 P	J0	Red	1103 1111
125 ... 160 / B3 _{DS}	6/8 P	J2	Black	1122 1111 ⁽¹⁾
125 ... 160 / B3 _{DS}	6/8 P	J2	Red	1123 1111
200 ... 630 / B4-B5	3/4 P	J1	Black	1112 1111 ⁽¹⁾
200 ... 630 / B4-B5	3/4 P	J1	Red	1113 1111
250 ... 630 / B4 _{DS} -B5 _{DS}	6/8 P	J3	Black	1132 1111 ⁽¹⁾
250 ... 630 / B4 _{DS} -B5 _{DS}	6/8 P	J3	Red	1133 1111
800 ... 1800 / B6...B7	3/4 P	J4	Blue	1142 1111 ⁽¹⁾
800 ... 1800 / B6...B7	3/4 P	J4	Red	1143 1111
800 ... 1600 / B6 _{DS} -B7 _{DS}	6/8 P	J4	Blue	1142 1111 ⁽¹⁾
800 ... 1600 / B6 _{DS} -B7 _{DS}	6/8 P	J4	Red	1143 1111
1800 ... 3200 / B8	3/4P	S5	Black	2799 7042 ⁽¹⁾
1800 ... 3200 / B8	3/4P	S5	Red	2799 7043
4000 ... 5000 / B9	3/4 P	V0	Black	2799 7072 ⁽¹⁾

(1) Standard.

SIRCO AC direct operation handle				
Rating (A) / Frame size	No. of poles	Handle type	Handle colour	Reference
200 ... CD 630 / B4 ... B5	3/4 P	J1	Black	1112 1111 ⁽¹⁾
200 ... CD 630 / B4 ... B5	3/4 P	J1	Red	1113 1111
630 ... 1600 / B6 ... B7	3/4 P	J4	Blue	1142 1111 ⁽¹⁾
630 ... 1600 / B6 ... B7	3/4 P	J4	Red	1143 1111
2000 / B8	3/4 P	S5	Black	2799 7042 ⁽¹⁾
2000 / B8	3/4 P	S5	Red	2799 7043
4000 / B9	3/4 P	V0	Black	2799 7072 ⁽¹⁾

(1) Standard.



Door interlocked external operation handle

SIRCO and SIRCO AC external front operation handle						
Rating (A) / Frame size		No. of poles	Handle type	Handle colour	External IP ⁽¹⁾	Reference
SIRCO	SIRCO AC					
125 ... 630 / B3 ... B5	200 ... CD 630 / B4 ... B5	3/4 P	S2	Black	IP55	1421 2111 ⁽²⁾
				Black	IP65	1423 2111
				Red	IP65	1424 2111
				Black	IP55	1421 2111 ⁽²⁾
125 ... 160 / B3 _{DS}	-	6/8 P	S2	Black	IP65	1423 2111
				Red	IP65	1424 2111
				Black	IP65	1443 3111
250 ... 630 / B4 _{DS} -B5 _{DS}	-	6/8 P	S4	Black	IP65	1444 3111
800 ... 1600 / B6 _{DS} -B7 _{DS}	-	6/8 P	V1	Black	IP65	2799 7145 ⁽²⁾
800 ... 1800 / B6-B7	630 ... 1600 / B6 ... B7	3/4 P	S4	Black	IP65	1443 3111 ⁽²⁾
				Red	IP65	1444 3111
2000 ... 3200 / B8	2000 / B8	3/4 P	V2	Black	IP65	2799 7136 ⁽²⁾
				Red	IP65	2799 7134
			S5	Black	IP65	1453 8111
4000 ... 5000 / B9	4000 / B9	3/4 P	V0	Black	IP65	2799 7155 ⁽²⁾

(1) IP: protection degree according to IEC 60529 standard.

(2) Standard.

Use

Door interlocked external operation handles include an escutcheon, are padlockable and must be utilised with an extension shaft.



SIRCO

Load break switches for power distribution
from 125 to 5000 A

Accessories (continued)

Shaft for external operation

For 3/4 pole SIRCO and SIRCO AC

Rating (A) / Frame size		Dimension X (mm)	Length (mm)	Reference
SIRCO	SIRCO AC			
125 ... 160 / B3		125 ... 250	200	1400 1020
		125 ... 300	250	1400 1025
		125 ... 370	320	1400 1032
		125 ... 550	500	1400 1050
		125 ... 850	750	1400 1075
200 ... 250 / B4	200 ... 315 / B4	135 ... 265	200	1400 1020
		135 ... 315	250	1400 1025
		135 ... 385	320	1400 1032
		135 ... 565	500	1400 1050
		135 ... 880	750	1400 1075
315 ... 630 / B5	400 ... CD 630 / B5	165 ... 295	200	1400 1020
		165 ... 345	250	1400 1025
		165 ... 415	320	1400 1032
		165 ... 595	500	1400 1050
800 ... 1800 / B6...B7	630 ... 1600 / B6 ... B7	221 ... 343	200	1401 1520
		221 ... 463	320	1401 1532
		221 ... 543	400	1401 1540
2000 ... 3200 / B8	2000 / B8	415 ... 570	200	2799 3015
		415 ... 690	320	2799 3018
		415 ... 820	450	2799 3019
4000 ... 5000 / B9	4000 / B9	550 ... 680	200	2799 3015
		651 ... 921	320	2799 3018

For 6/8-pole SIRCO

Rating (A) / Frame size	Dimension X (mm)	Length (mm)	Reference
125 ... 160 / B3 _{DS}	270 ... 436	200	1400 1020
125 ... 160 / B3 _{DS}	270 ... 556	320	1400 1032
250 ... 630 / B4 _{DS} -B5 _{DS}	221 ... 308	200	1401 1520
250 ... 630 / B4 _{DS} -B5 _{DS}	221 ... 428	320	1401 1532
250 ... 630 / B4 _{DS} -B5 _{DS}	221 ... 508	400	1401 1540

Use
Standard lengths:

- 200 mm
- 250 mm
- 300 mm
- 400 mm
- 500 mm
- 750 mm

Other lengths available:
- please consult us.



access_368.eps



access_144.eps

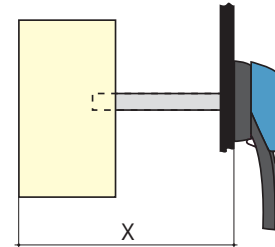

access_202_a_1_x_cat

Alternative handle cover colours

Use
For S type handles.

Handle colour	To be ordered in multiples of	Handle type	Reference
Light grey	50	S2, S3	1401 0001
Dark grey	50	S2, S3	1401 0011
Light grey	50	S4	1401 0031
Dark grey	50	S4	1401 0041



S type cover

access_198.eps

S type handle adapter

Use
Adds 12 mm to the depth of the handle.

Handle colour	To be ordered in multiples of	External IP ⁽¹⁾	Reference
Black	1	IP65	1493 0000

(1) IP: protection degree according to IEC 60529 standard.



access_187.eps

Shaft guide for external operation

Use

For use with S-type handles, to guide the shaft extension into the external handle. This accessory enables the handle to engage the extension shaft with a misalignment of up to 15 mm. Recommended for shaft lengths over 320 mm.



access_260.eps

Description	Reference
Shaft guide	1429 0000

Auxiliary contact

Use

Pre-break and signalling of positions 0 and I:
- 1 to 2 NO/NC auxiliary contacts.
- 1 to 4 NO+NC auxiliary contacts.
- 1 to 2 low level NO/NC auxiliary contacts.

Characteristics

NO/NC A/C: IP20 with front operation.

Connection to the control circuit

6.35 mm fast-on terminal.

Electrical characteristics

30 000 operations.

NO/NC contact for 3/4 pole SIRCO and SIRCO AC		
Rating (A) / Frame size	Position A/C	Reference
125 ... 3200 / B3 ... B8	1 st	2699 0031
125 ... 3200 / B3 ... B8	2 nd	2699 0032
4000 ... 5000 / B9	1 st /2 nd	included

NO/NC contact for 6/8 pole SIRCO		
Rating (A) / Frame size	Position A/C	Reference
125 ... 1600 / B3 _{DS} ... B7 _{DS}	1 st	2699 0061
125 ... 1600 / B3 _{DS} ... B7 _{DS}	2 nd	2699 0062

NO+NC contact for 3/4 pole SIRCO and SIRCO AC		
Rating (A) / Frame size	Position A/C	Reference
125 ... 3200 / B3 ... B8	1 st	2699 0141
125 ... 3200 / B3 ... B8	2 nd /3 rd /4 th	2699 0142

NO/NC low level contact for 3/4 pole SIRCO and SIRCO AC		
Rating (A) / Frame size	Position A/C	Reference
125 ... 3200 / B3 ... B8	1 st	2699 0301
125 ... 3200 / B3 ... B8	2 nd	2699 0302

Characteristics

Rating (A) / Frame size	Contact type	Current nominal (A)	Operating current I _o (A)									
			230 VAC		400 VAC		24 VDC			48 VDC		
			AC-12	AC-13/15	AC-12	AC-13/15	DC-12	DC-13	DC-14	DC-12	DC-13	DC-14
125 ... 3200 / B3 ... B8	NO/NC	16	16	4	12	3	2.5	2.5	1	2.5	1.2	0.2
125 ... 3200 / B3 ... B8	NO + NC	16	16	4	16	3	16	5	1	2.5	1.2	0.2

Inter-phase barrier

Use

Safe isolation between the terminals, essential for use at 690 VAC or in a polluted or dusty atmosphere.

For 3/4 poles SIRCO and SIRCO AC

Rating (A) / Frame size			
SIRCO	SIRCO AC	No. of poles	Reference
125 ... 160 / B3		3 P	2998 0033
125 ... 160 / B3		4 P	2998 0034
200 ... 250 / B4	200 ... 315 / B4	3 P	2998 0023
200 ... 250 / B4	200 ... 315 / B4	4 P	2998 0024
315 ... 630 / B5	315 ... CD 630 / B5	3 P	2998 0013
315 ... 630 / B5	315 ... CD 630 / B5	4 P	2998 0014
800 ... 5000 / B6 ... B9	630 ... 4000 / B6 ... B9	3 P	included
800 ... 5000 / B6 ... B9	630 ... 4000 / B6 ... B9	4 P	included



access_036.eps

SIRCO

Load break switches for power distribution
from 125 to 5000 A

Accessories (continued)

Terminal shrouds

Use

Top or bottom protection against direct contact with terminals or connection parts.

Advantage

Perforations allow remote thermographic inspection without the need to remove the shrouds. The terminal shrouds also provide phase separation for SIRCO and SIRCO AC from 125 to 630 A.



access_077.eps

For 3/4 poles SIRCO and SIRCO AC

Rating (A) / Frame size		No. of poles	Position	Reference
SIRCO	SIRCO AC			
125 ... 160 / B3		3 P	top or bottom	2694 3014 ⁽¹⁾
125 ... 160 / B3		4 P	top or bottom	2694 4014 ⁽²⁾
200 ... 250 / B4	200 ... 315 / B4	3 P	top or bottom	2694 3021 ⁽¹⁾
200 ... 250 / B4	200 ... 315 / B4	4 P	top or bottom	2694 4021 ⁽²⁾
315 ... 630 / B5	400 ... CD 630 / B5	3 P	top or bottom	2694 3051 ⁽¹⁾
315 ... 630 / B5	400 ... CD 630 / B5	4 P	top or bottom	2694 4051 ⁽²⁾

(1) Reference includes 3 parts for top or bottom protection.

(2) Reference includes 4 parts for top or bottom protection.

For 6/8-pole SIRCO

Rating (A) / Frame size	No. of poles	Position	Reference
125 ... 160 / B3 _{DS}	6 P	Top or bottom	2694 3014 ⁽¹⁾⁽³⁾
125 ... 160 / B3 _{DS}	8 P	Top or bottom	2694 4014 ⁽²⁾⁽³⁾
250 / B4 _{DS}	6 P	Top or bottom	2694 3021 ⁽¹⁾⁽³⁾
250 / B4 _{DS}	8 P	Top or bottom	2694 4021 ⁽²⁾⁽³⁾
400 ... 630 / B5 _{DS}	6 P	Top or bottom	2694 3051 ⁽¹⁾⁽³⁾
400 ... 630 / B5 _{DS}	8 P	Top or bottom	2694 4051 ⁽²⁾⁽³⁾

(1) Reference includes 3 parts for top or bottom protection on the front or rear of the device.

(2) Reference includes 4 parts for top or bottom protection on the front or rear of the device.

(3) Select 2 sets for front or rear.

Distribution block

Use

Easy connection of multiple cables, bottom of the SIRCO.

For 3/4-pole SIRCO

Rating (A) / Frame size	No. of poles	No. of feeders per section (mm ²)	I _{cc} (kA rms) ⁽¹⁾	Reference
160 / B3	3 P	1x95 + 8x25	10	5411 3016
160 / B3	4 P	1x95 + 8x25	10	5411 4016
250 / B4	3 P	1x150 + 8x50	15	5411 3025
250 / B4	4 P	1x150 + 8x50	15	5411 4025
400 / B5	3 P	1x240 + 8x95	21	5411 3040
400 / B5	4 P	1x240 + 8x95	21	5411 4040
630 / B5	3 P	1x300 + 8x150	21	5411 3063
630 / B5	4 P	1x300 + 8x150	21	5411 4063

Dimensions

Rating (A) / Frame size	No. of poles	A	B	T	H	K	P	R	T	Y
160 / B3	3 P	154	286	73	46.5	261.5	36	20	4	54
160 / B3	4 P	190	286	73	46.5	261.5	36	20	4	54
250 / B4	3 P	210	307	83	57.5	279	50	25	4	56
250 / B4	4 P	260	307	83	57.5	279	50	25	4	56
400 / B5	3 P	281	375	116	82.5	340	65	32	5	82
400 / B5	4 P	346	375	116	82.5	340	65	32	5	82
630 / B5	3 P	271	438	117	90.5	410.5	65	40	6	83
630 / B5	4 P	346	438	117	90.5	410.5	65	40	6	83



repair_020.psd

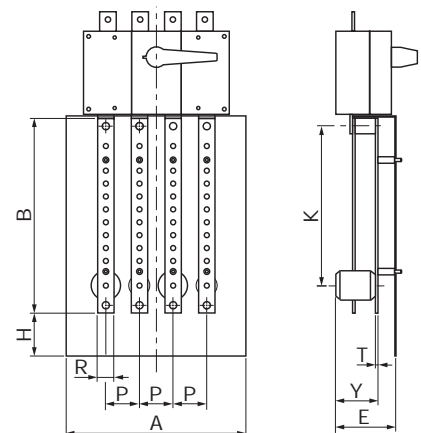

repair_003_of_1_x_cat.ctb

Terminal screens

Use

Top or bottom protection from direct contact with terminals or connection parts.

For 3/4 poles SIRCO and SIRCO AC

Rating (A) / Frame size		No. of poles	Position	Reference
SIRCO	SIRCO AC			
125 ... 160 / B3		3 P	top or bottom	2698 3012
125 ... 160 / B3		4 P	top or bottom	2698 4012
200 ... 250 / B4	200 ... 315 / B4	3 P	top or bottom	2698 3020
200 ... 250 / B4	200 ... 315 / B4	4 P	top or bottom	2698 4020
315 ... 630 / B5	400 ... CD 630 / B5	3 P	top or bottom	2698 3050
315 ... 630 / B5	400 ... CD 630 / B5	4 P	top or bottom	2698 4050
800 ... CD 1250 / B6	630 ... CD 1250 / B6	3 P	top or bottom	2698 3080
800 ... CD 1250 / B6	630 ... CD 1250 / B6	4 P	top or bottom	2698 4080
1250 ... 1800 / B7	1250 ... 1600 / B7	3 P	top or bottom	2698 3120
1250 ... 1800 / B7	1250 ... 1600 / B7	4 P	top or bottom	2698 4120
2000 ... 3200 / B8	2000 / B8	3 P	top or bottom	2698 3200
2000 ... 3200 / B8	2000 / B8	4 P	top or bottom	2698 4200
4000 ... 5000 / B9	4000 / B9	3/4 P	top or bottom	1509 4200



aces_079 eps

For 6/8-pole SIRCO

Rating (A) / Frame size	No. of poles	Position	Reference
125 ... 160 / B3 _{DS}	6 P	Top or bottom	1509 3012
125 ... 160 / B3 _{DS}	8 P	Top or bottom	1509 4012
250 / B4 _{DS}	6 P	Top or bottom	1509 3025
250 / B4 _{DS}	8 P	Top or bottom	1509 4025
400 ... 630 / B5 _{DS}	6 P	Top or bottom	1509 3063
400 ... 630 / B5 _{DS}	8 P	Top or bottom	1509 4063
800 ... 1250 / B6 _{DS} -B7 _{DS}	6 P	Top or bottom	1509 3080
800 ... 1250 / B6 _{DS} -B7 _{DS}	8 P	Top or bottom	1509 4080
1600 / B7 _{DS}	6 P	Top or bottom	1509 3160
1600 / B7 _{DS}	8 P	Top or bottom	1509 4160

Cage terminals

Use

They enable a direct terminal-free connection to rigid copper and aluminium conductors with integration under the IP2X protective cover.

Material: tin-plated aluminium

Dimensions

Rating (A) / Frame size	A	A1	C	R	ØX	X1	Z
125 ... 160 / B3	47.5	22.5	25	20	8.5	M12	10
200 ... 250 / B4	62	31.5	31.5	25	10.5	M16	14
315 ... 400 / B5	71.5	32	38	32	10.5	M20	15
500 ... 630 / B5	76.5	37	38	40	12.5	M20	15

References

Rating (A) / Frame size	Tightening capacity (mm ²)	No. of poles	Tightening torque (Nm)	Flexible bar width (mm)	Reference
125 ... 160 / B3	16 ... 95	3 P	14	13	5400 3016
125 ... 160 / B3	16 ... 95	4 P	14	13	5400 4016
200 ... 250 / B4	16 ... 185	3 P	25	18	5400 3025
200 ... 250 / B4	16 ... 185	4 P	25	18	5400 4025
315 ... 400 / B5	50 ... 240	3 P	45	20	5400 3040
315 ... 400 / B5	50 ... 240	4 P	45	20	5400 4040
500 ... 630 / B5	70 ... 300	3 P	45	24	5400 3063
500 ... 630 / B5	70 ... 300	4 P	45	24	5400 4063

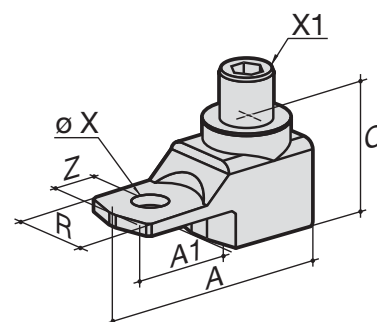

born_019_a1_x_cat

Accessories (continued)

Copper bar connection kits

Use

To allow connection between the two power terminals of the same pole for 2000 to 3200 A ratings (Fig. 1 and Fig 2).

For 3200 A rating, the connection pieces (part A) are delivered bridged as standard.

Bolt sets must be ordered separately.

Further details for these specific accessories are available in the user guide downloadable from www.socomec.com.

Top or bottom flat connection - Fig. 1

Rating (A) / Frame size	Part	Quantity to order per pole ⁽¹⁾	Reference
2000 ... 2500 / B8	Connection - part A	1	2619 1200
2000 ... 2500 / B8	Bolt set - part B	1	2699 1200
3200 / B8	Connection - part A		included
3200 / B8	Bolt set - part B	1	2699 1200
4000 ... 5000 / B9	Standard connection		

(1) Example for 3-pole device equipped top only; order 3 times the indicated quantity.

Fig. 1

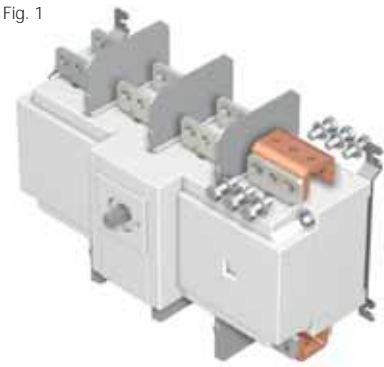

access_220.eps

Fig. 1

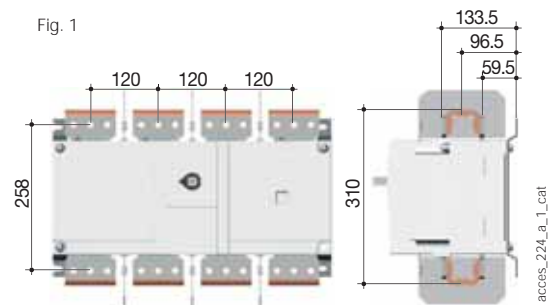

access_224_a_1_cat

Top or bottom edgewise connection - Fig. 2

Rating (A) / Frame size	Part	Quantity to order per pole ⁽¹⁾	Reference
2000 ... 2500 / B8	Connection - part A	1	2619 1200
2000 ... 2500 / B8	T piece - part C	1	2629 1200 ⁽²⁾
2000 ... 2500 / B8	Bracket - part D	1	2639 1200 ⁽²⁾
3200 / B8	Connection - part A		included
3200 / B8	T piece - part C	1	2629 1200
3200 / B8	Bracket - part D	1	2639 1200
4000 ... 5000 / B9	Standard connection		

(1) Example for 3-pole device equipped top only; order 3 times the indicated quantity.
(2) Bolt set is provided with the accessories.

Fig. 2



access_222.eps

Fig. 2

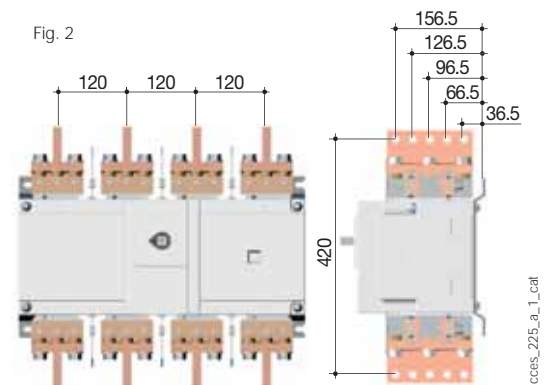

access_225_a_1_cat

Key handle interlocking system

Use

Locking in position 0 of the front or side operation handle:

- using a padlock (not supplied) and standard padlocking function of the handle. From 125 to 1800 A, padlocking the external front operation handle provides door interlocking,

- using a lock (not supplied): see diagrams opposite,
- using an undervoltage coil: the SIRCO can only be closed if the coil is energised.

For 6 / 8-pole, please consult us.

For SIRCO

Locking using RONIS EL11AP lock (not supplied)

Rating (A) / Frame size	No. of poles	Operation	Figure	Reference
125 ... 630 / B3 ... B5	3/4 P	Front direct	1	2699 6008 ⁽¹⁾
125 ... 1800 / B3 ... B7	3/4 P	External front	3	1499 7701
800 ... 3200 / B6 ... B8	3/4 P	Front direct	2	2699 6027
1250 ... 5000 / B7 ... B9	3/4 P	External front	4	2799 7002

(1) Front operation handle included.

For SIRCO AC

Locking using RONIS EL11AP lock (not supplied)

Rating (A) / Frame size	No. of poles	Operation	Figure	Reference
200 ... CD 630 / B4 ... B5	3/4 P	Front direct	1	2699 6008 ⁽¹⁾
630 ... 1600 / B6 ... B7	3/4 P	Front direct	2	2699 6027

(1) The locking system is directly mounted on the device.

For SIRCO

Locking using 230 VAC undervoltage coil

(For other voltages, please contact us)

Rating (A) / Frame size	No. of poles	Operation	Reference
125 ... 630 / B3 ... B5	3/4 P	External front	2699 9063 ⁽¹⁾
800 ... 3200 / B6 ... B8	3/4 P	Front direct	2699 9315 ⁽¹⁾

(1) The locking system is directly mounted on the device.

Locking using CASTELL lock (not supplied)

Rating (A) / Frame size	No. of poles	Handle type	Lock type	Operation	Figure	Reference
125 ... 160 / B3	6/8 P	S2	K	External front	2	4109 8507
125 ... 1 800 / B3 ... B8	3/4 P	S2, S4	FS	External front	3	1499 7703
125 ... 1 800 / B3 ... B8	3/4 P	S2, S4	K	External front	3	1499 7702
250 ... 630 / B4 ... B5	6/8 P	S4	K	External front	2	2999 8707
800 ... 1 600 / B6 ... B7	6/8 P	S5	K	External front	2	2799 7003
1 250 ... 4 000 / B7 ... B9	3/4 P	S5, S0	K	External front	2	2799 7003

Fig. 1

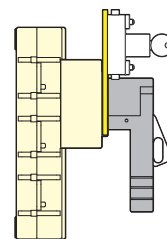

Fig. 3

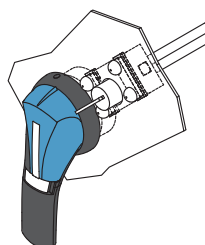

Fig. 2

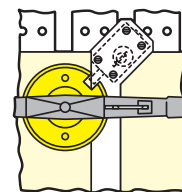
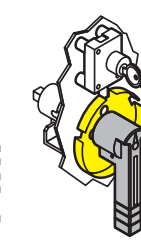

Fig. 4



Other specific accessories



- Mechanical coupling device for making switches with "n" poles of the same or different ratings
- Mechanical interlocking device

SIRCO characteristics according to IEC 60947-3

125 to 800 A

Thermal current I_{th} at 40°C	125 A	160 A	200 A	250 A	315 A	400 A	500 A	630 A	800 A
Frame size	B3	B3	B4	B4	B5	B5	B5	B5	B6
Rated insulation voltage U_i (V)	800	800	800	800	1000	1000	1000	1000	1000
Rated impulse withstand voltage U_{imp} (kV)	8	8	8	8	12	12	12	12	12

Rated operational currents I_e (A)

Rated voltage	Utilisation category	A / B ⁽¹⁾	A / B ⁽¹⁾	A / B ⁽¹⁾	A / B ⁽¹⁾	A / B ⁽¹⁾	A / B ⁽¹⁾	A / B ⁽¹⁾	A / B ⁽¹⁾	A / B ⁽¹⁾
415 VAC	AC-20 A / AC-20 B	125 / 125	160 / 160	200 / 200	250 / 250	315 / 315	400 / 400	500 / 500	630 / 630	800 / 800
415 VAC	AC-21 A / AC-21 B	125 / 125	160 / 160	200 / 200	250 / 250	315 / 315	400 / 400	500 / 500	630 / 630	800 / 800
415 VAC	AC-22 A / AC-22 B	125 / 125	160 / 160	200 / 200	250 / 250	315 / 315	400 / 400	500 / 500	630 / 630	800 / 800
415 VAC	AC-23 A / AC-23 B	125 / 125	160 / 160	200 / 200	250 / 250	315 / 315	400 / 400	500 / 500	500 / 500	800 / 800
220 VDC	DC-20 A / DC-20 B	125 / 125	160 / 160	200 / 200	250 / 250	315 / 315	400 / 400	500 / 500	630 / 630	800 / 800
220 VDC	DC-21 A / DC-21 B	125 / 125	160 / 160	160 / 200	250 / 250	315 / 315	400 / 400	500 / 500	630 / 630	800 / 800
220 VDC	DC-22 A / DC-22 B	125 / 125	160 / 160	160 / 200	250 / 250	315 / 315	400 / 400	400 / 500	500 / 500	800 / 800
220 VDC	DC-23 A / DC-23 B	125 / 125	125 / 125	160 / 160	200 / 200	315 / 315	400 / 400	400 / 400	500 / 500	800 / 800
440 VDC	DC-20 A / DC-20 B	125 / 125	160 / 160	200 / 200	250 / 250	315 / 315	400 / 400	500 / 500	630 / 630	800 / 800
440 VDC	DC-21 A / DC-21 B	125 ⁽²⁾ / 125 ⁽²⁾	160 ⁽²⁾ / 160 ⁽²⁾	160 ⁽²⁾ / 200 ⁽²⁾	200 ⁽²⁾ / 200 ⁽²⁾	315 ⁽²⁾ / 315 ⁽²⁾	400 ⁽²⁾ / 400 ⁽²⁾	400 ⁽²⁾ / 400 ⁽²⁾	500 ⁽²⁾ / 500 ⁽²⁾	800 ⁽³⁾ / 800 ⁽³⁾
440 VDC	DC-22 A / DC-22 B	125 ⁽²⁾ / 125 ⁽²⁾	125 ⁽²⁾ / 125 ⁽²⁾	160 ⁽²⁾ / 160 ⁽²⁾	200 ⁽²⁾ / 200 ⁽²⁾	315 ⁽²⁾ / 315 ⁽²⁾	400 ⁽²⁾ / 400 ⁽²⁾	400 ⁽²⁾ / 400 ⁽²⁾	500 ⁽²⁾ / 500 ⁽²⁾	800 ⁽³⁾ / 800 ⁽³⁾
440 VDC	DC-23 A / DC-23 B	125 ⁽³⁾ / 125 ⁽³⁾	125 ⁽³⁾ / 125 ⁽³⁾	160 ⁽³⁾ / 160 ⁽³⁾	200 ⁽³⁾ / 200 ⁽³⁾	315 ⁽³⁾ / 315 ⁽³⁾	400 ⁽³⁾ / 400 ⁽³⁾	400 ⁽³⁾ / 400 ⁽³⁾	500 / 500	800 ⁽³⁾ / 800 ⁽³⁾
500 VDC	DC-20 A / DC-20 B	125 / 125	160 / 160	200 / 200	250 / 250	315 / 315	400 / 400	500 / 500	630 / 630	800 / 800
500 VDC	DC-21 A / DC-21 B	125 ⁽²⁾ / 125 ⁽²⁾	125 ⁽²⁾ / 125 ⁽²⁾	160 ⁽²⁾ / 200 ⁽²⁾	200 ⁽²⁾ / 200 ⁽²⁾	315 ⁽²⁾ / 315 ⁽²⁾	400 ⁽²⁾ / 400 ⁽²⁾	400 ⁽²⁾ / 400 ⁽²⁾	500 ⁽²⁾ / 500 ⁽²⁾	800 ⁽³⁾ / 800 ⁽³⁾
500 VDC	DC-22 A / DC-22 B	125 ⁽³⁾ / 125 ⁽³⁾	125 ⁽³⁾ / 125 ⁽³⁾	160 ⁽³⁾ / 160 ⁽³⁾	200 ⁽³⁾ / 200 ⁽³⁾	315 ⁽³⁾ / 315 ⁽³⁾	315 ⁽³⁾ / 400 ⁽³⁾	315 ⁽³⁾ / 400 ⁽³⁾	500 ⁽³⁾ / 500 ⁽³⁾	800 ⁽³⁾ / 800 ⁽³⁾
500 VDC	DC-23 A / DC-23 B	125 ⁽³⁾ / 125 ⁽³⁾	125 ⁽³⁾ / 125 ⁽³⁾	160 ⁽³⁾ / 160 ⁽³⁾	200 ⁽³⁾ / 200 ⁽³⁾	315 ⁽³⁾ / 315 ⁽³⁾	315 ⁽³⁾ / 400 ⁽³⁾	315 ⁽³⁾ / 400 ⁽³⁾	500 ⁽³⁾ / 500 ⁽³⁾	800 ⁽³⁾ / 800 ⁽³⁾

Operational power in AC-23 (kW)⁽¹⁾⁽⁴⁾

At 415 VAC without AC pre-break ⁽¹⁾	63 / 63	80 / 80	100 / 100	132 / 132	160 / 160	220 / 220	280 / 280	280 / 280	450 / 450
--	---------	---------	-----------	-----------	-----------	-----------	-----------	-----------	-----------

Reactive power (kvar)

At 400 VAC (kvar) ⁽⁴⁾	55	75	90	115	145	185	230	290	365
----------------------------------	----	----	----	-----	-----	-----	-----	-----	-----

gG DIN fuse protected short-circuit withstand (kA rms prospective)⁽⁵⁾

Prospective short-circuit current (kA rms)	100	100	80	50	100	100	100	70	50
Associated fuse rating (A)	125	160	200	250	315	400	500	630	800

Circuit breaker protected short-circuit withstand with any circuit breaker that ensures tripping in less than 0.3s

Rated short-time withstand current 0.3s. I_{cw} (kA rms)	15	15	17	17	25	25	25	25	50
--	----	----	----	----	----	----	----	----	----

Short-circuit operation (switch only)

Rated short-time withstand current I_{cw} 1s (kA rms)	7	7	9	9	13	13	13	13	26
Rated peak withstand current in I_{cc} (kA peak) ⁽⁵⁾⁽⁶⁾	20	20	30	30	45	45	45	45	55

Connection

Minimum Cu cable cross-section (mm ²)	35	50	70	95	150	185	240	2 x 150	2 x 185
Minimum Cu busbar cross-section (mm ²)								2 x 30 x 5	2 x 40 x 5
Maximum Cu cable cross-section (mm ²)	50	95	95	150	240	240	240	2 x 300	2 x 300
Maximum Cu busbar width (mm)	25	25	32	32	40	40	40	50	63
Tightening torque min/max (Nm)	9 / -	9 / -	20 / -	20 / -	20 / -	20 / -	20 / -	40 / 45	40 / 45

Mechanical characteristics

Durability (number of operating cycles)	10000	10000	10000	10000	10000	10000	10000	10000	3000
Operating effort (Nm)	6.5	6.5	10	10	14.5	14.5	14.5	14.5	37
Weight of a 3-pole device (kg)	1	1.5	2	2	3.5	3.5	3.5	3.5	8
Weight of a 4-pole device (kg)	1.5	1.5	2	2	4	4	4.5	4.5	10

(1) Category with index A = frequent operation - Category with index B = infrequent operation.

(2) 3-pole device with 2 poles in series for the '+' and 1 pole for the '-'.

(3) 4-pole device with 2 poles in series per polarity.

(4) The power value is given for information only, the current values vary from one manufacturer to another.

(5) For a rated operational voltage $U_e = 415$ VAC.

(6) Coordination tables with circuit breaker: please consult us.

SIRCO characteristics according to IEC 60947-3

1000 to 5000 A

Thermal current I_{th} at 40°C	1000 A	CD 1250 A	1250 A	1600 A	1800 A	2000 A	2500 A	3200 A	4000 A	5000 A
Frame size	B6	B6	B7	B7	B7	B8	B8	B8	B9	B9
Rated insulation voltage U_i (V)	1000	1000	1000	1000	1000	1000	1000	1000	1000	1000
Rated impulse withstand voltage U_{imp} (kV)	12	12	12	12	12	12	12	12	12	12

Rated operational currents I_e (A)

Rated voltage	Utilisation category	A/B ⁽¹⁾	A/B ⁽¹⁾	A/B ⁽¹⁾	A/B ⁽¹⁾	A/B ⁽¹⁾	A/B ⁽¹⁾	A/B ⁽¹⁾	A/B ⁽¹⁾	A/B ⁽¹⁾	A/B ⁽¹⁾
415 VAC	AC-20 A / AC-20 B	1000 / 1000	1250 / 1250	1250 / 1250	1600 / 1600	1800 / 1800	2000 / 2000	2500 / 2500	3200 / 3200	4000 / 4000	5000 / 5000
415 VAC	AC-21 A / AC-21 B	1000 / 1000	1250 / 1250	1250 / 1250	1600 / 1600	1800 / 1800	2000 / 2000	2500 / 2500	3200 / 3200	4000 / 4000	5000 / 5000
415 VAC	AC-22 A / AC-22 B	1000 / 1000	1250 / 1250	1250 / 1250	1600 / 1600	1800 / 1800	2000 / 2000	2500 / 2500	2500 / 3200	2500 / 3200	2500 / 3200
415 VAC	AC-23 A / AC-23 B	1000 / 1000	1250 / 1250	1250 / 1250	1250 / 1250	1250 / 1250	1600 / 1600	1600 / 1600	1600 / 1600	1800 / 2000	1800 / 2000
220 VDC	DC-20 A / DC-20 B	1000 / 1000	1250 / 1250	1250 / 1250	1600 / 1600	1800 / 1800	2000 / 2000	2500 / 2500	3200 / 3200	4000 / 4000	5000 / 5000
220 VDC	DC-21 A / DC-21 B	1000 / 1000	1250 / 1250	1250 / 1250	1250 / 1600	1250 / 1600	2000 / 2000	2000 / 2500	2000 / 2500	2500 / 3200	2500 / 3200
220 VDC	DC-22 A / DC-22 B	1000 / 1000	1250 / 1250	1250 / 1250	1250 / 1250	1250 / 1250	1250 / 1600	1250 / 1600	1250 / 1600	1800 / 2000	1800 / 2000
220 VDC	DC-23 A / DC-23 B	1000 / 1000	1250 / 1250	1250 / 1250	1250 / 1250	1250 / 1250	1250 / 1250	1250 / 1250	1250 / 1250	1250 / 1600	1250 / 1600
440 VDC	DC-20 A / DC-20 B	1000 / 1000	1250 / 1250	1250 / 1250	1600 / 1600	1800 / 1800	2000 / 2000	2500 / 2500	3200 / 3200	4000 / 4000	5000 / 5000
440 VDC	DC-21 A / DC-21 B	1000 ⁽²⁾ / 1000 ⁽²⁾	1250 ⁽²⁾ / 1250 ⁽²⁾	1250 ⁽²⁾ / 1250 ⁽²⁾	1250 ⁽²⁾ / 1600 ⁽²⁾	1250 ⁽²⁾ / 1600 ⁽²⁾	2000 ⁽²⁾ / 2000 ⁽²⁾	2000 ⁽²⁾ / 2500 ⁽²⁾	2500 ⁽²⁾ / 3200 ⁽²⁾	3200 ⁽²⁾ / 4000 ⁽²⁾	3200 ⁽²⁾ / 5000 ⁽²⁾
440 VDC	DC-22 A / DC-22 B	1000 ⁽²⁾ / 1000 ⁽²⁾	1250 ⁽²⁾ / 1250 ⁽²⁾	1250 ⁽²⁾ / 1250 ⁽²⁾	1250 ⁽²⁾ / 1250 ⁽²⁾	1250 ⁽²⁾ / 1250 ⁽²⁾	1250 ⁽²⁾ / 1250 ⁽²⁾	1250 ⁽²⁾ / 1250 ⁽²⁾	1250 ⁽²⁾ / 1250 ⁽²⁾	1600 ⁽²⁾ / 1800 ⁽²⁾	1600 ⁽²⁾ / 1800 ⁽²⁾
440 VDC	DC-23 A / DC-23 B	1000 ⁽²⁾ / 1000 ⁽²⁾	1250 ⁽²⁾ / 1250 ⁽²⁾	1250 ⁽²⁾ / 1250 ⁽²⁾	1250 ⁽²⁾ / 1250 ⁽²⁾	1250 ⁽²⁾ / 1250 ⁽²⁾	1250 ⁽²⁾ / 1250 ⁽²⁾	1250 ⁽²⁾ / 1250 ⁽²⁾	1250 ⁽²⁾ / 1250 ⁽²⁾	1250 ⁽²⁾ / 1250 ⁽²⁾	1250 ⁽²⁾ / 1250 ⁽²⁾
500 VDC	DC-20 A / DC-20 B	1000 / 1000	1250 / 1250	1250 / 1250	1600 / 1600	1800 / 1800	2000 / 2000	2500 / 2500	3250 / 3250	4000 / 4000	5000 / 5000
500 VDC	DC-21 A / DC-21 B	1000 ⁽²⁾ / 1000 ⁽²⁾	1250 ⁽²⁾ / 1250 ⁽²⁾	1250 ⁽²⁾ / 1250 ⁽²⁾	1250 ⁽²⁾ / 1600 ⁽²⁾	1250 ⁽²⁾ / 1600 ⁽²⁾	1250 ⁽²⁾ / 1250 ⁽²⁾	1250 ⁽²⁾ / 1250 ⁽²⁾	1250 ⁽²⁾ / 1250 ⁽²⁾	1600 ⁽²⁾ / 1800 ⁽²⁾	1600 ⁽²⁾ / 1800 ⁽²⁾
500 VDC	DC-22 A / DC-22 B	1000 ⁽²⁾ / 1000 ⁽²⁾	1250 ⁽²⁾ / 1250 ⁽²⁾	1250 ⁽²⁾ / 1250 ⁽²⁾	1250 ⁽²⁾ / 1250 ⁽²⁾	1250 ⁽²⁾ / 1250 ⁽²⁾	1250 ⁽²⁾ / 1250 ⁽²⁾	1250 ⁽²⁾ / 1250 ⁽²⁾	1250 ⁽²⁾ / 1250 ⁽²⁾	1250 ⁽²⁾ / 1600 ⁽²⁾	1250 ⁽²⁾ / 1600 ⁽²⁾
500 VDC	DC-23 A / DC-23 B	1000 ⁽²⁾ / 1000 ⁽²⁾	1250 ⁽²⁾ / 1250 ⁽²⁾	1250 ⁽²⁾ / 1250 ⁽²⁾	1250 ⁽²⁾ / 1250 ⁽²⁾	1250 ⁽²⁾ / 1250 ⁽²⁾	1000 ⁽²⁾ / 1000 ⁽²⁾	1000 ⁽²⁾ / 1000 ⁽²⁾	1000 ⁽²⁾ / 1000 ⁽²⁾	1000 ⁽²⁾ / 1000 ⁽²⁾	1000 ⁽²⁾ / 1000 ⁽²⁾

Operational power in AC-23 (kW)⁽³⁾

At 415 VAC without AC pre-break ⁽¹⁾	560 / 560	710 / 710	710 / 710	710 / 710	710 / 710	710 / 710	710 / 710	710 / 710	710 / 710	710 / 710	710 / 710
--	-----------	-----------	-----------	-----------	-----------	-----------	-----------	-----------	-----------	-----------	-----------

Reactive power (kvar)

At 400 VAC (kvar) ⁽³⁾	460										
----------------------------------	-----	--	--	--	--	--	--	--	--	--	--

gG DIN fuse protected short-circuit withstand (kA rms prospective)⁽⁴⁾

Prospective short-circuit current (kA rms)	100	100	100	100	100	100	100				
Associated fuse rating (A)	1000	1250	1250	2 x 800	2 x 800	2 x 1000	2 x 1250				

Circuit breaker protected short-circuit withstand with any circuit breaker that ensures tripping in less than 0.3s

Rated short-time withstand current 0.3s. I_{cw} (kA rms)	65	65	100	100	100	100	100	100			
--	----	----	-----	-----	-----	-----	-----	-----	--	--	--

Short-circuit operation (switch only)

Rated short-time withstand current I_{cw} 1s (kA rms)	35	35	50	50	50	50	50	50	75	75
Rated peak withstand current in I_{cc} (kA peak) ⁽⁴⁾⁽⁵⁾	80	80	110	110	110	110	110	110	120	165

Connection

Minimum Cu cable cross-section (mm ²)	2 x 240										
Minimum Cu busbar cross-section (mm ²)	2 x 50 x 5	2 x 60 x 5	2 x 60 x 5	2 x 80 x 5	3 x 100 x 5	3 x 100 x 5	4 x 100 x 5	4 x 100 x 5	2 x 200 x 10	2 x 200 x 10	
Maximum Cu cable cross-section (mm ²)	4 x 185	4 x 185	4 x 185	6 x 185	6 x 185						
Maximum Cu busbar width (mm)	63	63	100	100	100	100	100	100			
Tightening torque min/max (Nm)	40/45	40/45	40/45	40/45	40/45	40/45	40/45	40/-	40/-	40/-	

Mechanical characteristics

Durability (number of operating cycles)	3000	3000	4000	4000	4000	3000	3000	3000	2000	2000
Operating effort (Nm)	37	37	56	56	56	75	75	75	105	105
Weight of a 3-pole device (kg)	8	8	12	12	12	22	22	22	45	45
Weight of a 4-pole device (kg)	10	10	15	15	15	25	25	25	50	50

(1) Category with index A = frequent operation - Category with index B = infrequent operation.

(2) 4-pole device with 2 poles in series per polarity.

(3) The power value is given for information only, the current values vary from one manufacturer to another.

(4) For a rated operational voltage $U_e = 415$ VAC.

(5) Coordination tables with circuit breaker: please consult us.

SIRCO AC characteristics according to IEC 60947-3

200 to 630 A

Thermal current I_{th} at 40°C	200 A	250 A	315 A	400 A	500 A	CD 630 A	630 A
Rated insulation voltage U_i (V)	1000	1000	1000	1000	1000	1000	1000
Rated impulse withstand voltage U_{imp} (kV)	12	12	12	12	12	12	12
Rated operational currents I_e (A)							
Rated voltage	Utilisation category	A/B ⁽¹⁾	A/B ⁽¹⁾	A/B ⁽¹⁾	A/B ⁽¹⁾	A/B ⁽¹⁾	A/B ⁽¹⁾
500 VAC	AC-20 A / AC-20 B	200/200	250/250	315/315	400/400	500/500	630/630
500 VAC	AC-21 A / AC-21 B	200/200	250/250	315/315	400/400	500/500	630/630
500 VAC	AC-22 A / AC-22 B	200/200	250/250	315/315	400/400	500/500	630/630
500 VAC	AC-23 A / AC-23 B	200/200	250/250	315/315	400/400	500/500	630/630
690 VAC	AC-20 A / AC-20 B	200/200	250/250	315/315	400/400	500/500	630/630
690 VAC	AC-21 A / AC-21 B	200/200	250/250	315/315	400 ⁽²⁾ /400 ⁽²⁾	500 ⁽²⁾ /500 ⁽²⁾	630 ⁽²⁾ /630 ⁽²⁾
690 VAC	AC-22 A / AC-22 B	200/200	250/250	315/315	400 ⁽²⁾ /400 ⁽²⁾	500 ⁽²⁾ /500 ⁽²⁾	630 ⁽²⁾ /630 ⁽²⁾
690 VAC	AC-23 A / AC-23 B	200/200	250/250	315/315	400 ⁽²⁾ /400 ⁽²⁾	500 ⁽²⁾ /500 ⁽²⁾	630 ⁽²⁾ /630 ⁽²⁾
Operational power in AC-23 A (kW) ⁽³⁾							
At 690 VAC without pre-break AC	160	220	250	400	500	500	630
Reactive power (kvar)							
At 690 VAC (kvar)	160	190	250	325	400	400	450
Fuse protected short-circuit withstand (kA rms prospective) at 690 VAC ⁽⁴⁾							
Prospective short-circuit current (kA rms)	50	50	50	50	50	50	50
Associated fuse rating (A)	200	250	315	400	500	630	630
Circuit breaker protected short-circuit withstand with any circuit breaker that ensures tripping in less than 0.3s at 690 VAC							
Rated short-time withstand current 0.3s. I_{cw} (kA rms)	15	15	15	15	15	15	28
Short-circuit capacity (without protection)							
Rated short-time withstand current 1s. I_{cw} (kA rms)	8	8	8	11	11	11	20
Rated short-circuit making capacity without fuses I_{cm} (prospective kA peak)	22	22	22	22	22	22	40
Connection							
Minimum Cu cable cross-section (mm ²)	70	70	70	185	240	2 x 150	2 x 185
Minimum Cu busbar cross-section (mm ²)						2 x 30 x 5	2 x 40 x 5
Maximum Cu cable cross-section (mm ²)	95	95	95	240	240	2 x 300	2 x 300
Maximum Cu busbar width (mm)	32	32	32	40	40	63	63
Tightening torque min/max (Nm)	20/-	20/-	20/-	20/-	20/-	20/-	40/45
Mechanical characteristics							
Durability (number of operating cycles)	10000	10000	10000	5000	5000	5000	4000
Operating effort (Nm)	10	10	10	14.5	14.5	14.5	48
Weight of a 3 pole device (kg)	2	2	2	3.5	3.5	3.5	8
Weight of a 4 pole device (kg)	2	2	2	4	4	4	10

(1) Category with index A = frequent operation - Category with index B = infrequent operation.

(2) With terminal shrouds or phase barrier.

(3) The power value is given for information only, the current values vary from one manufacturer to another.

(4) For a rated operational voltage $U_n = 690$ VAC.

SIRCO AC characteristics according to IEC 60947-3

800 to 4000 A

Thermal current I_{th} at 40°C	800 A	1000A	CD 1250 A	1250 A	1600 A	2000 A	4000 A
Rated insulation voltage U_i (V)	1000	1000	1000	1000	1000	1000	1000
Rated impulse withstand voltage U_{imp} (kV)	12	12	12	12	12	12	12
Rated operational currents I_e (A)							
Rated voltage	Utilisation category	A/B ⁽¹⁾	A/B ⁽¹⁾	A/B ⁽¹⁾	A/B ⁽¹⁾	A/B ⁽¹⁾	A/B ⁽¹⁾
500 VAC	AC-20 A / AC-20 B	800/800	1000/1000	1250/1250	1250/1250	1600/1600	2000/2000
500 VAC	AC-21 A / AC-21 B	800/800	1000/1000	1250/1250	1250/1250	1600/1600	2000/2000
500 VAC	AC-22 A / AC-22 B	800/800	1000/1000	1250/1250	1250/1250	1600/1600	2000/2000
500 VAC	AC-23 A / AC-23 B	800/800	1000/1000	1250/1250	1250/1250	1600/1600	2000/2000
690 VAC	AC-20 A / AC-20 B	800/800	1000/1000	1250/1250	1250/1250	1600/1600	2000/2000
690 VAC	AC-21 A / AC-21 B	800/800	1000/1000	1250/1250	1250/1250	1600/1600	2000/2000
690 VAC	AC-22 A / AC-22 B	800/800	1000/1000	1250/1250	1250/1250	1600/1600	2000/2000
690 VAC	AC-23 A / AC-23 B	800/800	1000/1000	1250/1250	1250/1250	1600/1600	2000/2000
Operational power in AC-23 A (kW) ⁽³⁾							
At 690 VAC without pre-break AC	900	900	-	-	-	-	-
Reactive power (kvar)							
At 690 VAC (kvar)	550	750	950	950	-	-	-
Fuse protected short-circuit withstand (kA rms prospective) at 690 VAC ⁽⁴⁾							
Prospective short-circuit current (kA rms)	50	50	50	50	50	-	-
Associated fuse rating (A)	800	800	2 x 500	1250	2 x 800	-	-
Circuit breaker protected short-circuit withstand with any circuit breaker that ensures tripping in less than 0.3s at 690 VAC							
Rated short-time withstand current 0.3s. I_{cw} (kA rms)	28	55	55	53	53	53	53
Short-circuit capacity (without protection) at 690 VDC							
Rated short-time withstand current 1s. I_{cw} (kA rms)	20	30	30	35	35	35	35
Rated short-circuit making capacity without fuses I_{cm} (prospective kA peak)	40	80	80	75	75	75	75
Connection							
Minimum Cu cable cross-section (mm ²)	2 x 185	2 x 240					
Minimum Cu busbar cross-section (mm ²)	2 x 40 x 5	2 x 50 x 5	2 x 60 x 5	2 x 60 x 5	2 x 80 x 5	3 x 100 x 5	1 x 100 x 5
Maximum Cu cable cross-section (mm ²)	2 x 300	4 x 185	4 x 185	4 x 185	6 x 185		
Maximum Cu busbar width (mm)	63	63	63	100	100	100	
Tightening torque min/max (Nm)	40/45	40/45	40/45	40	40	40	40
Mechanical characteristics							
Durability (number of operating cycles)	4000	4000	3000	4000	4000	3000	2000
Operating effort (Nm)	48	48	48	55	55	75	100
Weight of a 3 pole device (kg)	8	8	8	12	12	22	45
Weight of a 4 pole device (kg)	10	10	10	15	15	25	50

(1) Category with index A = frequent operation - Category with index B = infrequent operation.

(2) With terminal shrouds or phase barrier.

(3) The power value is given for information only, the current values vary from one manufacturer to another.

(4) For a rated operational voltage $U_e = 690$ VAC.

SIRCO

Load break switches for power distribution
from 125 to 5000 A

Dimensions - Front operation

SIRCO 125 to 630 A and SIRCO AC 200 to CD 630 A - B3 to B5

Direct front operation

External front operation

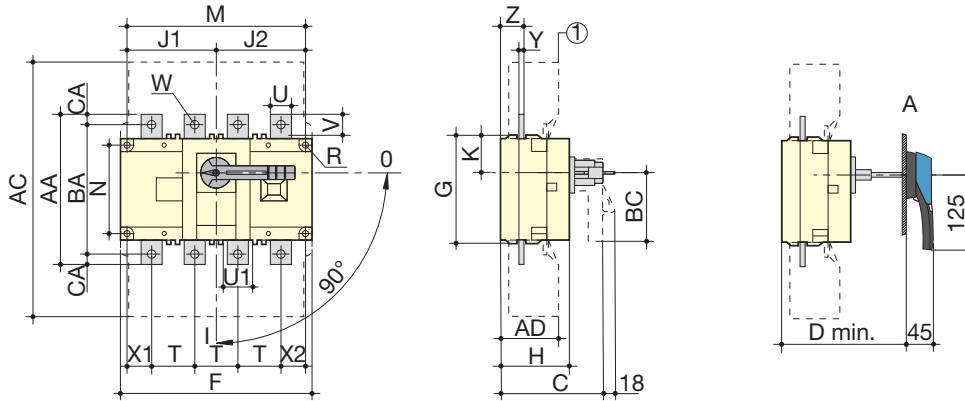

1. Terminal shrouds

A. S2 type handle

sirco_198_L1_x_cat

Rating (A) / Frame size		Overall dimensions		Terminal shrouds		Switch body						Switch mounting				Connection																		
SIRCO	SIRCO AC	C	D min	AC	AD	F 3p.	F 4p.	G	H	J1 3p.	J1 4p.	J2	K	BC	M 3p.	M 4p.	N	R	T	U	U1	V	W	X1 3p.	X1 4p.	X2	Y	Z	AA	BA	CA			
125...160/ B3		115	125	235	50	140	170	93	65	45	75	75	31.5	80	120	150	65	5.5	36	20	20.5	25	9	28	22	20	3.5	20.5	135	115	10			
200...250 / B4	200...250 / B4			280	60	180	230	108	75	55	105	105	34	115	160	210	80	5.5	50		25	25.5	21.5	11	33	33	27	3.5	22.5	170	130	15		
315...400/ B5	400...500 / B5	160	165	401	89	230	290	170	110	75	135	135	55	115	210	270	140	7	65		32	45.5	29											
500 / B5	-																								11									
630 / B5	CD 630 / B5																																	
					</																													

SIRCO 2000 to 3200 A and SIRCO AC 2000 A - B8

Direct front operation

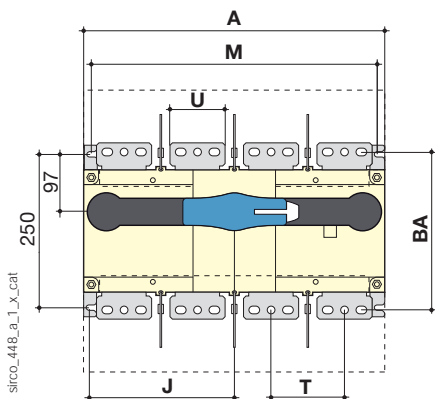

sirco_448_a_1_x_cat

External front operation

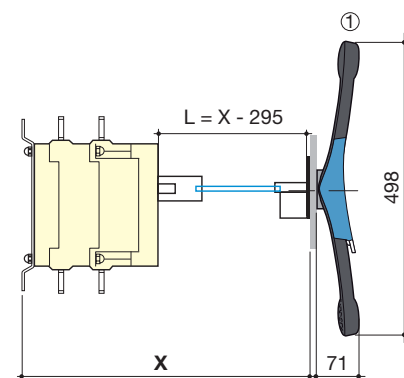

1. Double lever S5 type handle

Rating (A) / Frame size		Overall dimensions		Switch body		Switch mounting		Connection			
SIRCO	SIRCO AC	A 3p.	A 4p.	J 3p.	J 4p.	M 3p.	M 4p.	T	U	Y	BA
2000 ... 3200 / B8	2000 / B8	372	492	173.5	233.5	347	367	120	90	8	258

SIRCO 4000 to 5000 A and SIRCO AC 4000 A - B9

Direct front operation

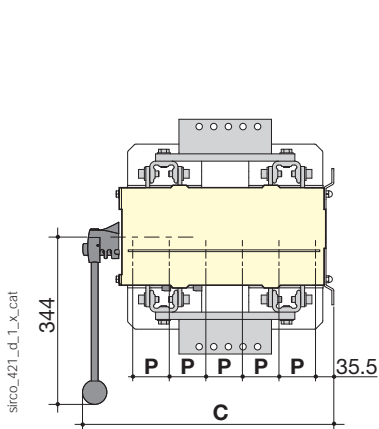

sirco_421_d_1_x_cat

External front operation

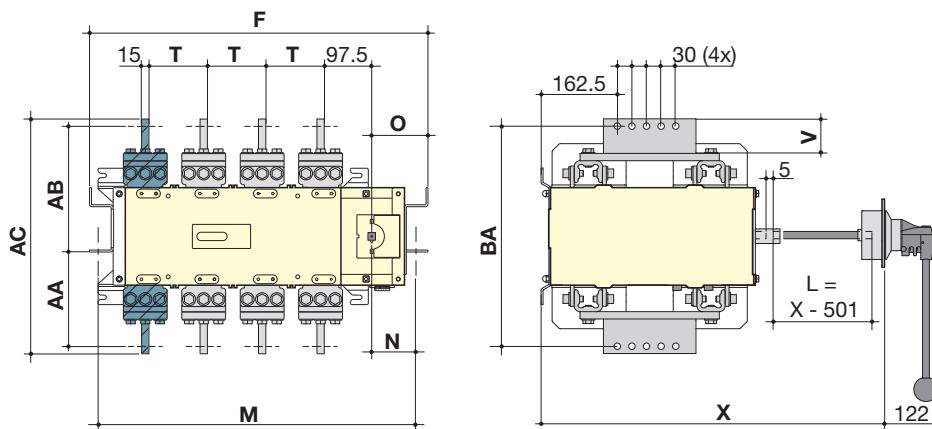

Rating (A) / Frame size		Overall dimensions	Switch body		Switch mounting					Connection					
SIRCO	SIRCO AC	C	F 3p.	F 4p.	M 3p.	M 4p.	N	O	P	T	V	AA	AB	AC	BA
4000 ... 5000 / B9	4000 / B9	514	695	695	660	660	98	115.5	75	120	86	160	292	482	452

SIRCO

Load break switches for power distribution
from 125 to 5000 A

Dimensions for external handles

B3 to B5

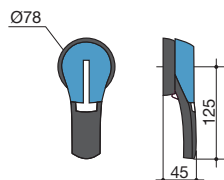
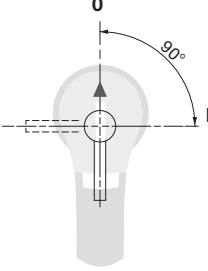
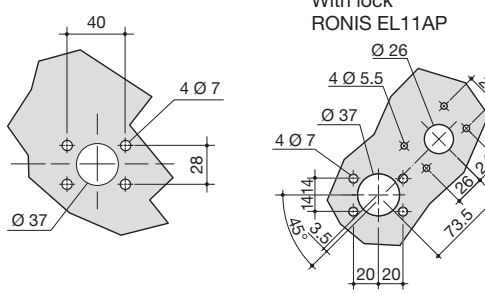
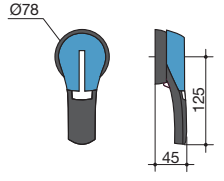
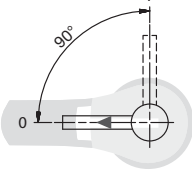
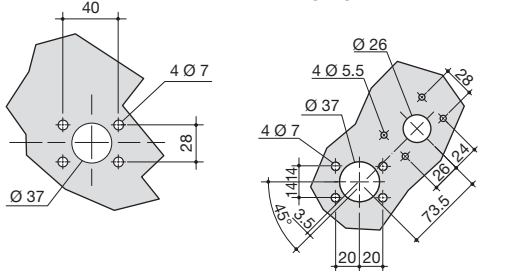
Handle type	Front operation Direction of operation	Door drilling
S2 type 		
S2 type 	Side operation Right side operation 	

B6 - B7

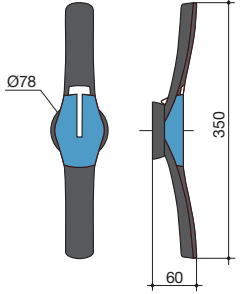
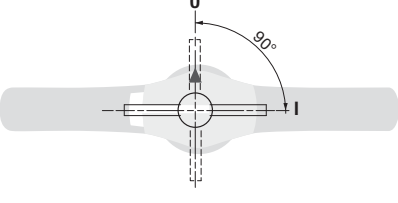
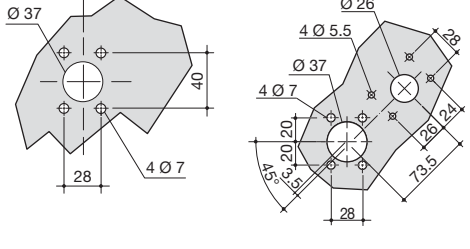
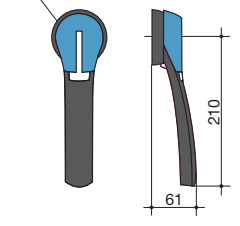
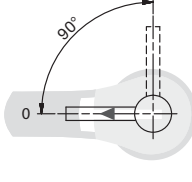
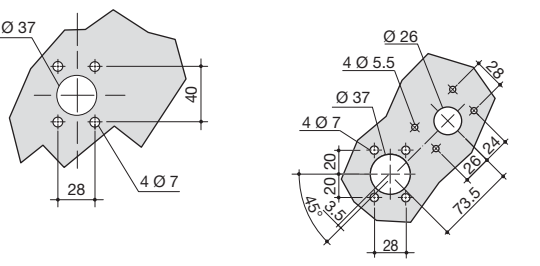
Handle type	Front operation Direction of operation	Door drilling
S4 type 		
S3 type 	Side operation Right side operation 	

B7 - B8

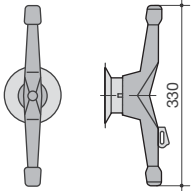
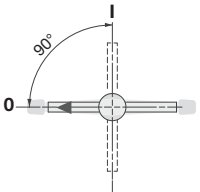
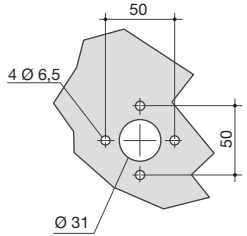
Handle type	Front operation Direction of operation	Door drilling
<p>V2 Type</p>  <p>poign_065_a_1_gb_cat</p>		

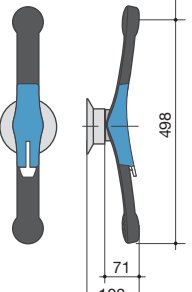
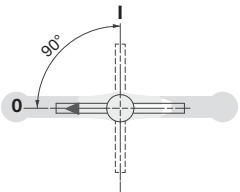
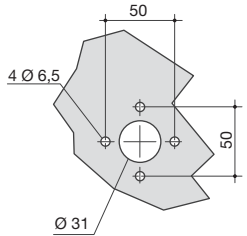
Handle type	Front operation Direction of operation	Door drilling
<p>S5 type with V Escutcheon</p>  <p>poign_020_a_1_gb_cat</p>		

B9

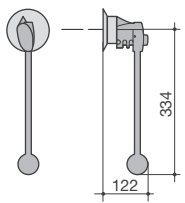
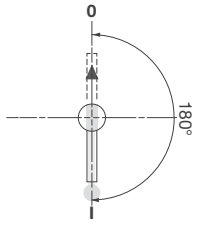
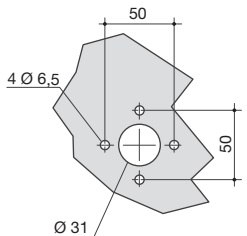
Handle type	Front operation Direction of operation	Door drilling
<p>V0 type</p>  <p>poign_009_a_1_gb_cat</p>		

SIRCO

Load break switches for power distribution
from 125 to 5000 A

Connection terminal

SIRCO 125 to 630 A and SIRCO AC 200 to CD 630 A

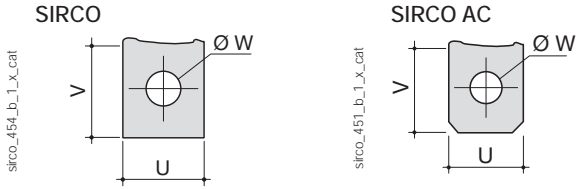

Rating (A)				
SIRCO	SIRCO AC	U	V	W
125 ... 160		20	25	9
200 ... 250	200 ... 250	25	21.5	11
	315	35		
315 ... 400	400 ... 500	32	29	13
500		45	41.5	
630	CD 630			

SIRCO 800 to 1000 A and SIRCO AC 630 to 1000 A

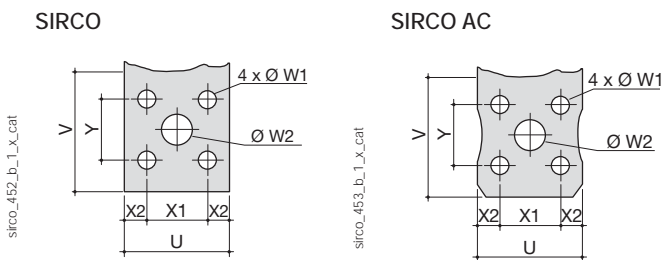

Rating (A)								
SIRCO	SIRCO AC	U	V	W1	W2	X1	X2	Y
800 ... 1000	630 ... 1000	50	60.5	9	15	33	8.5	33

SIRCO and SIRCO AC CD 1250 A

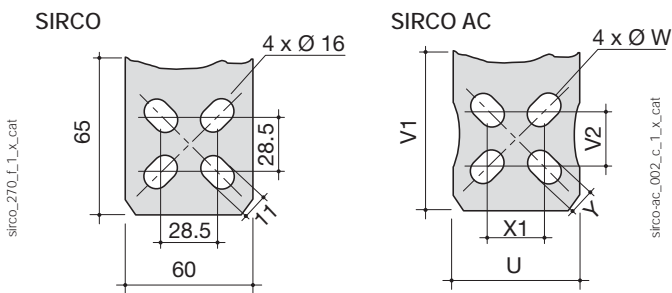

Rating (A)							
SIRCO	SIRCO AC	U	V1	V2	W	X1	Y
CD 1250 A	CD 1250 A	60	65	28.5	16	28.5	11

SIRCO 1250 to 3200 A and SIRCO AC 1250 to 1600 A

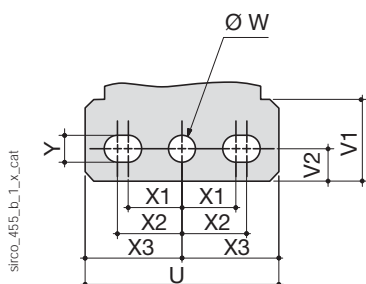

Rating (A)		U	V1	V2	W	X1	X2	X3	Y
SIRCO	SIRCO AC	90	35.8	15	12.5	25	30	45	12.5
1250 ... 3200	1250 ... 1600								

SIRCO 4000 to 5000 A and SIRCO AC 4000 A

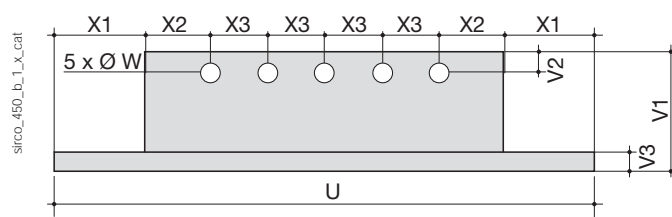

Rating (A)		U	W	X1	X2	X3	V1	V2	V3
SIRCO	SIRCO AC	286	13	48	35	30	86	15	15
4000 ... 5000	4000								

SIRCO MC PV IEC 60947-3

Load break switches for photovoltaic applications
from 25 to 40 A, up to 1000 VDC



SIRCO MC PV 25 A - 1000 VDC
DIN-rail mounting



SIRCO MC PV 25 A - 1000 VDC
Door mounting

The solution for

- > Residential buildings
- > Buildings
- > Solar parks



Strong points

- > Compact
- > High breaking capacity up to 1000 VDC
- > Safety
- > Easy assembling

Check it out

- > Need an enclosed switch? No problem with our specific product department. We have solutions for any requirement.



Function

SIRCO MC PV are DC load break switches. They make and break under load conditions and provide optimum safety isolation for any PV circuit.

Advantages

Compact

Thanks to its compact design, the space needed within the combiner box or the solar inverter is greatly reduced.

High breaking capacity up to 1000 VDC

- Making and breaking capacity under load conditions up to 1000 VDC.
- Specific photovoltaic test beyond requirements of IEC 60947-3 standard.

Safety

- Bridging bars are factory fitted for easier, quicker and safer connection.
- Direct access to connection terminals for adequate tightening.

Easy mounting

Three mounting possibilities are available for optimum integration and time saving:

- DIN-rail or back plate mounting.
- Door mounting.
- "Quick Fix" mounting (quarter turn fixation without tools).



SIRCO MC PV
DIN-rail mounting



SIRCO MC PV
Door mounted

Conformity to standards

- > IEC 60947-3
- > UL508i⁽¹⁾



(1) See UL version

Approvals and certifications⁽¹⁾



(1) Product reference on request.

Multi-circuit switching

- The SIRCO MC PV for dual circuits (2 MPPT: Maximum Power Point Tracking) enables connection of two independent photovoltaic circuits to a single switch in order to reduce the costs of the global solution.

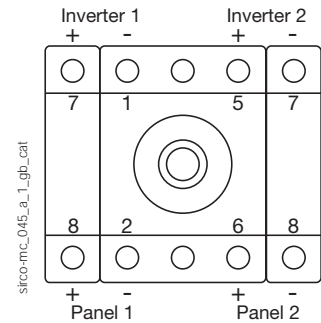
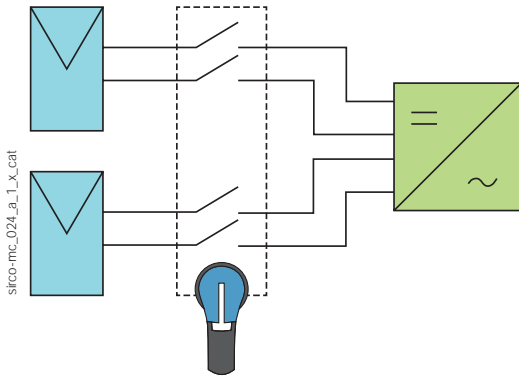

Completely isolate the inverter within one operation

- The SIRCO MC PV with two additional AC poles can be integrated into the inverter to provide complete and simultaneous isolation of the PV and AC circuits. This improves safety and reduces the overall product size.

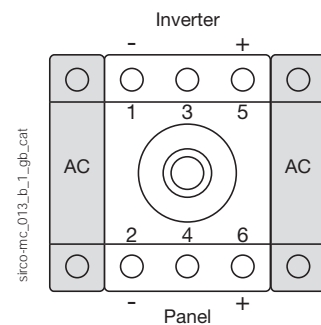
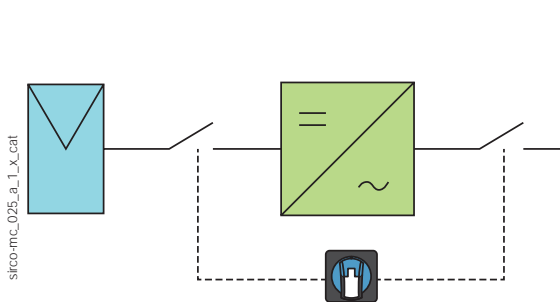

What you need to know

For grounded or ungrounded networks:

It is possible to use the SIRCO MC PV in both network systems, either switching one or both polarities.

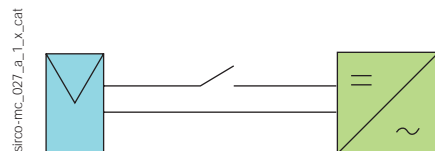
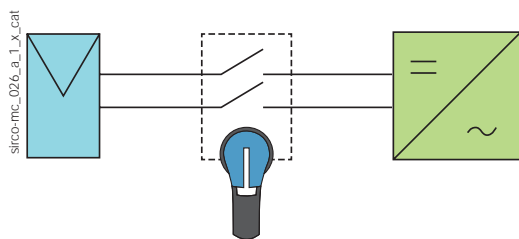

SIRCO MC PV IEC 60947-3

Load break switches for photovoltaic applications
from 25 to 40 A, up to 1000 VDC

References

600 VDC - DIN rail or back plate mounting

Rating (A)	Circuit type	Number of poles by PV polarity ⁽³⁾	No of poles AC current	Switch body	Direct handle ⁽¹⁾	External handle	Shaft for external handle	Auxiliary contact
30 A	Single PV circuit	1 P+, 1 P-	-	21PV 2102	MC0 type Blue 2119 0012 ⁽²⁾	MC1 type Black IP65 2119 3312 ⁽²⁾ Red / Yellow IP65 2119 3313	165 ... 200 mm 2107 0516	1 contact NC+NO 2119 0001
	PV + AC circuit	1 P+, 1P-	2 P	21PV 2162				
	Dual PV circuit	2 x (1P+, 1P-)	-	21PV 5102				
40 A	Single PV circuit	2 P+, 1 P-	-	21PV 3124	MC01 type Blue 2119 1012	Red / Yellow IP65 2119 3313	165 ... 200 mm 2107 0516	1 contact NC+NO 2119 0001
	PV + AC circuit	2 P+, 1 P-	2 P	21PV 3184				
	Dual PV circuit	2 x (1P+, 1P-)	-	21PV 6124	MC01 type Blue 2119 1412			

(1) 45 mm modular DIN front plate included.

(2) Standard handle.

(3) Default connected device (see "Poles connections").

1000 VDC - DIN rail or back plate mounting

Rating (A)	Circuit type	Number of poles by PV polarity ⁽³⁾	No of poles AC current	Switch body	Direct handle ⁽¹⁾	External handle	Shaft for external handle	Auxiliary contact
25 A	Single PV circuit	2 P+, 1 P-	Please consult us	21PV 3722	MC0 type Blue 2119 0012 ⁽²⁾	Black MC1 type IP65 2119 3312 ⁽²⁾	165 ... 200 mm 2107 0516	1 contact NO + NC 2119 0001
	Dual PV circuit	2 x (1P+, 1P-)		21PV 6722	MC01 type Blue 2119 1012			
40 A	Single PV circuit	2 P+, 2 P-		21PV 4754	MC0 type Blue 2119 0012 ⁽²⁾			
	Dual PV circuit	2 x (2 P+, 2 P-)		21PV 8154	MC01 type Blue 2119 1412			

(1) 45 mm modular DIN front plate included.

(2) Standard handle.

(3) Default connected device (see "Poles connections").

Accessories

Direct operation handle

Use

The direct operation conversion kit requires an additional 4 mm distance on each side of the 2 and 3 pole device.

Rating (A)	Handle colour	Type of locking	Handle type	45 mm modular DIN front plate	Reference
25 ... 40	Blue	-	MC0	yes	2119 0012 ⁽¹⁾
25 ... 40	Blue	1 padlock Ø 5 mm	MC01	yes	2119 1012

(1) Standard handle.

2 MPPT 600 V

Rating (A)	Handle colour	Type of locking	Handle type	45 mm modular DIN front plate	Reference
30	Blue	-	MC0	yes	2119 0012
30	Blue	1 padlock Ø 5 mm	MC01	yes	2119 1012
40	Blue	1 padlock Ø 5 mm	MC01	yes	2119 1412

2 MPPT 1000 V

Rating (A)	Handle colour	Type of locking	Handle type	45 mm modular DIN front plate	Reference
25 ... 40	Blue	1 padlock Ø 5 mm	MC01	yes	2119 1412



MC0 handle



MC01 handle

Door interlocked external operation handle

Use

The external control will allow the operator to safely disconnect and isolate the solar strings prior to any intervention.

External controls are user-friendly and adapted to meet requirements of residential installations, large roofs and ground-based generators.

DIN-rail or back plate mounting

Rating (A)	Handle type	Handle colour	Type of locking	External IP ⁽¹⁾	Reference
25 ... 40	MC1	Black	3 padlocks Ø 9 mm	IP65	2119 3312 ⁽²⁾⁽³⁾
25 ... 40	MC1	Red/Yellow	3 padlocks Ø 9 mm	IP65	2119 3313 ⁽³⁾
25 ... 40	S000	Black	3 padlocks Ø 6 mm	IP55	1461 5111
25 ... 40	S000	Black	3 padlocks Ø 6 mm	IP65	1463 5111
25 ... 40	S000	Red/Yellow	3 padlocks Ø 6 mm	IP65	1464 5111

(1) IP: protection degree according to IEC 60529 standard.

(2) Standard handle.

(3) No padlocking.



S000 handle



MC4 handle



MC2 handle

Door mounting

Rating (A)	Handle type	Handle colour	Type of locking	External IP ⁽¹⁾	Reference
25 ... 40	MC2	Blue	-	IP55	2129 0112 ⁽²⁾

(1) IP: protection degree according to IEC 60529 standard.

(2) Standard handle

"Quick Fix" door mounting

Rating (A)	Handle type	Handle colour	Type of locking	External IP ⁽¹⁾	Reference
25 ... 40	MC3	Blue	1 padlock Ø5 mm	IP65	2139 1212 ⁽²⁾
25 ... 40	MC4	Black	3 padlocks Ø9 mm	IP65	2139 3312
25 ... 40	MC4	Red/Yellow	3 padlocks Ø9 mm	IP65	2139 3313

SIRCO MC PV IEC 60947-3

Load break switches for photovoltaic applications
from 25 to 40 A, up to 1000 VDC

Accessories (continued)

Shaft for external handle

Use

MC1 and S000 shafts can be adjusted and cut depending on the need.

Shaft length

- MC1 type:
- 165 mm (adjustable up to 177 mm)
S000 type:
- 150 mm
- 200 mm
- 320 mm



S000 type shaft

access_297.eps

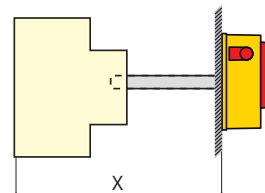

access_308_a_1_x_cat

DIN-rail or back plate mounting				
Rating (A)	Handle type	Dimension X (mm)	Length (mm)	Reference
25 ... 40	MC1	249 ... 259	165	2107 0516
25 ... 40	S000	234 ... 246	150	2107 0515
25 ... 40	S000	284 ... 496	200	2107 0520
25 ... 40	S000	404 ... 416	320	2107 0532

Terminal shrouds

Use

Top or bottom protection against direct contact with the terminals or connection parts.
1 and 3 poles are available.

The SIRCO MC PV load break switch is pre-bridged. Terminal covers are mounted on the top or bottom free space of the device.
Possibility to assemble a terminal shroud on the bridge side by removing the insulating material of the series connection bar (irreversible step).

For SIRCO MC PV				
Rating (A)	Type of mounting	No. of poles	Position	Reference
25 ... 40	rail / door mounting	1 P	top or bottom	2194 1004
25 ... 40	rail / door mounting	3 P	top or bottom	2194 3004

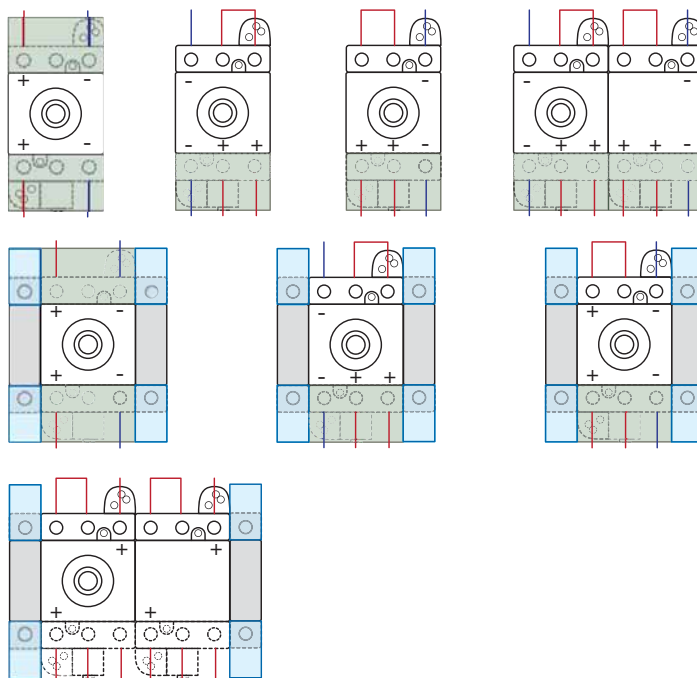

sirco-mc_011_e_1_cat



Terminal shrouds 1 pole



Terminal shrouds 3 pole

Auxiliary contact

Use

These auxiliary contacts signalling position 0 and 1 can be normally open or normally closed contacts. They can be fixed on the left or right side of the switch body and/or on the power additional pole.

Connections

Min./max cross-sections: 1 mm²/4 mm²
 Tightening torque: 0.6 Nm

Rating (A)	Type of mounting	Contact(s)	Contact type	Reference
25 ... 40	DIN-rail / back plate mounted	1 contact	NO + NC	2119 0001
25 ... 40	Door mounted	1 contact	NO + NC	2129 0001

Characteristics according to IEC 60947-5-1

Rating (A)	Contact type	Thermal current I _{th} (A)	Operating current I _e (A)		
			230 VAC AC-15	400 VAC AC-15	690 VAC AC-15
25 ... 40	NO + NC	16	6	4	2



Auxiliary contacts configurations

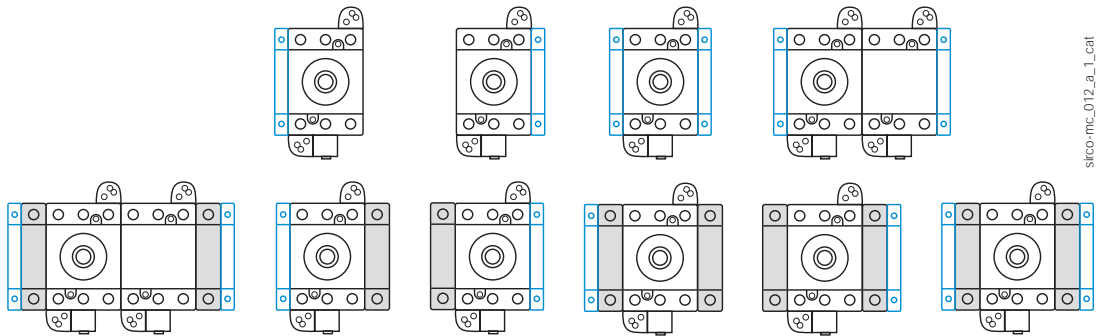

SIRCO MC PV IEC 60947-3

Load break switches for photovoltaic applications
from 25 to 40 A, up to 1000 VDC

Characteristics according to IEC 60947-3

25 to 40 A

Rated current	25 A	30 A	40 A
Thermal current I_{th} at 40°C (A)	25	30	40
Thermal current at 50°C (A)	25	30	40
Thermal current at 60°C (A)	25	30	40
Rated insulation voltage U_i (V)	1000	1000	1000
Rated impulse withstand voltage U_{imp} (kV)	8	8	8

Rated operational currents I_e (A)

Rated voltage	Utilisation category	Circuit type	Number of poles of the device	Number of pole(s) in series per polarity	(A)	(A)	(A)
600 VDC	DC-21 B	Single PV circuit	2 P	1 P+ and 1 P-	-	30	-
600 VDC	DC-21 B	Single PV circuit	3 P	2 P+ and 1 P-	-	-	40
600 VDC	DC-21 B	Dual PV circuit	4 P	2 x (1 P+ and 1 P-)	-	30	-
600 VDC	DC-21 B	Dual PV circuit	6 P	2 x (2 P+ and 1 P-)	-	-	40
1000 VDC	DC-21 B	Single PV circuit	3 P	2 P+ and 1 P-	25	-	-
1000 VDC	DC-21 B	Single PV circuit	4 P	2 P+ and 2 P-	-	-	40
1000 VDC	DC-21 B	Dual PV circuit	6 P	2 x (2 P+ and 1 P-)	25	-	-
1000 VDC	DC-21 B	Dual PV circuit	8 P	2 x (2 P+ and 2 P-)	-	-	40

Connection

Minimum Cu cable cross-section	1.5	1.5	1.5
Maximum Cu cable cross-section (mm ²)	10	10	10
Tightening torque mini / maxi (Nm)	2	2	2

Mechanical characteristics

Durability (number of operating cycles)	30000	30000	30000
Operating torque (Nm)	0.8	0.8	0.8
Weight of a 2 pole PV device (kg)	0.110	0.110	-
Weight of a 3 pole PV device (kg)	0.125	0.125	0.125
Weight of a 2 pole PV and 2 pole AC device (kg)	0.180	0.180	-
Weight of a 3 pole PV and 2 pole AC device (kg)	-	-	0.195
Weight of a 4 pole PV device (kg)	-	-	0.160
Weight of a 4 pole PV device, dual PV circuit (kg)	0.145	0.145	-
Weight of a 6 pole PV device, dual PV circuit (kg)	-	-	0.250
Weight of an 8 pole PV device, dual PV circuit (kg)	-	-	0.320

Dimensions

DIN-rail mounting - Direct operation

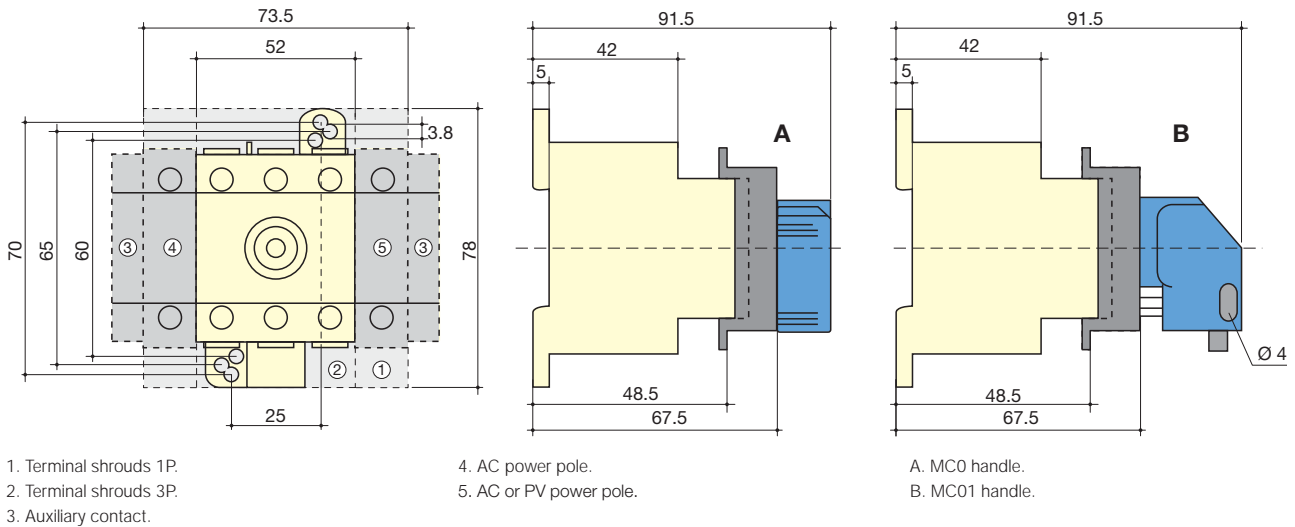

sirco-mc_004_b_1_x_cat

DIN-rail mounting - External operation

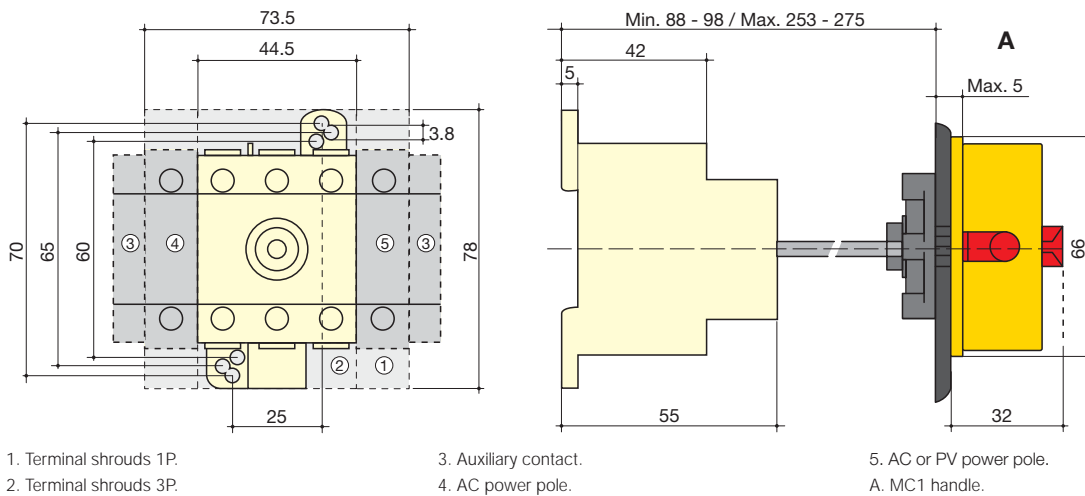

sirco-mc_005_b_1_x_cat

"Quick Fix" door mounting

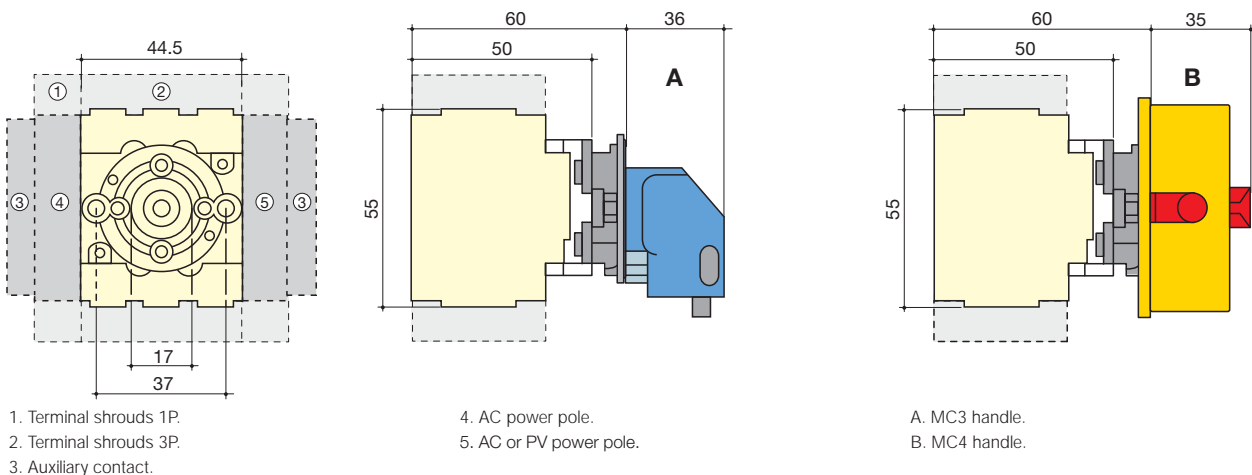

sirco-mc_006_b_1_x_cat

SIRCO MC PV IEC 60947-3

Load break switches for photovoltaic applications
from 25 to 40 A, up to 1000 VDC

Dimensions (continued)

2 MPPT - 40 A - 600 VDC and 25 and 40 A - 1000 VDC - DIN-rail mounting - Direct operation

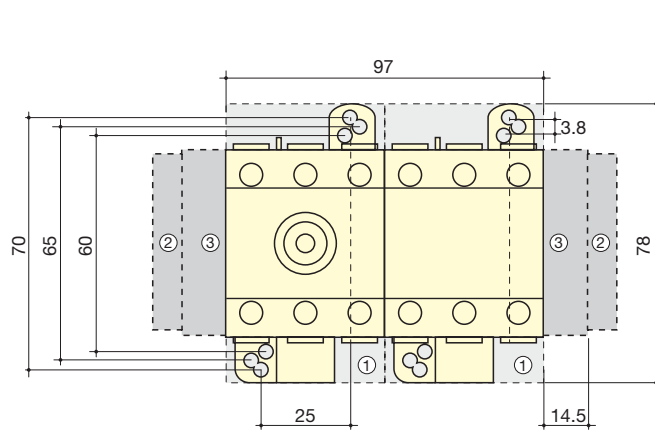

- 1. Terminal shrouds 3P.
- 2. Auxiliary contact.
- 3. PV power pole.

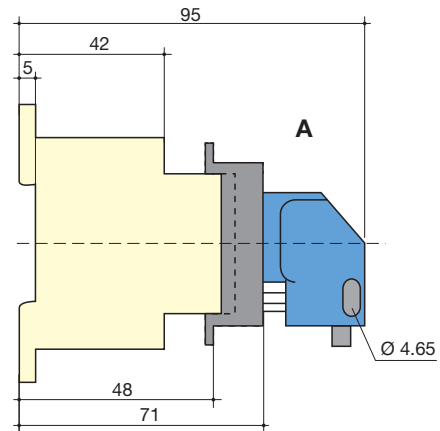

A. MC01 handle.

sirco-mc_039_a_1_x_cat

DIN-rail mounting - External operation

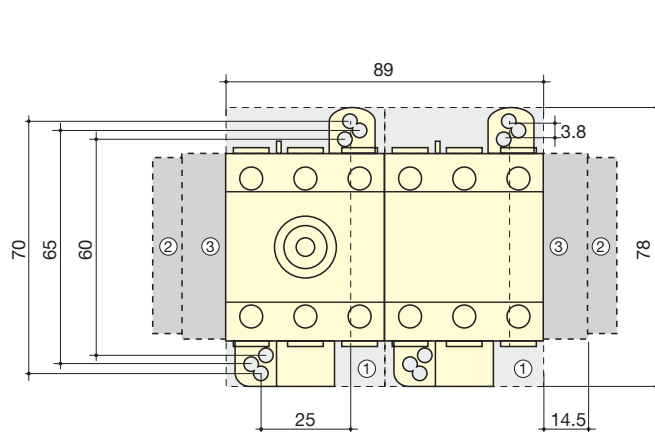

- 1. Terminal shrouds 3P.
- 2. Auxiliary contact.

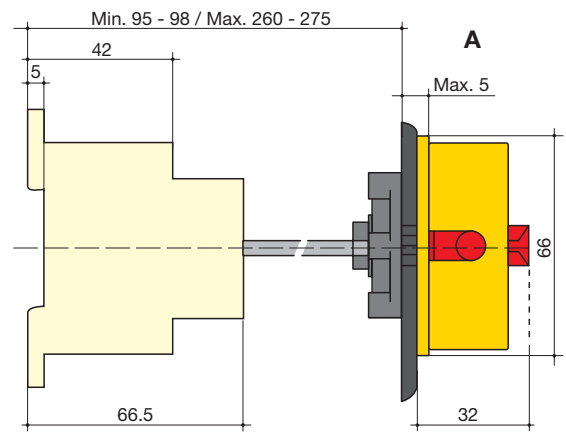

A. MC1 handle.

sirco-mc_040_b_1_x_cat

Dimensions for external handles

DIN-rail or back plate mounting

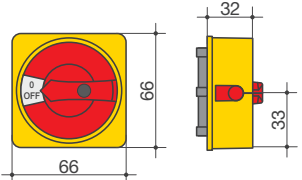
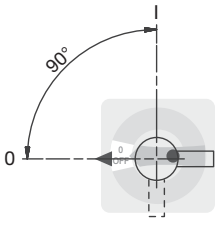
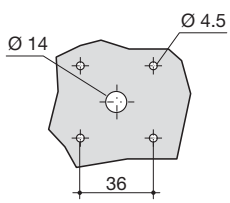
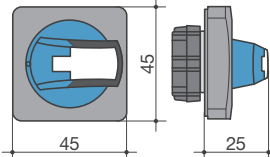
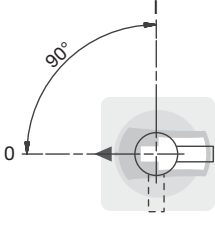
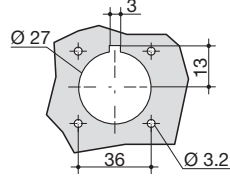
Handle type	Front operation Direction of operation	Door drilling
MC1 type 		
S000 type 		

polgn_006_a_1_gb_cat

Door mounting

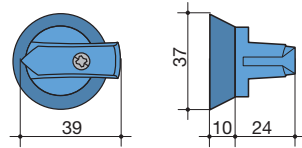
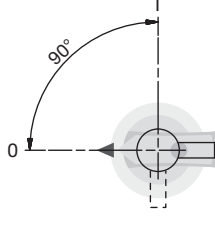
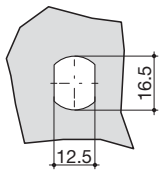
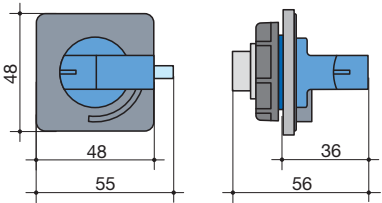
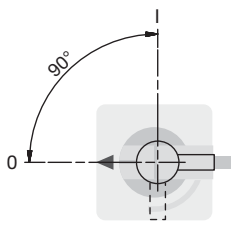
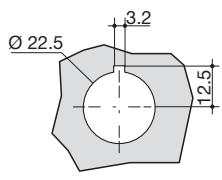
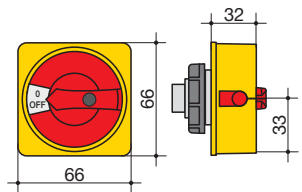
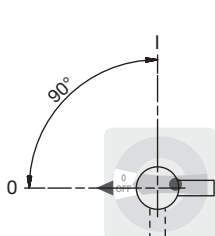
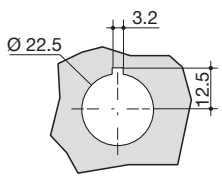
Handle type	Front operation Direction of operation	Door drilling
MC2 type 		
MC3 type Quick Fix 		
MC4 type Quick Fix 		

polgn_007_a_1_gb_cat

SIRCO MC PV IEC 60947-3

Load break switches for photovoltaic applications
from 25 to 40 A, up to 1000 VDC

Poles connections

Switching of polarities + and -

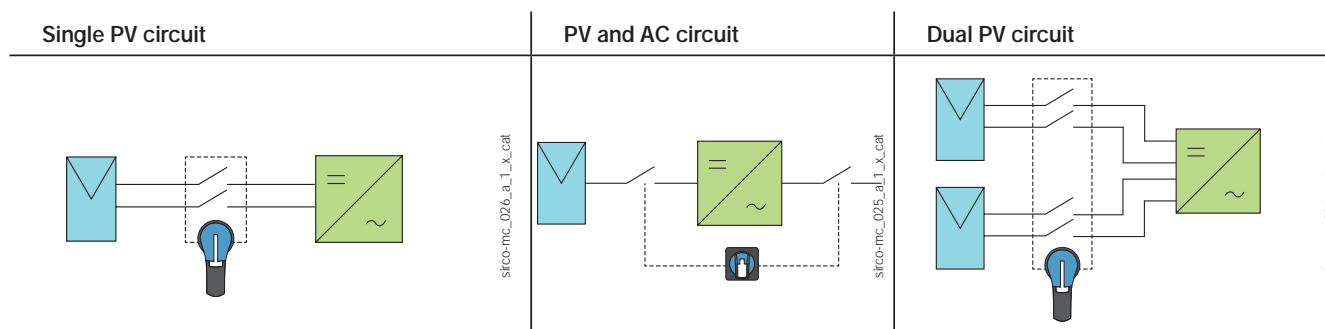

Direct operation

Rating	Single PV circuit	PV and AC circuit	Dual PV circuit
25 A - 600 VDC	<p>21PV 2102</p> <p>Diagram showing terminal connections for a single PV circuit. Terminals 1, 3, 5 are labeled 'Onduleur' and terminals 2, 4, 6 are labeled 'Panneaux'. A central terminal is labeled 'Inverter'.</p>	<p>21PV 2162</p> <p>Diagram showing terminal connections for a PV and AC circuit. Terminals 1, 3, 5 are labeled 'Inverter' and terminals 2, 4, 6 are labeled 'Panel'. Two side terminals are labeled 'AC'.</p>	<p>21PV 5102</p> <p>Diagram showing terminal connections for a dual PV circuit. Terminals 1, 3, 5 are labeled 'Inverter 1' and terminals 2, 4, 6 are labeled 'Panel 1'. Terminals 7, 8 are labeled 'Inverter 2' and terminals 8, 2 are labeled 'Panel 2'.</p>
40 A - 600 VDC 25 A - 1000 VDC	<p>21PV 3124 21PV 3722</p> <p>Diagram showing terminal connections for a single PV circuit. Terminals 1, 3, 5 are labeled 'Inverter' and terminals 2, 4, 6 are labeled 'Panel'. A central terminal is labeled 'Inverter'.</p>	<p>21PV 3184</p> <p>Diagram showing terminal connections for a PV and AC circuit. Terminals 1, 3, 5 are labeled 'Inverter' and terminals 2, 4, 6 are labeled 'Panel'. Two side terminals are labeled 'AC'.</p>	<p>21PV 6124 21PV 6722</p> <p>Diagram showing terminal connections for a dual PV circuit. Terminals 1, 3, 5 are labeled 'Inverter 1' and terminals 2, 4, 6 are labeled 'Panel 1'. Terminals 7, 8 are labeled 'Inverter 2' and terminals 8, 2 are labeled 'Panel 2'.</p>
40 A - 1000 VDC	<p>21PV 4754</p> <p>Diagram showing terminal connections for a single PV circuit. Terminals 1, 3, 5 are labeled 'Panel' and terminals 2, 4, 6 are labeled 'Inverter'. Terminals 7, 8 are labeled 'Panel' and terminals 8, 2 are labeled 'Inverter'.</p>		<p>21PV 8154</p> <p>Diagram showing terminal connections for a dual PV circuit. Terminals 1, 3, 5 are labeled 'Inverter 1' and terminals 2, 4, 6 are labeled 'Panel 1'. Terminals 7, 8 are labeled 'Inverter 2' and terminals 8, 2 are labeled 'Panel 2'.</p>

Switching of polarities + and -

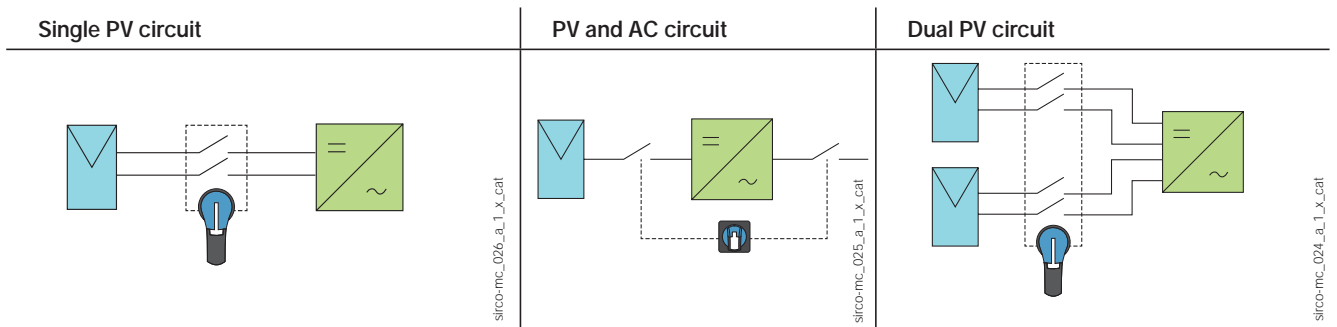

Door mounting

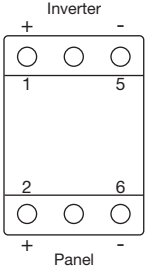
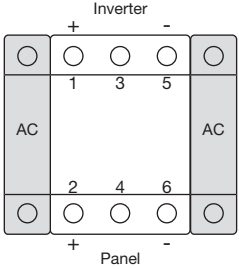
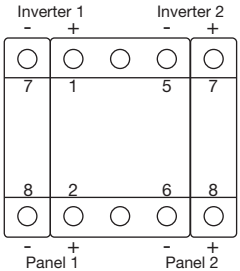
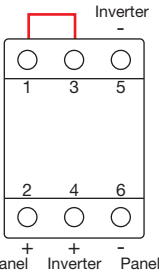
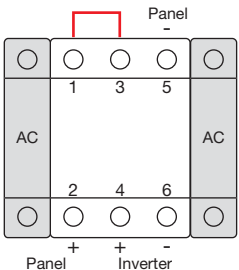
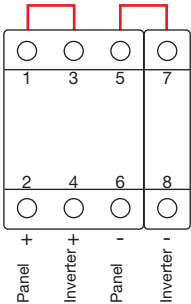
Rating	Single PV circuit	PV and AC circuit	Dual PV circuit
25 A - 600 VDC	<p>21PV 2202 21PV 2302</p>  <p style="text-align: right; font-size: small;">sirco-mc_049_a_1_gb_cat</p>	<p>21PV 2262 21PV 2362</p>  <p style="text-align: right; font-size: small;">sirco-mc_008_a_1_gb_cat</p>	<p>21PV 5202 21PV 5302</p>  <p style="text-align: right; font-size: small;">sirco-mc_050_a_1_gb_cat</p>
40 A - 600 VDC 25 A - 1000 VDC	<p>21PV 3224 21PV 3324 21PV 3822 21PV 3922</p>  <p style="text-align: right; font-size: small;">sirco-mc_051_a_1_gb_cat</p>	<p>21PV 3284 21PV 3384</p>  <p style="text-align: right; font-size: small;">sirco-mc_010_a_1_gb_cat</p>	
40 A - 1000 VDC	<p>21PV 4854 21PV 4954</p>  <p style="text-align: right; font-size: small;">sirco-mc_052_a_1_gb_cat</p>		

SIRCO PV IEC 60947-3

Load break switches for photovoltaic applications
from 100 to 3200 A, up to 1500 VDC

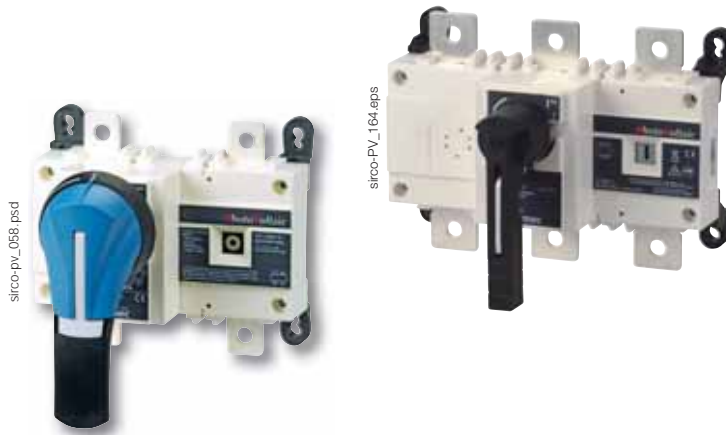

The solution for

- > Combiner box
- > Recombiner box
- > Inverter



Strong points

- > Patented switching technology up to 500 VDC/pole
- > Positive indication
- > Up to 1500 VDC according to IEC 60947-3

Conformity to standards

- > IEC 60947-3
- > IEC 60364-7-712
- > UL 98B⁽¹⁾



Approvals and certifications⁽¹⁾



⁽¹⁾ Product reference on request.

Function

SIRCO PV are manually operated load break switches. Making and breaking capacity under load conditions up to 1500 VDC. These extremely durable switches have been tested and approved for use in the most demanding applications. They have been designed and tested for all types of applications: grounded, floating or bipolar.

Advantages

Optimise your investment

- Thanks to a reduced number of bridging bars, you can limit your costs and save mounting time.
- A 2 poles SIRCO PV will reduce heating and can be integrated in a smaller enclosure.

High quality materials

SIRCO PV is an extremely robust device in a glass fibre reinforced polyester frame. This material provides:

- high mechanical strength,
- stability to temperature variations (RTI of 130°C),
- high dielectric strength (high CTI / tested as per standard ASTM D 2303).

Take advantage of an innovative design

The SIRCO PV can be directly connected to up to four independent PV panel strings. The global solution cost is therefore reduced in comparison with the use of four distinct switches.

Reliability and performance

Our range of SIRCO PV load break switches is compliant to standards UL98B and IEC 60947-3.





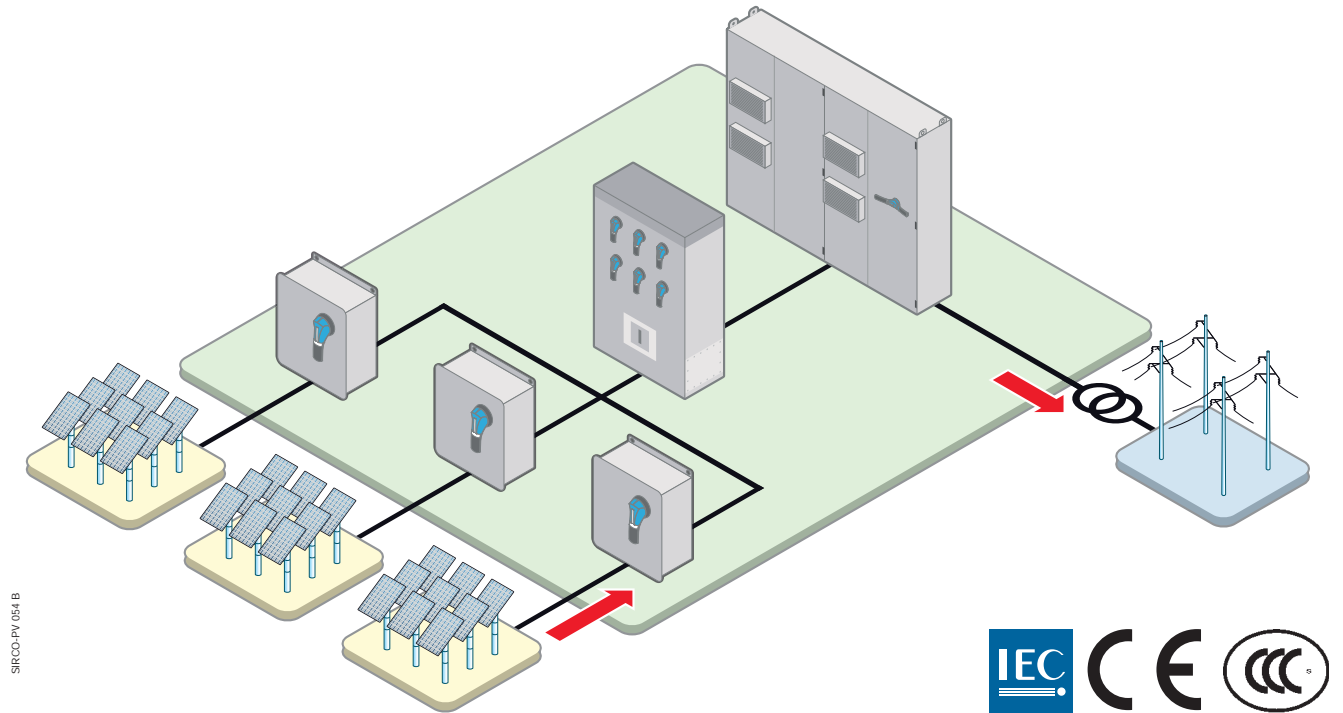

SIRCO PV have been tested to critical currents and at a 10 kA short-circuit during 50 ms without specific protection.

Typical PV architecture

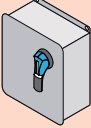
The SIRCO PV range provides safe disconnection and isolation at all levels within your PV installation.

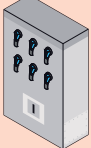

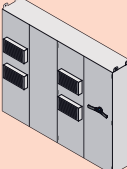
The SOCOMEC solutions

LEVEL OF INSTALLATION	SOCOMEK SOLUTIONS		
Combiner box			SIRCO PV One circuit up to 400 A at 1500 VDC
Recombiner box			SIRCO PV 4 circuits up to 500 A at 1000 VDC ⁽¹⁾ 2 circuits up to 500 A at 1500 VDC
Inverter			SIRCO PV One circuit up to 3200 A at 1000 VDC up to 2000 A at 1500 VDC

⁽¹⁾ Please consult us.

SIRCO PV IEC 60947-3

Load break switches for photovoltaic applications
from 100 to 3200 A, up to 1500 VDC

References

1000 VDC - Back mounting

Rating (A)	Frame size	Number of poles	Switch body	Direct handle	External handle	Shaft for external handle	Quantity to be ordered to connect 2 poles in series		
1 PV circuit									
100 A	B4	2 P	26PV 2010	J1 type Black 1112 1111 Red 1113 1111	S2 type ⁽¹⁾ Black IP55 1421 2111 Black IP65 1423 2111 Red/Yellow IP65 1424 2111	200 mm 1400 1020 320 mm 1400 1032 400 mm 1400 1040	-		
160 A	B4	2 P	26PV 2016						
250 A	B4	2 P	26PV 2025						
315 A	B4	2 P	26PV 2031						
400 A	B4	4 P	26PV 4040						
500 A	B4	4 P	26PV 4050						
630 A	B5	4 P	26PV 4063						
800 A	B5	4 P	26PV 4080						
1250 A	B6	4 P	26PV 4120					J4 type Black 1142 1111 Red 1143 1111	S4 type ⁽¹⁾ Black IP65 1443 3111 Red/Yellow IP65 1444 3111
2000 A	B7	4 P	26PV 4200	2 x 2609 1200					
3200 A	B8	4 P	26PV4320	V1 type Black IP65 2799 7145	320 mm 2799 3018 450 mm 2799 3019	2 x 2609 1200			
2 PV circuits									
100 A	B4 _{DS}	4 P	26PV 5010	J2 type Black 1122 1111 Red 1123 1111	S2 type ⁽¹⁾ Black IP55 1421 2111 Black IP65 1423 2111 Red/Yellow IP65 1424 2111	200 mm 1400 1020 320 mm 1400 1032 400 mm 1400 1040	-		
160 A	B4 _{DS}	4 P	26PV 5016						
250 A	B4 _{DS}	4 P	26PV 5025						
315 A	B4 _{DS}	4 P	26PV 5031						
630 A	B5 _{DS}	8 P	26PV 8063	J4 type Black 1142 1111 Red 1143 1111	S4 type ⁽¹⁾ Black IP65 1443 3111 Red/Yellow IP65 1444 3111	200 mm 1401 1520 320 mm 1401 1532 400 mm 1401 1520	2 x 2709 0027		
800 A	B6 _{DS}	8 P	26PV 8080				V1 type Black IP65 2799 7145	320 mm 4199 3018	1 x 2609 1100
1250 A	B6 _{DS}	8 P	26PV 8120						1 x 2609 1200
2000 A	B7 _{DS}	8 P	26PV 8200						

(1) Defeatable handle.

1500 VDC - Back mounting

Rating (A)	Frame size	Number of poles	Switch body	Direct handle	External handle	Shaft for external handle	Quantity to be ordered to connect 2 poles in series		
1 PV circuit									
160 A	B4T	3 P	26PV 3015	J1 type Black 1112 1111 Red 1113 1111	S2 type ⁽¹⁾ Black IP55 1421 2111 Black IP65 1423 2111 Red/Yellow IP65 1424 2111	200 mm 1400 1020 320 mm 1400 1032 400 mm 1400 1040	Standard bridging bar 1 x 2609 0026		
250 A	B4T	3 P	26PV 3024						
315 A	B4T	3 P	26PV 3030						
400 A	B4T	3 P	26PV 3039					J4 type Black 1142 1111 Red 1143 1111	V1 type Black IP65 2799 7145
800 A	B6 _{DS}	8 P	26PV 8080	320 mm 4199 3018	1 x 2609 1100				
1250 A	B6 _{DS}	8 P	26PV 8120			1 x 2609 1200			
2000 A	B7 _{DS}	8 P	26PV 8200						

(1) Defeatable handle.

Accessories

Direct operation handle

Frame size	Handle type	Handle colour	Reference	
B4 ... B5	B2	Black	2699 5052	
		Red	2699 5053	
	J1	Black	1112 1111	
		Red	1113 1111	
B6 ... B7	J4	Black	1142 1111	
		Red	1143 1111	
	B4 _{DS} ... B5 _{DS}	B2	Black	2699 5052
			Red	2699 5053
J4		Black	1142 1111	
		Red	1143 1111	
B6 _{DS} ... B7 _{DS}	J2	Black	1122 1111	
		Red	1123 1111	
	J4	Black	1142 1111	
		Red	1143 1111	
B8	J4	Black	1142 1111	
		Red	1143 1111	



B2 type handle

J1 type handle

J4 type handle

Door interlocked external operation handle

Use

Door interlocked external operation handles include an escutcheon, are padlockable and must be utilised with an extension shaft. In a combiner box, located close to the solar cell strings, or located close to the inverter, we recommend to use a door interlocked external handle for its safety features.

Example

The locking function of the enclosure in the "ON" position will force the operator to safely disconnect and isolate the solar cell strings prior to any intervention.

Opening the door when the switch is on "ON" position is possible by defeating the locking function using a tool (authorised persons only). The interlocking function is restored when the door is re-closed.

Frame size	Handle type	Handle colour	Degree of protection	Reference
B4 ... B5	S2	Black	IP55	1421 2111
	S2	Black	IP65	1423 2111
	S2	Red/ Yellow	IP65	1424 2111
B6 ... B7	S4	Black	IP65	1443 3111
	S4	Red/ Yellow	IP65	1444 3111
B8	V1	Black	IP65	2799 7145
	S2	Black	IP55	1421 2111
B4 _{DS}	S2	Black	IP65	1423 2111
	S2	Red/ Yellow	IP65	1424 2111
B5 _{DS}	S4	Black	IP65	1443 3111
	S4	Red/ Yellow	IP65	1444 3111
B6 _{DS} ... B7 _{DS}	V1	Black	IP65	2799 7145
B8				



Reinforced S2 type handle

S4 type handle

V1 type handle

SIRCO PV IEC 60947-3

Load break switches for photovoltaic applications
from 100 to 3200 A, up to 1500 VDC

Accessories (continued)

Shaft for external handle

Use

Standard lengths:

- 200 mm,
- 320 mm,
- 400 mm.

Other lengths: Please consult us.

Frame size	Handle type	Dimensions X (mm)	Length (mm)	Reference
B4	S2	150 ... 295	200	1400 1020
B4	S2	150 ... 415	320	1400 1032
B4	S2	150 ... 495	400	1400 1040
B5	S2	203 ... 328	200	1400 1020
B5	S2	203 ... 448	320	1400 1032
B5	S2	203 ... 525	400	1400 1040
B6	S4	220 ... 343	200	1401 1520
B6	S4	220 ... 463	320	1401 1532
B6	S4	220 ... 543	400	1401 1540
B7	S4	305 ... 366	200	1401 1520
B7	S4	305 ... 485	320	1401 1532
B7	S4	305 ... 564	400	1401 1540
B8	V1	415 ... 690	320	2799 3018
B8	V1	415 ... 820	450	2799 3019
B4 _{DS}	S2	210...310	200	1400 1020
B4 _{DS}	S2	210...430	320	1400 1032
B4 _{DS}	S2	210...510	400	1400 1040
B5 _{DS}	S4	280...390	200	1401 1520
B5 _{DS}	S4	280...510	320	1401 1532
B5 _{DS}	S4	280...590	400	1401 1540
B6 _{DS}	V1	425...577	320	4199 3018
B6 _{DS}	V1	425...697	400	4199 3019
B7 _{DS}	V1	425...697	320	4199 3018
B7 _{DS}	V1	425...777	400	4199 3019

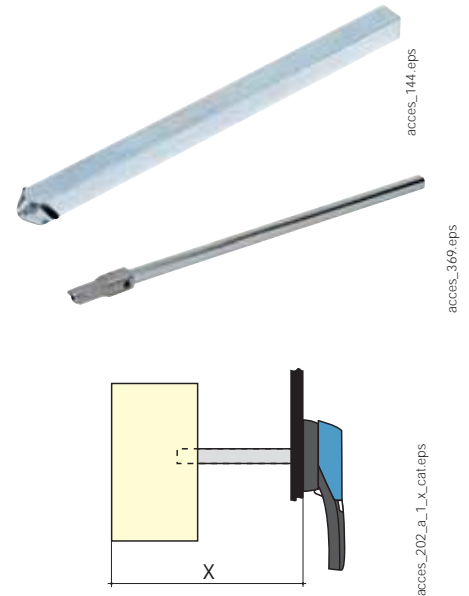

Shaft guide for external operation

Use

To guide the shaft extension into the external handle.

This accessory enables the handle to engage the extension shaft with a misalignment of up to 15 mm.

Required for a shaft length over 320 mm.

Description	Reference
Shaft guide	1429 0000



S-type handle adapter

Use

Enables S-type handles to be fitted in place of existing older style Socomec handles.

Adapter can also be utilised as a spacer to increase the distance between the panel door and the handle lever.

Dimensions

Adds 12 mm to the depth of the handle.

Handle colour	External IP ⁽¹⁾	To be ordered in multiples of	Reference
Black	IP65	1	1493 0000

(1) IP: protection degree according to IEC 60529 standard.



Auxiliary contact

Use

Pre-break and signalling of positions 0 and I:
- 1 to 2 NO/NC auxiliary contacts,
- 1 to 4 NO + NC auxiliary contacts,
- 1 to 2 low level NO/NC auxiliary contacts.

Characteristics

NO/NC AC: IP2 with front operation.

Connection to the control circuit

By 6.35 mm fast-on terminal.

Electrical characteristics

30 000 operations.

NO/NC changeover auxiliary contacts

Frame size	Position AC	Type	Reference
B4 ... B8	1 contact	NO/NC	2699 0031
B4 ... B8	2 contacts	NO/NC	2699 0032
B4 _{DS} ... B7 _{DS}	1 contact	NO/NC	2699 0061
B4 _{DS} ... B7 _{DS}	2 contacts	NO/NC	2699 0062

Low level NO/NC auxiliary contacts

Frame size	Position AC	Type	Reference
B4 ... B7	1 contact	NO/NC	2699 0301
B4 ... B7	2 contacts	NO/NC	2699 0302



access_076.eps

Terminal screen

Use

Top and bottom protection against direct contact with terminals or connection parts.

Frame size	No. of poles	Position	Pack	Reference
B4	2 P	Top or bottom	1 unit	2698 3020
B4T	3 P	Top or bottom	1 unit	26984020
B4	4 P	Top or bottom	1 unit	2698 4020
B5	3 P	Top or bottom	1 unit	2698 3050
B5	4 P	Top or bottom	1 unit	2698 4050
B6	4 P	Top or bottom	1 unit	2698 4080
B7	4 P	Top or bottom	1 unit	2698 4120
B8	4 P	Top or bottom	1 unit	2698 4200
B4 _{DS}	2 P	Top or bottom	1 unit	1509 3025
B5 _{DS}	6 P	Top and bottom	2 units	1509 3063
B5 _{DS}	8 P	Top and bottom	2 units	1509 4063
B6 _{DS}	8 P	Top and bottom	2 units	1509 4080



access_079.eps

Inter-phase barrier

Use

Safe isolation between the terminals.

Frame size	No. of poles	Reference
B4	2 P	2998 0023
B4T	3 P	2998 0023
B4	4 P	2998 0024
B5	4 P	2998 0014
B6...B8	3 P	Included
B6...B8	4 P	Included

The inter-phase barriers are not mandatory but we recommend to separate the polarities + and -.

SIRCO PV IEC 60947-3

Load break switches for photovoltaic applications
from 100 to 3200 A, up to 1500 VDC

Accessories (continued)

Bridging bars for connecting poles in series

Use

The bridging bars permit easy connection of the poles in series, allowing the following configurations⁽¹⁾.

⁽¹⁾ Other connections: refer to mounting instructions.

1000 VDC - 1 independent PV circuit										
Switch body Reference	Rating (A)	Frame size	Fig.	Quantity of bridging bars kits to order per switch - ungrounded	Fig.	Reference				
26PV 4040	400	B4		4		2609 0025				
26PV 4050	500									
26PV 4063	630	B5		4			2709 0027			
26PV 4080	800									
26PV 4120	1250	B6		2				2609 1100		
26PV 4200	2000	B7		2						
26PV 4320	3200	B8		2					2609 1200	
26PV 8063	630	B5 _{DS}		8						
26PV 8080	800	B6 _{DS}		4						2609 1100
26PV 8120	1250									
26PV 8200	2000	B7 _{DS}		4						2609 1200

Bridging bars for connecting poles in series (continued)

Use

The bridging bars permit easy connection of the poles in series, allowing the following configurations⁽¹⁾.

(1) Other connections: refer to mounting instructions.

1500 VDC - 1 independent PV circuit							
Switch body Reference	Rating (A)	Frame size	Quantity to be ordered to connect 2 poles in series	Fig.	Quantity of bridging bars kits to order per switch - ungrounded	Fig.	Reference
26PV 3015	160	B4T	1		1		2609 0026
							2609 0041
26PV 3024	250	B4T	1		1		2609 0026
							2609 0041
26PV 3030	315	B4T	1		1		2609 0026
							2609 0041
26PV 3039	400	B4T	1		1		2609 0026
							2609 0041

SIRCO PV IEC 60947-3

Load break switches for photovoltaic applications
from 100 to 3200 A, up to 1500 VDC

Accessories (continued)



Bridging bars for connecting poles in series (continued)

Use

The bridging bars permit easy connection of the poles in series, allowing the following configurations⁽¹⁾.

⁽¹⁾ Other connections: refer to mounting instructions.

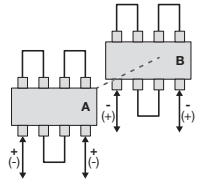
1500 VDC - 1 independent PV circuit

Switch body Reference	Rating (A)	Frame size	Quantity to be ordered to connect 2 poles in series	Fig.	Quantity of bridging bars kits to order per switch - ungrounded	Fig.	Reference
26PV 8080	800	B6 _{DS}	1		4		2609 1100
26PV 8120	1250	B6 _{DS}	1		4		2609 1100
26PV 8200	2000	B7 _{DS}	1		4		2609 1200

Characteristics

Characteristics according to IEC 60947-3

Rated Current I_n			100 A		160 A			250 A			
Reference			26PV 2010	26PV 5010	26PV 2016	26PV 5016	26PV 3015	26PV 2025	26PV 5025	26PV 3024	
Frame size			B4	B4 _{DS}	B4	B4 _{DS}	B4T	B4	B4 _{DS}	B4T	
Thermal current at 40°C (A)			100	100	160	160	160	250	250	250	
Thermal current at 45°C (A)			100	100	160	160	160	250	250	250	
Thermal current at 50°C (A)			100	100	160	160	160	250	250	250	
Thermal current at 55°C (A)			100	100	160	160	160	250	250	250	
Thermal current at 60°C (A)			100	100	160	160	160	250	250	250	
Thermal current at 65°C (A)			100	100	160	160	152	250	250	237	
Thermal current at 70°C (A)			100	100	160	160	144	250	250	225	
Rated insulation voltage U_i (V)			1500	1500	1500	1500	1500	1500	1500	1500	
Rated impulse withstand voltage U_{imp} (kV)			12	12	12	12	12	12	12	12	
Number of circuits	Rated voltage	Utilisation category	100 A		160 A			250 A			
			I_e (A)	I_e (A)	I_e (A)	I_e (A)	I_e (A)	I_e (A)	I_e (A)	I_e (A)	
I_e (A)	1 circuit	1000 VDC	DC-21 B	100	-	160	-	-	250	-	-
	2 circuits			-	100	-	160	-	-	250	-
	1 circuit	1500 VDC	DC-21 B	-	-	-	-	-	-	-	
	2 circuits			-	-	-	-	-	-	-	
1 circuit		DC-PV1	-	-	-	-	160	-	-	250	
Number of pole(s) in series per circuit			1P+; 1P- ⁽¹⁾	1P+; 1P- ⁽²⁾	1P+; 1P- ⁽¹⁾	1P+; 1P- ⁽²⁾	2P+; 1P- ⁽³⁾	1P+; 1P- ⁽¹⁾	1P+; 1P- ⁽²⁾	2P+; 1P- ⁽³⁾	
Number of pole(s) of the device			2 P	4 P	2 P	4 P	3 P	2 P	4 P	3 P	
Short-circuit capacity (without protection)											
Rated short-time withstand current 0.3 s. (kA eff)			10	10	10	10	10	10	10	10	
Rated short-time withstand current 1 s. (kA eff)			5	5	5	5	5	5	5	5	
Power dissipation per poles of the PV switch (W/P) @ 40°C			0.8	0.8	2	2	2.5	4.7	4.7	5	
Humidity according to IEC 60947-1 Annexe Q (%)			95	95	95	95	95	95	95	95	
Connection											
Nominal Cu cable section (mm ²)			35	35	70	70	70	120	120	120	
Nominal Cu busbar width (mm)			32	32	32	32	32	32	32	32	

(1)

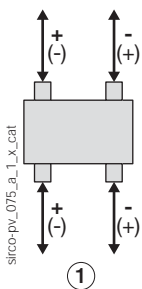

1. Utility 1
2. Utility 2

(2)

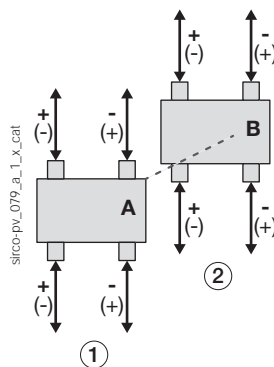

(3)

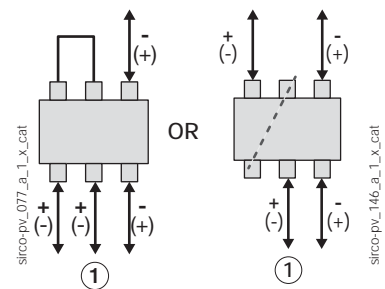

SIRCO PV IEC 60947-3

Load break switches for photovoltaic applications

from 100 to 3200 A, up to 1500 VDC

Characteristics (continued)

Characteristics according to IEC 60947-3

Rated Current I_n				315 A		
Reference				26PV 2031	26PV 5031	26PV 3030
Frame size				B4	B4_{DS}	B4T
Thermal current at 40°C (A)				315	315	315
Thermal current at 45°C (A)				315	315	315
Thermal current at 50°C (A)				315	315	315
Thermal current at 55°C (A)				315	315	315
Thermal current at 60°C (A)				315	315	315
Thermal current at 65°C (A)				315	315	299
Thermal current at 70°C (A)				315	315	283
Rated insulation voltage U_i (V)				1500	1500	1500
Rated impulse withstand voltage U_{imp} (kV)				12	12	12
Number of circuits		Rated voltage	Utilisation category	I_e (A)	I_e (A)	I_e (A)
I_e (A)	1 circuit	1000 VDC	DC-21 B	315	315	-
	2 circuits			-		-
	1 circuit	1500 VDC	DC-21 B	-	-	-
	2 circuits			-		-
	1 circuit		DC-PV1	-	-	315
Number of pole(s) in series per circuit				1P+; 1P ^{.(1)}	1P+; 1P ^{.(2)}	2P+; 1P ^{.(3)}
Number of pole(s) of the device				2 P	4 P	3 P
Short-circuit capacity (without protection)						
Rated short-time withstand current 0.3 s. (kA eff)				10	10	10
Rated short-time withstand current 1 s. (kA eff)				5	5	5
Power dissipation per poles of the PV switch (W/P) @ 40°C				8	8	9.5
Humidity according to IEC 60947-1 Annexe Q (%)				95	95	95
Connection						
Nominal Cu cable section (mm ²)				185	185	185
Nominal Cu busbar width (mm)				32	32	32

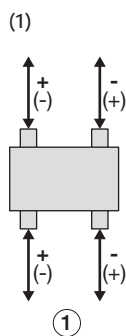

1. Utility 1
2. Utility 2

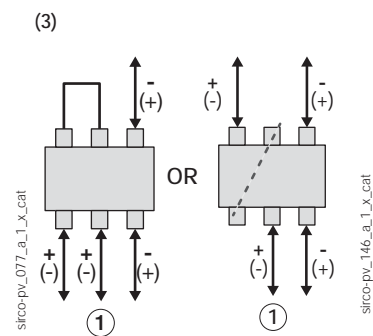
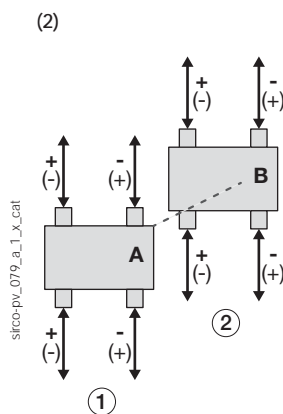

Characteristics according to IEC 60947-3

Rated Current I_n				400 A		500 A
Reference				26PV 4040	26PV 3039	26PV 4050
Frame size				B4	B4T	B4
Thermal current at 40°C (A)				400	400	500
Thermal current at 45°C (A)				400	400	500
Thermal current at 50°C (A)				400	400	500
Thermal current at 55°C (A)				400	400	500
Thermal current at 60°C (A)				400	400	500
Thermal current at 65°C (A)				380	380	475
Thermal current at 70°C (A)				360	360	450
Rated insulation voltage U_i (V)				1500	1500	1500
Rated impulse withstand voltage U_{imp} (kV)				12	12	12
Number of circuits	Rated voltage	Utilisation category	I_e (A)	I_e (A)	I_e (A)	
I_e (A)	1 circuit	1000 VDC	400	-	500	
	2 circuits		-	-	-	
	1 circuit	1500 VDC	-	-	-	
	2 circuits		-	-	-	
	1 circuit		-	400	-	
Number of pole(s) in series per circuit			2P+; 2P- ⁽¹⁾	2P+; 1P- ⁽²⁾	2P+; 2P- ⁽¹⁾	
Number of pole(s) of the device			4 P	3 P	4 P	
Short-circuit capacity (without protection)						
Rated short-time withstand current 0.3 s. (kA eff)			10	10	10	
Rated short-time withstand current 1 s. (kA eff)			5	5	5	
Power dissipation per poles of the PV switch (W/P) @ 40°C			20	15	30	
Humidity according to IEC 60947-1 Annexe Q (%)			95	95	95	
Connection						
Nominal Cu cable section (mm ²)			240	240	2 x 150	
Nominal Cu busbar width (mm)			32	32	32	

(1)

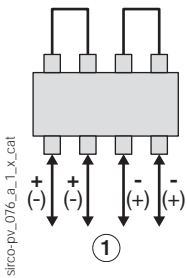

(2)

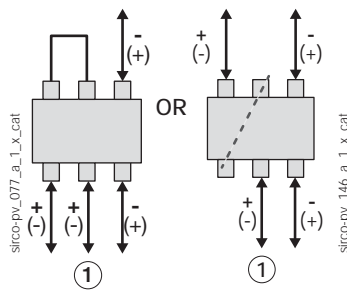

SIRCO PV IEC 60947-3

Load break switches for photovoltaic applications

from 100 to 3200 A, up to 1500 VDC

Characteristics (continued)

Characteristics according to IEC 60947-3

Rated Current I_n			630 A		800 A		
Reference			26PV 4063	26PV 8063	26PV 4080	26PV 8080	
Frame size			B5	B5 _{DS}	B5	B5 _{DS}	
Thermal current at 40°C (A)			630	630	800	800	
Thermal current at 45°C (A)			630	630	760	760	
Thermal current at 50°C (A)			630	630	720	720	
Thermal current at 55°C (A)			630	630	685	685	
Thermal current at 60°C (A)			560	560	650	650	
Thermal current at 65°C (A)			540	540	620	620	
Thermal current at 70°C (A)			510	510	590	590	
Rated insulation voltage U_i (V)			1500	1500	1200	1500	
Rated impulse withstand voltage U_{imp} (kV)			12	12	12	12	
Number of circuits	Rated voltage	Utilisation category	I_e (A)	I_e (A)	I_e (A)	I_e (A)	
I_e (A)	1 circuit	1000 VDC	DC-21 B	630	-	800	-
	2 circuits			-	630	-	800
	1 circuit	1500 VDC	DC-21 B	-	-	-	800
	2 circuits			-	-	-	-
Number of pole(s) in series per circuit			2P+; 2P- ⁽¹⁾	2P+; 2P- ⁽²⁾	2P+; 2P- ⁽¹⁾	2P+; 2P- ⁽²⁾	
Number of pole(s) of the device			4 P	8 P	4 P	8 P	
Short-circuit capacity (without protection)							
Rated short-time withstand current 0.3 s. (kA eff)			10	10	10	10	
Rated short-time withstand current 1 s. (kA eff)			5	5	5	5	
Power dissipation per poles of the PV switch (W/P) @ 40°C			40	40	70	70	
Humidity according to IEC 60947-1 Annexe Q (%)			95	95	95	95	
Connection							
Nominal Cu cable section (mm ²)			2 x 185	2 x 185	2 x 240	2 x 240	
Nominal Cu busbar width (mm)			40	40	50	50	

(1)

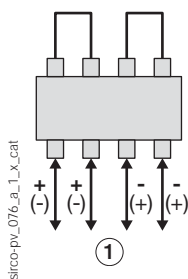

(2)

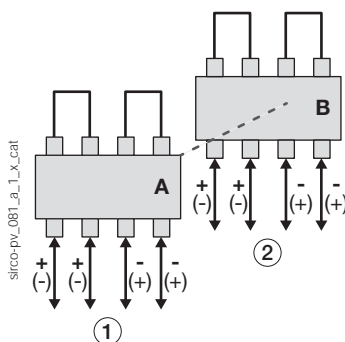

(3)

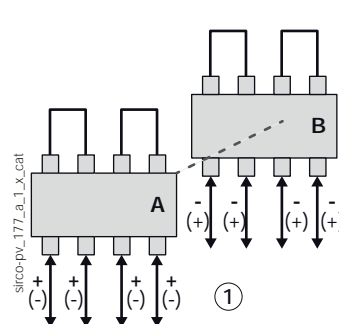

1. Utility 1
2. Utility 2

Characteristics according to IEC 60947-3

Rated Current I_n			1250 A			2000 A			3200 A
Reference			26PV 4120	26PV 8120		26PV 4200	26PV 8200		26PV 4320
Frame size			B6	B6_{DS}		B7	B7_{DS}		B8
Thermal current at 40°C (A)			1250	1250		2000	2000		3200
Thermal current at 45°C (A)			1250	1250		2000	2000		3200
Thermal current at 50°C (A)			1250	1250		1850	1850		3200
Thermal current at 55°C (A)			1180	1180		1730	1730		3040
Thermal current at 60°C (A)			1125	1125		1600	1600		2888
Thermal current at 65°C (A)			1050	1050		1520	1520		2743
Thermal current at 70°C (A)			1000	1000		1440	1440		2606
Rated insulation voltage U_i (V)			-	-		1500	1500		1500
Rated impulse withstand voltage U_{imp} (kV)			12	12		12	12		12
Number of circuits	Rated voltage	Utilisation category	I_e (A)	I_e (A)	I_e (A)	I_e (A)	I_e (A)	I_e (A)	I_e (A)
I_e (A)	1 circuit	1000 VDC	DC-21 B	1250	-	-	2000	-	3200
	2 circuits			-	1250	-	-	2000	-
	1 circuit	1500 VDC	DC-21 B	-	-	1250	-	2000	-
	2 circuits			-	-	-	-	-	-
Number of pole(s) in series per circuit			2P+; 2P- ⁽¹⁾	2P+; 2P- ⁽²⁾	4P+; 4P- ⁽³⁾	2P+; 2P- ⁽¹⁾	2P+; 2P- ⁽²⁾	4P+; 4P- ⁽³⁾	4P+; 4P- ⁽¹⁾
Number of pole(s) of the device			4 P	8 P		4 P	8 P		4 P
Short-circuit capacity (without protection)									
Rated short-time withstand current 0.3 s. (kA eff)			10	10		10	10		10
Rated short-time withstand current 1 s. (kA eff)			5	5		5	5		5
Power dissipation per poles of the PV switch (W/P) @ 40°C			-	63		-	125		-
Humidity according to IEC 60947-1 Annexe Q (%)			95	95		95	95		95
Connection									
Nominal Cu cable section (mm ²)			2 x 240	2 x 240		-	-		-
Nominal Cu busbar width (mm)			63	63		100	100		4 x 100 x 5

(1)

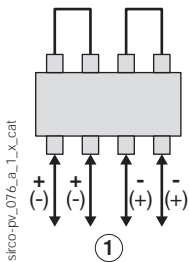

- 1. Utility 1
- 2. Utility 2

(2)

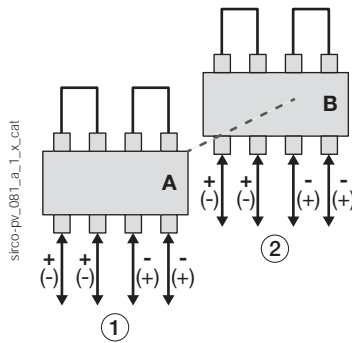

(3)

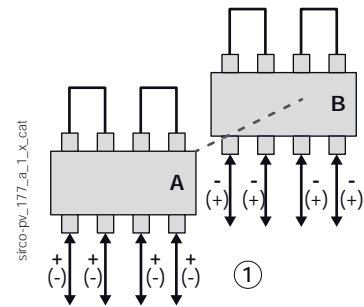

SIRCO PV IEC 60947-3

Load break switches for photovoltaic applications
from 100 to 3200 A, up to 1500 VDC

Dimensions (mm)

100 to 315 A - B4 - 2P - 1000 VDC - 1 circuit

26PV 2010 - 26PV 2016 - 26PV 2025 - 26PV 2031

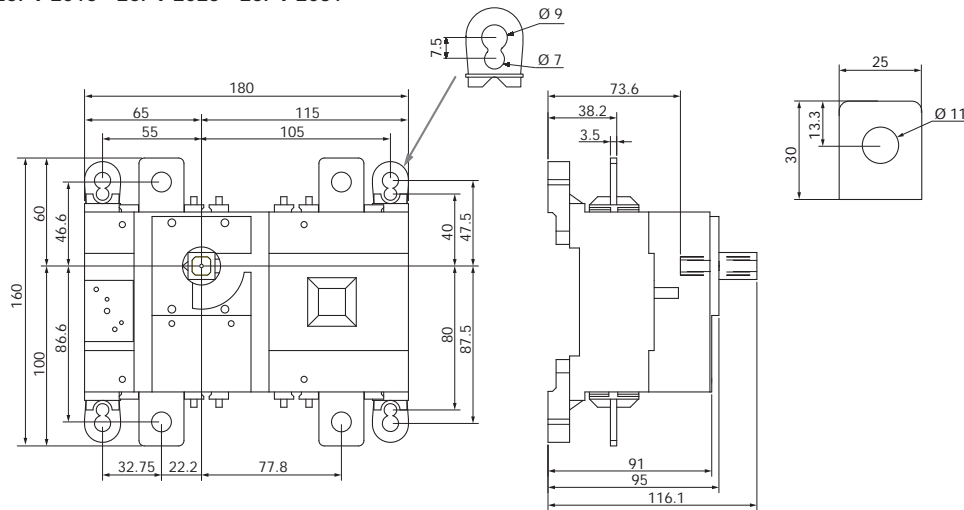

sirco-pv_141_a_1_x_catal.ai

400 to 500 A - B4 - 4P - 1000 VDC - 1 circuit

26PV 4040 - 26PV 4050

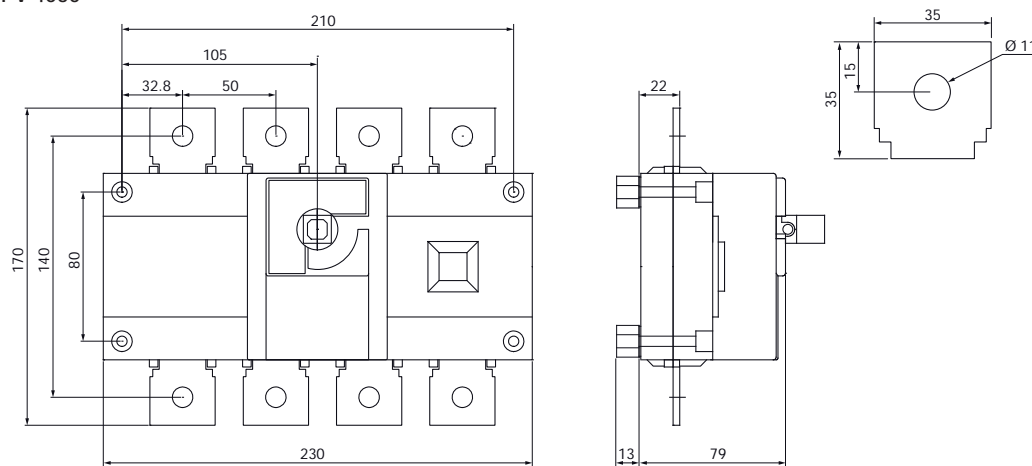

sirco-pv_142_a_1_x_catal.ai

630 to 800 A - B5 - 4P - 1000 VDC - 1 circuit

26PV 4063 - 26PV 4080

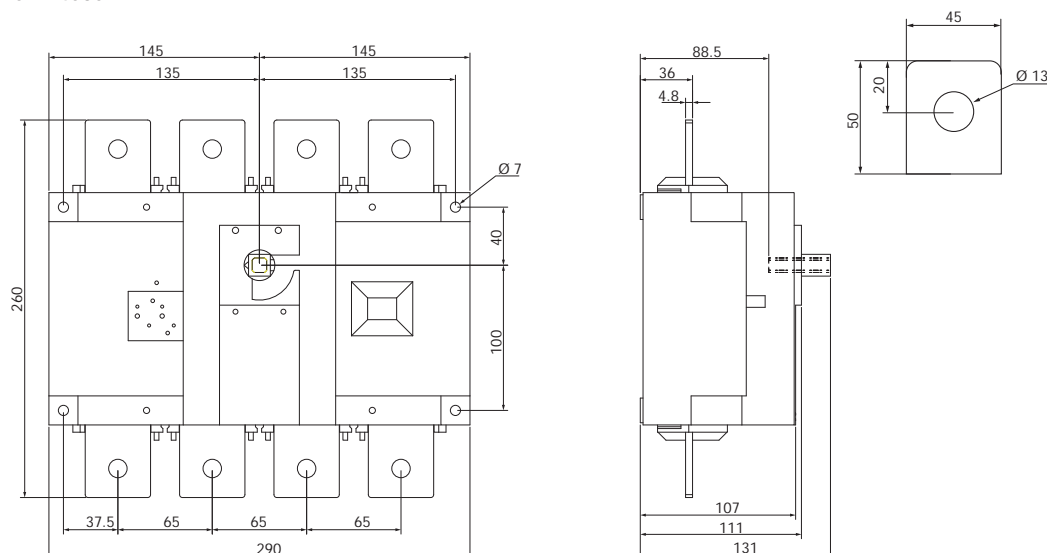

sirco-pv_143_a_1_x_catal.ai

1250 A - B6 - 4P - 1000 VDC - 1 circuit

26PV 4120

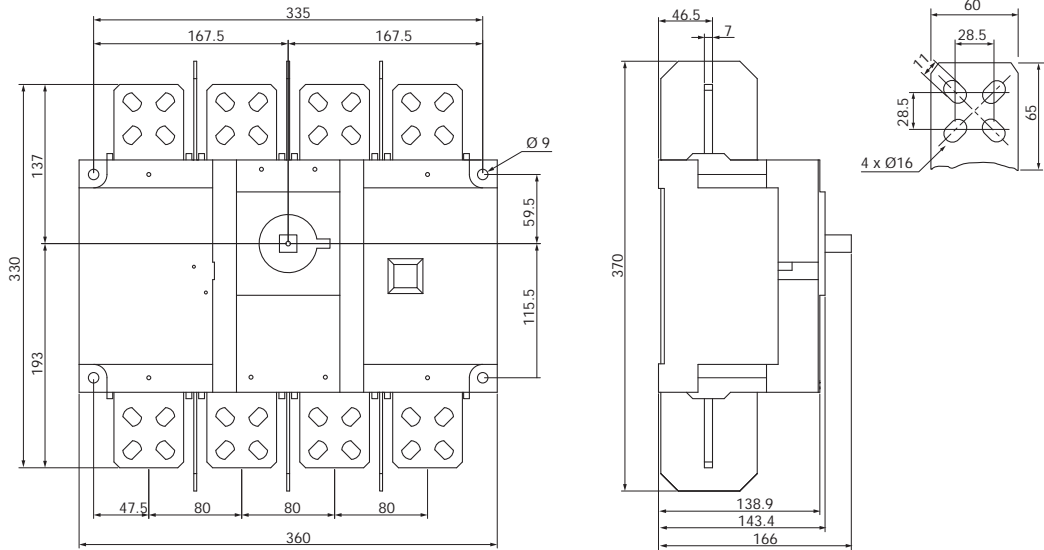

sirco-pv_144_a_1_x_cat.ai

2000 A - B7 - 4P - 1000 VDC - 1 circuit

26PV 4200

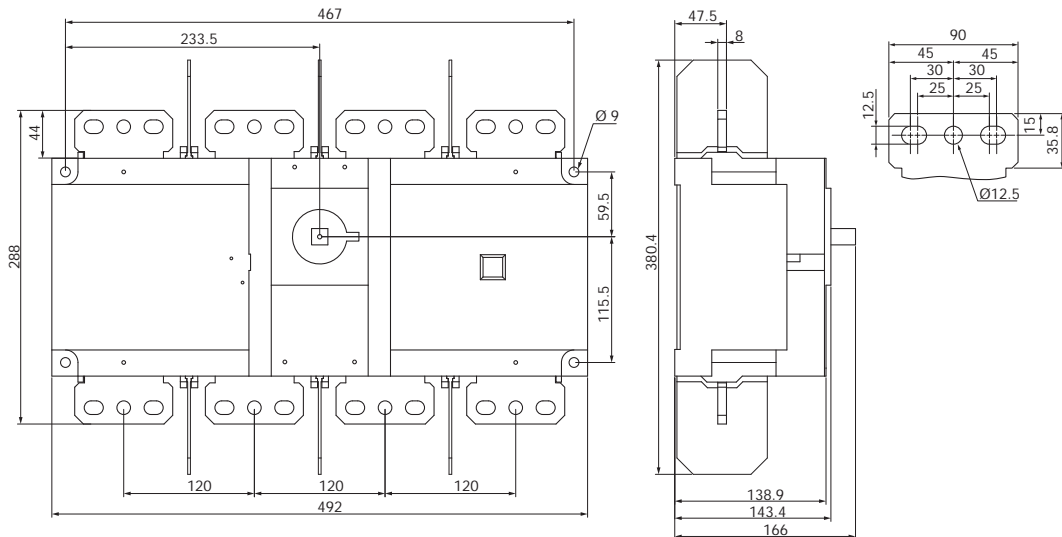

sirco-pv_145_a_1_x_cat.ai

SIRCO PV IEC 60947-3

Load break switches for photovoltaic applications
from 100 to 3200 A, up to 1500 VDC

Dimensions (mm) (continued)

3200 A - B8 - 4P - 1000 VDC - 1 circuit

26PV 4320

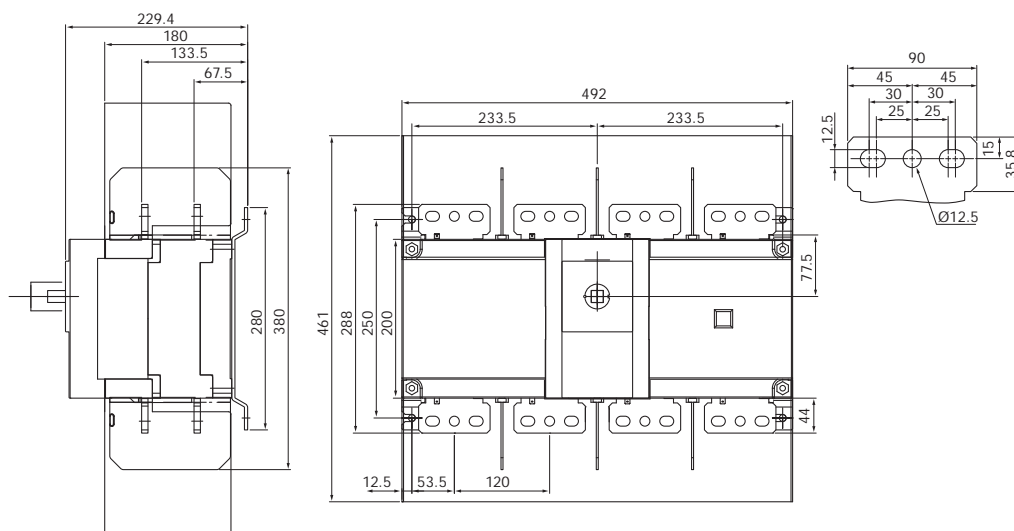

sirco-pv_147_a_1_x_cat.ai

100 to 315 A - B4_{DS} - 4P - 1000 VDC - 2 circuits

26PV 5010 - 26PV 5016 - 26PV 5025 - 26PV 5031

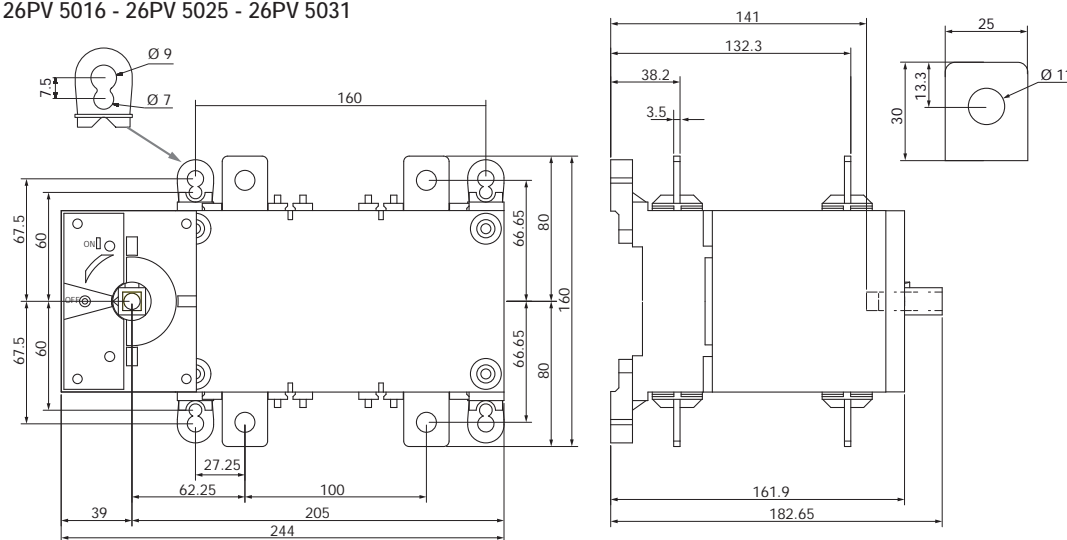

sirco-pv_148_a_1_x_cat.ai

630 A - B5_{DS} - 8P - 1000 VDC - 2 circuits

26PV 8063

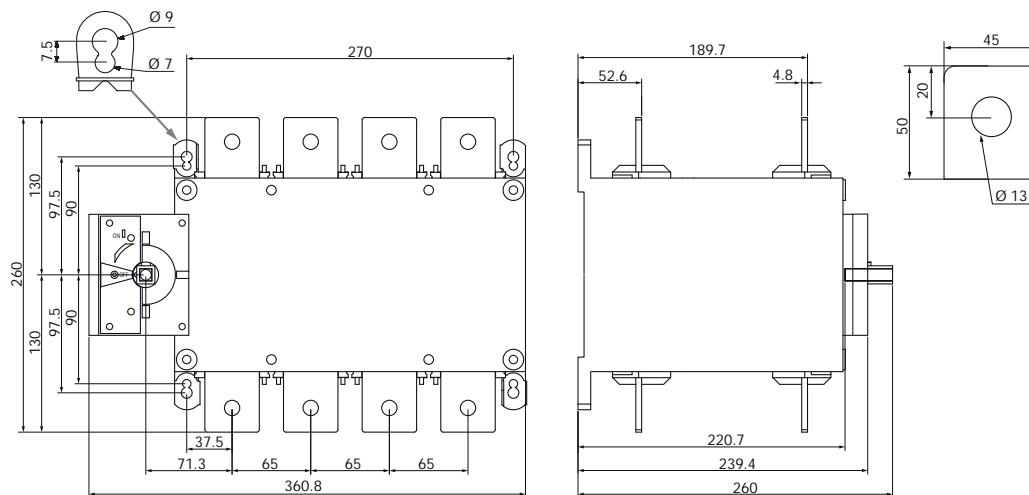

sirco-pv_150_a_1_x_cat.ai

800 A - B_{6DS} - 8P - 1000 VDC - 2 circuits

26PV 8080

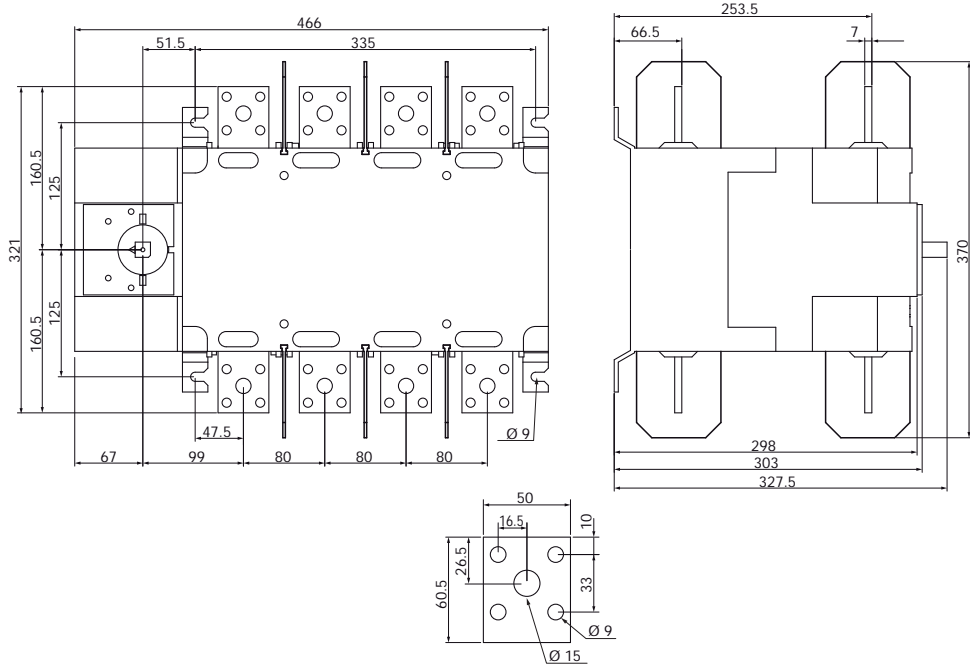

sirco-pv_151_a_1_x_cat.ai

1250 A - B_{6DS} - 8P - 1000 VDC - 2 circuits

26PV 8120

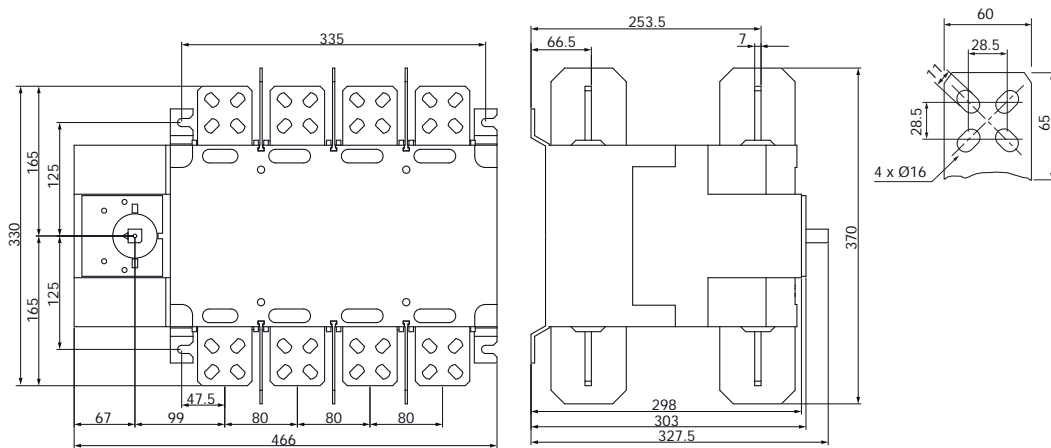

sirco-pv_152_a_1_x_cat.ai

SIRCO PV IEC 60947-3

Load break switches for photovoltaic applications
from 100 to 3200 A, up to 1500 VDC

Dimensions (mm) (continued)

2000 A - B7_{DS} - 8P - 1000 VDC - 2 circuits

26PV 8200

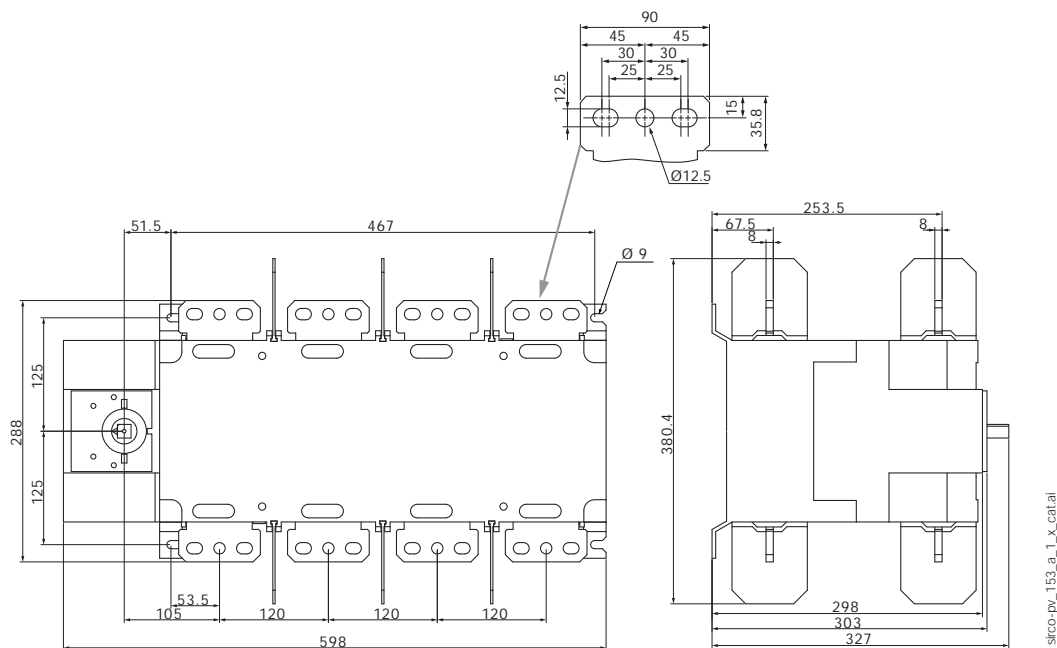

160 to 400 A - B4T - 3P - 1500 VDC - 1 circuit

26PV 3015 - 26PV 3024 - 26PV 3030 - 26PV 3039

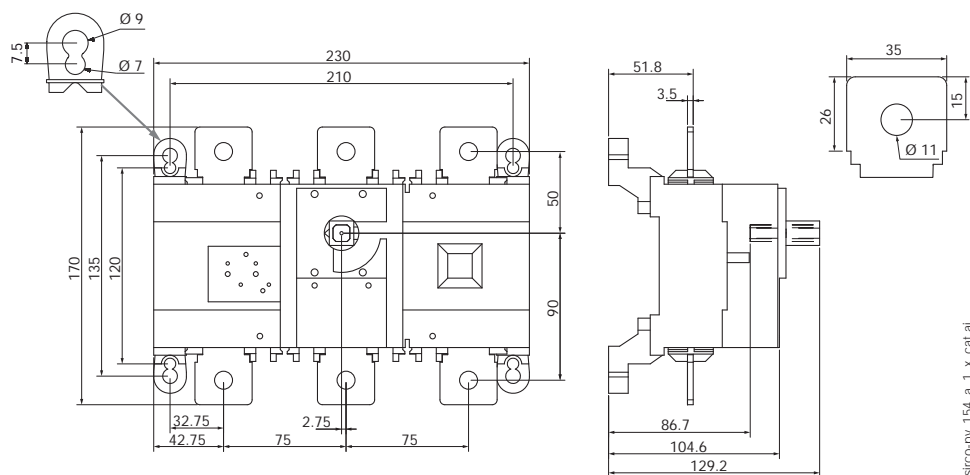

800 A - B6_{DS} - 8P - 1500 VDC - 1 circuit

26PV 8080

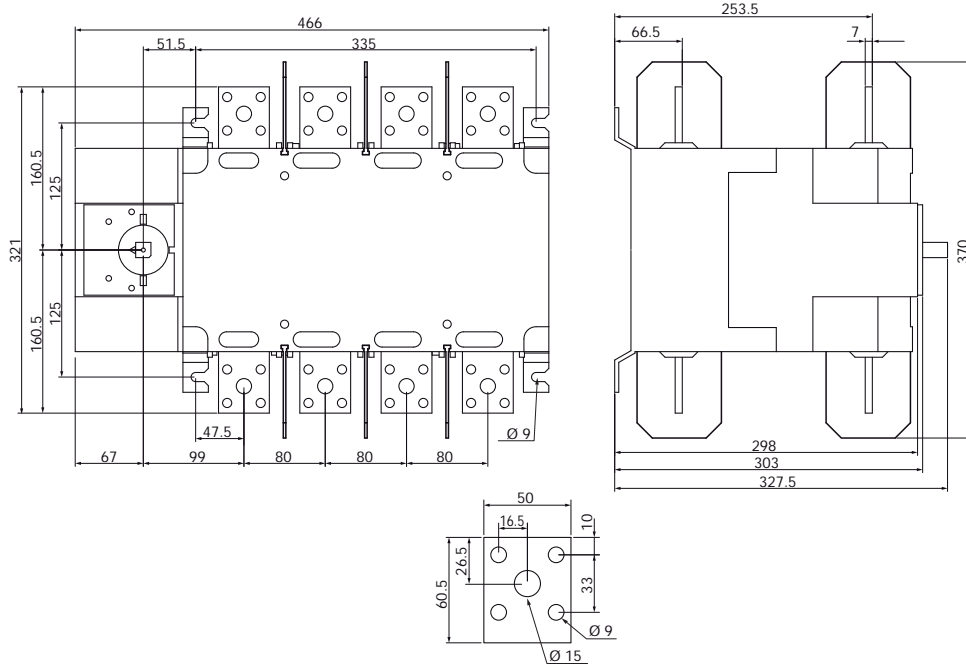

sirco-pv_151_a_1_x_cat.ai

1250 A - B6_{DS} - 8P - 1500 VDC - 1 circuit

26PV 8120

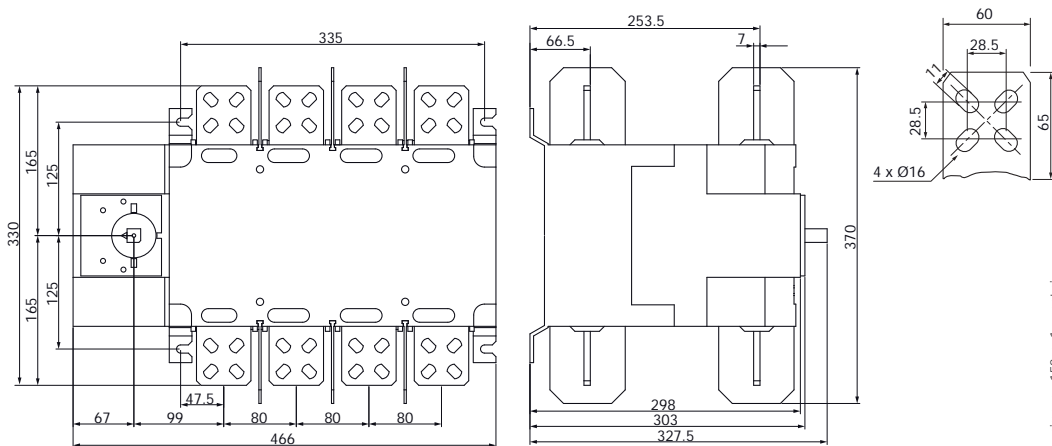

sirco-pv_152_a_1_x_cat.ai

SIRCO PV IEC 60947-3

Load break switches for photovoltaic applications
from 100 to 3200 A, up to 1500 VDC

Dimensions (mm) (continued)

2000 A - B7_{DS} - 8P - 1500 VDC - 1 circuit

26PV 8200

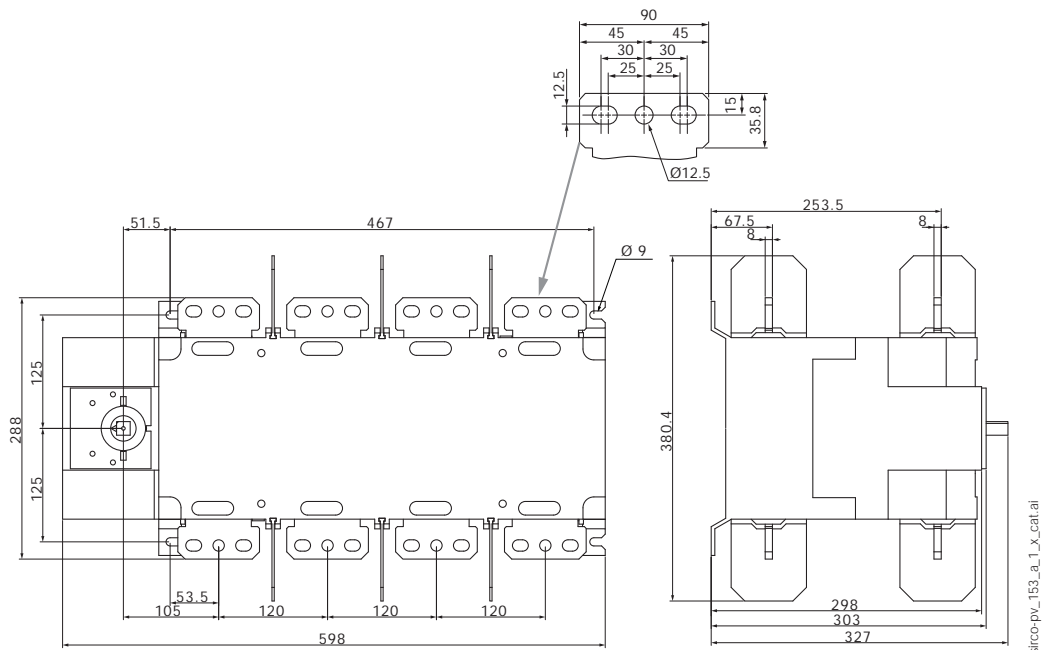

sirco-pv_163_a_1_x_cat.ai

Dimensions for external handles (mm)

B4 - B4_{DS} - B5

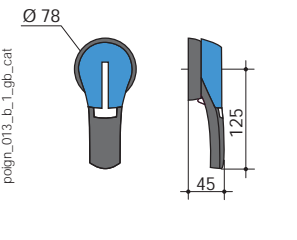
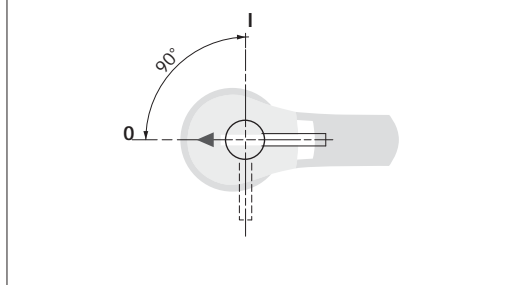
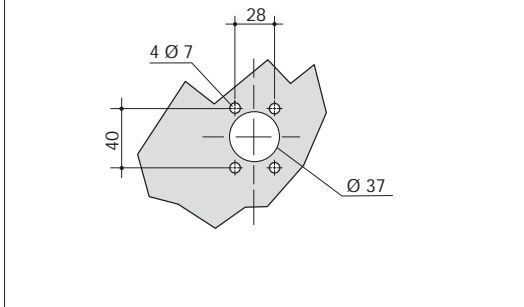
Handle type	Front operation Direction of operation	Door drilling
<p>S2 type</p>  <p>poign_013_b_1_gpb_cat</p>		

B5_{DS} - B6 - B7

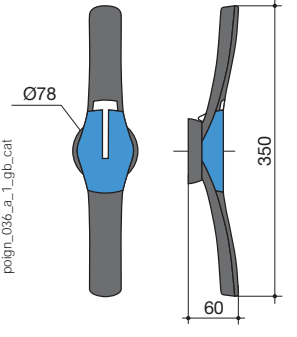
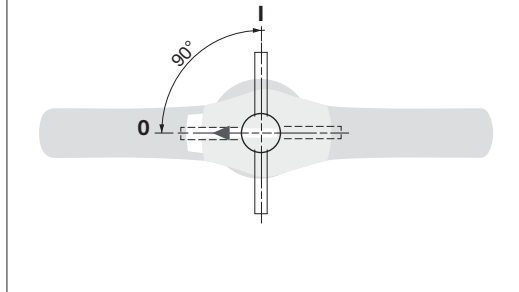
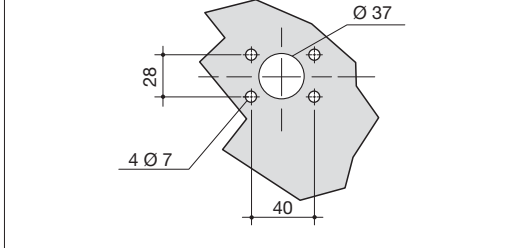
Handle type	Front operation Direction of operation	Door drilling
<p>S4 type</p>  <p>poign_036_a_1_gpb_cat</p>		

B8 - B6_{DS} - B7_{DS}

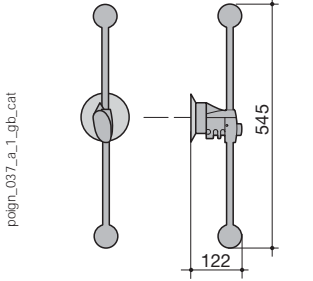
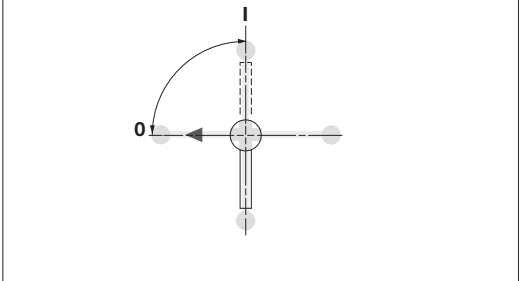
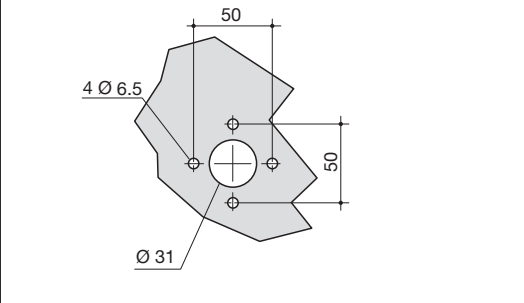
Handle type	Front operation Direction of operation	Door drilling
<p>V1 type</p>  <p>poign_037_a_1_gpb_cat</p>		

SIRCO PV IEC 60947-3

Load break switches for photovoltaic applications
from 100 to 3200 A, up to 1500 VDC

Bridging bars (mm)

2609 0025

siroco-ul_030_a_1_x_cat

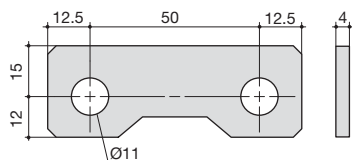

2709 0045

siroco-pv-134_a_1_x_cat

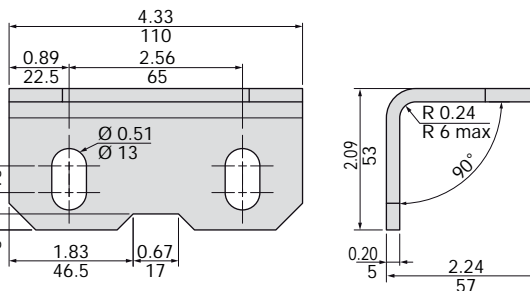

2709 0027

siroco-pv_179_a_1_x_cat

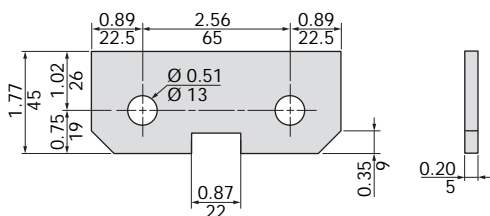

2609 0080

siroco-ul_031_a_1_x_cat

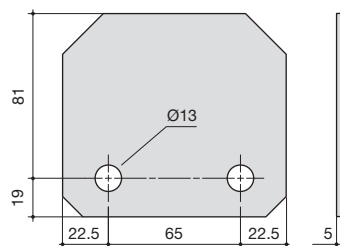

2609 0026

siroco-pv_140_a_1_x_cat

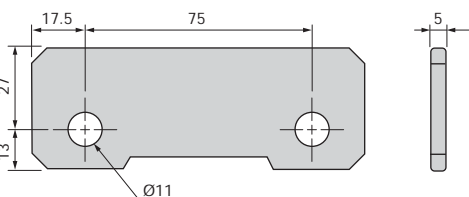

2609 1100

siroco-ul_032_a_1_x_cat

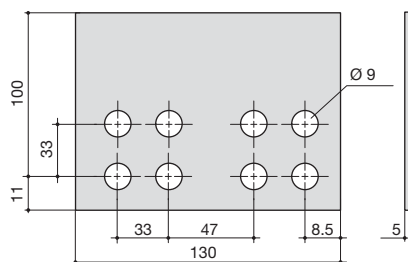

2609 1200

siroco-ul_034_a_1_x_cat

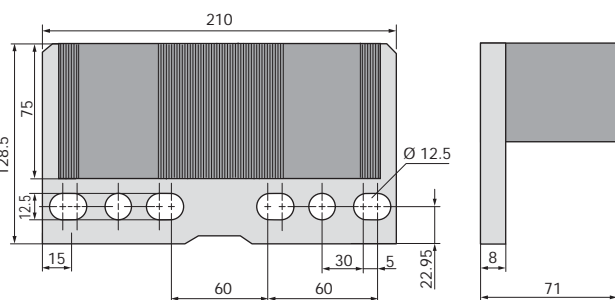

2609 0041

siroco-pv_181_a_1_x_cat

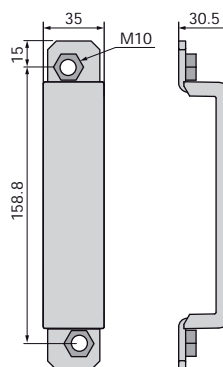

Mounting orientation

B4 to B8

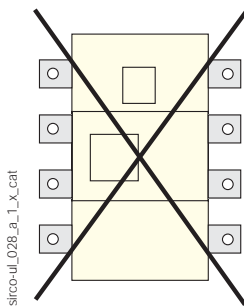
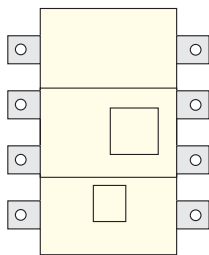
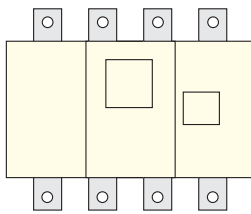
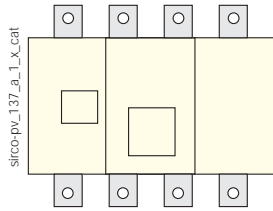

B4_{DS} - B5_{DS}

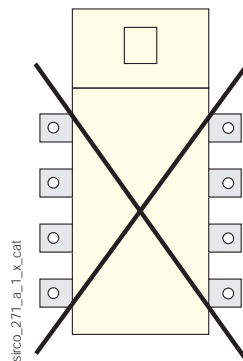
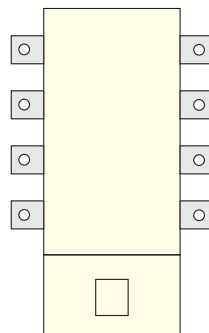
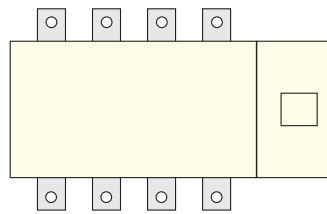
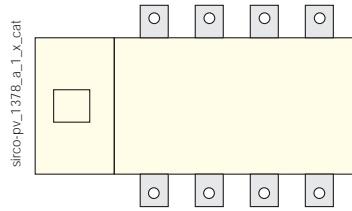

B6_{DS} - B7_{DS}

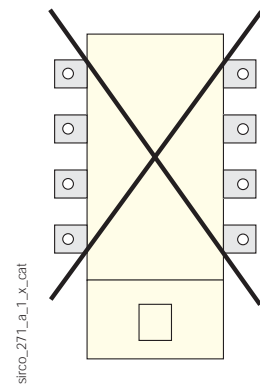
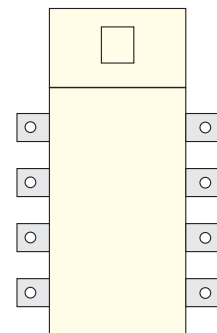
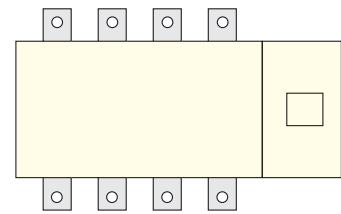
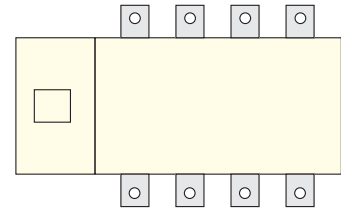

INOSYS LBS

Load break switches for DC and PV applications
160 to 630 A, up to 1500 VDC

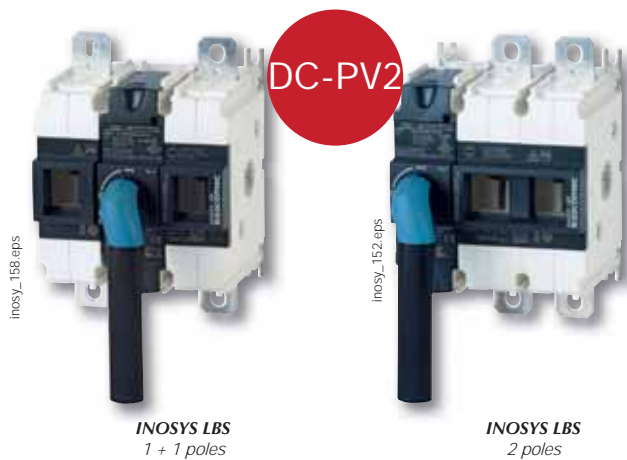

The solution for

- > Disconnection within PV installation
- > Battery protection
- > DC equipment & process isolation

Strong points

- > High-performance switching in a compact design
- > Easy integration
- > Reinforced safety with visible contact indication
- > Efficient with low power-loss

Compliance with standards

- > IEC 60947-3, DC-21B & DC-PV2



- > UL98B File E346418



- > KEMA-KEUR



- > CCC



Compatible with requirements

- > IEC 60364-7-712
- > NEC art. 690
- > AS/NZS 5033

Compliance with environmental standards

- > IEC 60947-1 Annex Q, Stage F
- > IEC 60068-2-1
- > IEC 60068-2-2
- > IEC 60068-2-27
- > IEC 60068-2-30
- > IEC 60068-2-52
- > IEC 60068-2-6



Functions

INOSYS LBS is a range of load break switches that can be manually controlled. These switches can be operated manually using the handle to disconnect all or part of the electrical installation. They ensure on-load opening / closing and safe disconnection of any low voltage electrical circuit up to 1500 VDC. They can also be used for emergency power switching applications. They are available for DC-PV2 utilization category.

Advantages

High performance power switching in confined spaces

INOSYS LBS load break switches incorporate patented technology that provides a breaking capacity of between 500 and 750 VDC per pole, providing 1500 VDC in just 2 poles, and significantly limiting power dissipation. All in an exceptionally compact enclosure.

Safe to use

- Direct position indicator on the bar and visible contact with containment of the electrical arc.
- The switch is completely independent of the operating speed, which ensures safe use under any conditions.
- High temperatures permitted: without derating up to 55 °C (131 °F), operational from -40 to +70 °C.

Designed for harsh environments.

- Vibration-tested (13.2 Hz to 100 Hz at 0.7 G).
- Impact-tested (15 g for three cycles).
- Humidity-tested (2 cycles, 55 °C, 95% humidity).
- Salt spray-tested (3 cycles with storage humidity, 40 °C, 93% humidity after each cycle).

Easy to install

- Wiring: the non-polarisation of the switch allows for all types of wiring and connections.
- Integrated auxiliary contacts.

Modular solution for flexible configuration

- Single or double-pole switch
The same switch can be used on earth-connected or insulated networks with a simple change in the wiring configuration.

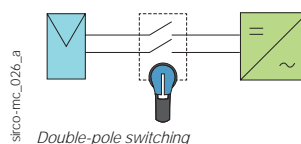
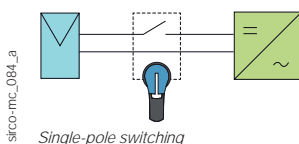

Typical applications: local safe disconnection for DC and PV applications

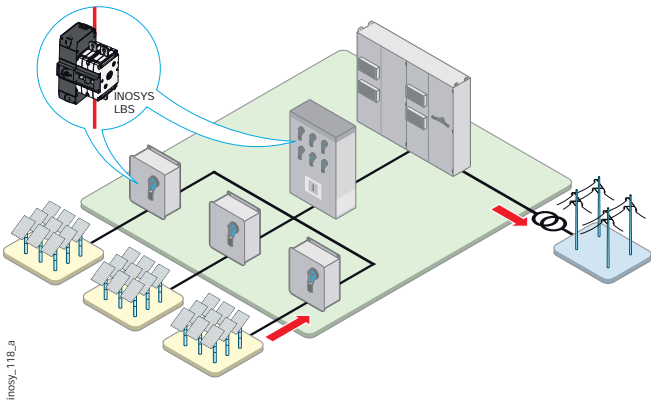
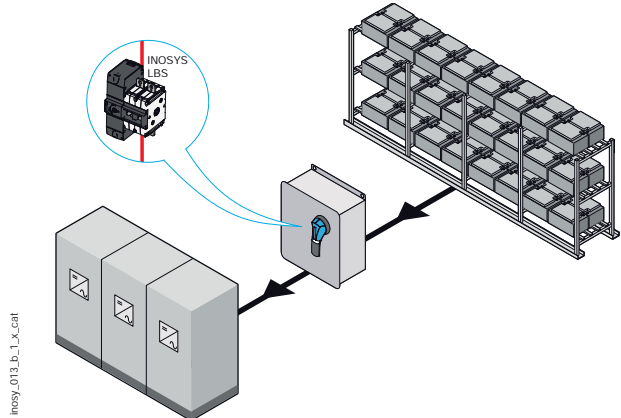
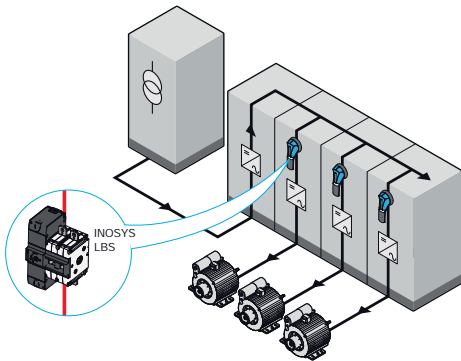
<p>PV system: Junction box, combiner box or inverter</p>  <p><small>inosy_118_a</small></p>	<p>Battery isolation</p>  <p><small>inosy_013_b_Lx_cdt</small></p>
<p>DC process isolation</p>  <p><small>inosy_014_b_Lx_cdt</small></p>	

The SOCOMEC solutions

<p>SIRCO PV Manual PV switches</p>  <p><small>sirco-pv_059 - 060 - 061</small></p> <p>Up to 3200 A at 1000 VDC Up to 2000 A at 1500 VDC Up to 4 circuits</p>	<p>INOSYS LBS Visible breaking switches for DC and PV applications</p>  <p><small>inosy_152</small></p> <p>Up to 630 A (IEC) and 600 A (UL) at 1500 VDC</p>
--	---

INOSYS LBS

Load break switches for DC and PV applications
160 to 630 A, up to 1500 VDC

Introduction



1. INOSYS LBS 400 A - 1500 V DC
2. External operation handle
3. Direct operation handle
4. Shaft for external operation
5. Auxiliary contact
6. Inter-phase barriers
7. Terminal shrouds
8. Terminal screen
9. Bridging bar to arrange the poles in series
10. Captive nut
11. Mounting insert
12. Cage terminals

REFDAM_inosy_148_a_1_x_cat.at

References

INOSYS LBS

1000 VDC - 1 circuit

Rating (A)	Frame size	No. of poles per circuit	Switch body ⁽¹⁾	External operation	Aux. Contact
160 A	F2	2 P (1 P+, 1 P-)	86P0 2016	Shaft 320 mm 1400 1032 Handle type S2 Black IP65 742F 2111	NO/NC 8499 0001
250 A	F2	2 P (1 P+, 1 P-)	86P0 2025		
315 A	F2	2 P (1 P+, 1 P-)	86P0 2031		
400 A	F3	2 P (1 P+, 1 P-)	86P0 2040	Shaft 320 mm 1400 1032 Handle type S2L Black IP65 14AF 2111	

(1) The switches are supplied without accessories.

(2) Please contact us

1500 VDC - 1 circuit

Rating (A)	Frame size	No. of poles per circuit	Switch body ⁽¹⁾	External operation	Aux. Contact
160 A	F2	2 P (1 P+, 1 P-)	86P0 2017	Shaft 320 mm 1400 1032 Handle type S2 Black IP 65 742F 2111	NO/NC 8499 0001
			86P1 1017 ⁽²⁾		
250 A	F2	3 P (2 P+, 1 P-)	86P0 3016		
			86P0 2026		
			86P1 1026 ⁽²⁾		
			86P0 3025		
315 A	F2	2 P (1 P+, 1 P-)	86P0 2032		
			86P1 1032 ⁽²⁾		
400 A	F3	3 P (2 P+, 1 P-)	86P0 3031		
			86P0 2041		
630 A	F3	2 P (1 P+, 1 P-)	86P1 1041 ⁽²⁾	Shaft 320 mm 1400 1032 Handle type S2L Black IP 65 14AF 2111	
			86P0 2064		
			86P1 1064 ⁽²⁾		

1500 VDC - 2 circuits

Rating (A)	Frame size	No. of poles per circuit	Switch body ⁽¹⁾	External operation	Aux. Contact
400 A	F3	2 P (1 P+, 1 P-)	86P2 2041 ⁽²⁾	Shaft 320 mm 1400 1032 Handle type S2L Black IP 65 14AF 2111	NO/NC 8499 0001
500 A			86P2 2051		
630 A			86P2 2064 ⁽²⁾		

(1) The switches are supplied without accessories.

(2) Centred mechanism.

Accessories

Direct operation handle

Frame size	Handle type	Handle colour	Reference
F2	E2	Black	8499 5022
F2	E2	Red	8499 5023
F3	E3	Black	8499 5032



E2 handle

access_400_a_1_cat

External operation handle

Use

The external control handles include a breastplate and can be padlocked. External handles should be used with a shaft extension.

Note: We recommend using IP55 for indoor and IP65 for outdoor applications.

Example of use:

When the handle is locked in the "ON" position, the operator must make sure to disconnect and isolate the circuit before accessing the board and carrying out maintenance work.

You can open the door when the switch is in the "ON" position by bypassing the lock function with a specially designed tool (authorised persons only). The lock is automatically re-applied when the door is closed.



Handle type S2

access_150_eps

Frame size	Handle type	Handle colour	Protection degree	Front operation Reference	Side operation Reference ⁽²⁾
F2	S2	Black	IP65	742F 2111	14YA 2111
F2	S2	Red	IP65	14AE 2111	
F3	S2L ⁽¹⁾	Black	IP65	14AF 2111	14AA 2111
F3	S2L ⁽¹⁾	Red	IP65	14AE 2111	

⁽¹⁾ S2L handles have an extended socket; please see the section on dimensions.

⁽²⁾ Only compatible with left mechanism version.

Shaft for external operation

Frame size	Handle type	Length (mm)	Reference
F2 - F3	S2, S2L	200	1400 1020
F2 - F3	S2, S2L	320	1400 1032
F2 - F3	S2, S2L	400	1400 1040

Other colour schemes: please contact us.



Shaft for S2 and S2L handles

access_401_a_1_cat

Shaft guide for external operation

Use

Allows you to guide the shaft for external control.

This accessory can correct any misalignment of the control shaft by up to 15 mm.

Recommended for shaft lengths over 320 mm.

Description	Reference
Shaft guide	1429 0000



access_260_a_2_cat

Auxiliary contact

Use

Provide information about the position and pre-break depending on installation location.

Characteristics

Switching type: NO/NC,
IP2X with front control (screw cap).
10 000 operations.
Max. 3 per switch.

Frame size	Connection type	Type	Reference
F2 - F3	Screws	Standard NO/NC	8499 0001
F2 - F3	Screws	Low level NO/NC	8499 0002

Characteristics

Type of auxiliary contact	Min. current (A)	I _{th} (A)	Operating current I _e (A)			
			24 VDC DC-14	48 VDC DC-14	230 VAC AC-15	440 VAC AC-15
Standard	12.5 mA / 24 V	16	1	0.2	4	4
Low level	1 mA / 4 V	16	1	0.2	2	1



access_402_a_1_cat

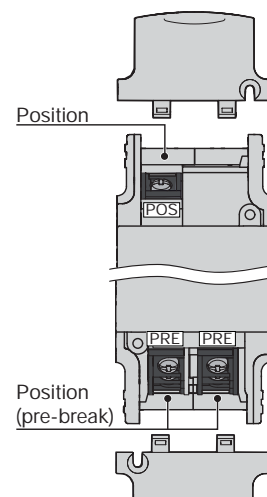

access_405_a_1_gb_cat

Bridging bar for poles in series

Use

The bridging bars enable the poles to be connected in series, allowing the following configurations.

1500 VDC – 1 circuit – dual polarity switching

Frame size	Rating (A)	No. of poles per circuit	Quantity to order	Reference
F2	160 ... 315	3 P	1	8409 0016 ⁽¹⁾

⁽¹⁾ Kit includes 2 identical bridging bars.

1500 VDC – 1 circuit with full voltage switching per polarity / 2 circuits – single polarity switching

Frame size	Rating (A)	No. of poles per circuit	Quantity to order	Reference
F3	400	4 P / 2 P	2	8409 0040 ⁽¹⁾
F3	500	4 P / 2 P	2	8409 0041
F3	630	4 P / 2 P	2	8409 0063

⁽¹⁾ Kit includes 2 identical bridging bars.

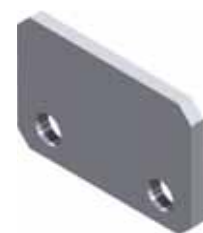

access_411_a_1_cat

INOSYS LBS

Load break switches for DC and PV applications

160 to 630 A, up to 1500 VDC

Accessories (continued)

Inter-phase barriers

Use

Safety isolating break between the terminals, essential for use at 1000 VDC and 1500 VDC or between 2 circuits.

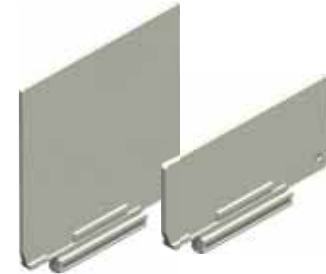

access_405_a_1_cat access_406_a_1_cat

Frame size	Type	Packaging (units)	Reference
F2 - F3	Short	2	8499 2202
F2 - F3	Short	3	8499 2203
F2 - F3	Long	2	8499 2212
F2 - F3	Long	3	8499 2213

Terminal shrouds

Use

For top or bottom protection against direct contact with terminals or connection parts; provides IP4 protection and phase separation. 1 P type to cover 1 pole connection.

Advantages

Perforations for thermographic inspection / voltage check without the need to remove the shrouds. Terminal shrouds can be fixed in place with a holding insert. Includes break-off tabs for precise adaptation to cables or insulated bars.



access_407_a_1_cat

Frame size	Packaging (units)	No. of poles	Position	Reference
F2	3	1 P	Top or bottom	8499 4213 ⁽¹⁾
F2	4	1 P	Top or bottom	8499 4214 ⁽¹⁾
F3	4	1 P	Top or bottom	8499 4314 ⁽¹⁾

⁽¹⁾ Compatible with the holding insert which can be fitted to lock the shrouds in place.

Terminal screens

Use

Provides top and bottom protection against direct contact with terminals or connection parts.

Advantages

Perforations for thermal checks. Assembly requires mounting inserts (provided with terminal screens).



access_408_a_1_cat

Frame size	No. of poles	Position	Reference ⁽¹⁾
F2	2 P	Top and bottom	8499 3222
F2	3 P	Top and bottom	8499 3232
F3	2 P	Top and bottom	8499 3322

⁽¹⁾ Each reference comprises 2 terminal screens for top and bottom protection.

Mounting insert

Use

Used to secure terminal shrouds / inter-phase barriers on the switch.

Frame size	Packaging (units)	Reference
F2 - F3	10	8499 6220
F2 - F3	100	8499 6221



aces_409_a_1_cat

Captive nut

Use

This accessory enables simple one-sided connection to the power terminals. It can be mounted on either side of the terminal for front or rear connection.

Frame size	Packaging (units)	Reference
F2	12	8499 6120
F2	120	8499 6121
F3	12	8499 6130
F3	120	8499 6131



aces_399_a_1_cat

Voltage tap

Use

Allows you to connect sensors or measure voltage with a fast-on connection.

Frame size	Packaging (units)	Reference
F2	12	8499 9012
F3	12	8499 9013



aces_412_a_1_cat

Characteristics

Characteristics according to IEC 60947-3

Rated current I_n		160 A	250 A	315 A	400 A	500 A	630 A
Frame size		F2	F2	F2	F3	F3	F3
Thermal current at 40 °C (A)		160	250	315	400	500	630
Thermal current at 50 °C (A)		160	250	315	400	500	630
Thermal current at 60 °C (A)		160	250	315	400	500	630
Rated insulation voltage U_i (V)		1500	1500	1500	1500	1500	1500
Rated impulse withstand voltage U_{imp} (kV)		12	12	12	12	12	12
Number of circuits	Nominal voltage	Utilisation category	I_e (A)	I_e (A)	I_e (A)	I_e (A)	I_e (A)
1 circuit	1000 VDC ⁽¹⁾	DC-21 B	160	250	315	400	500
1 circuit	1500 VDC ⁽²⁾	DC-21 B	160	250	315	400	500
Number of circuits	Nominal voltage	Utilisation category	I_e (A)	I_e (A)	I_e (A)	I_e (A)	I_e (A)
1 circuit	1000 VDC ⁽¹⁾	PV2	-	-	-	-	-
1 circuit	1500 VDC ⁽²⁾	PV2	160	250	315	400	500
2 circuits	1500 VDC ⁽²⁾	PV2	-	-	-	400	500
Short-circuit operation at 1000 VDC and 1500 VDC (unprotected)							
Current rated as short-time withstand I_{cw} 1s (kA rms)		5	5	5	8	8	8
Rated short-circuit breaking capacity I_{cm} (peak kA) – 60 ms		10	10	10	10	10	10
Connection							
Recommended Cu rigid cable cross-section ⁽³⁾		70	120	185	240	2 x 150	2 x 185
Recommended width of copper bars (mm) ⁽³⁾		20	20	20	25	25	25
Mechanical characteristics							
Durability (number of operating cycles)		8000	8000	8000	8000	8000	8000
Power dissipation per pole (W/pole)		4.5	11.2	13	13	21.6	30.2

(1) 2 poles in series.

(2) 2 or 3 poles in series.

(3) For aluminium connections, please contact us.

Dimensions (in/mm)

INOSYS LBS

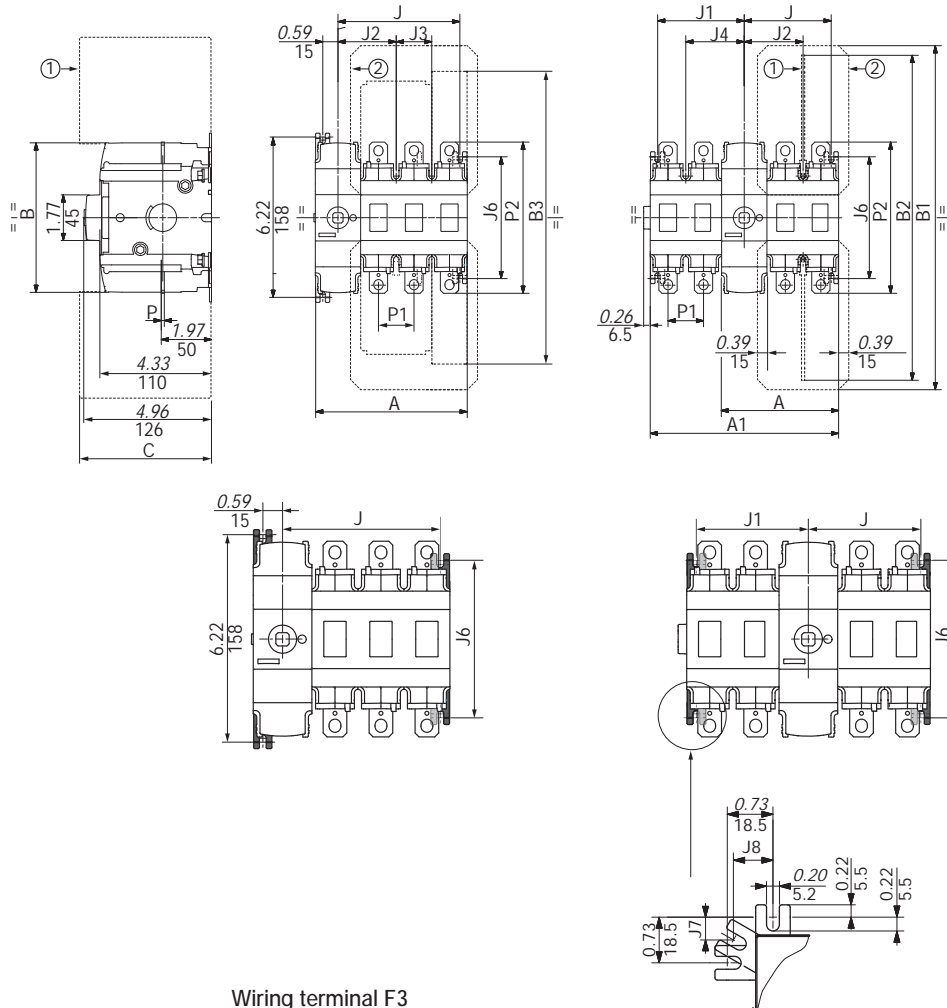

Wiring terminal F2

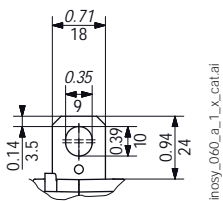

inosy_060_a_1_x_catal

Wiring terminal F3

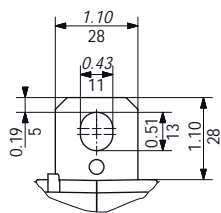

inosy_061_a_1_x_catal

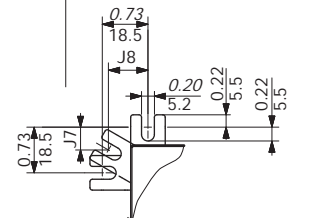

inosy_166_a_1_x_catal

Rating (A)	Frame size	Units	A		A1	J	J1	J	
			2 P	3 P	1+1 P / 2+2 P	1+1 P / 2+2 P	1+1 P / 2+2 P	2 P	3 P
160 ... 315	F2	inches	4.60	5.98	4.60 / 7.36	1.97 / 3.37	2.05 / 3.44	3.35	4.72
		mm	117	152	117 / 187	50.5 / 85.5	52.5 / 87.5	85.5	120.5
400	F3	inches	5.40	7.17	5.40 / 8.94	2.36 / 4.15	2.44 / 4.23	4.13	-
		mm	137	182	137 / 227	60.5 / 105.5	62.5 / 107.5	105.5	-

Rating (A)	Frame size	Units	B	B1	B2			B3	C		J2	J3	J4	J6	P1	P2
			IEC short	IEC long	UL	IEC	UL									
160 ... 315	F2	inches	5.90	13.35	7.85	12.61	10.31	11.64	4.33	4.33	2.26	1.38	2.34	4.72	1.38	5.87
		mm	154	339	199	320	262	296	110	110	57.5	35	59.5	120	35	149
400	F3	inches	5.90	16.28	9.35	14.11	15.5	14.12	4.33	5.31	2.64	1.77	2.72	6.22	1.77	7.87
		mm	154	414	237	358	394	359	110	135	67.5	45	69.5	158	45	200

Dimensions of external handles (in/mm)

F2

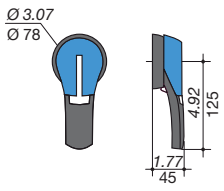
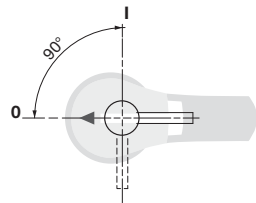
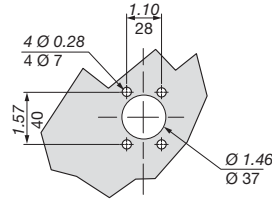
Handle type	Front operation Direction of operation	Door drilling
S2 type 		

poign_013_b_1_us_cat.eps

F3

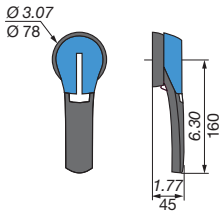
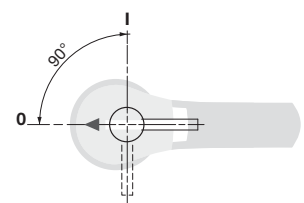
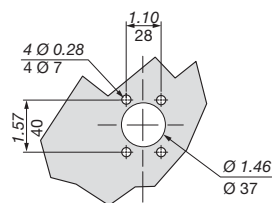
Handle type	Front operation Direction of operation	Door drilling
S2L type 		

poign_069_b_1_us_cat.eps

Wiring configuration

1 circuit - 1000 VDC

F2-F3 - 2 P

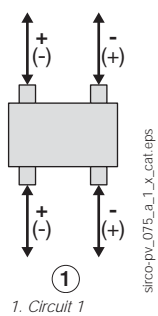

1 circuit - 1500 VDC

F2 - 3 P

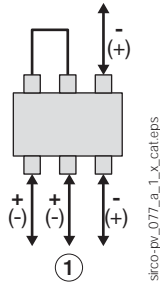

2 circuits - 1500 VDC

F2-F3 - 2 P

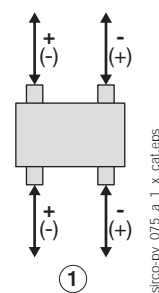

F3 - 2 P

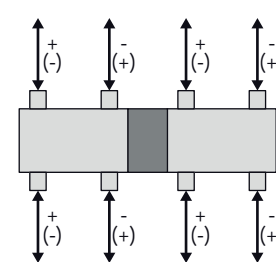

1 circuit - 1500 VDC per polarity

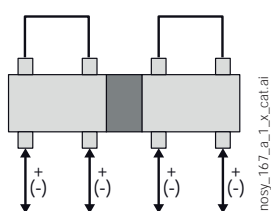

Bridging bars (in/mm)

F2

8409 0016⁽¹⁾

⁽¹⁾ Kit includes 2 identical bars.

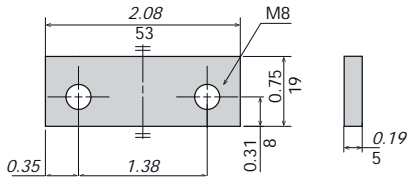

F3

8409 0040⁽¹⁾

⁽¹⁾ Kit comprises 2 identical bars.

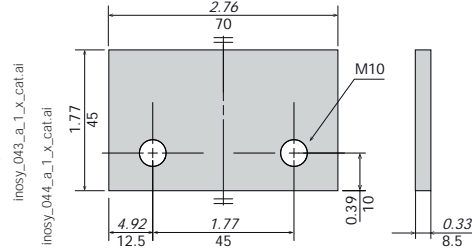

F3

8409 0041

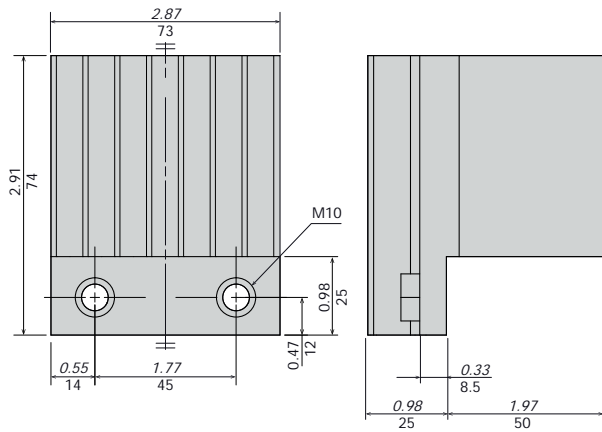

8409 0063

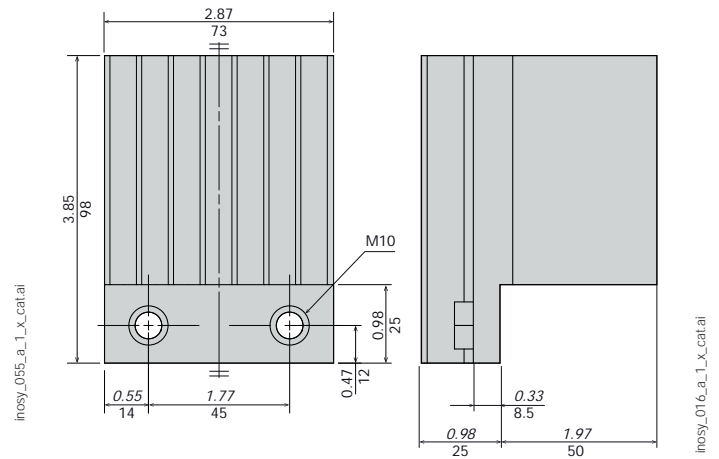

Mounting orientation

F2 - F3

All mounting orientations are possible. Derating may apply - please consult us.



SIRCO MOT DC/SIRCO MOT DC ESS

Motorised load break switches for DC applications

from 250 to 3600 A, up to 1500 VDC



SIRCO MOT DC
4 x 2000 A

The solution for

- > Photovoltaic inverters and recombiner boxes (PV)
- > Energy Storage System (ESS)
- > Rail Infrastructure
- > Marine Distribution and microgrids
- > Data centre



Strong points

- > High performance switching
- > Application tested design
- > Reduced total cost of ownership

Conformity to standards

- > IEC 60947-3
- > GB/T 14048.3
- > UL 98B



Function

SIRCO MOT DC and SIRCO MOT DC ESS motorised load break switches incorporate patented technology, providing a breaking capacity at 1500 VDC with just 2 poles, significantly limiting power dissipation. This broad range covers ratings from 250 to 3600 A, 1500 VDC.

Advantages

High performance switching

SIRCO MOT DC and SIRCO MOT DC ESS motorised load break switches incorporate patented technology, providing a breaking capacity at 1500 VDC with just 2 poles, significantly limiting power dissipation. This broad range covers ratings from 250 to 3600 A, 1500 VDC.

Application tested design

Designed and tested for several DC applications, with proven performance in the harshest of environments. The arc extinguishing system provides safe disconnection, rapid arc extinguishing and current interruption.

- Tested against high short circuit systems with and without fuse protection to ensure complete system protection above 210 kA.
- Proven against severe environmental factors including: "Annex Q level C according to IEC" salt spray tested, high temperature and altitude, humidity cycle tested.

Reduced total cost of ownership

Developed with user cost savings in mind, the product features improvements which ensure a lower total cost of ownership.

- Flexible wiring configurations allow for simple in and out wiring, and by not using series bridging bars, cost savings can be achieved.
- Multiple circuit design allows for configurations of one 3600 A or two 1600 A circuits for greater flexibility.
- One design for both IEC and UL products providing the same base design for customers with IEC or UL machines.
- Compact solution with reduced footprint and weight improves sustainability with reduced packaging, transportation and installation costs.

General characteristics

- Up to 1500 VDC from 250 to 3600 A.
- Patented switching technology up to 1500 VDC in 2 poles.
- Remotely operated product (motor control).
- 2 stable positions (I, 0).
- High short-circuit option available.

SIRCO MOT DC/SIRCO MOT DC ESS

Motorised load break switches for DC applications

from 250 to 3600 A, up to 1500 VDC

References

1000 VDC

Rating (A) / Frame size	No. of poles No. of circuits	Switch body	Bridging bars for series or parallel pole connection ⁽¹⁾	Inter phase barrier ⁽²⁾
250 A / B4	4 P 1 circuit	19PV 4025	2609 2025	2998 0024
400 A / B4		19PV 4038	2609 2025	2998 0024
630 A / B5		19PV 4064	2609 0080	2998 0014
1000 A / B6		19PV 4100	2609 1100	Included
1250 A / B6		19PV 4120	2609 1100	
1600 A / B7		19PV 4160	2609 1160	
2000 A / B7		19PV 4200	2609 1160	

(1) Bridging bars only connect 2 poles in series, see wiring diagram for amount of series connections required

(2) Interphase barriers are in sets for top or bottom side. If both required, order two sets.

1500 VDC

Rating (A) / Frame size	No. of poles No. of circuits	Switch body	Bridging bars for series or parallel pole connection ⁽¹⁾	Inter phase barrier ⁽²⁾
250 A / B5	3 P 1 circuit	19PV3026	2609 0027	2998 0024
400 A / B5		19PV3041	2609 0027	2998 0024
630 A / B5	4 P 1 circuit	19PV4064	2609 0027	2998 0014
1000 A / B6ds	6 P 1 circuit	19PV6101	2609 1100 4109 0120 ⁽¹⁾	
2 x 1600 A / B7ds	4P 2 circuit	18DC4360	-	
2000 A / B7ds	4 P 1 circuit	18DC4200	1909 0001	Not Required
2000 A / B7ds (UL)		19DC4200	1909 0001	Not Required
2500 A / B7ds		18DC4250	1909 0001	Not Required
3200 A / B7ds		18DC4320	1909 0001	Not Required
3600 A / B7ds		18DC4360	1909 0001	Not Required

(1) Bridging bars only connect 2 poles in series, see wiring diagram for amount of series connections required

(2) Interphase barriers are in sets for top or bottom side. If both required, order two sets.

1500 VDC High Short Circuit

Rating (A) / Frame size	No. of poles No. of circuits	Switch body	Bridging bars for connecting poles in series ⁽¹⁾	Inter phase barrier ⁽²⁾
2 x 1600 A / B7ds	4 P 2 circuit	18ES4360	-	
2000 A / B7ds	4 P 1 circuit	18ES4200	1909 0001	Not Required
2000 A / B7ds (UL)		19ES4200	1909 0001	Not Required
2500 A / B7ds		18ES4250	1909 0001	Not Required
3200 A / B7ds		18ES4320	1909 0001	Not Required
3600 A / B7ds		18ES4360	1909 0001	Not Required

(1) Bridging bars only connect 2 poles in series, see wiring diagram for amount of series connections required

(2) Interphase barriers are in sets for top or bottom side. If both required, order two sets.

SIRCO MOT DC/SIRCO MOT DC ESS

Motorised load break switches for DC applications

from 250 to 3600A, up to 1500 VDC

Accessories

Bridging bars

Use

The bridging bars will make easy the connection of poles in series or parallel, allowing the following configurations:

- Bottom/Bottom
- Top/Top

- Top/Bottom

- Bottom/Top

Connection diagrams: see "Pole series connections".



Bridging bar 250 A

access_334_a_1_cat

Rating (A) /Frame size	Number of poles of the device in series	Pack	Reference
250 ... 400 / B4	2	2 pieces	2609 2025
630 ... 800 / B5			2609 0080
1000 ... 1250 / B6			2609 0027
1000 / B6ds	3	1 piece	2609 1100 4109 0120
1600 ... 2000 / B7	2	2 pieces	2609 1160
2000 (UL) / B7ds ⁽¹⁾	2	1 piece	1909 0001
up to 3600 / B7ds ⁽²⁾	2		1909 0001

(1) UL B7ds requires 4 pcs (2) IEC B7ds requires 8 pcs



Bridging bar 2000 ... 3200 A

access_392_a_1_cat

Auxiliary contact

Use

Pre-break and signalisation of position I:

1 to 2 NO/NC auxiliary contacts

(1 as standard).

Low level auxiliary contacts: please consult us.

Connection to the control circuit

By 6.35 mm fast-on terminal.

Electrical characteristics

30 000 operations.

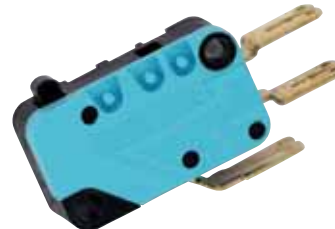

access_065_a_1_cat

Characteristics

Rating (A)	Nominal current (A)	Operating current I _e (A)			
		250 VAC AC-13	400 VAC AC-13	24 VDC AC-13	48 VDC AC-13
250 ... 3200	16	12	8	14	6

References

NO/NC changeover contact

Frame size	Rating (A)	Contact(s)	Reference
B4 ... B5	250 ... 800	2 nd	1999 1002
B6 ... B7	1000 ... 2000	2 nd	1999 1032
B7ds	1600 ... 3200	2 nd	1999 1032



svr_058_a_1_cat

Terminal screens

Use

Top and bottom protection against direct contact with terminals or connection parts.

Frame size	Rating (A)	No. of poles	Position	Reference
B4	250 ... 400	4 P	top or bottom	1509 4025
B5	630 ... 800	4 P	top or bottom	1509 4063
B6	1000 ... 1250	4 P	top or bottom	1509 4080
B7	1600 ... 2000	4 P	top or bottom	1509 4160



access_207_a_2_cat

Accessories (continued)

Available for selected 1000 VDC products, contact us for specific requirements

Inter phase barrier

Use

Safety isolation between the terminals. For SIRCO MOT DC, the inter phase barriers allow insulation between pole connected in series.

Frame size	Rating (A)	No. of poles	Pack	Reference
B4	250 ... 400	4 P	3 pieces	2998 0024
B5	630 ... 800	4 P	3 pieces	2998 0014
B6 ... B8	1000 ... 3200	4 P	-	included

Available for selected 1000 vdc products, contact us for specific requirements



access_036_a_2_cat

Terminal shrouds

Use

Protection against direct contact with terminals or connecting parts.
Not compatible for terminals with bridging bars connected.

Advantage of terminal shrouds

Perforations allow remote thermographic inspection without the need to remove the shrouds.

Frame size	Rating (A)	No. of poles	Position	Reference
B4	250 ... 400	4 P	top or bottom	2694 4021
B5	630 ... 800	4 P	top or bottom	2694 4051



access_206_a_2_cat

2 position padlocking (I - 0)

Use

Enables padlocking in position I (product can be padlocked in position 0 as standard).
Factory fitted.

Frame size	Rating (A)	Reference
B4 ... B5	250 ... 800	9599 0003
B6 ... B8	1000 ... 3200	9599 0004



atvs_B54_a_1_cat

SIRCO MOT DC/SIRCO MOT DC ESS

Motorised load break switches for DC applications

from 250 to 3600A, up to 1500 VDC

Accessories (continued)

Key handle interlocking system

Use

Motorised and manual operations can be locked in position 0 using a RONIS EL11AP lock.

Factory fitted.

As standard, locking in position 0.
Optional padlocking in 2 positions:
Locking in position 0 and I.



a1ys_853_a_1_cat

Frame size	Rating (A)	Reference
B4 ... B5	250 ... 800	9599 1006
B6 ... B8	1000 ... 3200	9599 1004

Double power supply - DPS

Use

Allows a SIRCO MOT to be supplied by two 230 VAC, 50/60 Hz networks.

Input

- The input is considered "active" from 200 VAC.
- Maximum voltage: 288 VAC.
- Internal protection: each input is fuse protected 3.15 A.
- Connection on terminals: max. 6 mm².
- Modular device: 4 module width.

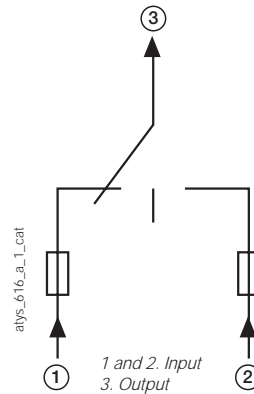

a1ys_612_a_2_cat

Description of accessories	Reference
DPS	1599 4001

Mounting spacers

Use

Increases the distance between the rear power terminals and the backplate by 10 mm.

This accessory may also be used to replace the original mounting spacers.



a1ys_009_a_2_cat

Frame size	Rating (A)	Description of accessories	Reference
B3 ... B5	125 ... 630	1 set of 2 spacers	1509 0001

Door protective surround

Use

When direct access to the SIRCO MOT front face (mode selection, manual operation, display...) is required, the door surround can be utilised to provide a clean and safe finish to the panel's cut-out.



a1ys_595_a_2_cat

Frame size	Rating (A)	Reference
B3 ... B5	125 ... 630	1529 0012
B6 ... B8	800 ... 3200	1529 0080

Characteristics according to IEC 60947-3

250 A to 2000 A at 1000 VDC

Thermal current I_{th} at 40°C*	250	400	630	1000	1250	1600	2000
Rated voltage	(A)	(A)	(A)	(A)	(A)	(A)	(A)
Rated insulation voltage U_i (V)	1200	1200	1200	1200	1200	1200	1200
Rated impulse withstand voltage U_{imp} (kV)	12	12	12	12	12	12	12
Frame size	B4	B4	B5	B6	B6	B7	B7

* For higher ambient temperature values, consult us

Thermal current I_{th} at 40°C*	250	400	630	1000	1250	1600	2000		
Rated voltage	(A)	(A)	(A)	(A)	(A)	(A)	(A)		
	Utilisation category	Ambient temperature (°C)							
1000 VDC	DC-21 B	40	250	400	630	1000	1250	1600	2000
1000 VDC	DC-21 B	50	250	400	630	1000	1250	1600	1800
1000 VDC	DC-21 B	60	250	400	560	1000	1125	1600	1600
1000 VDC	DC-21 B	70	250	400	540	950	1050	1520	1520

Short circuit capacity

Rated short time withstand current I_{cw} 1s (kA rms)	IEC 60947-3	10	10	10	10	10	10	10	10
Rated short-circuit making capacity I_{cm} (kA peak)	IEC 60947-4	10	10	10	10	10	10	10	10

* For Rated conditional short-circuit current I_q : Please consult us.

Power Supply

Power supply, 230 VAC min. / max. (VAC)	166/332	166/332	166/332	166/332	166/332	166/332	166/332
---	---------	---------	---------	---------	---------	---------	---------

Control supply power demand

Power supply 230 VAC inrush / nominal (VA)	276/115	276/116	176/150	460/184	460/184	460/230	460/230
--	---------	---------	---------	---------	---------	---------	---------

Connection

Rigid Cu cable cross-section (mm ²)	120	240	2 x 185	2 x 240	2 x 240	-	-
Maximum Cu busbar width (mm)	32	32	50	63	63	100	100
Tightening torque min/max (Nm)	20/26	40/45	40/45	40/45	40/45	40/45	40/45

Mechanical characteristics

Durability (number of operating cycles) ⁽¹⁾	8000	5000	5000	4000	4000	3000	3000
Weight of a 4 pole device (kg)	7	8	14	33	33	42	42

(1) Improved endurance; please consult us.

SIRCO MOT DC/SIRCO MOT DC ESS

Motorised load break switches for DC applications

from 250 to 3600A, up to 1500 VDC

Characteristics according to IEC 60947-3

250 A to 3600 A at 1500 VDC

Thermal current I_{th} at 40°C*	250	400	630	1000	2 x 1600	2000	2500	3200	3600
Rated voltage	(A)	(A)	(A)	(A)	(A)	(A)	(A)	(A)	(A)
Rated insulation voltage U_i (V)	1500	1500	1500	1500	1500	1500	1500	1500	1500
Rated impulse withstand voltage U_{imp} (kV)	12	12	12	12	12	12	12	12	12
Frame size	B5	B5	B5	B6	B7ds	B7ds	B7ds	B7ds	B7ds

Thermal current I_{th} at 40°C*	250	400	630	1000	2 x 1600	2000	2500	3200	3600		
Rated voltage	(A)	(A)	(A)	(A)	(A)	(A)	(A)	(A)	(A)		
Utilisation category											
Ambient temperature (°C)											
1500 VDC	DC-21 B	40	250	400	630	1000	2 x 1600	2000	2500	3200	3600
1500 VDC	DC-21 B	50	250	400	600	1000	2 x 1600	2000	2500	3200	3500
1500 VDC	DC-21 B	60	250	400	537	988	2 x 1400	2000	2500	3200	3200
1500 VDC	DC-21 B	70	250	360	470	862	2 x 1200	2000	2500	2900	2900

Short circuit capacity

Rated short time withstand current I_{cw} 1s (kA rms)	IEC 60947-3, GB/T 14048.3	10	10	10	10	20	45	45	45	45
Rated short-circuit making capacity I_{cm} (kA peak)	IEC 60947-3, GB/T 14048.3	10	10	10	10	20	45	45	45	45

* for higher ambient temperature values, consult us

Short circuit capacity (ESS range)

Rated conditional short-circuit current I_q (kA rms)	IEC 60947-3, GB/T 14048.3	-	-	-	-	105	210	210	210	210
--	---------------------------	---	---	---	---	-----	-----	-----	-----	-----

Power Supply

Power supply: 230 VAC min. / max. (VAC)	166/332	166/332	166/332	166/332	166/332	166/332	166/332	166/332	166/332	166/332
---	---------	---------	---------	---------	---------	---------	---------	---------	---------	---------

Control supply power demand

Power supply 230 VAC inrush / nominal (VA)	276/115	276/116	176/150	460/184	460/184	460/230	460/230	460/230	460/230
--	---------	---------	---------	---------	---------	---------	---------	---------	---------

Connection

Rigid Cu cable cross-section (mm ²)	120	240	2 x 185	-	-	-	-	-	-
Maximum Cu busbar width (mm)	32	40	40	63	63	100	100	100	100
Tightening torque min/max (Nm)	40/45	40/45	40/45	40/45	40/45	40/45	40/45	40/45	40/45

Mechanical characteristics

Durability (number of operating cycles)	8000	5000	5000	4000	6500	6500	6500	6500	6500
Weight of a 4 pole device (kg)	13	13	15	37	34	34	34	34	34

Characteristics according to UL 98B and IEC 60947-3

2000 A at 1500 VDC (B7ds UL)

Thermal current I_{th} at 40°C*	Utilisation category	Ambient temperature (°C)	2000						
Rated voltage			(A)						
1500 VDC	UL 98B	40	2000	-	-	-	-	-	-
1500 VDC	DC-21 B	40	-	-	-	-	-	-	3200
1500 VDC	DC-21 B	50	-	-	-	-	-	-	3200
1500 VDC	DC-21 B	60	-	-	-	-	-	-	3200
1500 VDC	DC-21 B	70	-	-	-	-	-	-	2900

* For higher ambient temperature values, consult us

Short circuit capacity

Prospective short-circuit current (kA rms DC) (kA rms)	UL 98B	-	-	-	-	-	10	-	-	-
--	--------	---	---	---	---	---	----	---	---	---

Short circuit capacity (ESS range)

Rated conditional short-circuit current I_q (kA rms)	IEC 60947-3, GB/T 14048.3	-	-	-	-	-	210	-	210	-
--	---------------------------	---	---	---	---	---	-----	---	-----	---

SIRCO MOT DC/SIRCO MOT DC ESS

Motorised load break switches for DC applications
from 250 to 3600 A, up to 1500 VDC

Dimensions (mm)

250 to 630 A / B4 to B5 / 1000 VDC

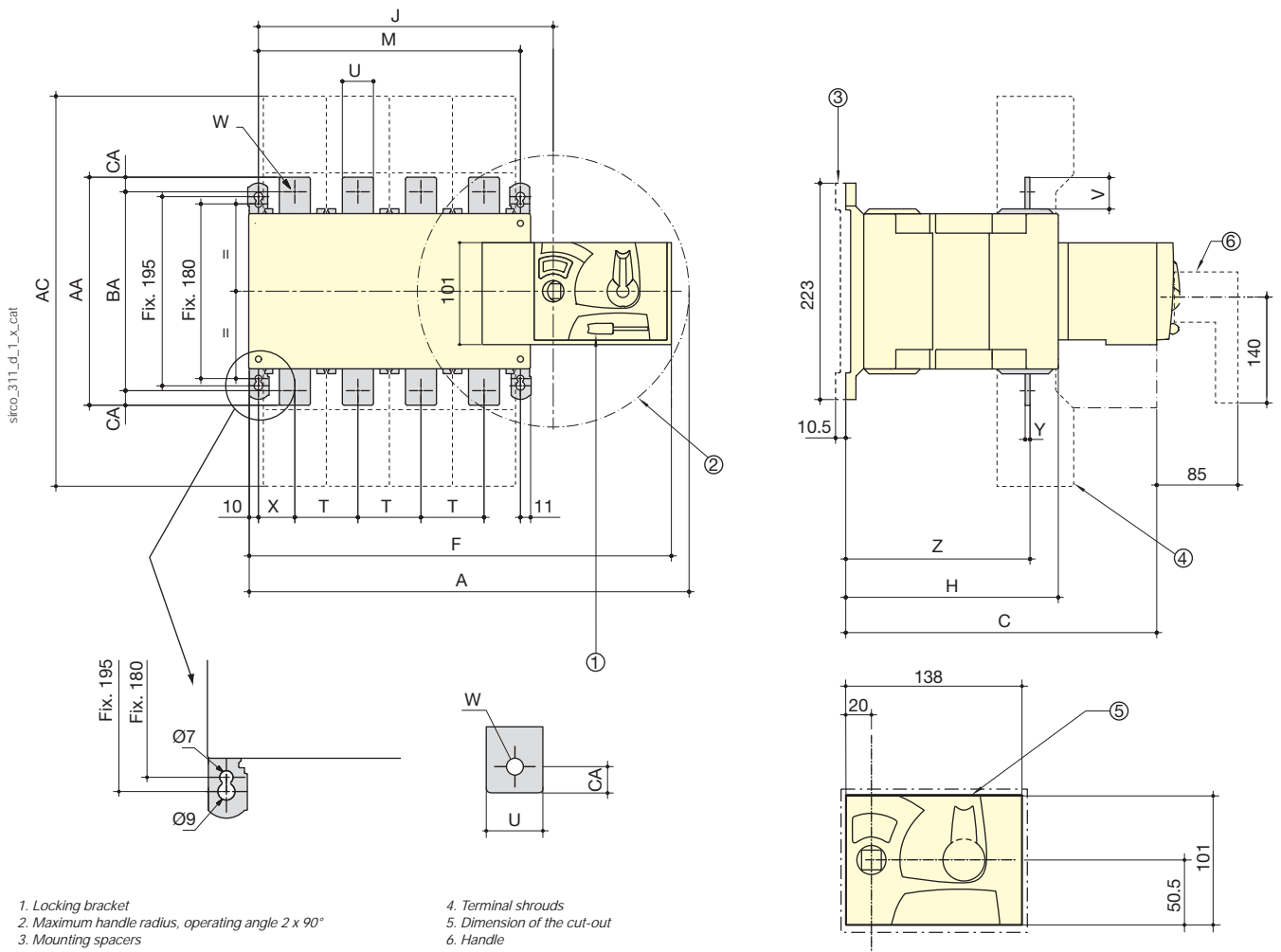

Rating (A) / Frame size	Overall dimensions		Terminal shrouds	Switch body			Switch mounting	Connection									
	A 4p.	C	AC	F 4p.	H	J	M 4p.	T	U	V	W	X 4p.	Y	Z	AA	BA	CA
250 / B4	395	244.5	280	378	153	245	210	50	25	30	11	33	3.5	134.5	160	130	15
400 / B4	395	244.5	280	378	153	245	210	50	35	35	11	33	3.5	134.5	170	140	15
630 / B5	459	320.5	400	437	221	304	270	65	45	50	13	37.5	5	190	260	220	20

SIRCO MOT DC/SIRCO MOT DC ESS

Motorised load break switches for DC applications

from 250 to 3600A, up to 1500 VDC

Dimensions (continued)

1000 to 2000 A / B6 to B7 / 1000 VDC

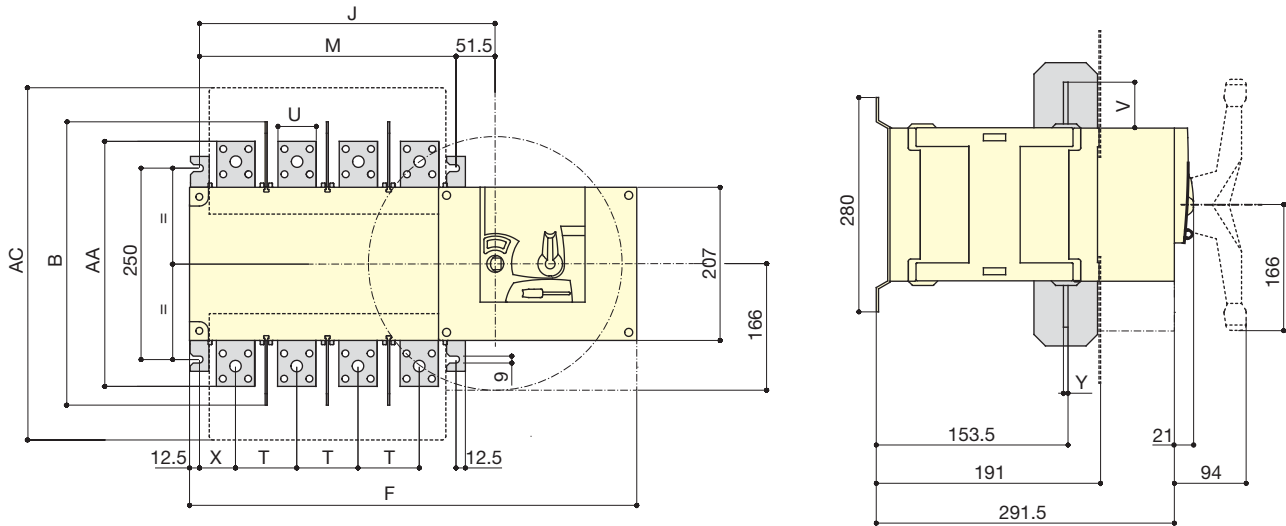

sifco-pv_109_b_1_x_cat

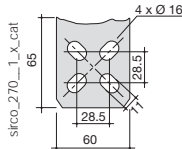
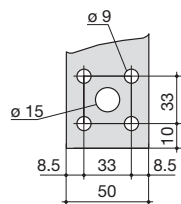
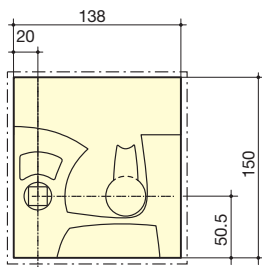

sifco_270_1_x_cat

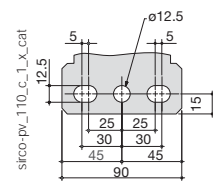

sifco-pv_110_c_1_x_cat

1000 A

1250 A

1600 - 2000 A

Rating (A) / Frame size	Overall dimensions B	Terminal shrouds AC	Switch body			Connection					
			F 4p.	J 4p.	M 4p.	T	U	V	X	Y	AA
1000 / B6	370	461	584	387	335	80	50	60.5	60	7	321
1250 / B6	370	461	584	387	335	80	60	65	60	7	330
1600 / B7	380	531	716	518.5	467	120	90	44	53	8	288
2000 / B7	380	531	716	518.5	467	120	90	44	53	8	288

Dimensions (mm) (continued)

250 to 630 A / B5 / 1500 VDC

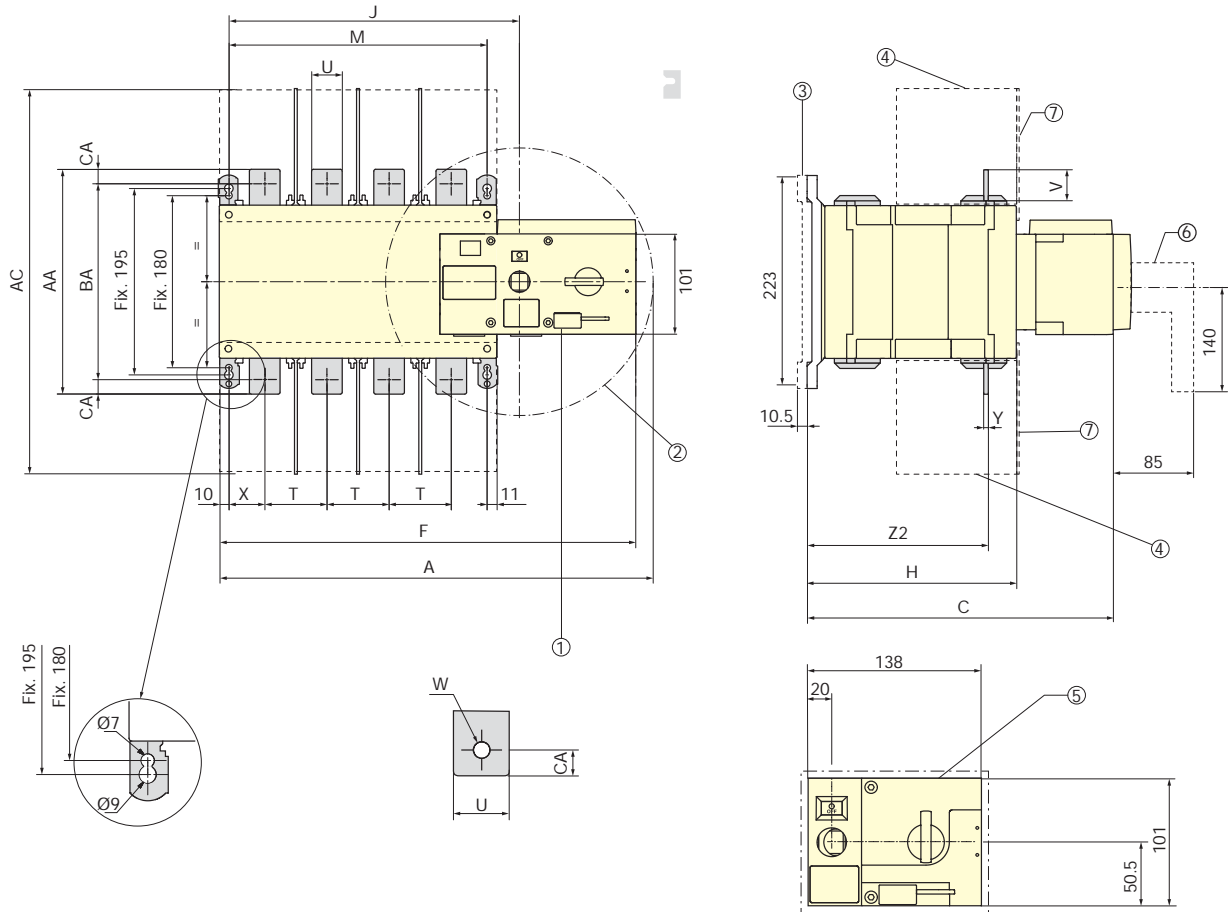

1. Padlocking Facility: Locking bracket for up to 3 padlocks of dia. 4 – 8mm
2. Emergency manual operation: Maximum operating radius with an operating angle of 90°
3. Mounting stand off with spacer accessory
4. Phase Barriers
5. Flush mounting cutout dimensions for front door
6. Emergency removable handle
7. Terminal screens



To consider the space required for manual operation and writing. (When using the emergency handle).

Rating (A) / Body size / Nb of pole	Overall dimensions		Terminal shrouds	Switch mounting				Connection										
	A	C	AC	F	H	J	J1	M	T	U	V	W	X	Y	Z2	AA	BA	CA
250/B5 - 3 pole	394	321	400	377	221	244	34	210	65	45	50	13	42.5	5	190	260	220	20
400/B5 - 3 pole	394	321	400	377	221	244	34	210	65	45	50	13	42.5	5	190	260	220	20
630/B5 - 4 pole	459	321	400	437	221	304	34	270	65	45	50	13	37.5	5	190	260	220	20

SIRCO MOT DC/SIRCO MOT DC ESS

Motorised load break switches for DC applications

from 250 to 3600A, up to 1500 VDC

Dimensions (mm) (continued)

1000 A / B6ds / 1500 VDC

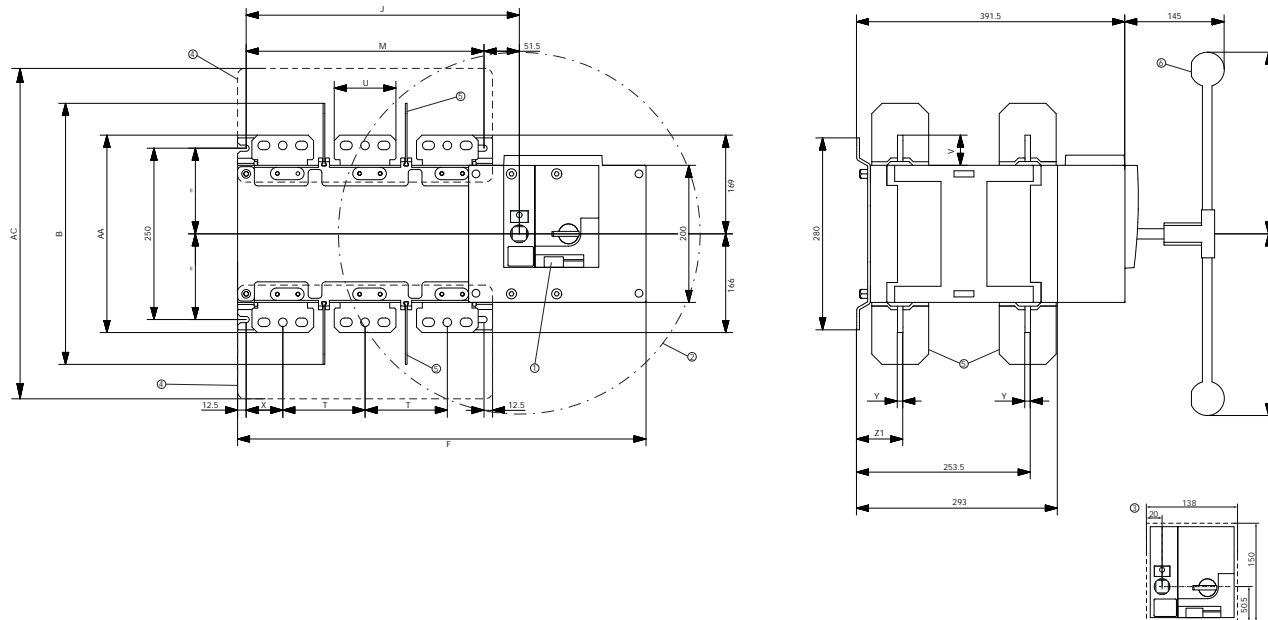

1000 A

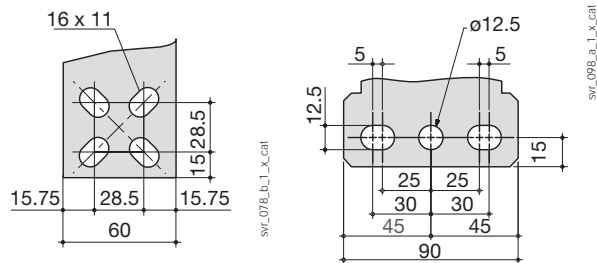

1. Padlocking Facility: Locking bracket for up to 3 padlocks of dia. 4 – 8mm
2. Emergency manual operation: Maximum operating radius with an operating angle of 90°
3. Flush mounting cutout dimensions for front door
4. Terminal screens
5. Phase Barriers
6. Emergency removable handle



To consider the space required for manual operation and writing. (When using the emergency handle).

Rating (A) / Body size	Overall dimensions B	Terminal screens AC	Body				Switch mounting		Connection						
			F 3p.	F 4p.	J 3p.	J 4p.	M 3p.	M 4p.	T	U	V	X	Y	Z1	AA
1000/B6	370	461	504	584	307	387	255	335	80	60	65	47.5	7	66.5	330

Dimensions (continued)

2000 to 3600 A / B7ds / 1500 VDC

Dimensions in inch / mm.

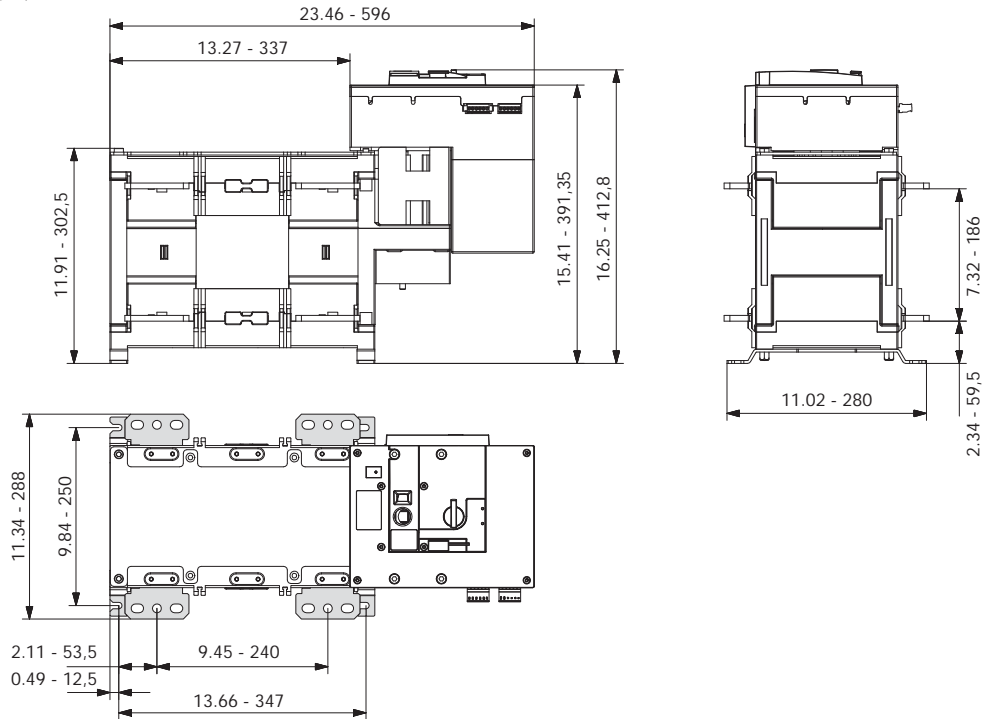

Bridging bar

250 - 400 A (1000 V)

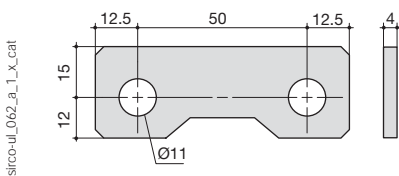

630 - 800 A (1000 V)

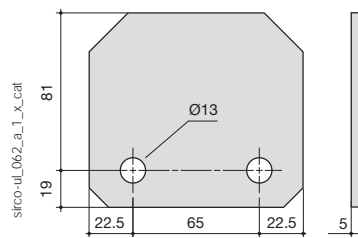

1000 - 1250 A (1000 V)

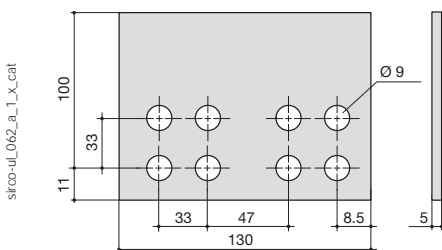

1600 A (1000 V)

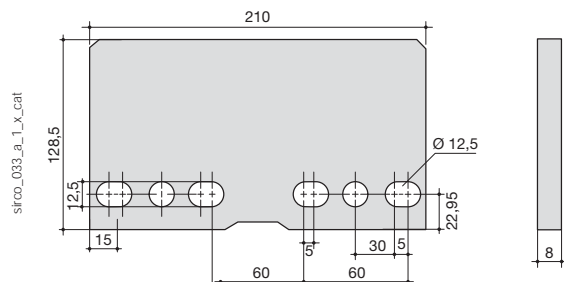

SIRCO MOT DC/SIRCO MOT DC ESS

Motorised load break switches for DC applications

from 250 to 3600A, up to 1500 VDC

Dimensions (continued)

2000 - (1000 V)

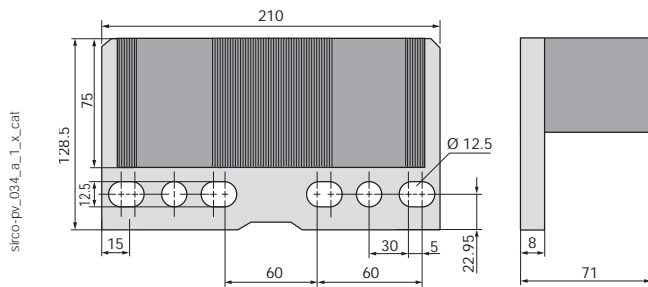

1800 - 3600 A (1500 V) - IEC

Dimensions in mm.

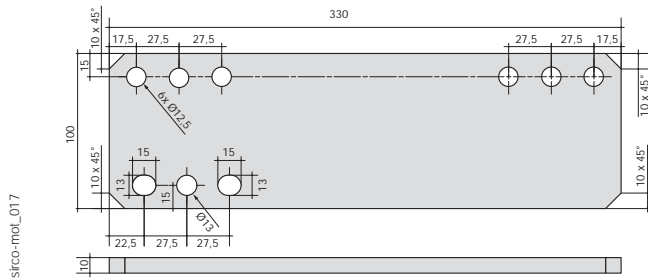

2000 A (1500 V) - UL

Dimensions in inch / mm.

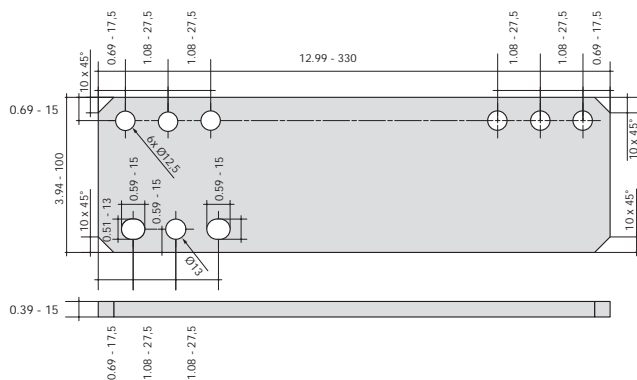

Pole series connections 1000 VDC ⁽¹⁾

4 poles - bottom / bottom

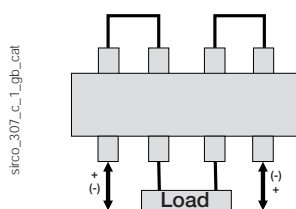

⁽¹⁾ Other connections: refer to mounting instructions

SIRCO MOT DC/SIRCO MOT DC ESS

Motorised load break switches for DC applications
from 250 to 3600 A, up to 1500 VDC

Pole series connections 1500 VDC

3 Pole connections - 250 - 400 A

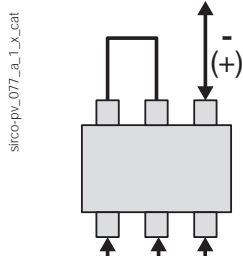

4 Pole connections - 630 A

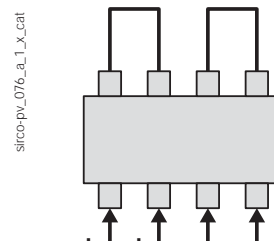

6 Pole connections - 1000 A

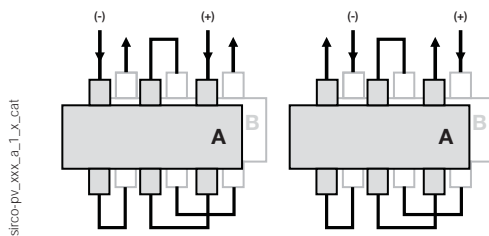

2 + 2 Pole (4 Pole) connections

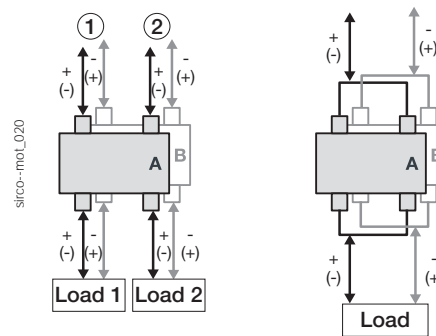

Two circuits up to 1600 A
One circuit up to 3600 A (IEC) & 2000 A (UL)

Load break switches

for specific applications

Despite already offering a wide range of load break switches, SOCOMEC also manufactures specific products to suit any requirement. Some of these products can be seen on these two pages. This list is not exhaustive.

Please do not hesitate to contact us.

SIRCO range with overrated neutral



SIRCO 3 x 250 A with 400 A rated neutral

The use of power electronics is becoming more and more frequent. Chopper, rectifiers and current inverters distort the signal by reinjecting the 3rd order harmonics which are combined in the neutral. Range available from 125 to 1800 A.

Compliance with standards

- > IEC 60947-3
- > BS EN 60947-3
- > EN 60947-3
- > NBN EN 60947-3
- > VDE 0660-107 (1992)



SIRCO high short-circuit withstand



- 80 kA rms 1 s.
- 110 kA rms 0.1 s.
- 240 kA peak.

SIRCO early break AC



SIRCO 3 x 1250 A with early prebreak AC

- Complete range from 125 to 3200 A.
- Double positive break indication given through a position indication window, located directly on the product, and by the operating handle.
- Features an early break auxiliary contact as standard.
- Severe load duty categories (AC-22 and AC-23).
- High resistance to damp heat (supplied "tropicalised").

SIRCO for earthing

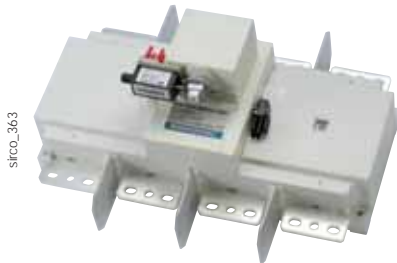

- From 800 to 1800 A.
- 50 kA rms 1 s.
- Special S4 type handle.
- Undervoltage coil interlocking.

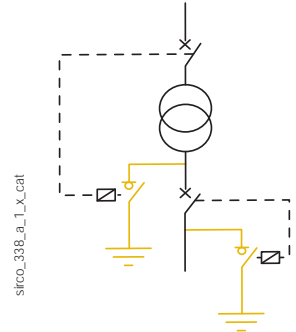

Remotely operated load break switches

SIRCO MOT AT



Function

SIRCO MOT AT are remotely operated 3/4 pole load break switches. They make and break under load conditions and provide safety isolation for any low voltage electrical circuit. This is ensured via volt-free contacts using either a pulse or contactor logic.

Advantages

- **Extended power range**
These products offer great flexibility thanks to a wide power supply range of 208 to 277 VAC $\pm 20\%$.
- **Integrated auxiliary contacts**
As part of the product monitoring function, the SIRCO MOT AT enables the transmission of information relating to their position. This is possible thanks to the standard integration of an auxiliary contact for each position.

General characteristics

- 2 stable positions (I, 0).
- One auxiliary contact per position as standard.
- Positive break indication
- AUT/MAN selector.
- Manual emergency operation.
- Padlocking in position 0 (position I optional).
- Ratings: from 125 to 3200 A.

References

Rating (A)		125	160	250	400	630	800
No. of poles	Power supply voltage	Reference	Reference	Reference	Reference	Reference	Reference
3 P	230 VAC	9915 3012	9915 3016	9915 3025	9915 3040	9915 3063	9915 3080
4 P	230 VAC	9915 4012	9915 4016	9915 4025	9915 4040	9915 4063	9915 4080

Rating (A)		1000	1250	1600	2000	2500	3200
No. of poles	Power supply voltage	Reference	Reference	Reference	Reference	Reference	Reference
3 P	230 VAC	9915 3100	9915 3120	9915 3160	9915 3200	9915 3250	9915 3320
4 P	230 VAC	9915 4100	9915 4120	9915 4160	9915 4200	9915 4250	9915 4320

UL and CSA load break switches

from 16 to 1200 A



Something to think about

- > SOCOMEC also offers a full range of load break switches, with direct or front external control that fully comply with UL & CSA standards.
- > A specific UL/CSA product catalogue is available on request, don't hesitate to contact us for your copy.
- > Important: all electrical equipment designed for the North American market must conform to UL/CSA standards.

Compliance with standards

- > UL 508
(file UL E 173959)
- > UL 98
(file UL E 201138)
- > CSA 22.2 n°4
(file CSA 189705)



Function

Standard UL 508: load break switches for control of electric motors

They ensure on-load making and breaking and provide safety isolation for motor control up to 600 V.

Standard UL 98 and UL 489: load break switches

They ensure on-load making and breaking and provide safety isolation for all electrical circuits up to 600 V.

General characteristics

SIRCO M

- Positive break indication
- Backplate or DIN-rail mounting.
- Padlocking in position 0 with max. 3 padlocks for external control.
- Door locked when the switch is on for devices with external front operation.

SIRCO

- Positive break indication.
- Padlocking in position 0 with max. 3 padlocks for external control.
- Door locked when the switch is on for devices with external front operation.

INOSYS LBS

- Visible breaking (contact position indication).
- Shunt or undervoltage tripping function from 24 to 220 VDC and from 24 to 230 VAC.
- Opening and closing independent of speed of movement.
- No de-rating up to 60°C and an operating temperature range of -25 to +70°C.

Standard UL 508: motor control

SIRCO M

Rating (A)	16	20	25	30	40	60	80
N° of poles							
3 P	•	•	•	•	•	•	•
4 P	•	•	•	•	•	•	•
Operation type							
Frontal direct/external	•	•	•	•	•	•	•
Type of mounting							
Front/back	•	•	•	•	•		



sircm_132_a

Standard UL 489: load break switches

SIRCO V

Rating (A)	Operation type	30
3 P	Frontal direct/external	•
3 P + switched neutral	Lateral direct/external	•



sirco_092_a_1_cat

Standard UL 98: load break switches

SIRCO M and SIRCO

Type	SIRCO M			SIRCO					
Rating (A)	30	60	100	200	400	600	800	1000	1200
N° of poles									
3 P	•	•	•	•	•	•	•	•	•
4 P	•	•	•	•	•	•	•	•	•
Operation type									
External front	•	•	•	•	•	•	•	•	•



sirco_ul_022_b_1_cat



Fuse protection

Fuse solutions: undeniable advantages over circuit breakers..... *p. 130*

Why choose Socomec?..... *p. 131*

Selection guide for fuse protection..... *p. 132*

Front/side-control fuse combination switches

Motor protection



FUSERBLOC
< 50 A
p. 134

Protection for main switchboards



FUSERBLOC
50 to 400 A
p. 134

Protection for distribution boards



FUSERBLOC
630 to 1250 A
p. 134

Direct-control fuse combination switches

Motor protection



FUSERBLOC
< 50 A
Consult us

Protection for main switchboards



FUSERBLOC
50 to 400 A
Consult us

Front/side-control uR fuse combination switches

Semi-conductor protection



FUSERBLOC
for uR fuses
50 à 1250 A
Consult us

Fuse combination switches with tripping function and visible breaking



FUSOMAT
250 to 1250 A
Consult us



SIDERMAT
combination
1600 to 1800 A
Consult us

Fused disconnectors



RM - RMS
32 to 125 A
p. 168



new
RM CC
Class CC
30 A
Consult us

Fuse base



Fuse base
160 to 2500 A
p. 174



IP2X fuse base
160 to 2500 A
Consult us

Industrial fuses

Distribution protection



gG fuses
0.5 to 1250 A
p. 180

Motor protection



aM fuses
0.16 to 1250 A
p. 180

Semi-conductor protection



uR fuses
5 to 2000 A
Consult us

Photovoltaic industrial fuses



RM PV
32 to 50 A
p. 180



RM PV
32 A
1500 VDC
p. 190



PV
fuse bases
32 to 600 A
p. 192



gPV fuses
1 to 600 A
p. 194

Special products

Fuse combination switches for special applications



Fuse protection solutions > 2500 A

Consult us

UL / CSA range

Fused isolator switches compliant with standards UL489, UL98 and CSA C22.2

Approuvés pour l'utilisation dans les applications les plus sévères, telles que l'interrupteur de tête (Service Entrance) et pour la protection et déconnexion du moteur :

- Standard positions 0 and 1
- Standard positions 0, 1 and Test.

For UL class CC, J, L... fuses : please contact us.



30 to 800 A
Consult us

Compliant with standard IEC / EN 61439

All the steps for producing an assembly that complies with this standard can be found in our guide, "Implementing standard IEC / EN 61439".
https://www.socomec.com/catalogues-brochures_en.html

Fuse solutions: undeniable advantages over circuit breakers

SOCOMEC has always promoted the benefits of fuses for both personal and equipment safety. In fact, fuse protection offers serious benefits compared to the circuit breaker in a large number of applications.

Fuse switches guarantee reliable breaking and protection, from the distribution of power to protection of the motor. Key benefits at a glance:

- **Highly limited short circuits**

The thermal and mechanical effects generated during a short circuit can be considerable. The speed of a fuse's break capacity ensures a much better limitation of the fault current than circuit breaker solutions (see Fig. 1).

- **High breaking capacity**

Our fuses have a 100 kA breaking capacity (or more); so you don't have to worry about the short-circuit current when choosing the product for you.

- **Easy selection**

Discrimination between upstream and downstream fuses of the same type is guaranteed as long as the upstream fuse rating is 1.6 times or more higher than the downstream fuse. This feature guarantees a seamless supply of energy (see the example in Fig. 2).

- **Confined breaking**

During a short-circuit, the generated energy is absorbed by the silica and remains contained in the body of the fuse, avoiding the spread of the arc or even the projection of incandescent materials.

- **Double breaking**

Our switch disconnectors break the circuit upstream and downstream of the fuse, allowing it to be replaced safely.

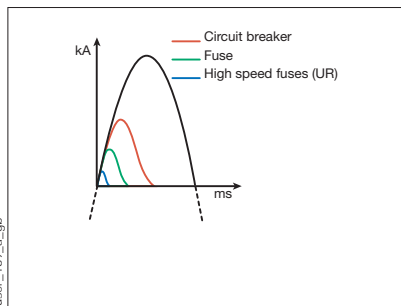

Fig. 1: Limiting the current

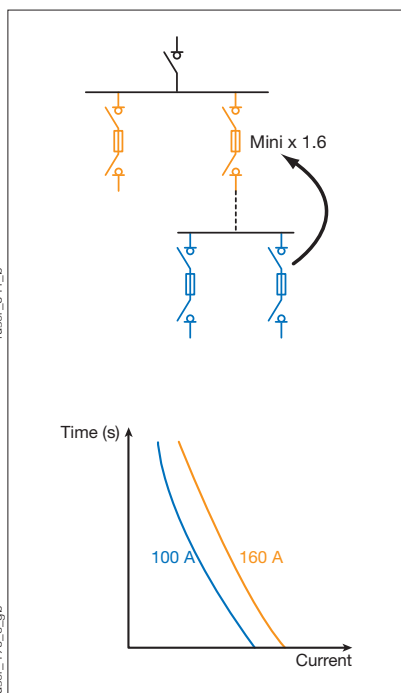

Fig. 2: Example of total selectivity



Good to know

- Controlled with the high/low voltage transformer sensor, triggering fuse switch disconnectors are the best way to ensure cut-off and general protection functions.
- Protecting your system with ultra-rapid (uR) fuses is the only way to effectively protect the semiconductors used in electronic equipment (variable speed drives, etc.) against short circuits.

Photovoltaic applications

SOCOMEC offers solutions for fuse load break switches and fuse disconnect switches.

Contact us

Technical specifications

All the information you need about how to control your electrical system is just one click away!



www.socomec.com/application-guide-scp_en

Why choose Socomec?

With over 90 years of experience, SOCOMEC offers a range of switches and components for building a complete fuse protection solution. Working with us will also bring you plenty of other benefits:



An active commercial network

Our service teams have built their reputation on reassuring guidance, flexible skills and reactivity.



Quality products

SOCOMEC is recognised by its customers for the reliability of its fuse solutions.



A wide range

Whatever your business (industry, data centres, photovoltaics, etc.), we can meet all your electrical protection needs with this product range.



Customised solutions

Do our standard products not meet your needs? As a specialised manufacturer, we can adapt our products to your specific needs. Contact us today to look into every option. Contact your SOCOMEC representative.

What you need to know!

We also offer a wide range of devices that safely protect both people and electronic devices (differential protection, surge protection). See the section, "Electronic protection".



ressys_081_a

sgsys_076_a_1_cat

Selection guide

Fuse protection

Application?



Type of operation?

Industry					
FUSERBLOC Front/side control 25 to 1250 A <i>p. 134</i>	FUSERBLOC Direct control 25 to 400 A <i>Consult us</i>	FUSOMAT SIDERMAT combination 250 to 1800 A <i>Consult us</i>	RM - RMS 32 to 125 A <i>p. 168</i>	Fuse bases 160 to 2500 A <i>p. 174</i>	gG and AM NFC/DIN 0.16 to 1250 A <i>p. 180</i>

Applications

Transformer output			•			•
Section connectors				•	•	•
Cabinet entrance	•	•	•			•
Wiring						•
Motor circuits	•	•	•			•
Semi-conductor protection				•	•	
Photovoltaic installations						

Device operation

Manual	•	•	•			
Via tripping			•			

Location of manual handle

Front		•	•			
Side		•	up to 1250 A			
Via a panel		up to 32 A				

Location of external handle

Front	•		•			
Right side	•		up to 1250 A			
Left side	Contact us					
Central	Contact us					

Breaking

Fully visible	•	•	•			
Visible			•			

Fuses

NFC/DIN	• / •	• / •	- / •	• / -	- / •	•
BS	see the UK catalogue	see the UK catalogue				•
UL	see UL catalogue	see UL catalogue				•
Other						

▶ Location of operating handle? ▶

▶ Positive or visible break indication? ▶

▶ Type of fuse? ▶

Power electronics (inverters, UPS)		Photovoltaics			
					
FUSERBLOC for uR fuses	uR fuses	RM PV	RM PV	PV fuse bases	gPV fuses
50 to 1250 A <i>Consult us</i>	5 to 2000 A <i>Consult us</i>	32 to 50 A <i>p. 190</i>	32 A - 1500 VDC <i>p. 190</i>	2 to 600 A <i>p. 192</i>	1 to 600 A <i>p. 194</i>
•	•	•	•	•	•
•					
•					
•					
•					
•					
•					
•					
•					
• / •	•				
	•	gPV	gPV	gPV	gPV

FUSERBLOC

Front/side-control fuse combination switches
for industrial fuses up to 1250 A



Function

The **front/right-side FUSERBLOC** is a manually operated multi-pole fuse load break switch. They make and break on load and provide safety isolation and protection against overcurrent for any low voltage electrical circuit.

This range includes both direct and external-control models, with 2, 3 and 4 poles and from 25 to 1250 A.

Advantages

Improved safety

- Complete isolation of the fuse with double breaking per pole (top and bottom of fuse).
- Positive break indication

High breaking capacity

Protection against overloads and short-circuits thanks to high breaking capacity fuses (100 kA rms).

Multi-use

A single device can be operated with a handle, either mounted directly on the unit itself or externally, on the door or on the side of an electrical enclosure or cabinet.

Specific functionalities for simplified use

- TEST position for front/side-control devices up to 400 A allows control circuits to be tested without switching power, thanks to the use of U-type auxiliary contacts. In the TEST position, the cabinet door can be opened.
- Mechanical or electronic fuse blown detection system (see DDMM or FMD).

The solution for

- > Motor feeders
- > Protection of industrial cabinets



Strong points

- > Improved safety
- > High breaking capacity
- > Multi-use
- > Specific functionalities for simplified use

Extended range

- > Centred or left side operation, rear connections, plug-in connections.
- Contact us

Compliance with standards

- > IEC 60947-3
- > EN 60947-3
- > BS EN 60947-3
- > NBN EN 60947-3
- > IEC 60269-1
- > DIN EN 60269-1
- > NF EN 60269-1
- > IEC 60269-2
- > GB/T14048.3
- > VDE 0636-1
- > VDE 0660-107
- > UL standards: see FUSERBLOC UL



Approvals and certifications⁽¹⁾



LOVAG



⁽¹⁾ Product references on request.

Customised solutions

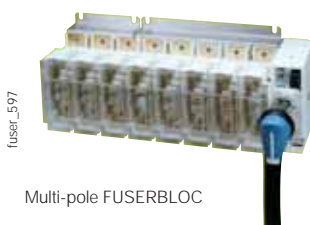

What you need to know

- In addition to the FUSERBLOC rating, product selection also depends on the fuse characteristics and functional specifications, which need to be in accordance with the application. SOCOMEC FUSERBLOC devices are equipped with **NFC/DIN fuses** (for BS fuses, please contact us)



- FUSERBLOC fuse combination switch
- Handle for external front and side control
- U-type auxiliary contacts (pre-break and position signalling)
- Auxiliary power contacts (position signalling)
- Mechanical fuse melting detection device (DDMM)
- Upstream and downstream terminal shrouds
- Integrated solid neutral link
- Electronic fuse melting detection (FMD) makes it possible to have an automatic supervision or management system. Compatible with BS88, DIN and UL fuses
 - Visual LED signalling
 - Bi-stable relay for automation devices: alarm, tripping, etc.
 - TEST button: test the device is working properly at any time
 - Mounting plate or DIN rail, on door or directly on the FUSERBLOC
- Direct control box.

- Whether it is 3-pole + switched neutral or 3-pole + solid neutral, the 25 to 32 A FUSERBLOC with **direct and external control** is the best compact solution.

- For ratings 25 to 400 A, the **flat mounting kit** provides a compact solution ideally suited to plug-in units.
- Maintaining outputs from the DC common bus.



FUSERBLOC

Front/side-control fuse combination switches

for industrial fuses up to 1250 A

References

NFC and DIN – front/right-side operation – 25 to 125 A

Rating (A) / Fuse size / Casing size	No. of poles	Switch body	Direct front handle I-0-TEST	External front handle I - 0	TEST external front handle I - 0 - TEST	External right-side handle I - 0	Shaft for handle	Auxiliary contact	Terminal shrouds	Electronic fuse blown indication ⁽⁵⁾						
CD 25 A / 10 x 38 / 0	3 P	3631 3002 ⁽¹⁾	3629 4012	Type S1 Black IP55 1411 2111 ⁽²⁾ Black IP65 1413 2111 Red/Yellow IP65 1414 2111	Type S1 Black IP65 1413 2115 Red IP65 1414 2115	Type S1 Black IP55 1415 2111 ⁽²⁾ Black IP65 1417 2111 Red/Yellow IP65 1418 2111	200 mm 1401 0520 320 mm 1401 0532 ⁽²⁾									
	3 P + switched neutral	3631 4002 ⁽¹⁾														
	3 P+ solid neutral	3631 5002 ⁽¹⁾														
CD 32 A / 10 x 38 / 0	3 P	3631 3003														
	3 P + switched neutral	3631 4003														
	3 P+ solid neutral	3631 5003														
CD 32 A / 14 x 51 / 0	3 P	3631 3004 ⁽¹⁾														
	3 P + switched neutral	3631 4004 ⁽¹⁾														
	3 P+ solid neutral	3631 5004 ⁽¹⁾														
50 A / 14 x 51 / 11	2 P	3831 2005	3999 5020	S2 type Black IP55 1421 2111 ⁽²⁾ Black IP65 1423 2111 Red IP65 1424 2111	S2 type Black IP65 1423 2115 Red IP65 1424 2115	S2 type Black IP55 1425 2111 ⁽²⁾ Black IP65 1427 2111 Red IP65 1428 2111	200 mm 1400 1020 320 mm 1400 1032 ⁽²⁾ 500 mm 1400 1050	Type U 1 contact NC 3999 0701 ⁽³⁾ 1 contact NO 3999 0702 ⁽³⁾	3 LEDs 155...260 VAC 3899 3120 3 LEDs 380 - 690 VAC 3899 3380							
	3 P	3831 3005 ⁽¹⁾														
	4 P	3831 6005 ⁽¹⁾														
63 A / 00C / 12	2 P	3831 2006														
	3 P	3831 3006 ⁽¹⁾														
	4 P	3831 6006 ⁽¹⁾														
100 A / 22 x 58 / 13	2 P	3831 2010														
	3 P	3831 3010 ⁽¹⁾														
	4 P	3831 6010 ⁽¹⁾														
125 A / 22 x 58 / 13	2 P	3831 2011														
	3 P	3831 3011														
	4 P	3831 6011														
125 A / 00 / 13	2 P	3831 2012								3999 5020	S2 type Black IP55 1421 2111 ⁽²⁾ Black IP65 1423 2111 Red IP65 1424 2111	S2 type Black IP65 1423 2115 Red IP65 1424 2115	S2 type Black IP55 1425 2111 ⁽²⁾ Black IP65 1427 2111 Red IP65 1428 2111	200 mm 1400 1020 320 mm 1400 1032 ⁽²⁾ 500 mm 1400 1050	Type U 1 contact NC 3999 0701 ⁽³⁾ 1 contact NO 3999 0702 ⁽³⁾	3 LEDs 155...260 VAC 3899 3120 3 LEDs 380...690 VAC 3899 3380
	3 P	3831 3012														
	4 P	3831 6012														
125 A / 00 / 13	2 P	3831 2012														
	3 P	3831 3012														
	4 P	3831 6012														

(1) Available enclosed (see "Enclosed fuse switches").

(2) Standard.

(3) Maximum 4 contacts.

(4) Top or bottom. Provide 2 terminal shrouds for complete upstream and downstream protection.

(5) Mechanical fuse blown auxiliary contact (DDMM), see "Accessories".

NFC and DIN – front/right-side operation – 160 to 1250 A

Rating (A) / Fuse / Casing size	No. of poles	Switch body	Direct front handle I-0-TEST	External front handle I - 0	External front TEST handle I - 0 - Test	External right side handle I - 0	Shaft for handle	Auxiliary contact	Terminal shrouds	Electronic fuse blown indication ⁽⁶⁾					
160 A / 00 / 13	2 P	3831 2015	3999 5020	S2 type Black IP55 1421 2111 ⁽²⁾ Black IP65 1423 2111 Red IP65 1424 2111	S2 type Black IP65 1423 2115 Red IP65 1424 2115	S2 type Black IP55 1425 2111 ⁽²⁾ Black IP65 1427 2111 Red IP65 1428 2111	200 mm 1400 1020 320 mm 1400 1032 500 mm 1400 1050	Type U 1 contact NC 3999 0701 ⁽⁴⁾ 1 contact NO 3999 0702 ⁽⁴⁾	2 P 3998 2016 ⁽⁵⁾	3 LEDs 155...260 VAC 3899 3120 3 LEDs 380...690 VAC 3899 3380					
	3 P	3831 3015							3 P 3998 3016 ⁽⁵⁾						
	4 P	3831 6015							4 P 3998 4016 ⁽⁵⁾						
160 A / 0 / 14	2 P	3831 2016							3999 5021		Type S3 Black IP65 1433 3111 ⁽²⁾ Red IP65 1434 3111	Type S3 Black IP65 1437 7911	200 mm 1400 1220 320 mm 1400 1232 500 mm 1400 1250	Type U 1 contact NC 3999 0701 ⁽⁴⁾ 1 contact NO 3999 0702 ⁽⁴⁾	2 P 3898 2025 ⁽⁵⁾
	3 P	3831 3016 ⁽¹⁾													3 P 3998 3025 ⁽⁵⁾
	4 P	3831 6016 ⁽¹⁾													4 P 3998 4025 ⁽⁵⁾
250 A / 1 / 15	2 P	3831 2024	3899 6011	Type S4 Black IP65 1443 3111 ⁽²⁾ Red IP65 1444 3111	Type U 1 contact NC 3999 0701 ⁽⁴⁾ 1 contact NO 3999 0702 ⁽⁴⁾	2 P 3898 2040 3 P 3898 3040 4 P 3898 4040	Type U 1 contact NC 3999 0701 ⁽⁴⁾ 1 contact NO 3999 0702 ⁽⁴⁾	2 P 3898 2040							
	3 P	3831 3024 ⁽¹⁾						3 P 3898 3025 ⁽⁵⁾							
	4 P	3831 6024 ⁽¹⁾						4 P 3898 4025 ⁽⁵⁾							
400 A / 2 / 16	2 P	3831 2038	1141 3011	Type S4 Black IP65 1443 3111 ⁽²⁾ Red IP65 1444 3111	Type U 1 contact NC 3999 0701 ⁽⁴⁾ 1 contact NO 3999 0702 ⁽⁴⁾	2 P 3898 2120 ⁽⁵⁾ 3 P 3898 3120 ⁽⁵⁾ 4 P 3898 4120 ⁽⁵⁾	Type U 1 contact NC 3999 0701 ⁽⁴⁾ 1 contact NO 3999 0702 ⁽⁴⁾	2 P 3898 2038							
	3 P	3831 3038 ⁽¹⁾						3 P 3898 3040							
	4 P	3831 6038 ⁽¹⁾						4 P 3898 4040							
630 A / 3 / 17	2 P	3811 2063	1141 3011	Type S4 Black IP65 1443 3111 ⁽²⁾ Red IP65 1444 3111	Type U 1 contact NC 3999 0701 ⁽⁴⁾ 1 contact NO 3999 0702 ⁽⁴⁾	2 P 3898 2120 ⁽⁵⁾ 3 P 3898 3120 ⁽⁵⁾ 4 P 3898 4120 ⁽⁵⁾	Type U 1 contact NC 3999 0701 ⁽⁴⁾ 1 contact NO 3999 0702 ⁽⁴⁾	2 P 3898 2063							
	3 P	3811 3063 ⁽¹⁾						3 P 3898 3080 ⁽⁵⁾							
	4 P	3811 6063 ⁽¹⁾						4 P 3898 4080 ⁽⁵⁾							
800 A / 3 / 17	2 P	3811 2080	1141 3011	Type S4 Black IP65 1443 3111 ⁽²⁾ Red IP65 1444 3111	Type U 1 contact NC 3999 0701 ⁽⁴⁾ 1 contact NO 3999 0702 ⁽⁴⁾	2 P 3898 2120 ⁽⁵⁾ 3 P 3898 3120 ⁽⁵⁾ 4 P 3898 4120 ⁽⁵⁾	Type U 1 contact NC 3999 0701 ⁽⁴⁾ 1 contact NO 3999 0702 ⁽⁴⁾	2 P 3898 2080							
	3 P	3811 3080						3 P 3898 3080 ⁽⁵⁾							
	4 P	3811 6080						4 P 3898 4080 ⁽⁵⁾							
800 A / 4 / 18	2 P	3811 2081	1141 3011	Type S4 Black IP65 1443 3111 ⁽²⁾ Red IP65 1444 3111	Type U 1 contact NC 3999 0701 ⁽⁴⁾ 1 contact NO 3999 0702 ⁽⁴⁾	2 P 3898 2120 ⁽⁵⁾ 3 P 3898 3120 ⁽⁵⁾ 4 P 3898 4120 ⁽⁵⁾	Type U 1 contact NC 3999 0701 ⁽⁴⁾ 1 contact NO 3999 0702 ⁽⁴⁾	2 P 3898 2081							
	3 P	3811 3081						3 P 3898 3120 ⁽⁵⁾							
	4 P	3811 6081						4 P 3898 4120 ⁽⁵⁾							
1250 A / 4 / 18	2 P	3811 2120	1141 3011	Type S4 Black IP65 1443 3111 ⁽²⁾ Red IP65 1444 3111	Type U 1 contact NC 3999 0701 ⁽⁴⁾ 1 contact NO 3999 0702 ⁽⁴⁾	2 P 3898 2120 ⁽⁵⁾ 3 P 3898 3120 ⁽⁵⁾ 4 P 3898 4120 ⁽⁵⁾	Type U 1 contact NC 3999 0701 ⁽⁴⁾ 1 contact NO 3999 0702 ⁽⁴⁾	2 P 3898 2120							
	3 P	3811 3120						3 P 3898 3120 ⁽⁵⁾							
	4 P	3811 6120						4 P 3898 4120 ⁽⁵⁾							

(1) Available enclosed (see "Enclosed fuse switches").

(2) Standard.

(3) Maximum 4 contacts.

(4) Maximum 8 contacts.

(5) Top or bottom. Provide 2 terminal shrouds for complete upstream and downstream protection.

(6) Mechanical fuse blown auxiliary contact (DDMM), see "Accessories".

FUSERBLOC

Front/side-control fuse combination switches
for industrial fuses up to 1250 A

Accessories

Frame front handle can be locked in position 0 for direct control

Rating (A)	Frame size	Command	Handle colour	Reference
50 - 160	11-12-13-14	I-0-TEST	Black	3999 5020
250 - 400	15-16	I-0-TEST	Black	3999 5021



Direct front-operation handle

Front operation				
Rating (A)	Frame size	Figure N°	Handle colour	Reference
20 - 32	0	1	Black	3629 4012
20 - 32	0	1	Red	3629 4013
630 - 800	17	2	Black	3899 6011
800 - 1250	18	3	Black	1141 3011



Fig. 1

Fig. 2

Fig. 3

Handle locks in position 0 for external control

Padlockable handle in position 0							
Rating (A)	Frame size	Handle type	Handle colour	Command	External IP ⁽¹⁾	Defeatable handle	Reference
CD 25 ... 63	0/11/12	S1	Black	I - 0	IP55	Yes	1411 2111
CD 25 ... 63	0/11/12	S1	Black	I - 0	IP65	Yes	1413 2111
CD 25 ... 63	0/11/12	S1	Red/Yellow	I - 0	IP65	Yes	1414 2111
CD 25 ... 63	0/11/12	S1	Black	I - 0 - Test	IP65	Yes	1413 2115
CD 25 ... 63	0/11/12	S1	Red/Yellow	I - 0 - Test	IP65	Yes	1414 2115
100 - 400	13 ... 16	S2	Black	I - 0	IP55	Yes	1421 2111
100 - 400	13 ... 16	S2	Black	I - 0	IP65	Yes	1423 2111
100 - 400	13 ... 16	S2	Red/Yellow	I - 0	IP65	Yes	1424 2111
100 - 400	13 ... 16	S2	Black	I - 0 - Test	IP55	Yes	1423 2115
100 - 400	13 ... 16	S2	Red/Yellow	I - 0 - Test	IP65	Yes	1424 2115
630 ... 800	17	S3	Black	I - 0	IP65	Yes	1433 3111
630 ... 800	17	S3	Red/Yellow	I - 0	IP65	Yes	1434 3111
800 ... 1250	18	S4	Black	I - 0	IP65	Yes	1443 3111
800 ... 1250	18	S4	Red/Yellow	I - 0	IP65	Yes	1444 3111

(1) IP: protection index according to IEC 60529.



Padlockable handle in position 1-0 for external control

Padlockable handle in position 0 and I					
Rating (A)	Frame size	Handle type	Handle colour	External IP ⁽¹⁾	Reference
CD 25 ... 63	0/11/12	S1	Black	IP65	1413 2311
100 - 400	13 ... 16	S2	Black	IP65	1423 2311

(1) IP: protection index according to IEC 60529.



Padlockable metal handle in position 1-0 for external front control

Rating (A)	Frame size	Handle type	Handle colour	External IP ⁽¹⁾	Defeatable handle	Reference
CD 25 ... 63	0/11/12	S1	Black	IP65	Yes	141D 2911
CD 25 ... 63	0/11/12	S1	Red/Yellow	IP65	Yes	141E 2911
100 - 400	13 ... 16	S2	Black	IP65	Yes	142D 2911
100 - 400	13 ... 16	S2	Red/Yellow	IP65	Yes	142E 2911
600 ... 800	17	S3	Black	IP65	Yes	143D 3911
600 ... 800	17	S3	Red/Yellow	IP65	Yes	143E 3911
800 ... 1250	18	S4	Black	IP65	Yes	144D 3911
800 ... 1250	18	S4	Red/Yellow	IP65	Yes	144E 3911

(1) IP: protection index according to IEC 60529.



Handle locks in position 1-0 for external side control

Rating (A)	Frame size	Handle type	Handle colour	External IP ⁽¹⁾	Reference
CD 25 ... 63	0/11/12	S1	Black	IP55	1415 2111
CD 25 ... 63	0/11/12	S1	Black	IP65	1417 2111
CD 25 ... 63	0/11/12	S1	Red/Yellow	IP65	1418 2111
100 - 400	13 ... 16	S2	Black	IP55	1425 2111
100 - 400	13 ... 16	S2	Black	IP65	1427 2111
100 - 400	13 ... 16	S2	Red/Yellow	IP65	1428 2111
630 ... 1250	17/18	S3	Black	IP65	1437 3111
630 ... 1250	17/18	S3	Red/Yellow	IP65	1438 3111

(1) IP: protection index according to IEC 60529.



Type S handle adapter

Use

Handle extension.

Dimensions

Add 12 mm to the handle depth.

Handle colour	Available for order in multiples of	External IP ⁽¹⁾	Reference
Black	1	IP65	1493 0000

(1) IP: protection index according to IEC 60529.



Alternative colour Type S handle cover

Use

For single lever handle types S1, S2, S3 and double lever handle type S4.
Other colours available - please contact us.

Handle colour	Available for order in multiples of	Handle type	Reference
Light grey	50	S1, S2, S3	1401 0001
Dark grey	50	S1, S2, S3	1401 0011
Light grey	50	S4	1401 0031
Dark grey	50	S4	1401 0041



FUSERBLOC

Front/side-control fuse combination switches
for industrial fuses up to 1250 A

Accessories (continued)

Shaft extensions for external front

Use

Standard lengths:

- 200 mm
- 320 mm
- 400 mm
- 500 mm.

Other lengths available - please contact us.

Rating (A)	Frame size	Shaft length (mm)	Reference
CD 25 ...CD 32	0	200	1401 0520
CD 25 ...CD 32	0	320	1401 0532
CD 25 ...CD 32	0	400	1401 0540 ⁽¹⁾
50 - 400	11 ... 16	200	1400 1020
50 - 400	11 ... 16	320	1400 1032
50 - 400	11 ... 16	500	1400 1050 ⁽²⁾
630 ...800	17	200	1400 1220
630 ...1250	17/18	320	1400 1232
630 ... 1250	17/18	500	1400 1250 ⁽¹⁾

(1) Use the accessory "guide cone for external operation".

(2) Use the accessory "shaft extension support for external front operation".

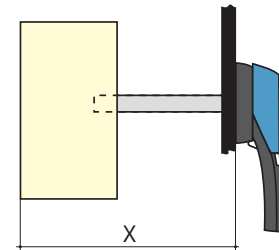
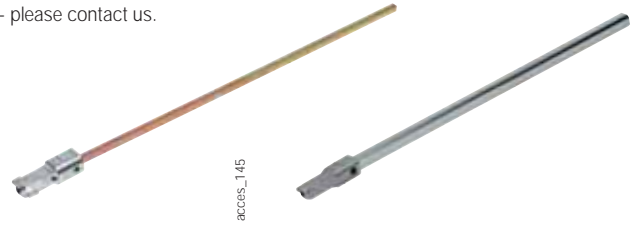

Dimension X (mm) for FUSERBLOC NFC and DIN

Rating (A)	CD 25 ...CD 32	50	63	100 ... 160	160	250 ...400	630 ... 800	800 ... 1250
Fuse size	10x38/14x51	14x51	00C	22x58/00	0	1/2	3	4
Frame size	0	11	12	13	14	15/16	17	18
Shaft extension length (mm)								
200	102 ... 245	100 ... 230	125 ... 230	135 ... 230	145 ... 230	160 ... 230	270 ... 304	
320	102 ... 365	100 ... 350	125 ... 350	135 ... 350	145 ... 350	160 ... 350	270 ... 424	304 - 424
400	102 ... 445	100 - 430	125 - 430	135 - 430	145 - 430	160 - 430	270 - 504	304 - 504
500		100 ... 530	125 ... 530	135 ... 530	145 ... 530	160 ... 530	270 ... 604	304 - 604

Shaft for external side operation

Use

Standard length, 200 mm.

Rating (A)	Frame size	Handle type	Dimension Y (mm)	Shaft length (mm)	Reference
CD 25 ...CD 32	0	S	36 ... 159	200	1401 0520
50 - 400	11 ... 16	S	36 ... 172	200	1400 1020
630 ... 1250	17/18	S	15 ... 150	200	1400 1220

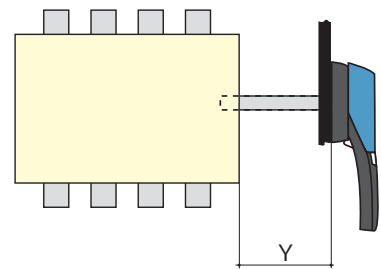

Shaft guide for external operation

Use

For use with S Type handles, to guide the shaft extension into the external handle.

This accessory enables the handle to engage the extension shaft with a misalignment of up to 15 mm.

Required for a shaft length over 320 mm.

Designation	Reference
Shaft guide	1429 0000



Key handle interlocking system

Use

Locking in position 0 of the direct, front or right side operation:

- using a padlock (not supplied) in direct right side operation: available as standard on the handle,

- using a padlock (not supplied): right-side or front operation switch from 50 to 1250 A, integrated as standard

- using a lock (not supplied) in external operation.

Locking using RONIS EL 11 AP lock (not supplied)

Rating (A)	Frame size	Command	Figure N°	Reference
CD 25 ... 1250	0 ... 18	external front	1	1499 7701

Locking using Type K CASTELL lock (not supplied)

Rating (A)	Frame size	Command	Figure N°	Reference
CD 25 ... 1250	0 ... 18	external front	3	1499 7702

Locking using Type FS CASTELL lock (not supplied)

Rating (A)	Frame size	Command	Figure N°	Reference
CD 25 ... 1250	0 ... 18	external front	2	1499 7703

Locking using XOP (not supplied)

Rating (A)	Frame size	Command	Reference
CD 25 ... 1250	0 18	external front	1499 7702

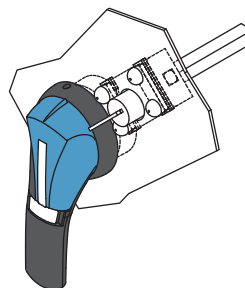

Fig. 1

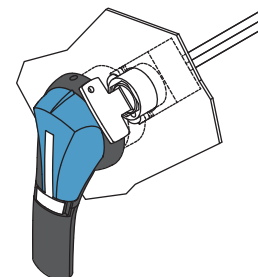

Fig. 2

access_168_a_1_x_cat

access_167_a_1_x_cat

Flat mounting kit

Use

The flat mounting kit is ideally suited to pull-out units.

Kit to be used with a handle for flat mounting.

Rating (A)	Frame size	Type	Reference
CD 25 ... CD 32	0	Kit + 200 mm shaft	1429 7709
50 - 400	11 ... 16	Kit + 200 mm shaft	1429 7710



fuser_535

Handle for flat mounting kit

Padlockable handle in position 0

Rating (A)	Frame size	Handle type	Handle colour	External IP ⁽¹⁾	Reference
CD 25 ... 63	0/11/12	S1	Black	IP55	1411 2111 ⁽²⁾
CD 25 ... 63	0/11/12	S1	Red/Yellow	IP65	1414 2111 ⁽²⁾
100 - 400	13 ... 16	S2	Black	IP55	1421 2111 ⁽²⁾
100 - 400	13 ... 16	S2	Red/Yellow	IP65	1424 2111 ⁽²⁾

(1) IP: protection index according to IEC 60529.

(2) Defeatable handle in position I.



Handle type S2

fuser_536

External front operation shaft support accessory

Use

This support maintains shaft position for extension shafts greater than 320 mm in length.

Rating (A)	Frame size	Reference
50 - 400	11 ... 16	3899 0400



fuser_698

FUSERBLOC

Front/side-control fuse combination switches

for industrial fuses up to 1250 A

Accessories (continued)

Integrated solid neutral link

Use

Fixing the solid neutral onto the mechanism produces a device with a solid neutral of the same size as a standard three-pole device (+ 6 mm).

For external front operation			
Rating (A)	Frame size	Bar rating (A)	Reference
100 ... 125	13	125	3829 9310
160	13	160	3829 9320
160	14	200	3829 9320
250	15	250	3829 9325
400	16	400	3829 9339
630 ... 800	17	800	3829 9308
800 ... 1250	18	1250	3829 9312



Solid neutral module for front control

Rating (A)	Frame size	I _{max} (A)	Distance (mm)	Reference
50	11	50	27	3629 9227
63	12	63	32	3629 9232
100 ... 160	13	160	36	3629 9236
160	14	160	50	3629 9250
250	15	250	60	3629 9260
400	16	400	66	3629 9265
630 ... 800	17	800	94	3629 9294
800 ... 1250	18	1250	120	3629 9212



Solid neutral link

NFC and DIN devices				
Rating (A)	Frame size	Fuse size	I _{max} (A)	Reference
50	11	14 x 51	50	6029 0000
100 ... 125	13	22 x 58	125	6039 0000
63 ... 160	12/13	00C / 00	160	6420 0000
160	14	0	160	6421 0000
250	15	1	250	6421 0001
400	16	2	400	6421 0002
630 ... 800	17	3	800	6421 0003
800 - 1250	18	4	1250	6441 0005

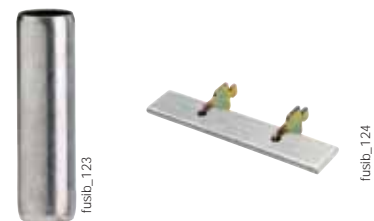

Terminal shrouds

Use

Top or bottom IP20 protection (on the front) against direct contact with terminals or connection parts.

2 sets required to fully shroud both incoming and outgoing terminals.

Rating (A)	Frame size	Position	No. of poles	Reference
CD 25 ... 63	0/12	Upstream/downstream	2 / 3 / 4 P	integrated
100 ... 160	13/14	Upstream/downstream	2 P	3998 2016
100 ... 160	13/14	Upstream/downstream	3 P	3998 3016
100 ... 160	13/14	Upstream/downstream	4 P	3998 4016
250 - 400	15	Upstream/downstream	2 P	3998 2025
250 - 400	15	Upstream/downstream	3 P	3998 3025
250 - 400	15	Upstream/downstream	4 P	3998 4025
400	16	Upstream/downstream	2 P	3898 2040
400	16	Upstream/downstream	3 P	3898 3040
400	16	Upstream/downstream	4 P	3898 4040
630 ... 800	17	Upstream/downstream	2 P	3898 2080
600 ... 800	17	Upstream/downstream	3 P	3898 3080
600 ... 800	17	Upstream/downstream	4 P	3898 4080
800 ... 1250	18	Upstream/downstream	2 P	3898 2120
800 ... 1250	18	Upstream/downstream	3 P	3898 3120
800 ... 1250	18	Upstream/downstream	4 P	3898 4120



Type S and Type ST auxiliary contacts

Use

For FUSERBLOCs 50 to 1250 A, position 0 and I signalling by 1 to 4 NO + NC auxiliary contacts.

Electrical principle

The NO + NC Type S auxiliary contacts can be configured as 2 NC or 2 NO.

Connection

By terminals with max. cross-section 10 mm².

Mechanical characteristics

30,000 operations.

References

Type S auxiliary contacts 0-I for external front and right-side operation

Rating (A)	Frame size	Contact type	Auxiliary contact type S Reference	Actuating kit for auxiliary contact (optional) Reference
50 ... 1250	11 ... 18	NC+NO	3999 0041 ⁽¹⁾	3999 0003

Type ST auxiliary contacts I-0-TEST for external front and right-side operation

Rating (A)	Frame size	Contact type	Description	Auxiliary contact type ST Reference	Actuating kit for auxiliary contact Reference
50 - 400	11 ... 16	NC+NO	TEST + ON	3999 0141 ⁽²⁾	3999 0103
50 - 400	11 ... 16	2 O	TEST + ON	3999 0241 ⁽²⁾	3999 0103

(1) Actuating kit for auxiliary contact type S signalling included.

(2) Actuating kit for auxiliary contact type ST signalling to be ordered in addition.

Characteristics

Rating (A)	Current Nominal (A)	Operating current I _e (A)	
		250 VAC AC-13	400 VAC AC-13
50 ... 1250	20	10	8



access_051



access_063

Important

> For 400 A rating, casing 16, an adaptation kit reference 3999 000 must be ordered in addition to the auxiliary contact kit.

Type U auxiliary contacts⁽¹⁾

Use

Compact universal type auxiliaries can be configured to be operated on both standard and TEST position switches. Each housing can accommodate up to 2 interlocked auxiliary contacts.

Connection to the control circuit

By terminals with max. section 2 x 2.5 mm²

For FUSERBLOC CD 25 to 400 A: pre-break and signalling of positions 0, I and Test

For FUSERBLOC ≥ 630 A: pre-break and signalling of positions 0 and I.

References

NC auxiliary contacts

Rating (A)	Frame size	Contact	Reference ⁽¹⁾
CD 25 ... 1250	0 ... 18	1	3999 0701 ⁽²⁾

NO auxiliary contacts

Rating (A)	Frame size	Contact	Reference ⁽¹⁾
CD 25 ... 1250	0 ... 18	1	3999 0702 ⁽²⁾

(1) CD 25 - CD 32: Cannot be mounted in direct operation.

(2) CD 25-160 A - 4 AC Max with no additional holder for auxiliary contact.

250-400 A - 8 AC Max with no additional holder for auxiliary contacts.

Contact holder for additional auxiliary contacts

Rating (A)	Frame size	Contact	Reference
CD 25 ... CD 32	0	4 (2 x 2 max)	3999 0710
50 - 400	11 ... 16	4 (2 x 2 max)	3999 0600

Characteristics

Rating (A)	Operating current I _e (A)			
	250 VAC AC-15	400 VAC AC-15	24 VDC DC-13	48 VDC DC-13
CD 25 ... 1250	3	1.8	2.8	1.4



access_056

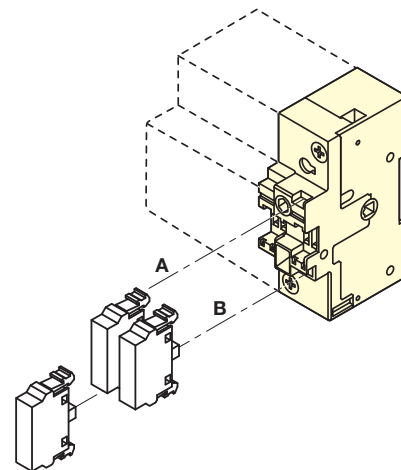

access_043_a_1_x_cat

(1) Type U auxiliary contacts cannot be mounted in conjunction with integrated solid neutral.

FUSERBLOC

Front/side-control fuse combination switches
for industrial fuses up to 1250 A

Accessories (continued)

Electronic fuse blown indication (FMD)

Use

For BS88, DIN and UL fuse cartridge, with or without striker.

Principle

The Fuse Melting Device (FMD) detects fuse blowing using a bistable relay and a signalling LED. It can be mounted on a DIN rail, a back plate, next to the FUSERBLOC, or on the door.

References

For FUSERBLOC 63 to 1250 A - size 000 to 4		
No. of LEDs	Ph/Ph operating voltage	Reference
3	155 - 260 VAC	3899 3120
3	380 - 690 VAC	3899 3380

Accessories		Reference
Kit to connect accessories	Standard	3819 9120
Kit to connect accessories	Door mounted	3829 9120

Relay characteristics		Relay operational current I _c (A)	
Rating (A)		AC-15	DC-13
63 - 1250		2.5 A	0.2



3-LED version

Important

- > For 400 A rating, casing 16, mounted on the device itself, an adaptation kit reference 3999 0000 must be ordered in addition to the FMD.

DDMM-type auxiliary contact for NFC/DIN-striking fuse device

Use

For fuse cartridge with striker (size 14 x 51; 22 x 58; 0; 1; 2; 3 and 4).

Connection to the control circuit

By 6.35 mm fast-on terminal.

Electrical principle

NO/switched neutral auxiliary contact detects fuse blowing.

Mechanical characteristics

30,000 operations.

References

NO/NC type auxiliary contacts for 2 poles				
Rating (A)	Frame size	Fusibles ⁽¹⁾	Contact	Reference
50	11	14 x 51	1 st	3994 0405
100 ... 125	13	22 x 58	1 st	3994 0210
160	14	NH0	1 st	3994 0216
250	15	NH1-NH2	1 st	3994 0225
400 ⁽¹⁾	16	NH2	1 st	3894 0440
630 ... 800	17	NH3	1 st	3894 1206
800 ... 1250	18	NH4	1 st	3894 1212

NO/NC type auxiliary contacts for 3 poles				
Rating (A)	Frame size	Fuses	Contact	Reference
CD 32	0	14 x 51	1 st	3994 0303
50	11	14 x 51	1 st	3994 0405
100 ... 125	13	22 x 58	1 st	3994 0310
160	14	NH0 - NH00	1 st	3994 0316
250	15	NH1-NH2	1 st	3994 0325
400 ⁽¹⁾	16	NH2	1 st	3894 0440
630 ... 800	17	NH3	1 st	3894 1306
800 ... 1250	18	NH4	1 st	3894 1312
50 ... 250	11/13/14/15	14x51 ... NH2	2:	3994 1901
400	16	NH2	2:	3994 1902
630 ... 1250	17/18	NH3-NH4	2:	3994 1901

NO/NC type auxiliary contacts for 4-pole or 3-pole + neutral				
Rating (A)	Frame size	Fuses	Contact	Reference
50	11	14 x 51	1 st	3994 0405
100 ... 125	13	22 x 58	1 st	3994 0410
160	14	NH0	1 st	3994 0416
250	15	NH1-NH2	1 st	3994 0425
400 ⁽¹⁾	16	NH2	1 st	3894 0440
630 ... 800	17	NH3	1 st	3894 1406
800 ... 1250	18	NH4	1 st	3894 1412
50 ... 250	11/13/14/15	14x51 ... NH2	2:	3994 1901
400	16	NH2	2:	3994 1902
630 ... 1250	17/18	NH3-NH4	2:	3994 1901

(1) NH00 fuse = size 00. NH4 fuse = size 4.

Characteristics

Rating (A)	Current Nominal (A)	Operating current I _o (A)			
		250 VAC AC-13	400 VAC AC-13	24 VDC DC-13	48 VDC DC-13
CD 32 ... 1250	16	4	3	12	2



DDMM for cylindrical fuses



DDMM for NH fuses

Cage terminals

Use

Connection of bare copper cables onto the terminals (without lugs).

References

Rating max (A)	Frame size	No. of poles	Reference
CD 25 ... 63	0 ... 12	2 / 3 / 4 P	integrated
100 ... 160	13/14	3 P	5400 3016
100 ... 160	13/14	4 P	5400 4016
250	15	3 P	5400 3025
250	15	4 P	5400 4025
400	16	3 P	5400 3040
400	16	4 P	5400 4040

Connections

Rating (A)	Cable section: flexible (mm ²)	Cable section: rigid (mm ²)	Flexible bar width (mm)	Stripped (mm)
100 ... 160	16 ... 95	16 ... 95	13	22
250	16 ... 185	16 ... 185	18	27
400	50 ... 240	50 ... 300	20	34

Dimensions

Rating (A)	A	A1	C	R	ØX	X1	Z
100 ... 160	47.5	22.5	25	20	8.5	M12	10
250	62	31.5	31.5	25	10.5	M16	14
400	71.5	32	38	32	10.5	M20	15

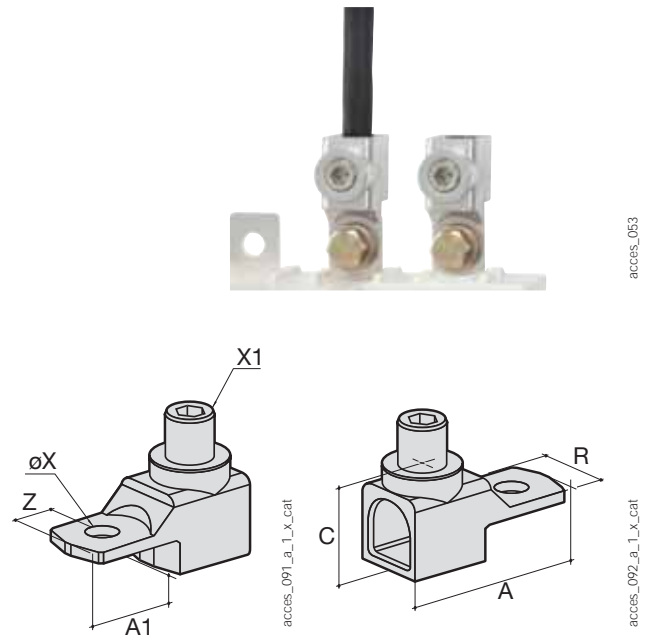

Label

Use

Customisable self-adhesive label allowing identification of the devices.

Dimensions W x H (mm)	To be ordered in multiples of	Reference
18 x 13	50	7769 9999



FUSERBLOC

Front/side-control fuse combination switches

for industrial fuses up to 1250 A

Characteristics according to IEC 60947-3

25 to 125 A

References *x* corresponds to digit for number of pole (2 = 2 P, 3 = 3 P, 6 = 4 P)	3631 x002	3631 x003	3631 x004	3831 x005	3831 x006	3831 x010	3831 x011	3831 x012	
Type	CD 25 A	CD 32 A	CD 32 A	Mod. 50 A	Mod. 63 A	Mod. 100 A	Mod. 125 A	Mod. 125 A	
Frame size	0	0	0	11	12	13	13	13	
Casing pitch per power pole (mm)	-	-	-	27	32	36	36	36	
Number of poles	3, 4(switched neutral), 4(solid neutral)	3, 4(switched neutral), 4(solid neutral)	3, 4(switched neutral), 4(solid neutral)	2, 3, 4	2, 3, 4	2, 3, 4	2, 3, 4	2, 3, 4	
Assigned thermal current I _{th} (35 °C)	25 A	32 A	32 A	50 A	63 A	100 A	125 A	125 A	
NFC/DIN fuse size	NFC 10 x 38	NFC 10 x 38	NFC 14 x 51	NFC 14 x 51	NH000	NFC 22 x 58	NFC 22 x 58	NH00	
Rated operating voltage U _e (V)	690 V	690 V	690 V	690 V	690 V	690 V	690 V	690 V	
Rated insulation voltage U _i (V)	800	800	690	800	800	800	800	800	
Rated impulse withstand voltage U _{imp} (kV)	8	8	8	8	8	8	8	8	
Short-circuit characteristics									
Prospective short-circuit current at U _e 400/415V AC (kA rms)	100	100	100	100	100	100	100	50	
Prospective short-circuit current at U _e 660/690V AC (kA rms)	100	100	-	100	100	100	100	50	
Rated peak withstand current in I _{cc} U _e 415 V AC (kA peak) (single switch)	5.5	5.5	5.5	5.52	7.3	11.9	13.6	-	
Rated peak withstand current in I _{cc} U _e 690 V AC (kA peak) (single switch)	5.2	6.1	-	6.5	7.3	15.8	20.4	10.4	
Rated operating current I_e (A)									
Nominal voltage	Operating category		A/B⁽¹⁾	A/B⁽¹⁾	A/B⁽¹⁾	A/B⁽¹⁾	A/B⁽¹⁾	A/B⁽¹⁾	A/B⁽¹⁾
415 V AC	AC 21 A / AC 21 B		25/25	32/32	32/32	50/50	63/63	100/100	125/125
415 V AC	AC 22 A / AC 22 B		25/25	32/32	32/32	50/50	63/63	100/100	125/125
415 V AC	AC 23 A / AC 23 B		25/25	32/32	32/32	50/50	63/63	100/100	125/125
500 V AC	AC 21 A / AC 21 B		25/25	32/32	32/32	50/50	63/63	100/100	125/125
500 V AC	AC 22 A / AC 22 B		25/25	32/32	32/32	50/50	63/63	100/100	125/125
500 V AC	AC 23 A / AC 23 B		25/25	32/32	32/32	50/50	63/63	100/100	125/125
690 V AC	AC 20 A / AC 20 B		25/25	32/32	32/32	50/50	63/63	100/100	125/125
690 V AC	AC 21 A / AC 21 B		25/25	32/32	32/32	50/50	63/63	100/100	125/125
690 V AC ⁽²⁾	AC 22 A / AC 22 B		25/25	32/32	32/32	50/50	63/63	100/100	125/125
690 V AC ⁽²⁾	AC 23 A / AC 23 B		25/25	32/32	32/32	50/50	63/63	100/100	125/125
220 V DC	DC 21 A / DC 21 B		-/25	-/32	-/32	-	-/63	100/100	125/125
220 V DC	DC 22 A / DC 22 B		-/25	-/32	-/32	-	-	100/100	125/125
220 V DC	DC 23 A / DC 23 B		-/25 ⁽³⁾	-/25 ⁽³⁾	-/25 ⁽³⁾	-	-	100/100	125/125
440 V DC	DC 21 A / DC 21 B		-	-	-	-	-/63 ⁽⁴⁾	100 ⁽⁴⁾ /100 ⁽⁴⁾	125 ⁽⁴⁾ /125 ⁽⁴⁾
440 V DC	DC 22 A / DC 22 B		-	-	-	-	-	100 ⁽⁴⁾ /100 ⁽⁴⁾	125 ⁽⁴⁾ /125 ⁽⁴⁾
440 V DC	DC 23 A / DC 23 B		-	-	-	-	-	100 ⁽⁴⁾ /100 ⁽⁴⁾	125 ⁽⁴⁾ /125 ⁽⁴⁾
Rated operating power in AC-23 (kW)									
At U _e 415 V AC without pre-break auxiliary contact ⁽¹⁾⁽⁵⁾	11/11	15/15	15/15	25/25	30/30	51/51	63/63	63/63	
At U _e 690 V AC without pre-break auxiliary contact ⁽¹⁾⁽⁵⁾	22/22	25/25	25/25	45/45	55/55	90/90	90/90	90/90	
Reactive power (kvar)									
At U _e 415 V AC ⁽⁵⁾	11	15	15	23	28	45	55	55	
Power dissipation (W / pole)									
Dissipated power	3.1	4.1	5.9	7.3	8.4	14.5	19.9	20.3	
Power dissipated by fuse	2.4	2.9	4.3	4.6	6	9	11	12.5	
Power dissipated by switch body	0.7	1.2	1.6	2.45	4.35	6.8	8.63	6	
Wiring capacity of conductors									
Minimum Cu cable cross-section (mm ²)	2.5	2.5	2.5	6	10	25	35	35	
Minimum Cu cable cross-section (mm ²)	16	16	16	25	25	95	95	95	
Maximum busbar width (mm)	-	-	-	-	-	20	20	20	
Min. tightening torque (Nm)	2	2	2	3	3	9	9	9	
Mechanical characteristics									
Durability (number of operating cycles)	10 000	10 000	10 000	10 000	10 000	10 000	10 000	10 000	
Operating torque (Nm)	4.1	4.1	4.1	8.7	8.7	9.7	9.7	10.2	
Weight of a 3-pole device without extras (kg)	0.48	0.48	0.50	0.80	1	1.5	1.5	1.5	
Weight of a 4-pole device without extras (kg)	0.50	0.50	0.52	1	1.3	2	2	2	
Weight of 1 P extra (kg)	-	-	-	0.2	0.3	0.5	0.5	0.5	
Storage temperature (°C)	-50 ... +85								
Operating temperature (°C)	-20 ... +70								
Regulatory compliance	IEC 60947-3								
Certification	IEC, KEMA, Lloyd's and CCC								
Degree of pollution	3	3	3	3	3	3	3	3	

(1) Category with index A = frequent operation / Category with index B = infrequent operation.

(2) With terminal shrouds or phase barrier.

(3) 3-pole device with 2 poles in series for the '+' and 1 pole for the '-'.

(4) 4-pole device with 2 poles in series per polarity.

(5) The power value is given for information only; the current values vary from one manufacturer to another.

(6) For a rated operational voltage U_e = 400 V AC.

160 to 1250 A

References <i>"x" corresponds to digit for number of pole (2 = 2 P, 3 = 3 P, 6 = 4 P)</i>	3831 x015	3831 x016	3831 x024	3831 x038	3811 x063	3811 x080	3811 x081	3811 x120
Type	Mod. 160 A	Mod. 160 A	Mod. 250 A	Mod. 400 A	Mod. 630 A	Mod. 800 A	Mod. 800 A	Mod. 1250 A
Frame size	13	14	15	16	17	17	18	18
Casing pitch per power pole (mm)	36	50	60	66	94	94	120	120
Number of poles	2, 3, 4	2, 3, 4	2, 3, 4	2, 3, 4	2, 3, 4	2, 3, 4	2, 3, 4	2, 3, 4
Assigned thermal current I _{th} (35 °C)	160 A	160 A	250 A	400 A	630 A	800 A	800 A	1250 A
NFC/DIN fuse size	NH00	NH0	NH1	NH2	NH3	NH3	NH4	NH4
Rated operating voltage U _e (V)	690 V	600 V	690 V	690 V	690 V	690 V	415 V	415 V
Rated insulation voltage U _i (V)	800	800	800	1,000	1,000	1,000	1,000	1,000
Rated impulse withstand voltage U _{imp} (kV)	8	8	8	12	12	12	12	12
Short-circuit characteristics								
Prospective short-circuit current at U _e 400/415V AC (kA rms)	50	100	100	50	100	100	100	100
Prospective short-circuit current at U _e 660/690V AC (kA rms)	50	50	50	50	100	100	-	-
Rated peak withstand current in I _{cc} U _e 415 V AC (kA peak) (single switch)	18.95	22.66	23.9	33.5	48	54.18	50.8	53.2
Rated peak withstand current in I _{cc} U _e 690 V AC (kA peak) (single switch)	13.5	14	29	29.9	58.7	58.7	-	-
Rated operating current I_e (A)								
Nominal voltage	Operating category	A/B ⁽¹⁾	A/B ⁽¹⁾	A/B ⁽¹⁾	A/B ⁽¹⁾	A/B ⁽¹⁾	A/B ⁽¹⁾	A/B ⁽¹⁾
415 V AC	AC 21 A / AC 21 B	160/160	160/160	250/250	400/400	-/630	-/800	-/800
415 V AC	AC 22 A / AC 22 B	160/160	160/160	250/250	400/400	-/630	-/800	-/800
415 V AC	AC 23 A / AC 23 B	160/160	160/160	250/250	400/400	-/630	-/800	-/800
500 V AC	AC 21 A / AC 21 B	160/160	160/160	250/250	-/400	-/630	-/800	-/800
500 V AC	AC 22 A / AC 22 B	160/160	160/160	250/250	-/400	-/630	-/800	-/800
500 V AC	AC 23 A / AC 23 B	160/160	160/160	250/250	-	-	-	-
690 V AC	AC 20 A / AC 20 B	160/160	160/160	250/250	400/400	630/630	800/800	800/800
690 V AC	AC 21 A / AC 21 B	160/160	160/160	250/250	-/400	-/630	-/800	-/800
690 V AC ⁽²⁾	AC 22 A / AC 22 B	160/160	160/160	250/250	-/400	-/630	-/800 ⁽⁶⁾	-/800
690 V AC ⁽²⁾	AC 23 A / AC 23 B	125/125	125/125	250/250	250/315	-	-	-
220 V DC	DC 21 A / DC 21 B	160/160	160/160	250/250	-	-	-	-
220 V DC	DC 22 A / DC 22 B	160/160	160/160	250/250	-	-	-	-
220 V DC	DC 23 A / DC 23 B	125/125	125/125	200/200	-	-	-	-
440 V DC	DC 21 A / DC 21 B	160 ⁽³⁾ /160 ⁽³⁾	160 ⁽³⁾ /160 ⁽³⁾	250 ⁽³⁾ /250 ⁽³⁾	-	-	-	-
440 V DC	DC 22 A / DC 22 B	160 ⁽³⁾ /160 ⁽³⁾	160 ⁽³⁾ /160 ⁽³⁾	250 ⁽³⁾ /250 ⁽³⁾	-	-	-	-
440 V DC	DC 23 A / DC 23 B	125 ⁽³⁾ /125 ⁽³⁾	125 ⁽³⁾ /125 ⁽³⁾	200 ⁽³⁾ /200 ⁽³⁾	-	-	-	-
Rated operating power in AC-23 (kW)								
At U _e 415 V AC without pre-break auxiliary contact ⁽¹⁾⁽⁵⁾		80/80	80/80	132/132	220/220	355/355	450/450	450/450
At U _e 690 V AC without pre-break auxiliary contact ⁽¹⁾⁽⁵⁾		110/110	110/110	220/220	220/295	295/400	400/400	400/475
Reactive power (kvar)								
At U _e 415 V AC ⁽⁵⁾		75	75	115	185	290	365	355
Power dissipation (W / pole)								
Power dissipation		21.6	23	41.1	57.4	122	134	264
Power dissipated by fuse		12	15	23	33	60	65	110
Power dissipated by switch body		10.4	10.4	19	24.4	61	68	154
Wiring capacity of conductors								
Minimum Cu cable cross-section (mm ²)		35	50	95	185	2 x 150	2 x 185	
Minimum Cu cable cross-section (mm ²)		95	95	240	240	2 x 300	2 x 300	4 x 185
Maximum busbar width (mm)		20	20	32	45	63	63	80
Min. tightening torque (Nm)		9	9	20	20	40	40	40
Mechanical characteristics								
Durability (number of operating cycles)		10 000	10 000	10 000	10 000	5 000	8 000	3 000
Operating torque (Nm)		10.2	9.7	13	17	56	57	62
Weight of a 3-pole device without extras (kg)		1.8	1.8	3.2	4.8	16	17	25
Weight of a 4-pole device without extras (kg)		2.3	2.3	4.5	6.1	20	21.5	30
Weight of 1 P extra (kg)		0.5	0.5	1.3	1.3			3
Storage temperature (°C)		-50 ... +85						
Operating temperature (°C)		-20 ... +70						
Regulatory compliance		IEC 60947-3						
Certification		IEC, KEMA, Lloyd's and CCC						
Degree of pollution		3	3	3	3	3	3	3

(1) Category with index A = frequent operation / Category with index B = infrequent operation.

(2) With terminal shrouds or phase barrier.

(3) 3-pole device with 2 poles in series for the '+' and 1 pole for the '-'.
(4) 4-pole device with 2 poles in series per polarity.

(5) The power value is given for information only; the current values vary from one manufacturer to another.

(6) For a rated operational voltage U_e = 400 VAC.

FUSERBLOC

Front/side-control fuse combination switches
for industrial fuses up to 1250 A

Dimensions for front/side external operation

25 to 32 A (size 10 x 38)

External front operation

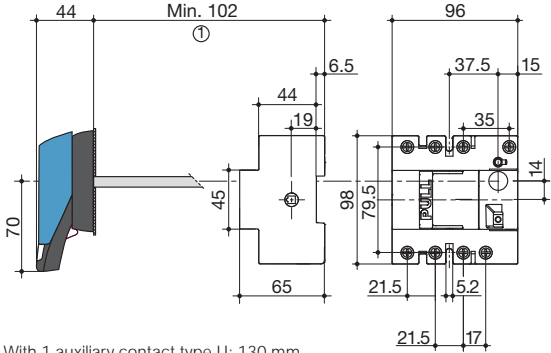

- 1. With 1 auxiliary contact type U: 130 mm.
- With 2 auxiliary contacts type U: 155 mm.

External side operation

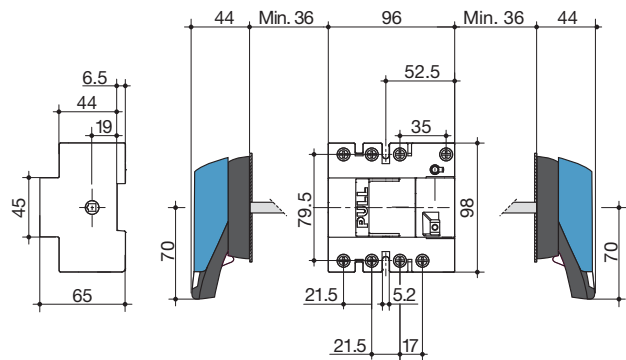

32 A (size 14 x 51)

External front operation

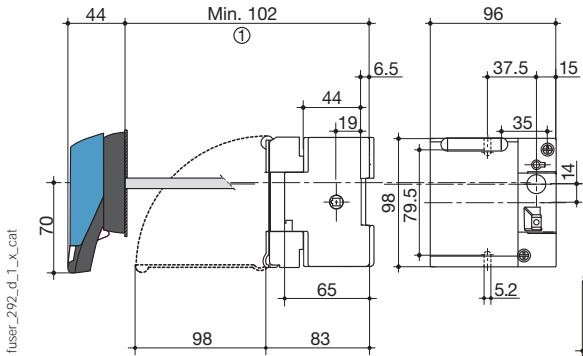

- 1. With 1 auxiliary contact type U: 130 mm.
- With 2 auxiliary contacts type U: 155 mm.

External side operation

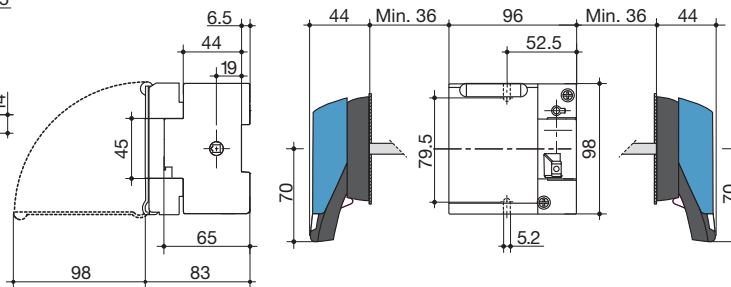

Dimensions - direct operation

25 A (size 10 x 38)

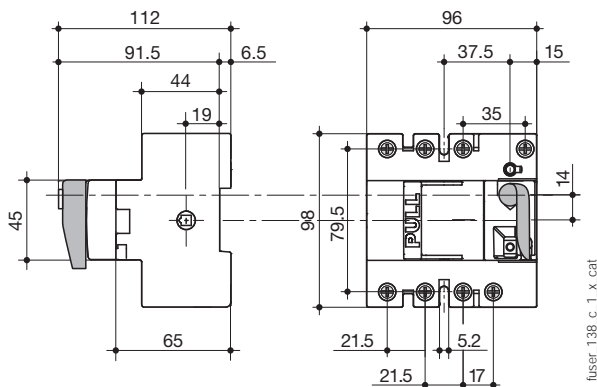

32 A (size 14 x 51)

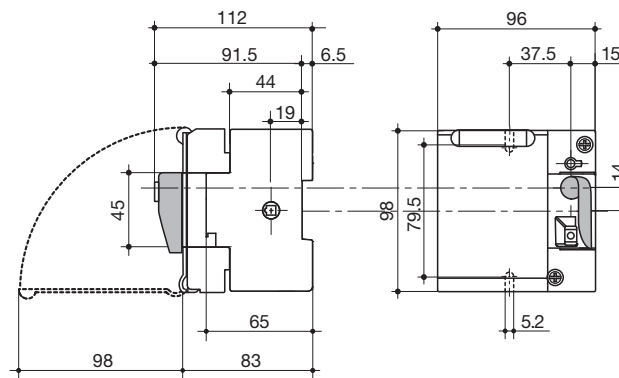

Dimensions for direct front and front/side external operation

50 to 160 A

50 - 63 A: cage connection.

100 - 160 A: cage connection.

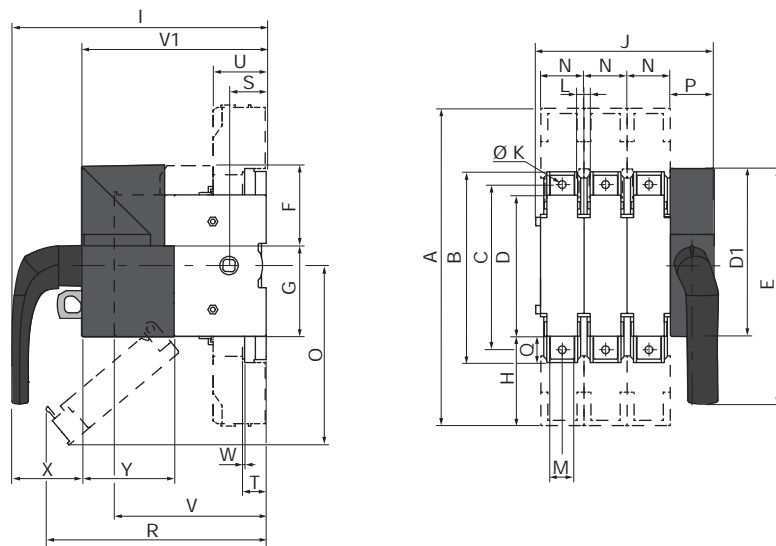
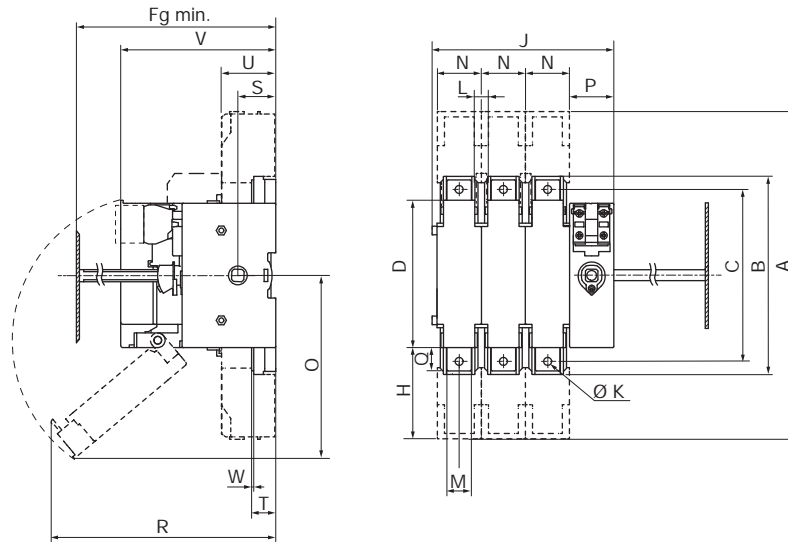

fuser_751_a_1_x_cat.ai

fuser_752_a_1_x_cat.ai

Rating (A)	Fuse size	Frame size	Fg min.	A	B	C	D	D1	E	F	G	H	I	J										U	V	V1	W	X	Y		
														3P	4P	K	L	M	N	O	P	Q	R							S	T
50	14 x 51	11	100		118		106	143	200	67.5	75.5		212.1	121	148	6.2	15	12	27	85	36.8	15	153	31			87	153.6	2	58.5	77
63	00C	12	125		118		106	143	200	67.5	75.5		212.1	136	168	6.2	20	12	32	159	36.8	15	145	31			116	153.6	2	58.5	77
100	22x58	13	135	268	162	141	127	143	200	67.5	75.5	75	212.1	148	184	8.5	16	20	36	141	36.8	41	187	31	19.5	43.5	116	153.6	2.5	58.5	77
125	22x58	13	135	268	162	141	127	143	200	67.5	75.5	75	212.1	148	184	8.5	16	20	36	141	36.8	41	179	31	19.5	43.6	116	153.6	2.5	58.5	77
125	NH00	13	135	268	162	141	127	143	200	67.5	75.5	75	212.1	148	184	8.5	16	20	36	141	36.8	41	193	31	19.5	43.7	126	153.6	2.5	58.5	77
160	NH00	13	135	268	162	141	127	143	200	67.5	75.5	75	212.1	148	184	8.5	16	20	36	141	36.8	41	193	31	19.5	43.8	126	153.6	2.5	58.5	77
160	NH0	14	145	268	162	141	140	143	200	67.5	75.5	75	212.1	190	240	8.5	20	20	50	174	36.8	41	229	31	19.5	43.9	136	153.6	2.5	58.5	77

FUSERBLOC

Front/side-control fuse combination switches
for industrial fuses up to 1250 A

Dimensions for direct front and front/side external operation (continued)

250 A

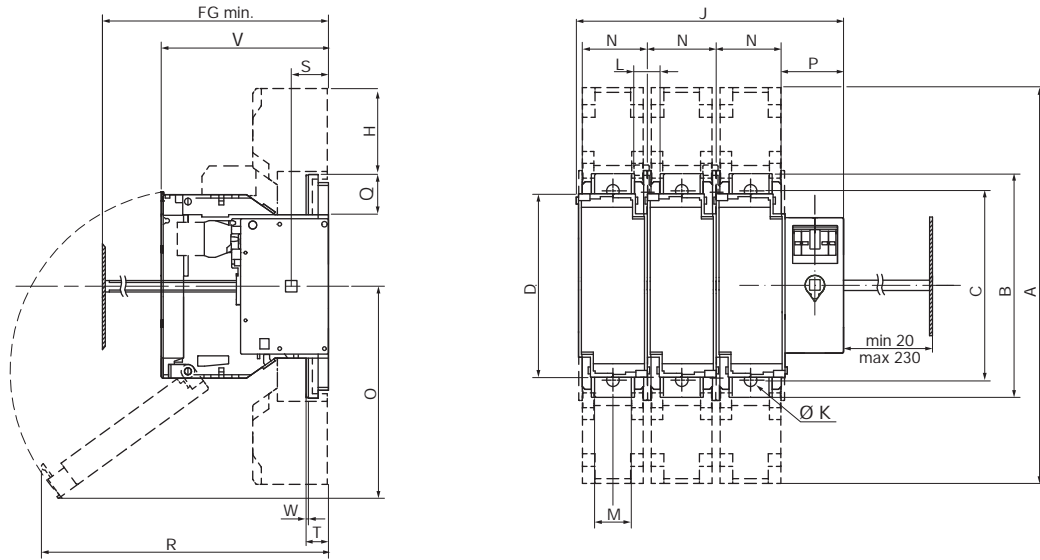

fuser_748_a_1_x_cat.ai

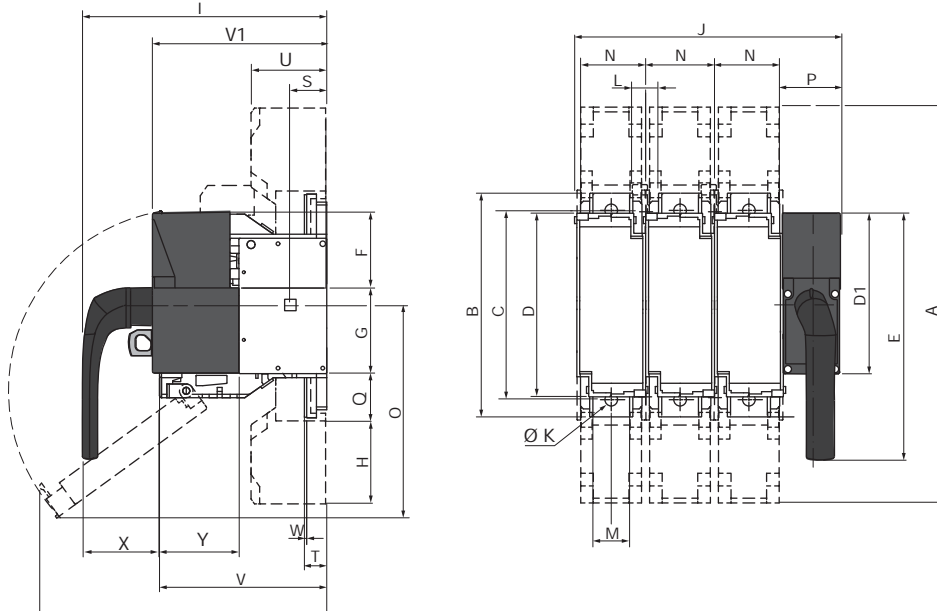

fuser_749_a_1_x_cat.ai

Rating (A)	Fuse size	Frame size	Fg min.	J																											
				A	B	C	D	D1	E	F	G	H	I	3P	4P	K	L	M	N	O	P	Q	R	S	T	U	V	V1	W	X	Y
250	NH1	15	154	345	195	166	162	143	220	67.5	75.5	110	212.1	234	294	8.5	28	32	60	185	51.6	52	251	31	19.5	65	146	142	2.5	58.5	77

400 A

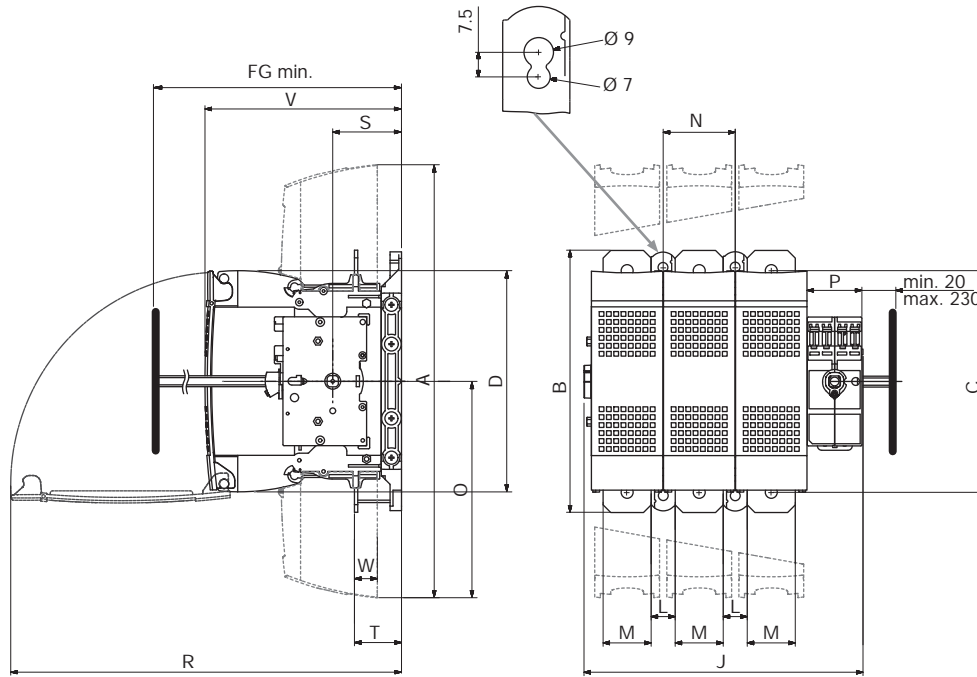

fuser_733_c_1_x_cat.ai

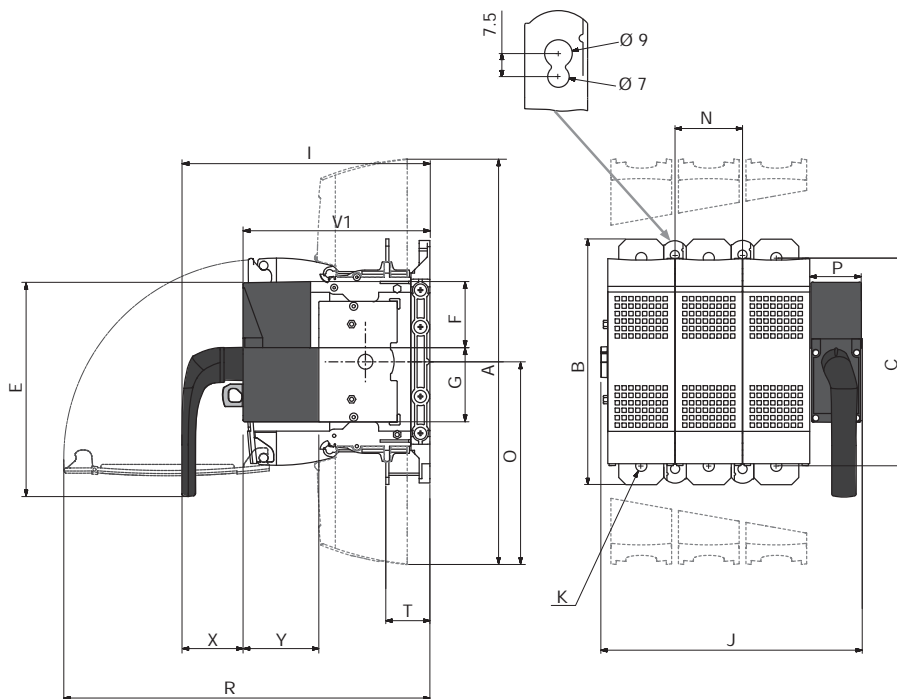

fuser_750_a_1_x_cat.ai

Rating (A)	Fuse size	Frame size	Fg min.	A	B	C	D	D1	E	F	G	I	J		K	L	M	N	O	P	R	S	T	V	V1	W	X	Y
													3P	4P														
400	NH2	16	188	397	240	203	203	143	220	67.5	75.5	239	256	321	11	34	32	66	199	50	360	63	43	180	184	3	58.5	77

FUSERBLOC

Front/side-control fuse combination switches
for industrial fuses up to 1250 A

Dimensions for direct and external operation

630 to 1250 A

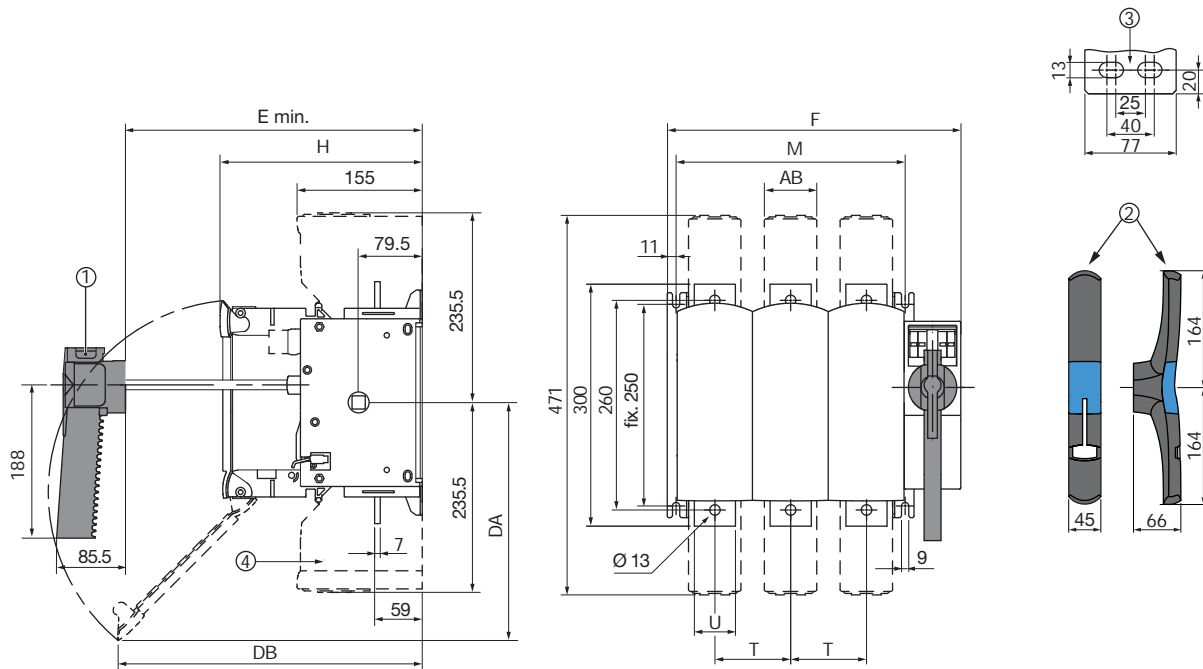

1. Handle for casing size 17.
2. Handle for casing size 18.
3. Connection terminals for casing size 18.
4. Terminal cover.

fuser_4115_1_x_cat.ai

Rating (A)	Fuse size	Frame size	Overall dimensions	Case					Switch mounting		Connection		Terminal shrouds
				E min.	F 3 P	F 4 P	H	DA	DB	M 3p.	M 4p.	T	
630	3	17	265	364	458	250	300	380	284	378	94	51	65
800	3	17	265	364	458	250	300	380	284	378	94	51	65
800	4	18	304	442	562	289	355	295	362	482	120	77	88
CD 1250	4	18	304	442	562	289	355	295	362	482	120	77	88

Dimensions for external handles

25 to 32 A

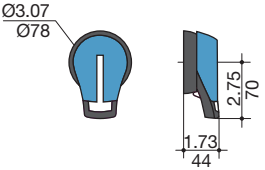
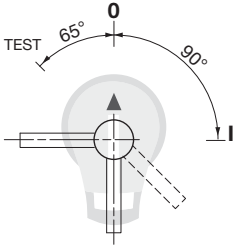
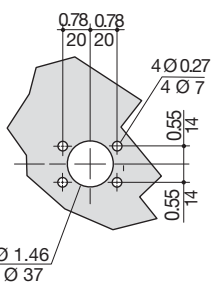
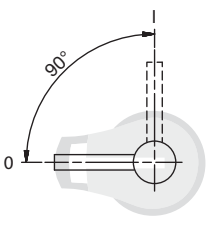
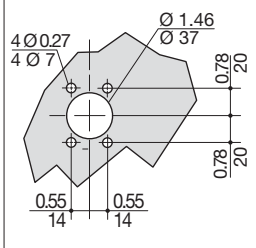
Handle type	Front operation		Side operation	
	Direction of operation	Door drilling	Direction of operation	Door drilling
S1 type Box size 0 				

50 to 400 A

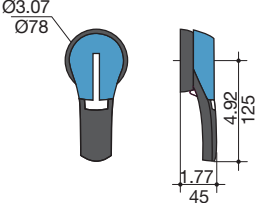
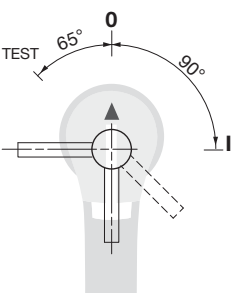
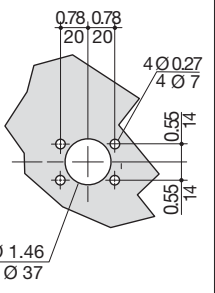
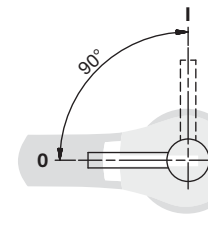
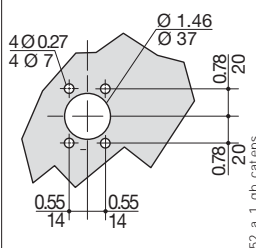
Handle type	Front operation		Side operation	
	Direction of operation	Door drilling	Direction of operation	Door drilling
S2 type Box size 11-16 				

630 to 800 A

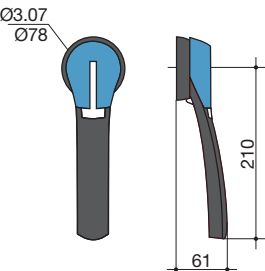
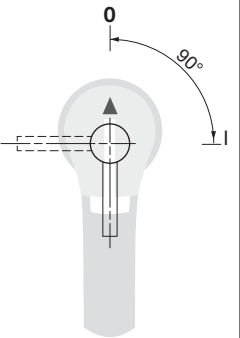
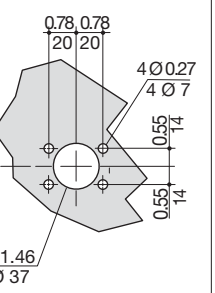
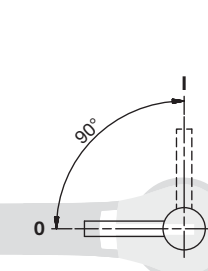
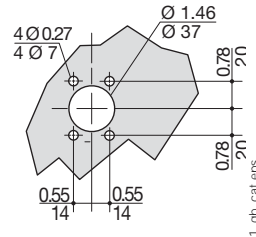



Handle type	Front operation		Side operation	
	Direction of operation	Door drilling	Direction of operation	Door drilling
S3 type Box size 17 				

FUSERBLOC

Front/side-control fuse combination switches
for industrial fuses up to 1250 A

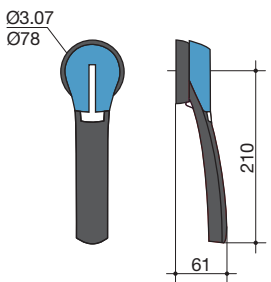
Dimensions for external handles (continued)

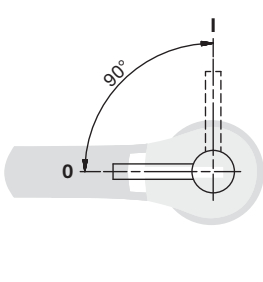
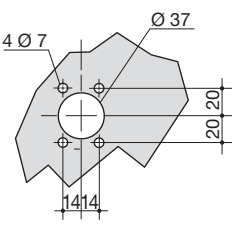
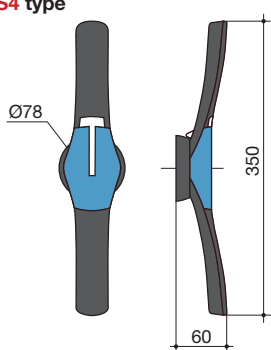
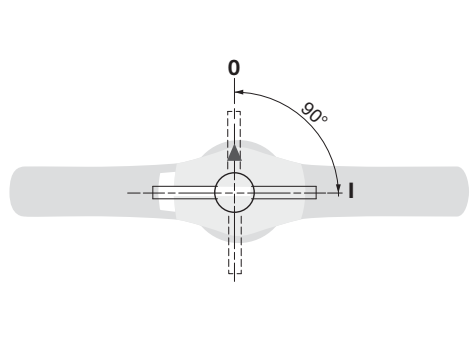
800 to 1250 A

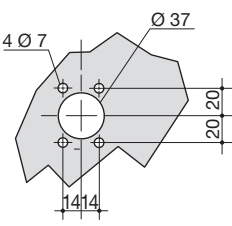
Handle type	Front operation Direction of operation	Side operation Direction of operation	Door drilling
S3 type Box size 18 			
S4 type 			

peign_054_a_1_gb_cat.eps

Dimensions for direct-control casings

50 to 400 A

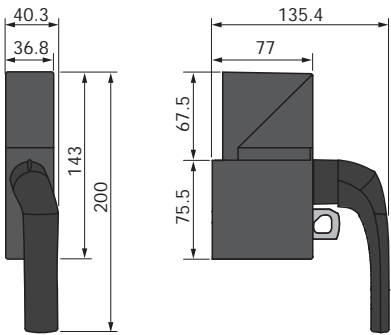
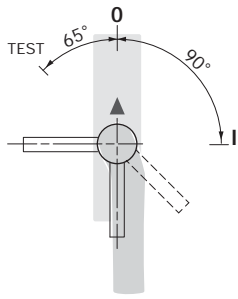
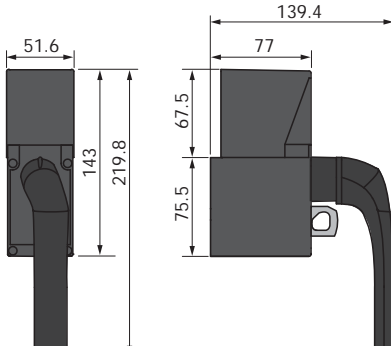
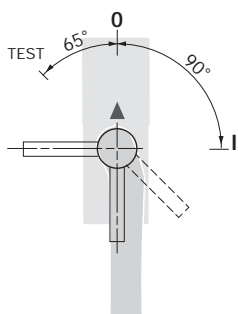
Case handle type	Direct control Operating direction
<p>50 to 160 A Case 11 to 14</p> 	
<p>250 to 400 A Case 15 to 16</p> 	

fuser_753_a_1_en_cat.ai

FUSERBLOC and high speed fuses (uR)

Fuse load break switches

Protection for power semiconductors up to 1250 A



FUSERBLOC
630 to 1250 A



FUSERBLOC
from 25 to 400 A

The solution for

- > Protection for inverters and variable speed drives



Strong points

- > Limiting the short-circuit current

Extended range

- > For different setups, please contact us (uR 1250 V fuses, 80 mm or 110 mm size notch fuses, different sizes, etc.).

Function

FUSERBLOC fuse combination switches combined with high speed fuses (uR curve) ensure the best operation under load, safe switching and protection for your power semiconductors (dimmers, inverters, etc.).

Advantages

Limiting the short-circuit current

This fuse solution for limiting the short-circuit current is by far the most efficient and economical on the market (uR fuses)

FUSERBLOC and high speed fuses (uR)

Fuse combination switches

Protection for power semiconductors up to 1250 A

FUSERBLOC for cylindrical uR 690 VAC fuses

Characteristics

FUSERBLOC CD 50 A for 14 x 51 fuses									
Fuse rating (A)	10	12	16	20	25	32	40	50	
I max. for FUSERBLOC (A)	10	12	16	20	25	29	36	40	
FUSERBLOC CD 125 A for 22 x 58 fuses									
Fuse rating (A)	20	25	32	40	50	63	80	100	
I max. for FUSERBLOC (A)	20	25	32	40	50	63	71	85	

References

Direct side operation

Rating (A) / Fuse size / Casing size	No. of poles	Case	Direct handle	Auxiliary contact for pre-break and position signalling
50 A / 14 x 51 1	2 P	3615 2005	Black 3629 7900	1 contact NO/NC 3999 0021
	3 P	3615 3005		
	4 P	3615 6005		
125 A / 22 x 58 3	2 P	3615 2011	Black 3629 7901	2 contacts NO/NC 3999 0022
	3 P	3615 3011		
	4 P	3615 6011		

Front or right-side external controls

Rating (A) / Fuse size / Casing size	No. of poles	Case	External front handle	External side handle	Shaft for external operation	Auxiliary contact for pre-break and position signalling
50 A / 14 x 51 11	2 P	3831 2005	Black IP55 1411 2111	Black IP55 1415 2111	320 mm 1400 1032	1 contact NC 3999 0701
	3 P	3831 3005	Red/Yellow IP65 1414 2111	Red / Yellow IP65 1418 2111		
	4 P	3831 6005				
125 A / 22 x 58 13	2 P	3831 2011	Black IP55 1421 2111	Black IP55 1425 2111		1 contact NO 3999 0702
	3 P	3831 3011	Red IP65 1424 2111	Red/Yellow IP65 1428 2111		
	4 P	3831 6011				

Accessories

For other accessories, see FUSERBLOC.

FUSERBLOC and high speed fuses (uR)

Fuse combination switches

Protection for power semiconductors up to 1250 A

FUSERBLOC for 690 V AC uR solid knife blade fuses DIN 43620

Characteristics

FUSERBLOC 160 A for fuses size 000 and 00															
Fuse rating (A)	10	16	20	25	32	40	50	63	80	100	125	160	200	250	315
I max. for FUSERBLOC (A)	10	16	20	25	32	32	37	44	51	92	105	121	140	140	140
FUSERBLOC 250 A for fuses size 1*															
Fuse rating (A)				40	50	63	80	100	125	160	200	250	315	350	400
I max. for FUSERBLOC (A)				40	50	63	80	100	125	155	178	205	210	215	220
FUSERBLOC 400 A for fuses size 2															
Fuse rating (A)						200	250	315	350	400	450	500	550	630	700
I max. for FUSERBLOC (A)						120	150	169	210	330	330	340	340	350	350
FUSERBLOC 630 A for fuses size 3															
Fuse rating (A)									500	550	630	700	800	900	1000
I max. for FUSERBLOC (A)									360	380	420	450	480	500	510

References

Direct side operation

Rating (A) / Fuse / Casing size	No. of poles	Case	Direct handle	Pre-break Auxiliary contact and position	Fuse caps		
160 A / 00 3	2 P	3615 2015	Black 3629 7901	1 contact NO/NC 3999 0021	3990 7015 ⁽¹⁾		
	3 P	3615 3015			3990 8015 ⁽¹⁾		
	4 P	3615 6015			3990 9015 ⁽¹⁾		
160 A / 0 4	2 P	3615 2016			3990 7016 ⁽¹⁾		
	3 P	3615 3016			3990 8016 ⁽¹⁾		
	4 P	3615 6016			3990 9016 ⁽¹⁾		
250 A / 1 5	2 P	3615 2024		2 NO/NC contacts 3999 0022	3990 7024 ⁽¹⁾		
	3 P	3615 3024			3990 8024 ⁽¹⁾		
	4 P	3615 6024			3990 9024 ⁽¹⁾		
400 A / 2 6	2 P	3615 2039			3990 7039 ⁽¹⁾		
	3 P	3615 3039			3990 8039 ⁽¹⁾		
	4 P	3615 6039			3990 9039 ⁽¹⁾		
630 A / 3 17	2 P	3811 2063	Black 3899 6011	1 contact NC 3999 0701	3990 7063 ⁽¹⁾		
	3 P	3811 3063			3890 8063 ⁽¹⁾		
	4 P	3811 6063		3890 9063 ⁽¹⁾			
160 A / 00 13	2 P	3831 2015		Black IP55 1421 2111	200 mm 1400 1020	3990 7015 ⁽¹⁾	
	3 P	3831 3015				3990 8015 ⁽¹⁾	
	4 P	3831 6015				3990 9015 ⁽¹⁾	
160 A / 0 14	2 P	3831 2016	3990 7016 ⁽¹⁾				
	3 P	3831 3016	3990 8016 ⁽¹⁾				
	4 P	3831 6016	3990 9016 ⁽¹⁾				
250 A / 1 15	2 P	3831 2024	Red/Yellow IP65 1424 2111		320 mm 1400 1032	3990 7024 ⁽¹⁾	
	3 P	3831 3024				3990 8024 ⁽¹⁾	
	4 P	3831 6024			3990 9024 ⁽¹⁾		
400 A / 2 16	2 P	3831 2039			Black IP65 1433 3111	1 contact NC 3999 0701	3990 7039 ⁽¹⁾
	3 P	3831 3039					3990 8039 ⁽¹⁾
	4 P	3831 6039				3990 9039 ⁽¹⁾	
630 A / 3 17	2 P	3811 2063	Red/Yellow IP65 1434 3111	200 mm 1400 1220		3990 7063 ⁽¹⁾	
	3 P	3811 3063				3890 8063 ⁽¹⁾	
	4 P	3811 6063		3890 9063 ⁽¹⁾			

(1) Terminal shrouds for FUSERBLOC devices equipped with auxiliary contacts for fuse blown signal.

External right-side or front control

Rating (A) / Fuse / Casing size	No. of poles	Case	External front handle	External side handle	Shaft for external operation	Auxiliary contact for pre-break and position signalling	Fuse caps	
160 A / 00 13	2 P	3831 2015	Black IP55 1421 2111	Black IP55 1425 2111	200 mm 1400 1020	1 contact NC 3999 0701	3990 7015 ⁽¹⁾	
	3 P	3831 3015					3990 8015 ⁽¹⁾	
	4 P	3831 6015					3990 9015 ⁽¹⁾	
160 A / 0 14	2 P	3831 2016					3990 7016 ⁽¹⁾	
	3 P	3831 3016					3990 8016 ⁽¹⁾	
	4 P	3831 6016					3990 9016 ⁽¹⁾	
250 A / 1 15	2 P	3831 2024		Red/Yellow IP65 1424 2111	320 mm 1400 1032	1 contact NC 3999 0701	3990 7024 ⁽¹⁾	
	3 P	3831 3024					3990 8024 ⁽¹⁾	
	4 P	3831 6024			3990 9024 ⁽¹⁾			
400 A / 2 16	2 P	3831 2039			Black IP65 1433 3111	1 contact NC 3999 0701	200 mm 1400 1220	3990 7039 ⁽¹⁾
	3 P	3831 3039						3990 8039 ⁽¹⁾
	4 P	3831 6039				3990 9039 ⁽¹⁾		
630 A / 3 17	2 P	3811 2063	Red/Yellow IP65 1434 3111	320 mm 1400 1232		1 contact NO 3999 0702	3990 7063 ⁽¹⁾	
	3 P	3811 3063					3890 8063 ⁽¹⁾	
	4 P	3811 6063		3890 9063 ⁽¹⁾				

(1) Terminal shrouds for FUSERBLOC devices equipped with auxiliary contacts for fuse blown signal.

FUSERBLOC and high speed fuses (uR)

Fuse combination switches

Protection for power semiconductors up to 1250 A

Accessories

Terminal shrouds for FUSERBLOC devices equipped with auxiliary contacts for fuse blown signal.

Use

Protection from direct contact with live parts located in the fuse compartment, for FUSERBLOC devices equipped with uR fuses with auxiliary contacts for fuse blown signal.

Rating (A)	Fuses ⁽¹⁾	No. of poles	Option ⁽²⁾ (factory fit)		Accessories ⁽³⁾ (client fit)	
			References	References	References	References
160	00	2 P	3990 7015		3999 7015	
160	00	3 P	3990 8015		3999 8015	
160	00	4 P	3990 9015		3999 9015	
160	0	2 P	3990 7016		3999 7016	
160	0	3 P	3990 8016		3999 8016	
160	0	4 P	3990 9016		3999 9016	
250	1	2 P	3990 7024		3999 7024	
250	1	3 P	3990 8024		3999 8024	
250	1	4 P	3990 9024		3999 9024	
400	2	2 P	3990 7039		3999 7039	
400	2	3 P	3990 8039		3999 8039	
400	2	4 P	3990 9039		3999 9039	
630	3	3 P	3890 8063		3899 8063	
630	3	4 P	3890 9063		3899 9063	

(1) For fuses, see "uR fuses 10 to 2000 A".

(2) If ordered with the main device.

(3) If otherwise controlled.

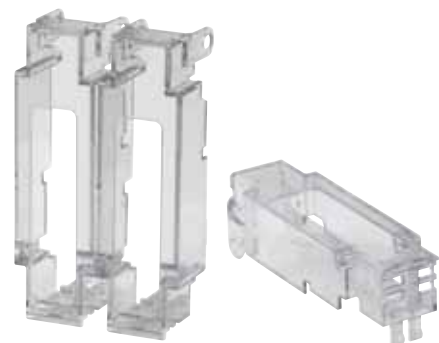

access_221_a

For other accessories, see FUSERBLOC.

FUSERBLOC for 690 V AC uR type K/50 fuses

Characteristics

FUSERBLOC V 800 A for BK size 2 fuse														
Fuse rating (A)	400	450	500	550	630	700	800	900	1000	1100	1250			
I max. for FUSERBLOC (A)	380	420	440	450	500	520	530	530	530	540	550			
FUSERBLOC 1250 A for fuses size 3														
Fuse rating (A)	500	550	630	700	800	900	1000	1100	1250	1400	1500	1600	1800	2000
I max. for FUSERBLOC (A)	500	550	620	630	720	790	870	940	1050	1100	1100	1100	1100	1100

References

Front operation

Rating (A) / Fuse	No. of poles	Switch body ⁽¹⁾	Direct handle	External handle	Shaft for external operation	Fuse caps	Auxiliary contact for pre-break and position signalling	Terminal shrouds
800 A / 2	3 P	3680 3081	3999 6012	Black IP55 1443 3111 ⁽²⁾ Red/Yellow IP65 1444 3111	200 mm 1400 1220 320 mm 1400 1232	included	1 NO/NC 3999 0051 2e NO/NC 3999 0052	3998 3063
	4 P	3680 6081						3998 4063
1250 A / 3	3 P	3680 3121						3998 3120
	4 P							3998 4120

(1) Please contact us.

(2) Standard.

FUSERBLOC and high speed fuses (uR)

Fuse combination switches

Protection for power semiconductors up to 1250 A

FUSERBLOC for K/110 uR fuses

Characteristics

FUSERBLOC 250 A for fuses size 1* at 690 VAC ⁽¹⁾																		
Fuse rating (A)	40	50	63	80	100	125	160	200	250	315	350	400	450	500	550	630		
I max. for FUSERBLOC (A)	40	50	63	80	100	120	140	165	195	215	230	240	240	240	230	240		
FUSERBLOC 400 A for fuses size 1* at 690 VAC ⁽¹⁾																		
Fuse rating (A)							200	250	315	350	400	450	500	550	630	700	800	900
I max. for FUSERBLOC (A)							145	165	200	220	240	265	290	310	340	370	395	395
FUSERBLOC 500 A for fuses size 2* at 690 VAC ⁽¹⁾																		
Fuse rating (A)											400	450	500	550	630	700		
I max. for FUSERBLOC (A)											320	345	370	390	425	460		
FUSERBLOC 630 A for fuses size 2 at 690 VAC ⁽¹⁾																		
Fuse rating (A)											800	900	1000	1100	1250			
I max. for FUSERBLOC (A)											495	545	590	610	620			
FUSERBLOC 800 A for fuses size 3 at 690 VAC ⁽¹⁾																		
Fuse rating (A)			500	550	630	700	800	900	1000	1100	1250	1400	1500	1600	1800	2000		
I max. for FUSERBLOC (A)			370	395	440	480	535	590	645	695	760	800	800	800	800	800		
FUSERBLOC 1250 A for fuses size 3, contact us.																		

⁽¹⁾ For uR fuses type K/110 1250 VAC, please contact us.

References

Direct right-side or front control

Rating (A) / Fuse / Casing size	No. of poles	Case	Direct side handle	Direct front handle	Fuse caps	Auxiliary contact for pre-break and position signalling	Terminal shrouds				
250 A / 1* / 6	2 P	36U1 2024	Black 3629 7901		2 P	1 contact NO/NC 3999 0021	2 P				
	3 P	36U1 3024			3 P		3998 2025				
400 A / 1 / 6	2 P	36U1 2039			3 P		3998 3025				
	3 P	36U1 3039									
500 A / 2 / 17	2 P	38U1 2050	Black 1437 7911	Black 3899 6011	2 P 3890 2U63 ⁽¹⁾ 3 P 3890 3U63 ⁽¹⁾	1 contact NC 3999 0701 1 contact NO 3999 0702	2 P				
	3 P	38U1 3050					3 P	3898 2080			
630 A / 2 / 17	2 P	38U1 2063					3 P	3898 3080			
	3 P	38U1 3063									
800 A / 3 / 18	2 P	38U1 2080					Black 3899 7011	Standard			3 P
	3 P	38U1 3080									3 P
1250 A / 3 / 18	2 P	38U1 2120					3898 2120				
	3 P	38U1 3120					3898 3120				

⁽¹⁾ Terminal shrouds for FUSERBLOC devices equipped with auxiliary contacts for fuse blown signal.

Part numbers (continued)

External right-side or front control

Rating (A) / Fuse size / Casing size	No. of poles	Case	External front handle	External side handle	Shaft for external operation	Fuse caps	Auxiliary contact for pre-break and position signalling	Terminal shrouds				
250 A / 1* / 16	2 P	38U1 2024	Type S2 Black IP55 1421 2111	Type S2 Black IP55 1425 2111	320 mm 1400 1032	2 P 3990 2839 ⁽¹⁾		2 P 3998 2025				
	3 P	38U1 3024							3 P 3998 3025			
400 A / 1 / 16	2 P	38U1 2039	Red IP65 1424 2111	Red/Yellow IP65 1428 2111		3 P 3990 3839 ⁽¹⁾						
	3 P	38U1 3039								3 P 3998 3025		
500 A / 2 / 17	2 P	38U1 2050	Type S3 Black IP65 1433 3111	Type S3 Black IP65 1437 3111	320 mm 1400 1232		1 contact NC 3999 0701 1 contact NO 3999 0702					
	3 P	38U1 3050							2 P 3898 2080			
630 A / 2 / 17	2 P	38U1 2063				Red/Yellow IP65 1434 3111		Type S3 Black IP65 1437 3111		2 P 3890 2U63 ⁽¹⁾		2 P 3898 2080
	3 P	38U1 3063										
800 A / 3 / 17	2 P	38U1 2080	Type S4 Black IP65 1443 3111	Red/Yellow IP65 1438 3111								
	3 P	38U1 3080							2 P 3898 2120			
1250 A / 3 / 18	2 P	38U1 2120				Red/Yellow IP65 1444 3111				Standard		2 P 3898 2120
	3 P	38U1 3120										

(1) Terminal shrouds for FUSERBLOC devices equipped with auxiliary contacts for fuse blown signal.

Accessories

Terminal shrouds for FUSERBLOC devices equipped with auxiliary contacts for fuse blown signal.

Use

Protection from direct contact with live parts located in the fuse compartment, for FUSERBLOC devices equipped with uR fuses with auxiliary contacts for fuse blown signal.

Rating (A)	Fusibles ⁽³⁾	No. of poles	Option ⁽²⁾	Accessories ⁽¹⁾
			(factory fit) Reference	(client fit) Reference
250 - 400	1* / 1	2 P	3990 2839	3999 2839
250 - 400	1* / 1	3 P	3990 3839	3999 3839
500 ... 800	2 / 3	2 P	3890 2U63	3899 2U63
500 ... 800	2 / 3	3 P	3890 3U63	3899 3U63
500 ... 800	2 / 3	2 P	3890 2U63	3899 2U63
1250	3	2 P	Standard	Standard
1250	3	3 P	Standard	Standard

(1) If otherwise controlled.

(2) If ordered with the main device.

(3) For fuses, see "uR fuses 10 to 2000 A".

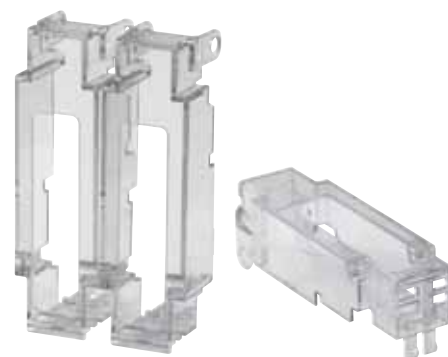

access_221_a

For other accessories, see FUSERBLOC.

FUSERBLOC LMDC

Fuse combination switches

FUSERBLOC Live Maintenance DC



The solution for

- > Live maintenance of speed drives supplied by a common DC bus
- > Live maintenance of PV inverters connected in parallel on a same circuit



Strong points

- > Compact
- > Automatic pre-load
- > Integrated fuse protection

Conformity to standards

- > IEC 60947-3

Function

FUSERBLOCs LMDC are designed to perform the maintenance of DC/AC speed drives or PV inverters without stopping the entire installation. This multifunctional device for performing maintenance work on a branch of the electrical system while leaving the rest of the equipment energised. FUSERBLOCs LMDC ensure a safe charge of capacitive loads by limiting high inrush current during power-up of the branch and thus reducing stress to components.

Advantages

Compact

Isolation, protection and precharge of capacitive loads within a single device.

Automatic pre-load

After maintenance operations, the pre-load of inverters capacitors will be managed automatically through a coil.

Integrated fuse protection

Semiconductors protection is integrated to the switch (no additional space is required).

Characteristics

- 125 to 1600 A
- DC20

References

External / direct operation 125 to 1600 A

Rating (A)	No. of main poles	Fuse size of main poles	Pre-charge poles (DIN 43620)	Reference	External front handle	Direct front handle	Shaft for external front handle	Auxiliary contacts	Terminal shrouds ⁽⁵⁾ Main poles	Terminal shrouds Pre-load poles
125 A	2	DIN 43620 00	2 x 160 A Size 00	38DR 2012 ⁽¹⁾⁽²⁾	S3 type Black IP65 1433 3111	Black 3899 6011	200 mm 1400 1220	U type 1 contact NC 3999 0701 ⁽³⁾	3998 2016 ⁽⁴⁾	3998 2016
160 A	2	DIN 43620 1	2 x 160 A Size 00	38DR 2016 ⁽¹⁾⁽²⁾					3998 2025 ⁽⁴⁾	
250 A	2	DIN 43620 2	2 x 160 A Size 00	38DR 2025 ⁽¹⁾⁽²⁾	Red/Yellow IP65 1434 3111	320 mm 1400 1232	1 contact NO 3999 0702 ⁽³⁾	3898 2080		
400 A	2	DIN 43620 3	2 x 160 A Size 00	38DR 2040 ⁽¹⁾⁽²⁾				3898 2120		
630 A	2	DIN 43620 3	2 x 160 A Size 00	38DR 2063 ⁽¹⁾⁽²⁾	S4 type Black IP65 1443 3111	Black 3899 7011	500 mm 1400 1250	3898 2150		
900 A	2	KN/110	2 x 160 A Size 00	38DR 2090 ⁽¹⁾⁽²⁾				3898 2160		
1100 A	4 (2 //)	DIN 43620 3	2 x 160 A Size 00	38DR 4110 ⁽¹⁾⁽²⁾	Red/Yellow IP65 1444 3111			3898 2150		
1600 A	4 (2 //)	KN/110	2 x 160 A Size 00	38DR 4160 ⁽¹⁾⁽²⁾				3898 2160		

(1) Coil must be ordered separately.

(2) Include standard fuse protection cover. If fuse microswitch is used please use specific fuse protection cover.

(3) Max 8 contacts (4 already provided with the switch).

(4) IP20 kit, please consult us.

(5) 2 pieces.

Characteristics according to IEC 60947-3

Products	125 A	160 A	250 A	400 A	630 A	900 A	1100 A	1600 A
Main poles size	00	1	2	3	3	3	3	3
No. of main poles	2	2	2	2	2	2	4 (2 //)	4 (2 //)
Fuse size of main poles	000 / 00	1	1 / 2	2 / 3	3	K / 110	3	K / 110
Main poles								
Thermal current I_{th} at 40°C (A)	125	160	250	400	630	900	1100	1600
Rated insulation voltage U _i (V)	1000	1000	1000	1250	1250	1250	1250	1250
Rated impulse withstand voltage U _{imp} (kV)	8	8	8	12	12	12	12	12
Load duty category	DC-20	DC-20	DC-20	DC-20	DC-20	DC-20	DC-20	DC-20
Fuse protected short-circuit withstand								
Current peak value: withstand and making (peak kA)	50	50	50	50	50	50	50	50
Prospective short-circuit current (kA rms) ⁽¹⁾	22.7	32.5	40	70	70	90	70	90
Heat dissipation								
Maximum fuse dissipation per pole (W)	7.7	15.3	29.3	56.9	70	108	70	108
Maximum switch dissipation per pole (W)	6.3	6.5	10.6	30	46	60	52	54
Pre-load poles								
Fuse size of pre-charge poles (DIN 43620)	00	00	00	00	00	00	00	00
Number of pre-charge poles	2	2	2	2	2	2	2	2
Thermal current I_{th} at 40°C (A)	160	160	160	160	160	160	160	160
Rated insulation voltage U _i (V) (operation circuit)	1000	1000	1000	1000	1000	1000	1000	1000
Rated impulse withstand voltage U _{imp} (kV) (operation circuit)	8	8	8	8	8	8	8	8
Fuse protected short-circuit withstand								
Current peak value: withstand and making (peak kA)	100	100	100	100	100	100	100	100
Prospective short-circuit current (kA rms) ⁽¹⁾	20	20	20	20	20	20	20	20
Heat dissipation								
Maximum fuse dissipation per pole (W)	12	12	12	12	12	12	12	12
Maximum switch dissipation per pole (W)	6.3	6.3	6.3	6.3	6.3	6.3	6.3	6.3
Mechanical characteristics								
Endurance (number of operating cycles) ⁽²⁾	1500	1500	1500	1500	1500	1500	1500	1500

(1) U_n = 400 VAC with gG fuses (AC value for information only).

(2) 300 max./hour.

Accessories

Coils kit

Use

Accessory required for the good functioning of the product.

Voltage	Reference
24 VDC	38DR C024
230 VAC	38DR A230



access_318

Specific protective covers for fitted fuse blown microswitch

Product	NFC/DIN fuse size	No. of poles	Reference
125 A	00	2	3990 7015
160 A	1	2	3990 7024
250 A	2	2	3990 7039
400 A	3	2	3890 7063
630 A	3	2	3890 7064
900 A	3	2	standard
1100 A	3	4 (2 //)	3890 9063
1600 A	3	4 (2 //)	standard



access_221

Solid links

Product	NFC/DIN fuse size	No. of poles	Reference
125 A	00	2	6420 0000
160 A	1	2	6421 0001
250 A	2	2	6421 0002
400 A	3	2	6421 0003
630 A	3	2	6421 0003
900 A	3	2	consult us
1100 A	3	4 (2 //)	6421 0003
1600 A	3	4 (2 //)	consult us



fusb_124

Operating diagram



Pre-load auxiliary contact
 54 - 53
 64 - 63



Auxiliary contact
 11 - 12
 21 - 22

MANUAL - Step 1

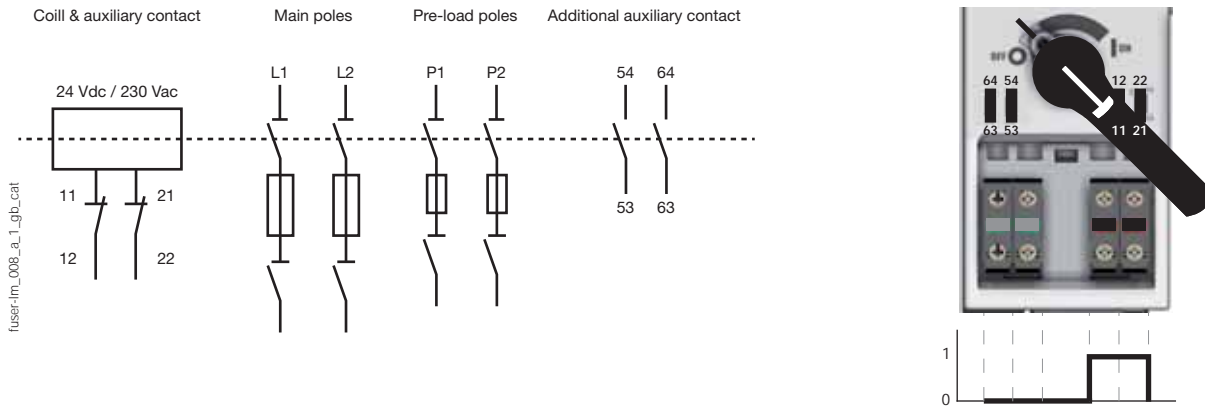

MANUAL - Step 2

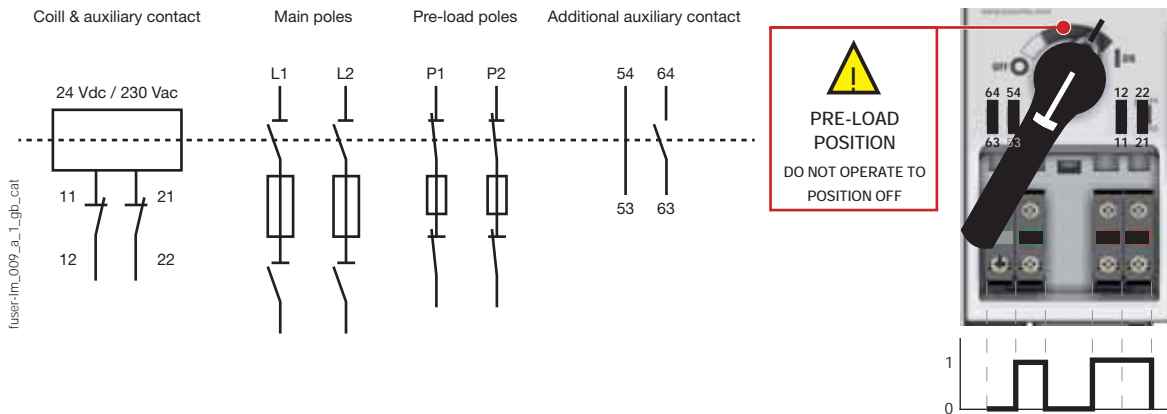

AUTO - Step 3

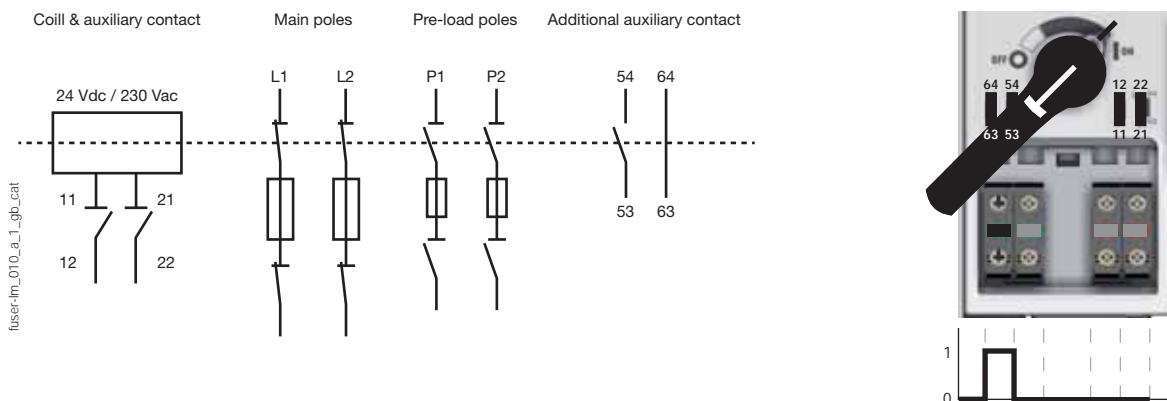

Operating diagram (continued)

Main poles and auxiliary contacts

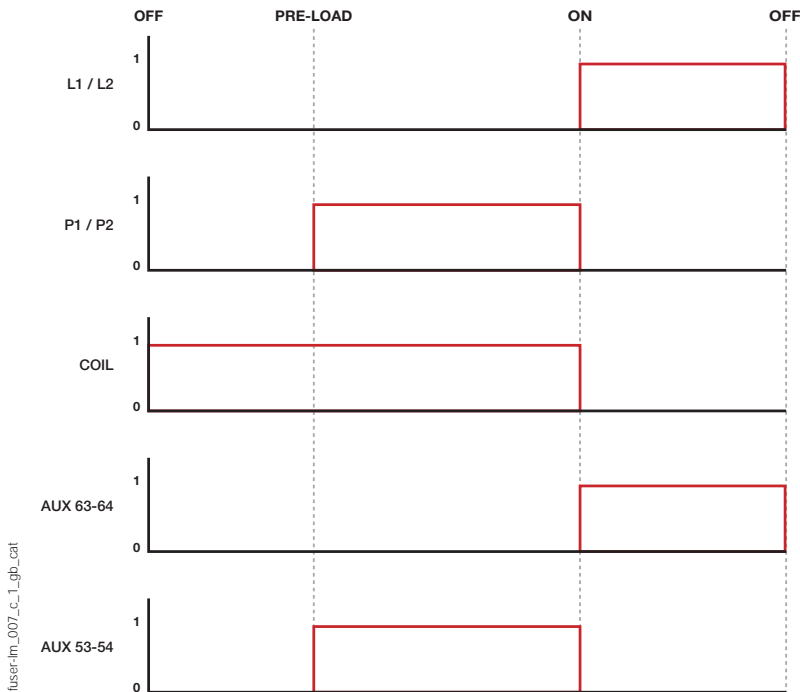

Dimensions

DC switches 125 to 250 A

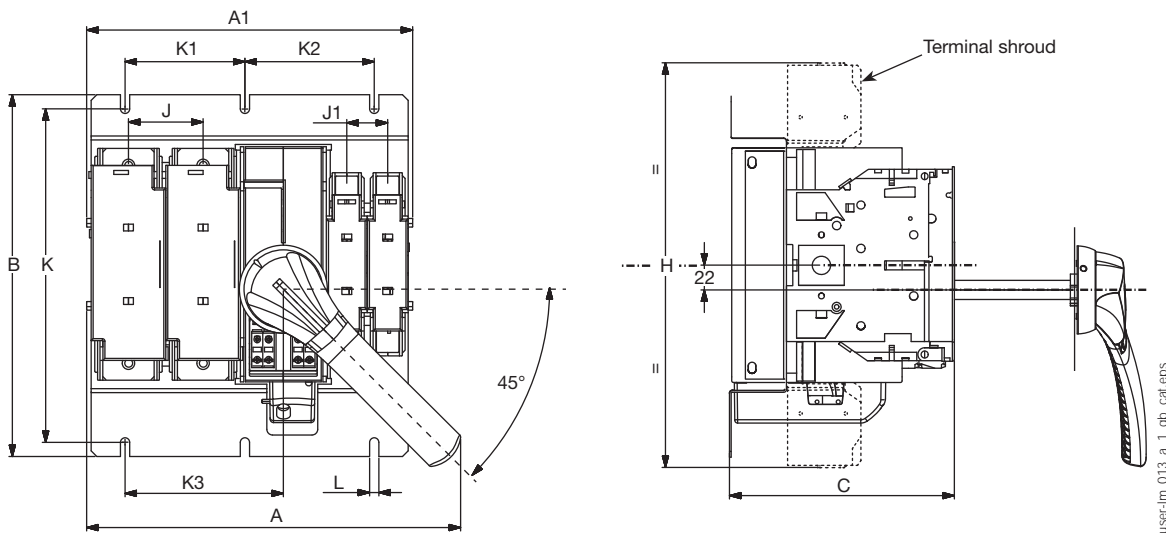

Rating (A)	Unit	A	A1	B	C	H	J	J1	K	K1	K2	K3	L
125	in	36	48	12.59	7	10.55	1.41	1.41	11.61	6.35	-	3.18	0.32
	mm	271	229	320	178	268	36	36	295	161.5	-	81	8.2
160	in	12.87	11.20	12.59	7.73	13.58	2.36	1.41	11.61	4.17	4.05	5.51	0.32
	mm	327	284.5	320	196.5	345	60	36	295	106	114.5	140	8.2
250	in	13.03	11.35	12.59	7.85	14.13	2.59	1.41	11.61	4.17	4.05	5.51	0.32
	mm	331	288.5	320	199.5	359	66	36	295	106	114.5	140	8.2

DC switches 400 to 1600 A

400 to 900 A

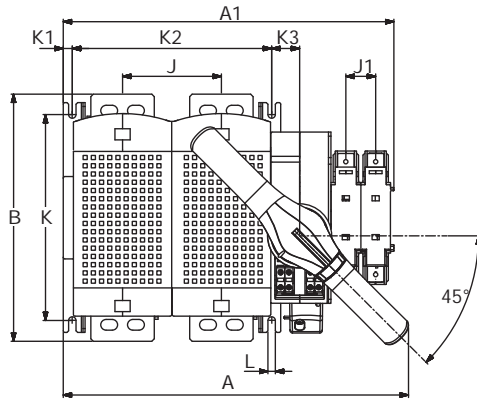

Connection terminals
 400 to 630 A

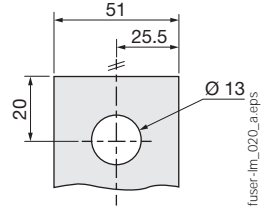

900 A

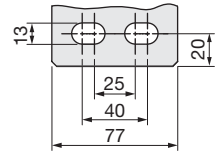

fuser-lm_021_a.eps

1100 to 1600 A

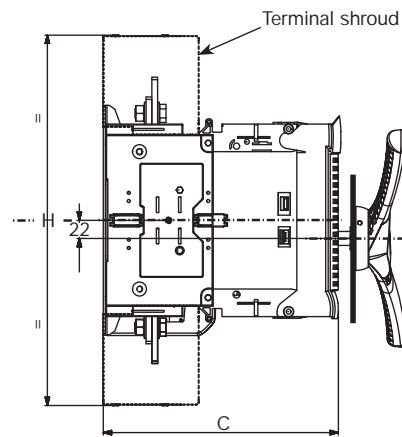
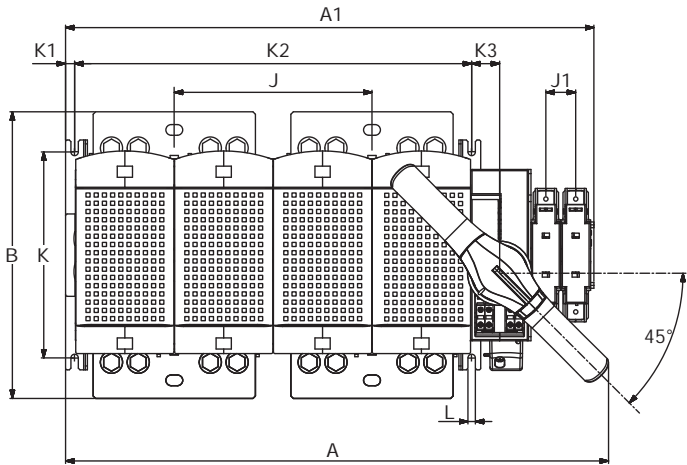

fuser-lm_014_a_1_gb_cat.eps

Rating (A)	Unit	A	A1	B	C	H	J	J1	K	K1	K2	K3	L
400 ... 630	in	14.44	13.75	11.81	9.84	18.54	3.70	1.41	9.84	0.43	7.48	1.33	0.35
	mm	367	349.5	300	250	471	94	36	250	11	190	34	9
900	in	16.49	15.80	11.81	11.25	17.73	4.72	1.41	9.84	0.43	9.52	1.33	0.35
	mm	419	401.5	300	286	450.5	120	36	250	11	242	34	9
1100	in	21.85	21.16	13.70	9.84	18.54	7.40	1.41	9.84	0.43	14.88	1.33	0.35
	mm	555	537.5	348	250	471	188	36	250	11	378	34	9
1600	in	25.94	25.25	13.70	11.25	17.73	9.44	1.41	9.84	0.43	18.97	1.33	0.35
	mm	659	641.5	348	286	450.5	240	36	250	11	482	34	9

RM and RMS

Fused disconnectors

for industrial and ultra-fast cylindrical fuses up to 125 A



The solution for

- > Small outputs

Strong points

- > Improved safety
- > High breaking capacity
- > Format and specific accessories
- > Label holder

Extended range

- > Lock cradle, please contact us

Compliance with standards

- > IEC 60269-2-1
- > IEC 60269-1
- > IEC 60269-2
- > NF EN 60269-1
- > NF C 63-210
- > NF C 63211
- > VDE 0636-10
- > DIN 43620
- > CSA 265615
- > UL E307648



Approvals and certifications⁽¹⁾



⁽¹⁾ Product part numbers on request.

Function

RM and **RMS** are modular fuse disconnect switches for cylindrical fuses. They provide safety disconnection and protection against overloads and short-circuits in any low voltage electrical circuit.

- RM: Non-signalling fuse disconnect switches for fuses without strikers.
- RMS: Fuse disconnect switches with pre-breaking auxiliary contact that signals that the fuse is present / blown.

Advantages

Improved safety

- Omnipolar and simultaneous breaking.
- High dielectric strength. IP2X fuse.

Format and specific accessories

- Modular 45-mm cut-out.
- Locking possible with optional accessory.

High breaking capacity

Protection against overloads and short-circuits thanks to high breaking capacity fuses (100 kA ms).

References

RM - Non-signalling device

Basic device Fuse size	32 A ⁽¹⁾ 10 x 38		50 A ⁽²⁾ 14 x 51		100 A ⁽²⁾ 22 x 58	
	Available for order in multiples of	Reference	Available for order in multiples of	Reference	Available for order in multiples of	Reference
No. of poles						
1 P	12	5701 0015	6	5702 5001	6	5703 5001
1 P + N (1 module)	12	5701 5005				
1 P + N (2 modules)	6	5701 0017	3	5702 5005		
1 P LED signalling			6	5702 0011	6	5703 0011
2 P	6	5701 0020	3	5702 5002	3	5703 5002
3 P	4	5701 0018	2	5702 5003	2	5703 5003
3 P + N	3	5701 0019	1	5702 5004	1	5703 5004
4 P			1	5702 5006	1	5703 5006
N	12	5701 0016	6	5702 5000	6	5703 5000

(1) Devices are cURus and CSA-certified, except 5701 5005.

(2) Devices are cURus-certified.

RMS - Device with 1 signalling auxiliary contact (AC) ⁽¹⁾

Basic device Fuse size	50 A ⁽²⁾ 14 x 51		100 A ⁽²⁾ 22 x 58	
	Available for order in multiples of	Reference	Available for order in multiples of	Reference
No. of poles				
1 P	6	5702 5011	6	5703 5011
2 P	3	5702 5012	3	5703 5012
3 P	2	5702 5013	2	5703 5013
3 P + N	1	5702 5014	1	5703 5014
4 P	1	5702 5016	1	5703 5016

(1) The signalling auxiliary contact provides the pre-break, the fuse presence and also signals a blown fuse.

(2) Devices are cURus-certified.

Something to think about



10x38 RMs equipped with 0.5A gG fuses provide effective protection for voltage inputs and auxiliary power supplies for all our electronic devices (DIRIS, COUNTIS, ISOM, RESYS differential relays, etc...)

RM and RMS

Fuse disconnect switches

for industrial and ultra-fast cylindrical fuses up to 125 A

Accessories

Auxiliary contact

Use

1 or 2 NO/NC auxiliary contacts:

- RMS 50 and 100: pre-breaking, fuse is present / blown.
- RM 50 and 100: fuse blown.

Connection

By 6.35 mm fast-on terminal.

Characteristics		Operating current I_e (A)
Rating (A)	Contact type	
50 ... 100	NO/NC contact	2.5
50 ... 100	Two-level NO/NC contact	0.1

References		
NO/NC contact Rating (A)	Contact	Reference
50	1 auxiliary contact with 1 P	5702 9901
50	1 auxiliary contact with 3 P	5702 9903
50	2 auxiliary contacts with 3 P	5702 9030
100	1 auxiliary contact with 1 P	5703 9901
100	1 auxiliary contact with 3 P	5703 9903
100	2 auxiliary contacts with 3 P	5703 9030

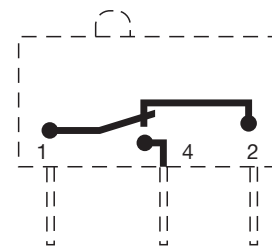
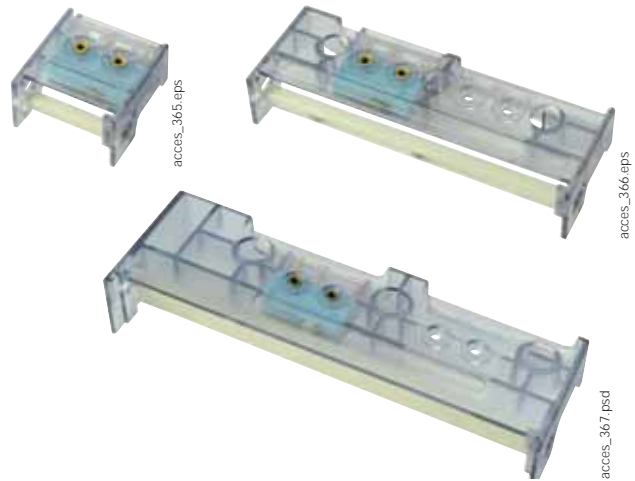

access_068_a_1_x_cat

RM and RMS

Fuse disconnect switches

for industrial and ultra-fast cylindrical fuses up to 125 A

Key handle interlocking system

Use

Padlocking of the handle (padlock not supplied).

For RM and RMS		
Rating (A)	Quantity (units)	Reference
50	5	5702 9040

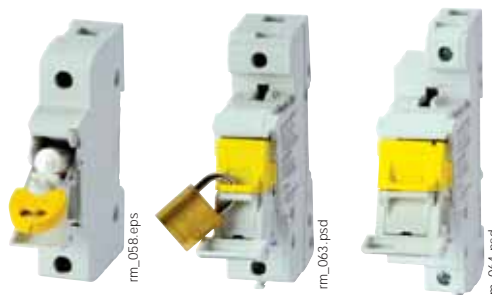

Coupling system for RM

For RM and RMS		
Rating (A)	Quantity (units)	Reference
32	12	5704 0003 ⁽¹⁾
50 ... 100	12	5702 9020 ⁽¹⁾

⁽¹⁾ One coupling to attach two RM/RMS.
Also sold in bags containing separate components
(bags of 100 pieces) for assembling larger quantities.
Contact us

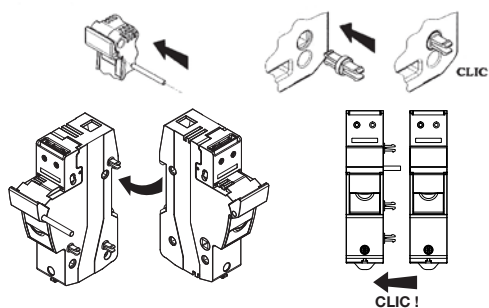

RM and RMS

Fuse disconnect switches

for industrial and ultra-fast cylindrical fuses up to 125 A

Characteristics according to IEC 60269-2

32 to 100 A

Thermal current I_{th} (20 °C)	32 A	50 A	100 A
Fuse size	10 x 38	14 x 51	22 x 58
Rated insulation voltage U_i (V)	690	690	690
Nominal power loss (W/P)	3	5	9.5 (max 12 W)
Protection degree	IP20	IP20	IP20
Fuse rating (A)			
at 400 VAC	32	50	125
at 500 VAC	32	50	125
at 690 VAC		50	125
gG fuse protected short-circuit withstand			
	Rated voltage		
Prospective short-circuit current (kA rms)	690 VAC	100	100
Prospective short-circuit current (kA rms)	400/500 VAC	120	120
Derating factor of operational current for N poles side by side			
N = 1 ... 3	1	1	1
N = 4 ... 6	0.8	0.8	0.8
N = 7 ... 9	0.7	0.7	0.7
N ≥ 10	0.6	0.6	0.6
Derating factor of operational current for N poles side by side			
20 °C	1	1	1
30 °C	0.95	0.95	0.95
40 °C	0.90	0.90	0.90
50 °C	0.80	0.80	0.80
60 °C	0.70	0.70	0.70
70 °C	0.60	0.60	0.60
Connection			
Min. cross-section of rigid/flexible Cu cables	0.75 mm ²	1.5 mm ²	1.5 mm ²
Max. cross-section of rigid Cu cables	16 mm ²	35 mm ²	50 mm ²
Max. cross-section of rigid Cu cables for RM32 1 P + N (1 module)	10 mm ²		
Max. cross-section of flexible Cu cables	16 mm ²	25 mm ²	35 mm ²
Max. cross-section of flexible Cu cables for RM32 1 P + N (1 module)	6 mm ²		
Clamping torque	2.5 Nm	3 Nm	4 Nm
Tightening torque for RM32 1 P + N (1 module)	2 Nm		
Dimensional data			
Weight of 1 P + N (kg)	0.057 / 0.06	0.1	0.155
Weight of 1 P + N (kg)	0.117	0.215	0.327
Weight of 3 P + N (kg)	0.229	0.415	0.632

Dimensions (in/mm)

RM 32 A

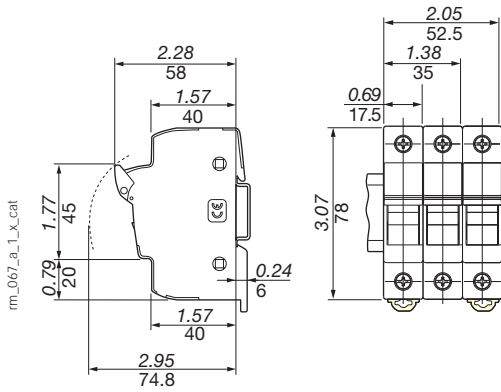

RM / RMS 50 A single-pole and multi-pole

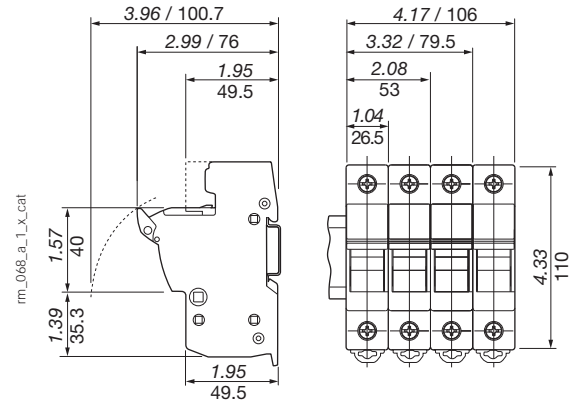

RM / RMS 100 A single-pole and multi-pole

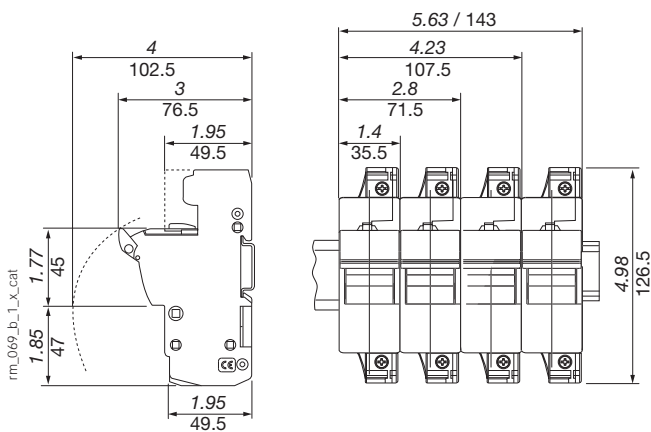

RM 32 A Part no. 5701 5005

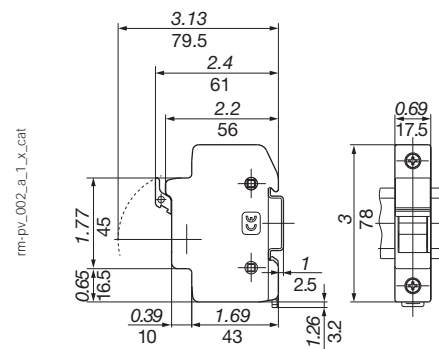

Fuse bases

Fuse protection

for NH industrial and high-speed (uR) fuses from 160 to 2500 A

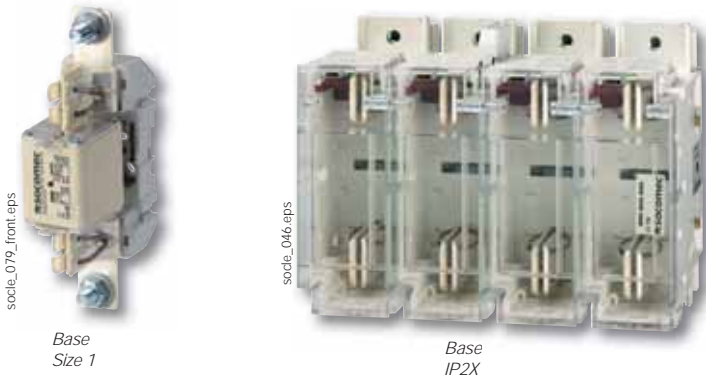

Function

SOCOMEC **fuse bases** are unipolar or multipolar supports for knife-edge fuses.

Advantages

High level of electrical safety

- High dielectric strength.
- IP2X protection (standard or optional depending on models).

High breaking capacity

Protection against overloads and short-circuits thanks to high breaking capacity fuses

(100 kA rms).

Fuse blown indicator

When used with striker fuses, the fuse blown indication is possible thanks to an auxiliary contact.

Various mounting options

DIN rail or back plate mounting (depending on models).

The solution for

- > Motor feeders
- > Protection of industrial cabinet



Strong points

- > High level of electrical safety
- > Fuse blown indicator
- > Various mounting options

Compliance with standards

- > IEC 60269-1
- > IEC 60269-2
- > IEC 60269-2,-1
- > NF EN 60269-1
- > NF C 63211
- > VDE 0636-10
- > DIN 43620



Functional diagram

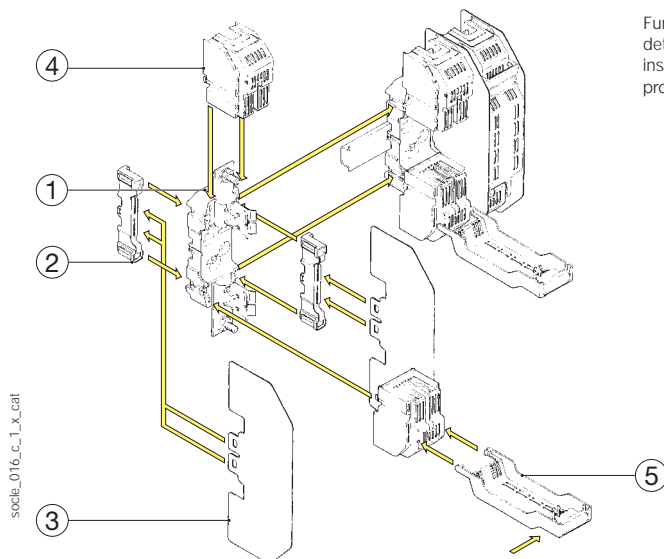

Functional diagram (for further details see the installation instructions supplied with the product)

1. Fuse bases
2. Connecting block:
 - block for assembling unipolar bases T00, T0, T1, T2 and T3
 - support for interphase barriers T00, T0, T1, T2 and T3
3. Phase separation shield
4. Terminal shrouds (necessary for mounting fuse covers)
5. Fuse cover (provides IP2 protection for any brand of fuse)

- IP20 Kit:
- unipolar = 2 connecting blocks + 2 phase separation shields + 2 terminal shrouds + 1 fuse cover
 - tripolar = 2 connecting blocks (for the ends) + 2 phase separation shields for the ends + 6 terminal shrouds + 3 fuse covers.

References

Fuse bases for fuses without a striker from 160 to 630 A (U = 690 V)

Rating Fuse size		160 A 00	160 A 0	250 A 1	400 A 2	630 A 3
Back plate mounted device						
No. of poles	To be ordered in multiples of	Reference	Reference	Reference	Reference	Reference
1 P	3	6500 1010	6501 1010	6501 1011	6501 1012	6501 1013
3 P	1	6500 1030	6501 1030	6501 1031	6501 1032	6501 1033
DIN rail-mounted device						
No. of poles	To be ordered in multiples of	Reference	Reference	Reference	Reference	Reference
1 P	3	6500 1110	6501 1110	6501 1111	6501 1112	6501 1113
3 P	1	6500 1130	6501 1130	6501 1131	6501 1132	6501 1133
Options: IP20 kit						
No. of poles		Reference	Reference	Reference	Reference	Reference
1 P ⁽¹⁾		6510 1010	6511 1010	6511 1011	6511 1012	6511 1013
3 P ⁽²⁾		6510 1030	6511 1030	6511 1031	6511 1032	6511 1033
Accessories						
Description of accessories	To be ordered in multiples of	Reference	Reference	Reference	Reference	Reference
Connecting block - set of 1 piece	2	6500 0033	6500 0030	6500 0031	6500 0031	6500 0032
Phase separation shield - set of 1 piece	2	6500 0001	6500 0002	6500 0003	6500 0003	6500 0004
Terminal shrouds - set of 1 piece	6	6500 0010	6500 0011	6500 0012	6500 0013	6500 0014
Fuse cover - set of 1 piece	3	6500 0020	6500 0021	6500 0022	6500 0022	6500 0023

(1) IP20 unipolar kit comprises - 2 connecting blocks, 2 phase separation shields, 2 terminal shrouds and 1 fuse cover.

(2) IP20 tripolar kit comprises - 2 connecting blocks for the ends, 2 phase separation shields for the ends, 6 terminal shrouds and 3 fuse covers.

Dimensions

160 A fuse base, size 00

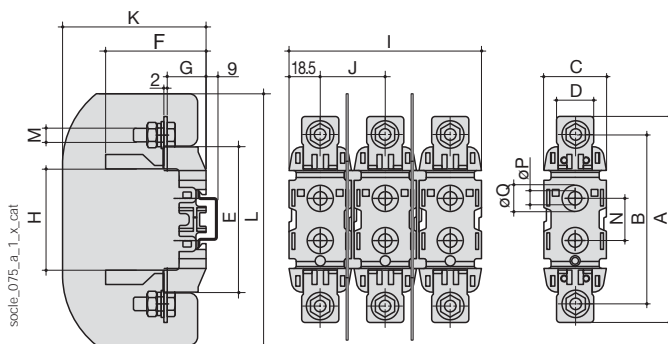

160 to 630 A fuse base, sizes 0, 1, 2 and 3

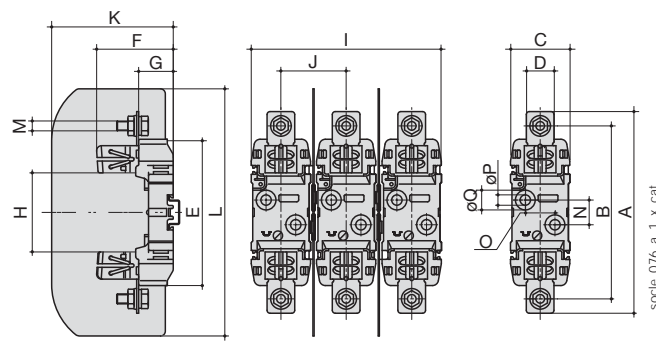

Rating (A)	Fuse size	A	B	C	D	E	F	G	H	I	J	K	L	M	N	O	P	Q
160	00	122	100	37	22	86	59.5	23	57	114	38.5	85	146	M8	25	-	8	15
160	0	170	150	47	24	122	63	29	74	144	48.5	91.5	185	8	25	-	7.5	15
250	1	200	175	60	28	148	77.5	35	80	192	66	123	250	10	25	30	10.5	20.5
400	2	225	200	60	32	148	88	35	80	192	66	123	250	12	25	30	10.5	20.5
630	3	240	210	60	38	148	97	35	80	224	82	143	270	12	25	30	10.5	20.5

Fuse bases

Fuse protection

for NH industrial and high-speed (uR) fuses from 160 to 2500 A

References

Unipolar fuse bases for fuses with a striker from 160 to 630 A (U = 690 V)

Rating Fuse size	160 A 0	250 A 1	400 A 2	630 A 3
Back plate mounted device without AC				
No. of poles	Reference	Reference	Reference	Reference
1 P	6501 1010	6501 1011	6501 1012	6501 1013
DIN rail-mounted device without AC				
No. of poles	Reference	Reference	Reference	Reference
1 P	6501 1110	6501 1111	6501 1112	6501 1113
Accessories				
Presence and fuse blown signalling AC (DDMM)				
No. of poles	Reference	Reference	Reference	Reference
1 P	6500 0040	6500 0041	6500 0042	6500 0043
Characteristics				
NO/NC contact				
Nominal current I _n (A) 250 VAC	16	16	16	16

Dimensions

160 to 630 A fuse base, sizes 0, 1, 2 and 3

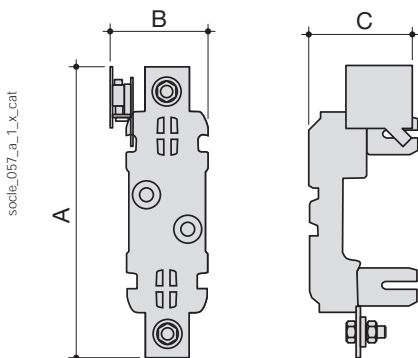

Rating (A)	Fuse size	A	B	C
160	0	193	65.5	90
250	1	215	76	98
400	2	227	76	102
630	3	235	76	102

References

Multipolar fuse bases for fuses with a striker from 160 to 400 A (U = 690 V)

Rating Fuse size	160 A 0	250 A 1	400 A 2
Back plate mounted device with presence and fuse blown signalling AC (DDMM)			
No. of poles	Reference	Reference	Reference
2 P	6301 2016	6301 2024	6301 2039
3 P	6301 3016	6301 3024	6301 3039
4 P	6301 4016	6301 4024	6301 4039
Auxiliary contacts for fuse blown indication			
AC position	Reference	Reference	Reference
1 st AC	included	included	included
2 nd	3994 1901	3994 1901	3994 1901
Terminal shrouds (1 piece)			
No. of poles	Reference	Reference	Reference
2 P	3998 2016	3998 2025	3998 2025
3 P	3998 3016	3998 3025	3998 3025
4 P	3998 4016	3998 4025	3998 4025

Dimensions

160 to 400 A fuse base, size 0

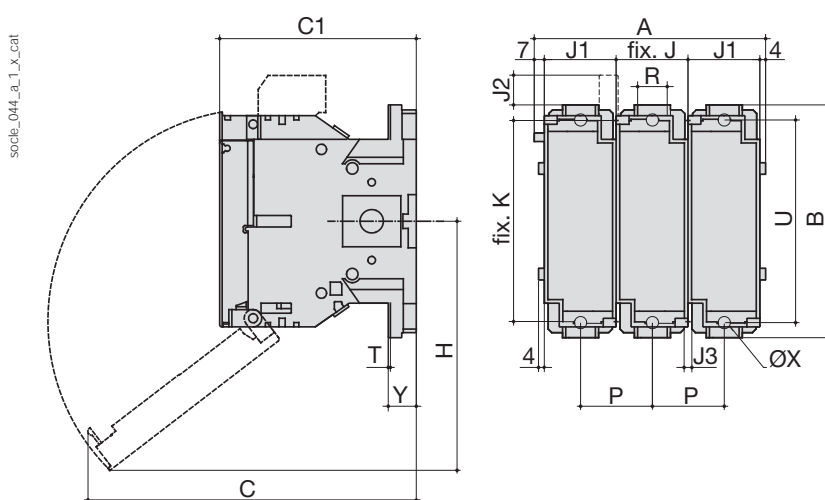

Rating (A)	Fuse size	A 2 p.	A 3 p.	A 4 p.	B	C	C1	H	J	J1	J2	J3	K	P	R	T	U	ØX	Y
160	0	111	161	211	162	229	136.5	174	50	60	20.5	5.4	140	50	20	2.5	141	8.5	19.5
250	1	131	191	251	195	251	146	185	60	60	7.5	6.4	162	60	32	2.5	166	11	19.5
400	2	143	209	275	205	260	149	200	66	66	2.5	6.4	172	66	50	3	175	11	20

Fuse bases

Fuse protection

for NH industrial and high-speed (uR) fuses from 160 to 2500 A

References

Fuse bases for fuses with or without a striker from 1000 to 2500 A (U = 690 V)

Rating (A) Fuse size	1 000 A 4	1 250 A 4	2500 A 2 x 4	2 500 A 2 x 4 (S)	2 500 A 6 (for neutral)
Device without presence and fuse blown signalling (DDMM)					
No. of poles	Reference	Reference	Reference	Reference	Reference
1 P	6431 0004	6431 0005	6431 0006		6431 0007 ⁽¹⁾
Device with presence and fuse blown signalling (DDMM)					
No. of poles	Reference	Reference	Reference	Reference	Reference
1 P	7304 0001	7305 0001	7306 0001	6433 0005	

(1) Without solid neutral link.

Dimensions

1000 to 1250 A fuse base, size 4

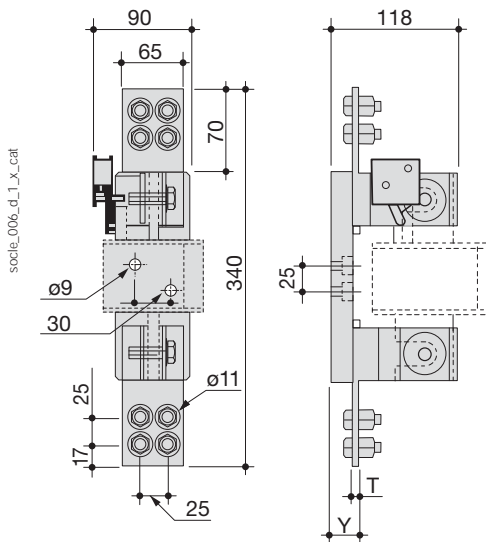

Rating (A)	Y (mm)	T (mm)
1000	25	4
1250	30	9

2500 A fuse base, size 2 X 4

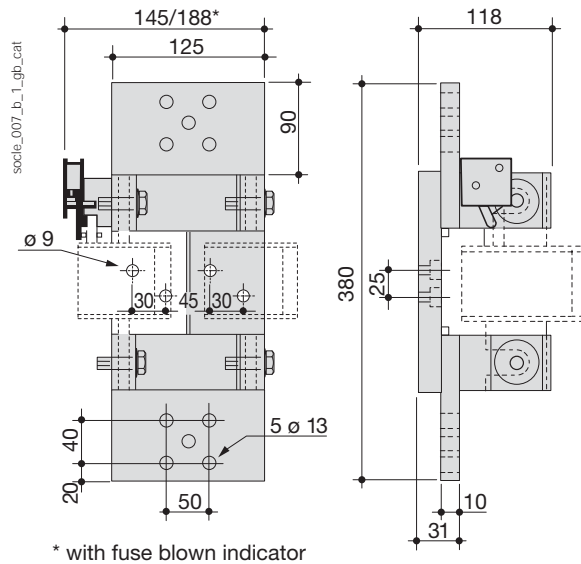

2500 A fuse base, 2 x 4 (S)

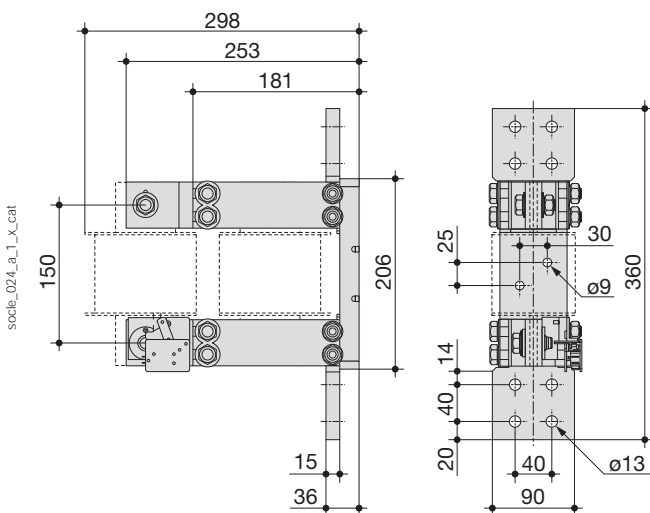

2500 A fuse base, size 6 (for neutral)

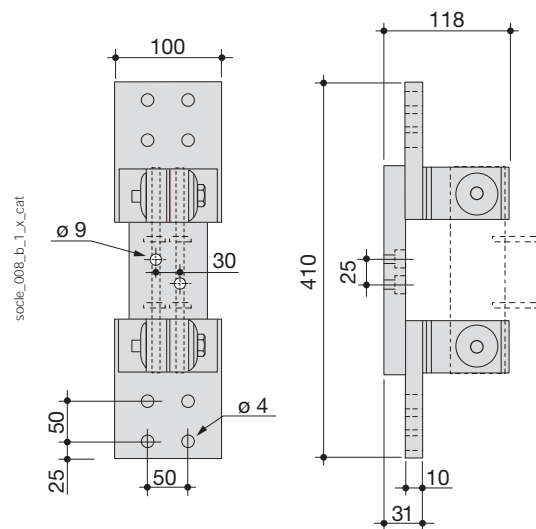

References

Unipolar fuse bases for UR fuses

	1000 VAC	1400 VAC	
L shaped bracket /80 (distance between centres 80)			
Thermal current I_{th} at 40°C	Type of fuse	Reference	Reference
400	0000 ... 00 bolted connection	170H 1007	
Knife-edge fuses /80 (distance between centres 80)			
Thermal current I_{th} at 40°C	Type of fuse	Reference	Reference
1250 ⁽¹⁾	1* ... 3	170H 3004	
Knife-edge fuses /110 (distance between centres 110)			
Thermal current I_{th} at 40°C	Type of fuse	Reference	Reference
1250 ⁽¹⁾	1* ... 3	170H 3006	

(1) For currents > 1250 A, please consult us.

Dimensions

Bracket /80 - 400 A - 1000 VAC
Ref.: 170H 1007

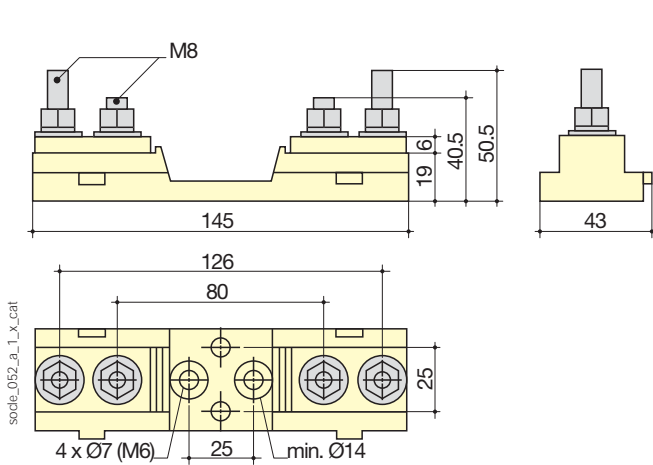

Knife-edge /80 - 1250 A - 1000 VAC
Ref.: 170H 3004

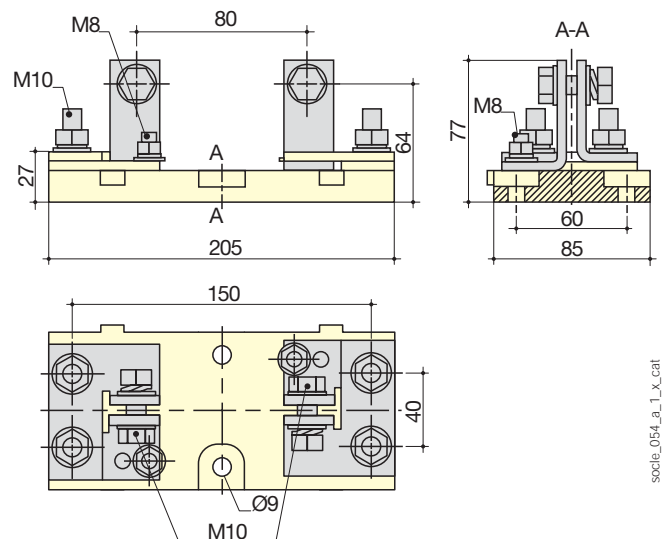

Knife-edge /110 - 1250 A - 1400 VAC - Ref: 170H 3006

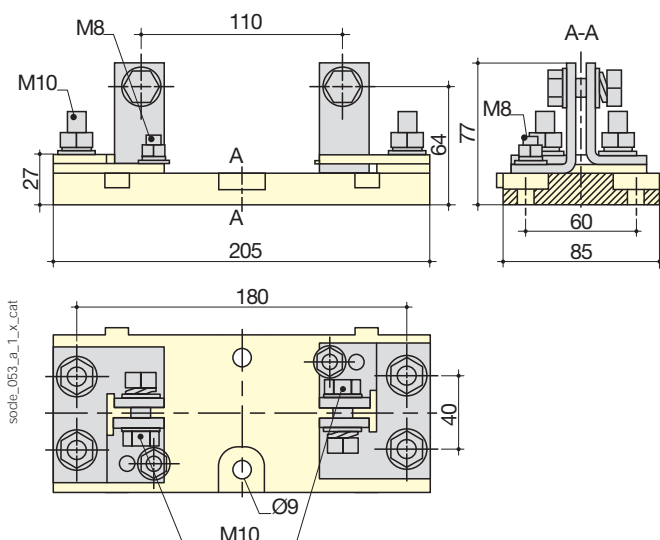

Industrial fuses

NFC-DIN industrial fuselinks gG and aM curves
from 0.5 to 1250 A



gG type fuse, 14 x 51
from 1 to 50 A



aM type fuse, NH000
from 6 to 100 A



gG type fuse, NH0,
with striker
from 16 to 200 A



gG type fuse, NH2
from 100 to 500 A



aM type fuse, NH4
from 315 to 1250 A

The solution for

- > Motor protection
- > Cable and device protection



Strong points

- > High level performances
- > High reliability
- > Improved safety

Conformity to standards

- > IEC 60269-1
- > DIN EN 60269-1
- > NF EN 60269-1
- > IEC 60269-2
- > NF EN 60269-2



Function

SOCOMEK industrial fuses protect installations and people from overcurrents for any low voltage electrical circuit.

Advantages

High level performances

- High breaking capacity - 120 kA at 400/500 V, 80 kA at 690 V.
- High short-circuit limitation capacity.
- Simple and reliable discrimination.
- NH (size 000 to 3) type gG fuse links without striker : 250 VDC, 80 kA, L/R 20ms

High reliability

- Absolute protection over time guaranteed by the simplicity of manufacture and function (Joule effect).
- No downgrading of fuse characteristics over time.

Improved safety

The energy released whilst eliminating the fault (fuse blowing) is contained within the cartridge (no degassing).

References

gG type fuses (in multiples of 10)

Rating (A)	10 x 38 without striker		14 x 51 without striker		14 x 51 with striker		22 x 58 without striker		22 x 58 with striker	
	Voltage (VAC)	Reference	Voltage (VAC)	Reference	Voltage (VAC)	Reference	Voltage (VAC)	Reference	Voltage (VAC)	Reference
0.5	500	6012 0000								
1	500	6012 0001								
2	500	6012 0002			500	6052 0002				
4	500	6012 0004			500	6052 0004				
6	500	6012 0006			500	6052 0006				
8	500	6012 0008			500	6052 0008				
10	500	6012 0010			500	6052 0010				
12	500	6012 0012			500	6052 0012				
16	500	6012 0016	690	6022 0016	500	6052 0016			690	6062 0020
20	500	6012 0020	690	6022 0020	500	6052 0020			690	6062 0020
25	500	6012 0025	690	6022 0025	500	6052 0025			690	6062 0025
32	400	6012 0032	500	6022 0032	500	6052 0032	690	6032 0032	690	6062 0032
40			500	6022 0040	500	6052 0040	690	6032 0040	690	6062 0040
50			400	6022 0050	400	6052 0050	690	6032 0050	690	6062 0050
63							690	6032 0063	690	6062 0063
80							500	6032 0080	500	6062 0080
100							500	6032 0100	500	6062 0100
125							400	6032 0125	400	6062 0125

Description of accessories

Solid cylindrical link	Reference 6019 0000		Reference 6029 0000		Reference 6029 0000		Reference 6039 0000		Reference 6039 0000
------------------------	------------------------	--	------------------------	--	------------------------	--	------------------------	--	------------------------

aM type fuses (in multiples of 10)

Rating (A)	10 x 38 without striker		14 x 51 without striker		14 x 51 with striker		22 x 58 without striker		22 x 58 with striker	
	Voltage (VAC)	Reference	Voltage (VAC)	Reference	Voltage (VAC)	Reference	Voltage (VAC)	Reference	Voltage (VAC)	Reference
0.5	500	6013 0000								
1	500	6013 0001								
2	500				500	6053 0002				
4	500	6013 0004			500	6053 0004				
6	500				500	6053 0006				
8	500	6013 0008			500	6053 0008				
10	500	6013 0010			500	6053 0010				
12					500	6053 0012				
16	500	6013 0016	690	6023 0016	500	6053 0016				
20	400	6013 0020			500	6053 0020				
25	400	6013 0025	690	6023 0025	500	6053 0025			690	6063 0025
32			500	6023 0032	500	6053 0032			690	6063 0032
40			500	6023 0040	500	6053 0040	690	6033 0040	690	6063 0040
50			400	6023 0050	400	6053 0050	690	6033 0050	690	6063 0050
63							690	6033 0063	690	6063 0063
80							500	6033 0080	500	6063 0080
100							500	6033 0100	400	6063 0100
125							400	6033 0125	400	6063 0125

Description of accessories

Solid cylindrical link	Reference 6019 0000		Reference 6029 0000		Reference 6029 0000		Reference 6039 0000		Reference 6039 0000
------------------------	------------------------	--	------------------------	--	------------------------	--	------------------------	--	------------------------

Industrial fuses

NFC-DIN industrial fuselinks gG and aM curves

from 0.5 to 1250 A

References (continued)

Knife-edge fuses (NH), gG type

Rating (A)	000/00C without striker (in multiples of 3)		00 without striker (in multiples of 3)		0 without striker (in multiples of 3)		0 with striker (in multiples of 3)		1 without striker (in multiples of 3)		1 with striker (in multiples of 3)	
	Voltage (VAC)	Reference	Voltage (VAC)	Reference	Voltage (VAC)	Reference	Voltage (VAC)	Reference	Voltage (VAC)	Reference	Voltage (VAC)	Reference
6	500	6600 0006										
10	500	6600 0010										
16	500	6600 0016										
20	500	6600 0020										
25	500	6600 0025										
32	500	6600 0032										
40	500	6600 0040					690	6852 0040				
50	500	6600 0050					690	6852 0050				
63	500	6600 0063			500	6702 0063	690	6852 0063	500	6712 0063		
80	500	6600 0080			500	6702 0080	690	6852 0080	500	6712 0080		
100	500	6600 0100			500	6702 0100	690	6852 0100	500	6712 0100	690	6862 0100
125			500	6692 0125	500	6702 0125	500	6852 0125	500	6712 0125	690	6862 0125
160			500	6692 0160	500	6702 0160	500	6852 0160	500	6712 0160	690	6862 0160
200									500	6712 0200	690	6862 0200
250									500	6712 0250	500	6862 0250
315									400	6712 0315	500	6862 0315

Description of accessories

	Reference		Reference		Reference		Reference		Reference		Reference
Neutral bar	6420 0000		6420 0000		6421 0000		6421 0000		6421 0001		6421 0001

Rating (A)	2 without striker (in multiples of 3)		2 with striker (in multiples of 3)		3 without striker (to this unit)		3 with striker (to this unit)		4 without striker (to this unit)		4 with striker (to this unit)	
	Voltage (VAC)	Reference	Voltage (VAC)	Reference	Voltage (VAC)	Reference	Voltage (VAC)	Reference	Voltage (VAC)	Reference	Voltage (VAC)	Reference
100	500	6722 0100										
125	500	6722 0125										
160	500	6722 0160	690	6872 0160								
200	500	6722 0200	690	6872 0200								
250	500	6722 0250	690	6872 0250								
315	500	6722 0315	690	6872 0315	500	6732 0315						
400	500	6722 0400	500	6872 0400	500	6732 0400	690	6882 0400	500	6746 0400		
500	500	6722 0500	500	6872 0500	500	6732 0500	690	6882 0500	500	6746 0500		
630					500	6732 0630	500	6882 0630	500	6746 0630	500	6896 0630
800					500	6732 0800			500	6746 0800	500	6896 0800
900									500	6746 0900	500	6896 0900
1000									500	6746 1000	500	6896 1000
1250									500	6746 1200	500	6896 1200

Description of accessories

	Reference		Reference		Reference		Reference		Reference		Reference
Neutral bar	6421 0002		6421 0002		6421 0003		6421 0003		6441 0005		6441 0005

Knife-edge fuses (NH), aM type

Rating (A)	000/00C without striker (in multiples of 3)		00 without striker (in multiples of 3)		0 without striker (in multiples of 3)		0 with striker (in multiples of 3)		1 without striker (in multiples of 3)		1 with striker (in multiples of 3)	
	Voltage (VAC)	Reference	Voltage (VAC)	Reference	Voltage (VAC)	Reference	Voltage (VAC)	Reference	Voltage (VAC)	Reference	Voltage (VAC)	Reference
6	500	6601 0006										
10	500	6601 0010										
16	500	6601 0016										
20	500	6601 0020										
25	500	6601 0025										
32	500	6601 0032										
40	500	6601 0040										
50	500	6601 0050			500	6703 0050						
63	500	6601 0063			500	6703 0063	690	6853 0063				
80	500	6601 0080			500	6703 0080	690	6853 0080				
100			500	6693 0100	500	6703 0100	690	6853 0100	500	6713 0100	690	6863 0100
125			500	6693 0125	500	6703 0125	690	6853 0125	500	6713 0125	690	6863 0125
160			500	6693 0160	500	6703 0160	690	6853 0160	500	6713 0160	690	6863 0160
200					500	6703 0200	500	6853 0200	500	6713 0200	690	6863 0200
250									500	6713 0250	690	6863 0250
315									500	6713 0315	500	6863 0315

Description of accessories

	Reference		Reference		Reference		Reference		Reference		Reference
Neutral bar	6420 0000		6420 0000		6421 0000		6421 0000		6421 0001		6421 0001

Rating (A)	2 without striker (in multiples of 3)		2 with striker (in multiples of 3)		3 without striker (to this unit)		3 with striker (to this unit)		4 without striker (to this unit)		4 with striker (to this unit)	
	Voltage (VAC)	Reference	Voltage (VAC)	Reference	Voltage (VAC)	Reference	Voltage (VAC)	Reference	Voltage (VAC)	Reference	Voltage (VAC)	Reference
160	500	6723 0160	690	6873 0160								
200	500	6723 0200	690	6873 0200								
250	500	6723 0250	690	6873 0250								
315	500	6723 0315	690	6873 0315	500	6733 0315	690	6883 0315				
400	500	6723 0400	690	6873 0400	500	6733 0400	690	6883 0400				
500	500	6723 0500	500	6873 0500	500	6733 0500	690	6883 0500				
630					500	6733 0630	500	6883 0630	500	6747 0630	500	6897 0630
800									500	6747 0800	500	6897 0800
1000											500	6897 1000
1250											500	6897 1200

Description of accessories

	Reference		Reference		Reference		Reference		Reference		Reference
Neutral bar	6421 0002		6421 0002		6421 0003		6421 0003		6441 0005		6441 0005

Industrial fuses

NFC-DIN industrial fuselinks gG and aM curves
from 0.5 to 1250 A

Accessories

Solid cylindrical link

Use

Solid link to be used in conjunction with the neutral pole of cylindrical fused disconnecting switches.

3 sizes: 10 x 38, 14 x 51, 22 x 58.

Rating (A)	Size	To be ordered in multiples of	Reference
32	10 x 38	10	6019 0000
50	14 x 51	10	6029 0000
100	22 x 58	10	6039 0000



fusib_123

Solid links

Use

Solid link to be used in conjunction with fuse bases or knife-edge fused disconnecting switches, generally fitted on the neutral pole.

6 sizes: 000/00C/00-0-1-2-3-4.

Rating (A)	Size	Tightening	Reference
160	000/00C/00	elastic	6420 0000
160	0	elastic	6421 0000
315	1	elastic	6421 0001
400	2	elastic	6421 0002
630	3	elastic	6421 0003
1250	4	blocked	6441 0005

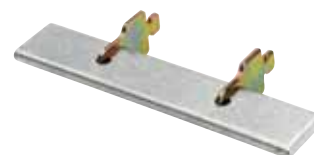

fusib_124

Fuse extraction tool

Use

For inserting and extracting knife-edge fuses, sizes 000 to 4.

Type	Reference
Fuse extraction tool	6401 0011



fusib_122

Dimensions

Cylindrical fuses (NF)

Without striker - with striker

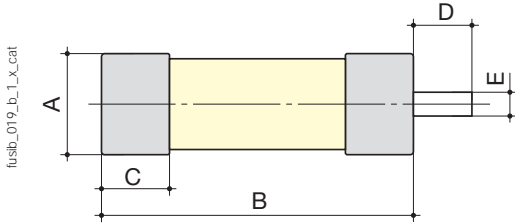

Standard dimensions (mm) as per IEC 60269-2-1

Size	A	B	C	D	E
10 x 38	10.3	38	10.5		
14 x 51	14.3	51	13.8	7.5	3.8
22 x 58	22.2	58	16.2	7.5	3.8

Knife-edge fuses (NH)

without striker

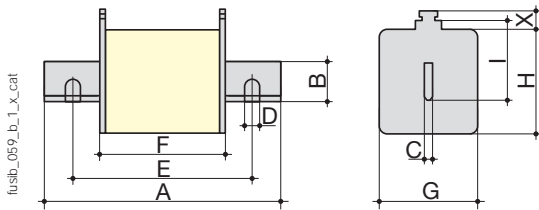

Standard dimensions (mm) as per IEC 60269-2-1

Size	A maxi	B mini	C	D	E mini	F maxi	G maxi	H maxi	I	X mini
000/00C	80	15	6			54	21	41	35	11
00	80	15	6			54	30	48	35	11
0	127.5	15	6			68	40	48	35	11
1	137.5	20	6			75	52	53	40	11
2	152.5	25	6			75	60	61	48	11
3	152.5	32	6			75	75	76	60	11
4	203	49	8	16	150	90	105	110	87	11

With striker

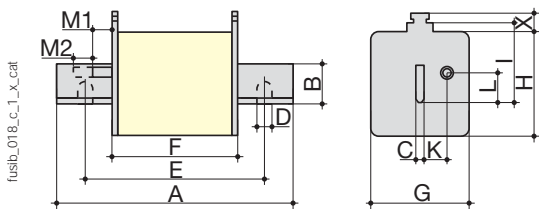

Standard dimensions (mm) as per IEC 60269-2-1

Size	A maxi	B mini	C	D	E	F maxi	G maxi	H maxi	I	K	L	M1	M2 mini	X mini
0	127.5	15	6			68	39	47	35	11.5	14	25	13	11
1	137.5	20	6			75	52	53	40	13	14.5	25.5	13	11
2	152.5	25	6			75	60	61	48	16	14.5	25.5	13	11
3	152.5	32	6			75	75	76	60	21	14.5	25.5	13	11
4	203	49	8	16	150	90	105	110	87	24.5	14.5	35	13	11

Industrial fuses

NFC-DIN industrial fuselinks gG and aM curves
from 0.5 to 1250 A

Curves characteristic of NF and NH gG type fuses

Cut-off current diagram

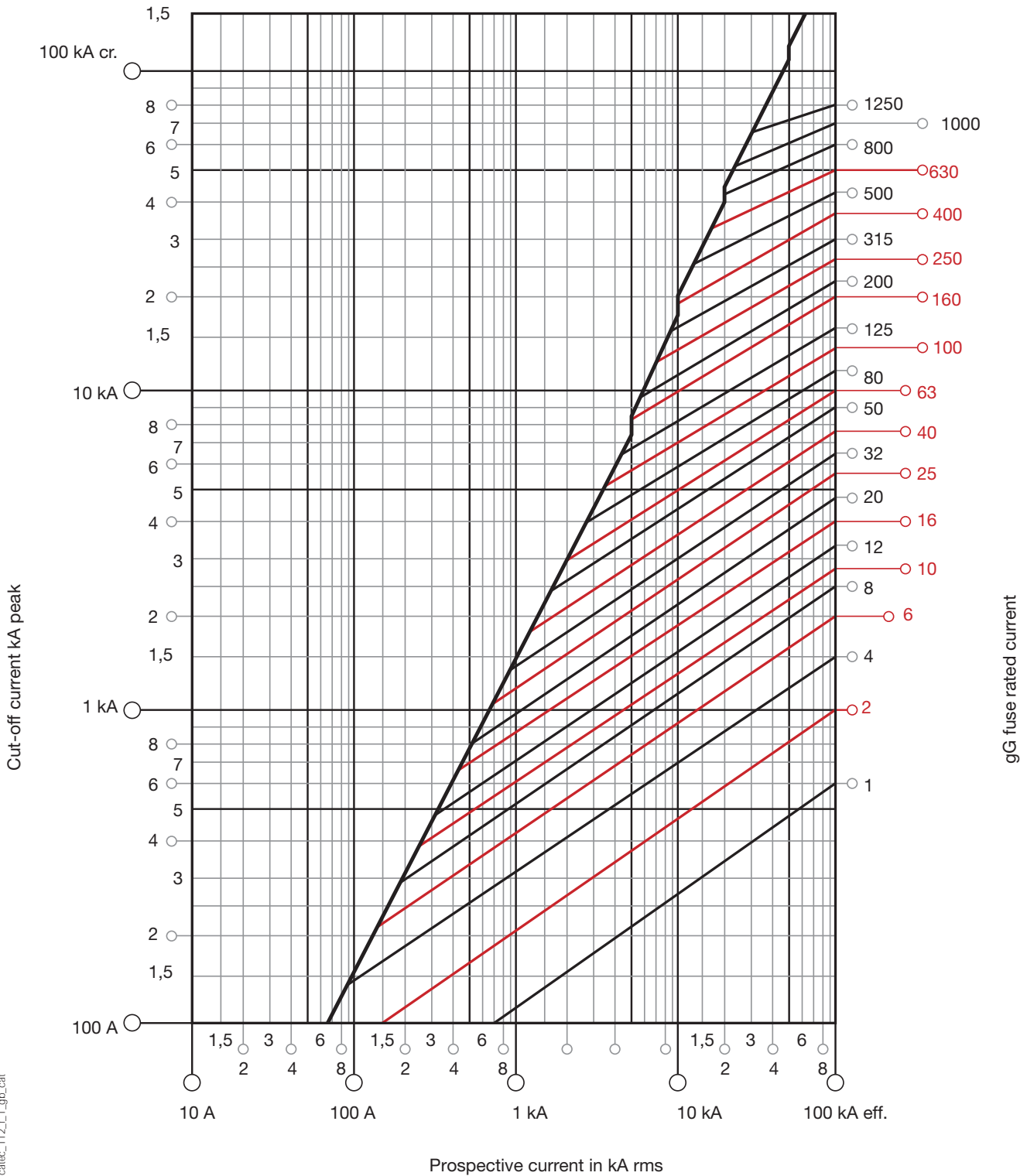

caldec_112_f_1_ggb_cat

Diagram of thermal constraint limitation

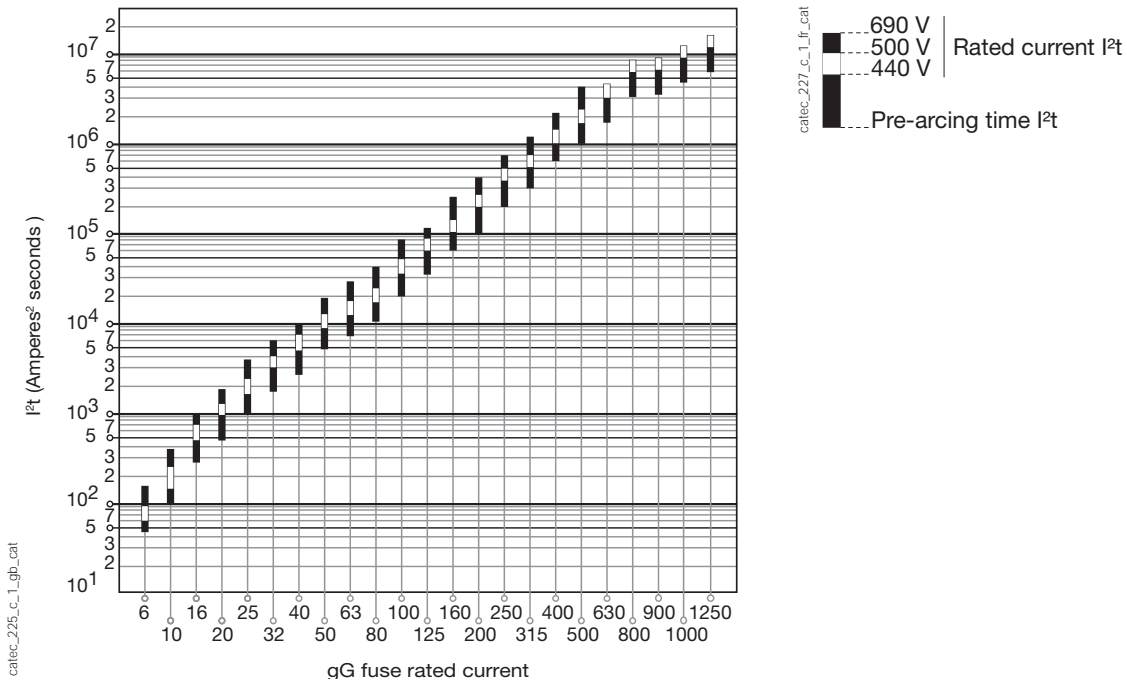

Time/current operation characteristics

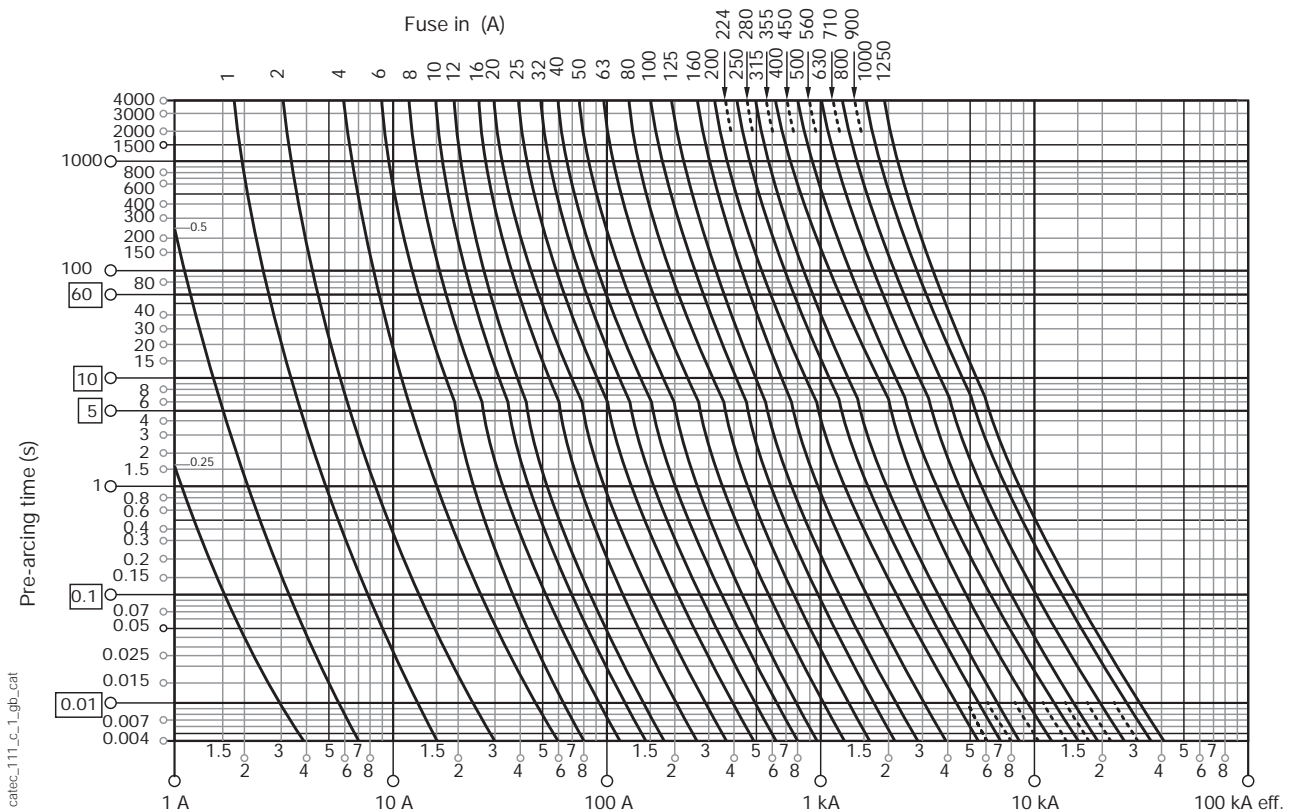

Industrial fuses

NFC-DIN industrial fuselinks gG and aM curves
from 0.5 to 1250 A

Curves characteristic of NF and NH aM type fuses

Cut-off current diagram

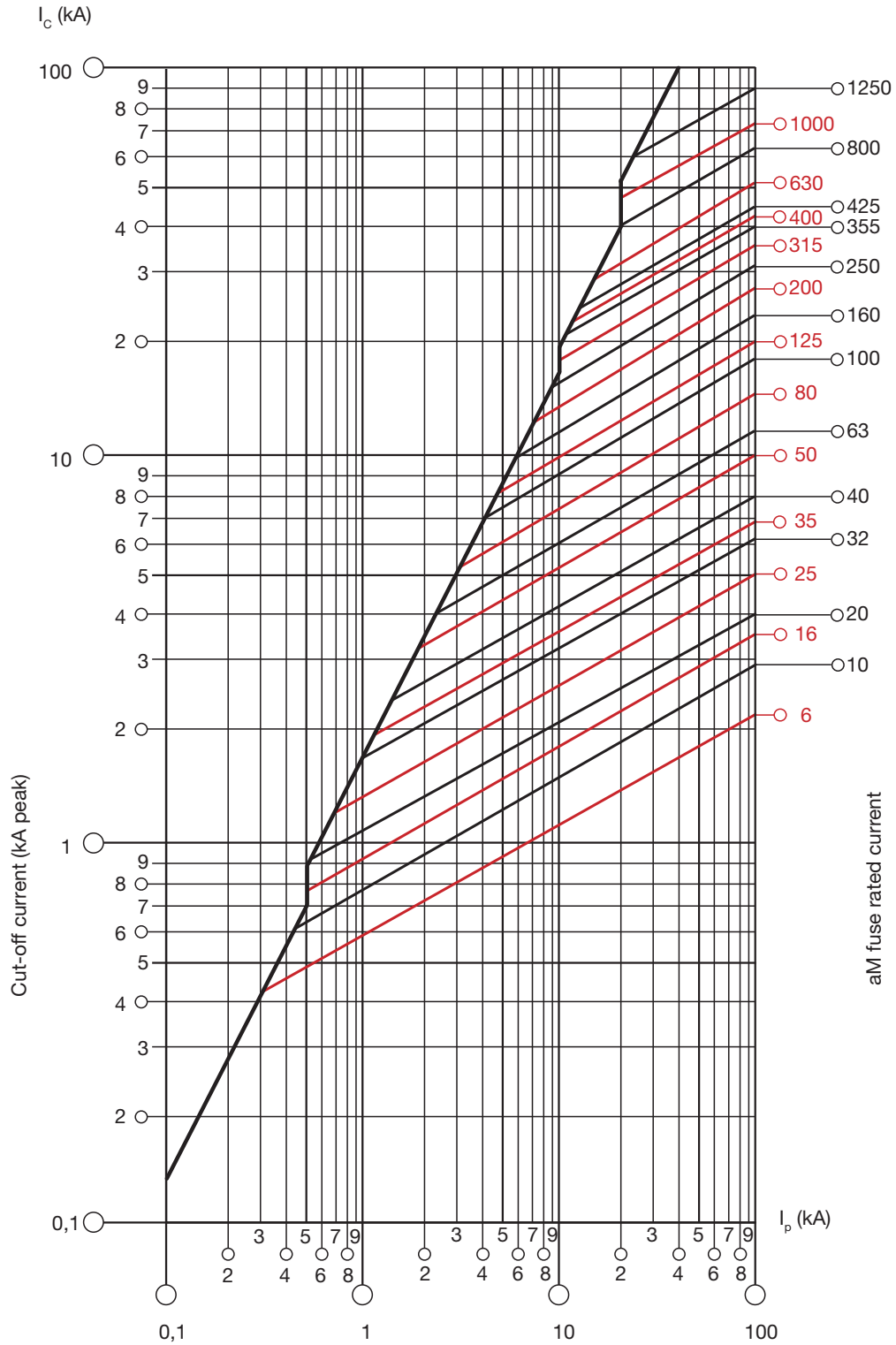

catrec_114_g_1_gpb_cat

Diagram of thermal constraint limitation

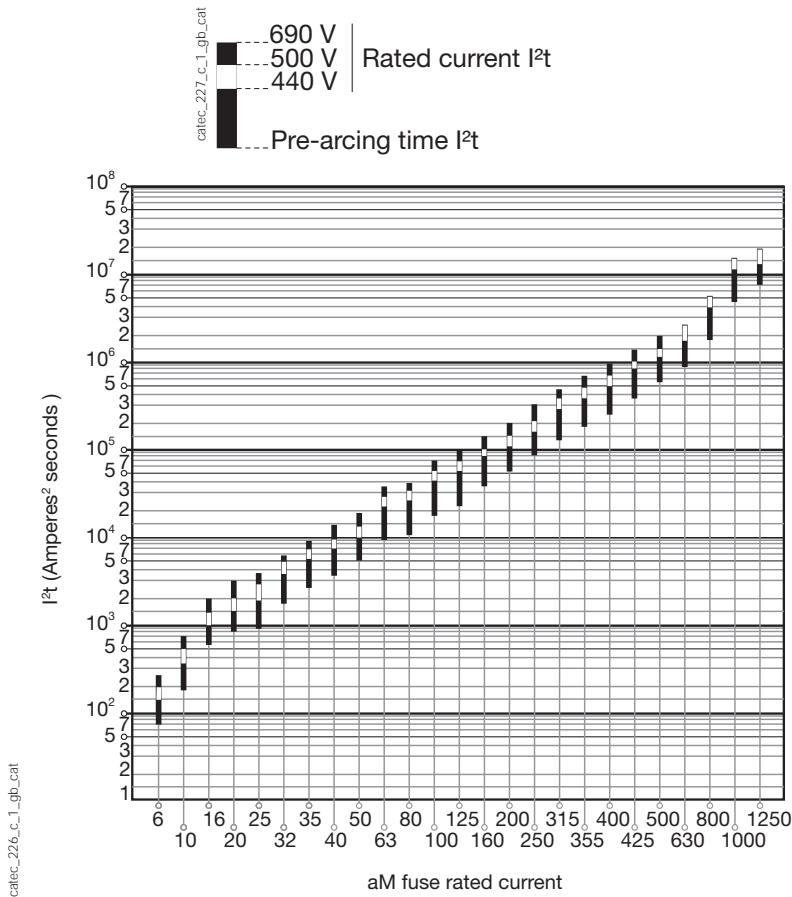

Dissipated power without striker (W)

Rated operational currents I_n (A)	Fuse size			
	000	00	0/0S	1 2 3 4
6	0.33		0.42	
10	0.52		0.67	
16	0.81		0.98	
20	0.92		1.04	
25	1.08		1.17	
32	1.42		1.67	
35	1.58		1.72	
40	1.68		1.91	
50		2.28	2.51	
63		2.9	3.35	3.2
80		4.19	4.93	4.6
100		5.09	5.72	5.7
125		6.29	7.30	6.98 7.6
160		7.73	9.50	9.2 9.7
200			12.3	13.7 13.9
224				14.0 14.0
250				15.3 17.0
315				26.0 20.6 18.8
355				25.2 23.9
400				29.3 26.5 23.5
425				28.3
500				35.8 34
630				56.9 49
800				70
1000				80
1250				108

Time/current operation characteristics

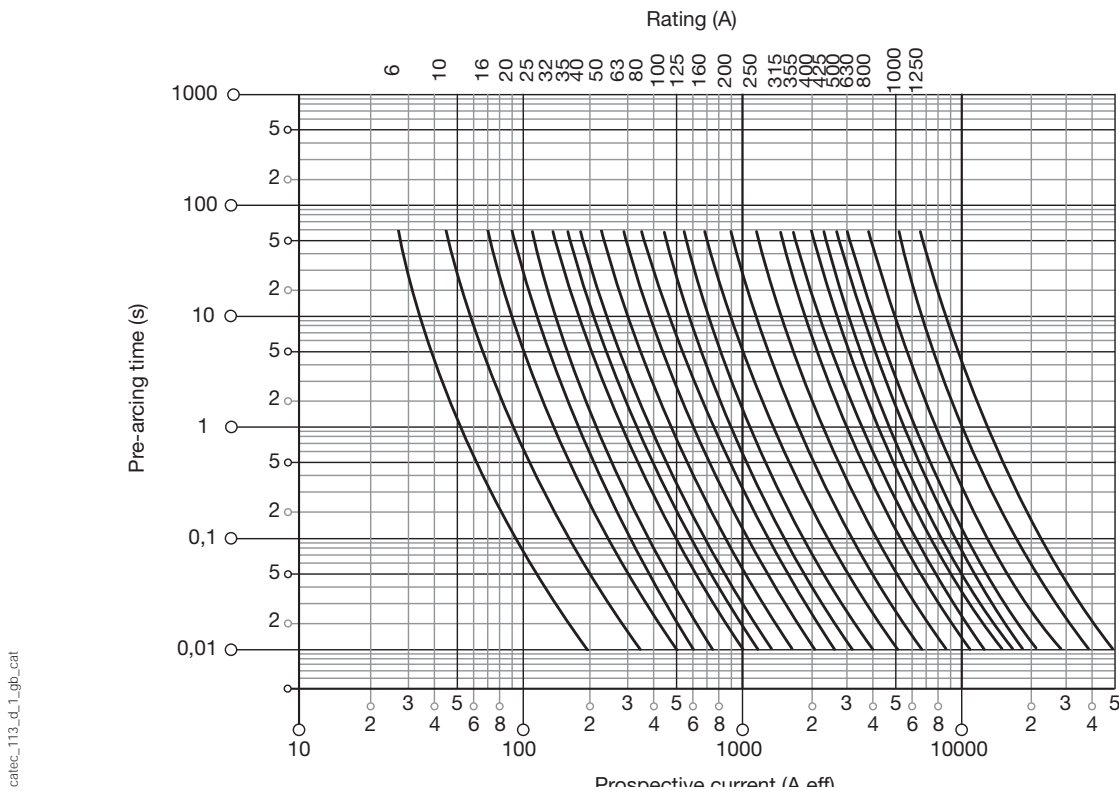

RM PV

Fused disconnect switches

for cylindrical photovoltaic fuses 10 x 38 and 14 x 51



RM PV 10 x 38
32 A



RM PV 14 x 51
50 A

The solution for

- > Small systems up to large PV farms



Strong points

- > Improved safety
- > Product designed for photovoltaic applications
- > Specific format and accessories

Compliance with standards

- > IEC 60269
- > NF EN 60269-1
- > VDE 0636-10
- > DIN 43620
- > UL 4248-18 file E470731
- > CSA 265615



Function

RM PVs are modular unipolar fuse disconnect switches for gPV type cylindrical fuses. They provide safety disconnection and protection against overcurrents caused by the reverse current in DC electrical PV circuits.

RM PVs are fuse disconnect switches with or without light signalling for fuses without strikers.

Advantages

Improved safety

- Rated voltage of 1000 VDC.
- Self-extinguishing thermoplastic materials.
- IP2X protection.

Specific format and accessories

- Modular 45-mm cut-out.
- Interlocking possible with accessory.

Product designed for photovoltaic applications

Protection against reverse currents by using gPV fuses dedicated to photovoltaic applications.

References

No. of poles	32 A 10 x 38		50 A 14 x 51	
	To be ordered in multiples of	Reference	To be ordered in multiples of	Reference
1 P	12	57PV 0001 ⁽¹⁾	6	56PV 1401
1 P with signalling	12	57PV 0L01 ⁽¹⁾		

(1) UL and CSA-certified.

Characteristics according to IEC 60269-2

Thermal current I_{th}	32 A 10 x 38	50 A 14 x 51
Fuse size	10 x 38	14 x 51
Rated insulation voltage U_i (V)	1000	1000
Fuse rating		
Fuse rating (A)	1 ... 20	25 ... 32
Power		
Rated dissipated power (W)	3	5
Derating factor of design current for N poles side by side		
N = 1 ... 3	1	1
N = 4 ... 6	0.8	0.8
N = 7 ... 9	0.7	0.7
N ≥ 10	0.6	0.6
Connection		
Minimum Cu cable cross-section (mm ²)	0.75	1.5
Maximum Cu rigid cable cross-section (mm ²)	10	35
Tightening torques (Nm)	2.5	3
Dimensional data		
Weight of 1 P (kg)	0.057	0.15

Dimensions

RM PV 10 x 38

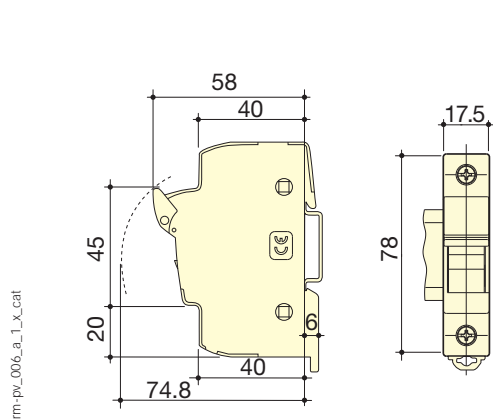

RM PV 14 x 51

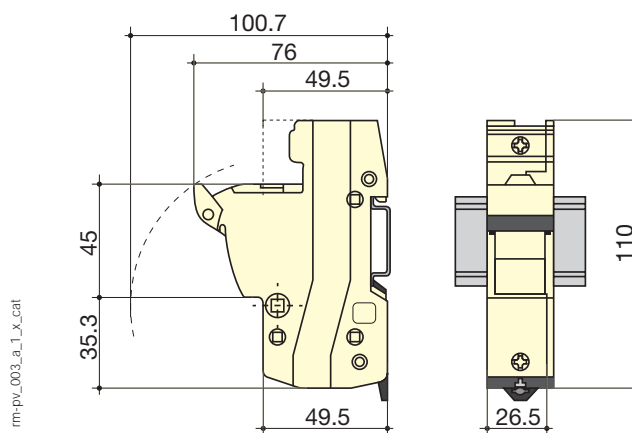

PV fuse bases

Fuse bases for PV applications

for NH gPV fuses from 32 to 500 A, up to 1500 VDC



Base
size 1, 1000 VDC



Base
size 3L, 1500 VDC

The solution for

- > Small installations up to large PV farms



Strong points

- > Improved safety
- > Product dedicated to PV applications
- > Fuse blown indication
- > Different fixing types

Conformity to standards

- > IEC 60269
- > NF EN 60269-1
- > VDE 0636-10
- > DIN 43620



Function

SOCOMECEC **fuse bases** provide fixed, unipolar or multipolar support for knife edge fuses dedicated to PV applications.

Advantages

Improved safety

- Rated voltage of 1000 or 1500 VDC.
- Self-extinguishing thermoplastic material.
- Kit IP2X (depending on models).

Product dedicated to PV applications

Protection against reverse currents thanks to gPV fuses dedicated to PV applications.

Fuse blown indication

Possibility to collect the fuse blown indication (Please see section PV fuses).

Different fixing types

DIN rail or back plate mounting available (depending on models).

References

Back plate mounted device

Rating Fuse size No. of poles	200 A NH1 / 1000 VDC Reference	250 A NH2 / 1000 VDC Reference	400 A NH3 / 1000 VDC Reference	500 A 3L / 1500 VDC Reference
1 P	65PV 1011	65PV 1002	65PV 1003	65PV 1113

Accessories for NH1 fuses	Reference	Reference	Reference
Connecting block - set of 1 piece	6500 0031	6500 0031	6500 0032
Phase separation shield - set of 1 piece	6500 0003	6500 0003	6500 0004
Terminal shrouds - set of 1 piece	6500 0012	6500 0013	6500 0014
Fuse cover - set of 1 piece	6500 0022	6500 0022	6500 0023
Kit IP20 1 P	6511 1011 ⁽¹⁾	6511 1012	6511 1013

(1) IP20 single-pole kit consisting of 2 connecting blocks, 2 phase separation shields, 2 terminal shrouds and 1 fuse cover. Not compatible with C.A.

Dimensions

200 to 160 A - NH1, NH2 & NH3 size / 1000

500 A - 3L size / 1500 VDC

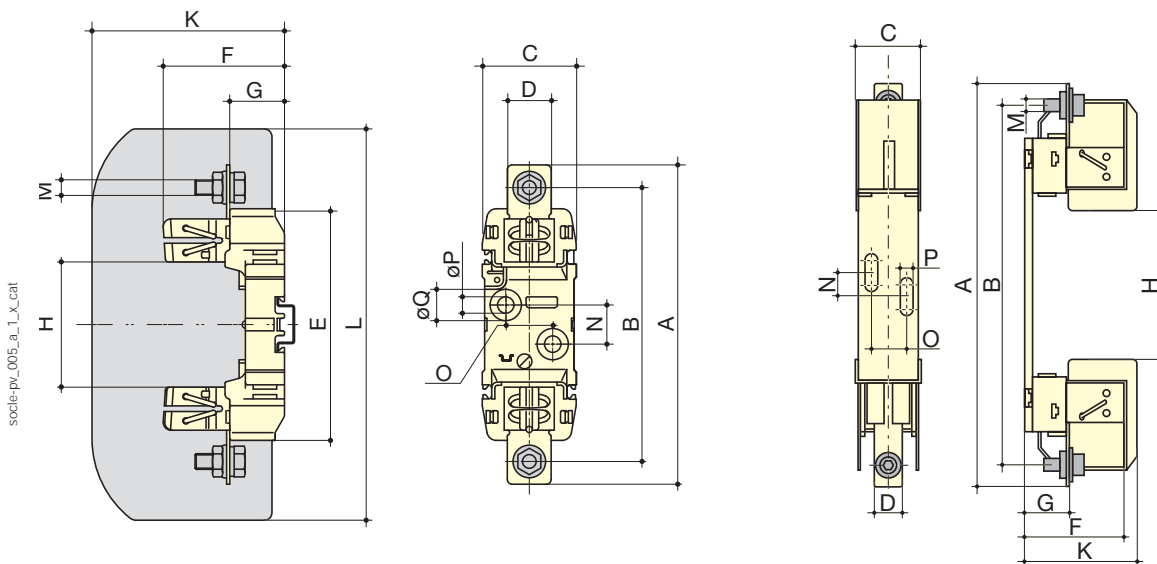

Rating (A)	Fuse size	A	B	C	D	E	F	G	H	K	L	M	N	O	P	Q
200	NH1	200	175	60	28	148	77.5	35	80	123	250	M10	25	30	10.5	20.5
250	NH2	225	200	60	32	148	88	35	80	123	250	M12	25	30	10.5	20.5
400	NH3	240	210	60	38	148	97	35	80	143	270	M12	25	30	10.5	20.5
500	3L	307	270	68	40	-	103	38	140	-	-	M12	25	30	10.5	-

Photovoltaic fuses

gPV curve

10 to 600 A, up to 1000 VDC



The solution for

- > Photovoltaic protection



Strong points

- > High breaking capacity up to 1000 VDC
- > Product designed for photovoltaic systems
- > Increased reliability
- > Improved safety

Extended range

- > Range of switches and sockets, combs and dedicated connection accessories

Compliance with standards

- > IEC 60269-6
- > IEC 60269-1
- > IEC 60269-2



Function

SOCOMECS' gPV fuses protect photovoltaic systems against overcurrents caused by the reverse currents that these systems can generate.

Advantages

High breaking capacity

Up to 50 kA at 1000 VDC.

Product designed for photovoltaic systems

Operating ranges adapted to low overcurrents specific to photovoltaic systems.

Increased reliability

- Absolute protection over time guaranteed by the simplicity of manufacture and function (Joule effect).
- No degradation of fuse characteristics over time.

Improved safety

The energy released whilst eliminating the fault (fuse blowing) is contained within the cartridge (no degassing).

What you need to know

Characteristics used

- I_{SC} : short circuit current of the string.
- $I_{SC\ MAX}$: short circuit current of the string due to maximum sunlight intensity.
- I_{RM} : maximum permitted reverse current.
- I_n : rating or nominal current of the fuse (25 °C in an RM socket).
- N_c : number of strings in parallel.
- U_e : fuse's maximum operating voltage.
- $U_{OC\ MAX}$: maximum open circuit voltage in the lowest temperature conditions.

When to protect

A PV string requires overcurrent protection when its own maximum admissible reverse current characteristic (I_{RM}) is less than the current generated by the rest of the installation (current generated by the other "Nc-1" strings).

How to protect

Protecting from overcurrents involves ensuring that both polarities are functionally grounded whether the DC is connected or not.

How to choose the right fuse protection

Voltage

$$U_e > U_{OC\ MAX}$$

Unless indicated otherwise, use $U_{OC\ MAX} = 1.2 U_{OC}$

Determining the fuse rating

Determining the fuse rating involves choosing a fuse that can:

- Withstand, without blowing, normal overcurrents during sunlight hours and the ambient temperature of the enclosure in which the fuse is installed, $I_n > I_{SC\ MAX}$ Unless indicated otherwise $I_{SC\ MAX} = 1.4 I_{SC}$
- Melt reliably before the modules are damaged by the reverse current. $I_n < I_{RM}$

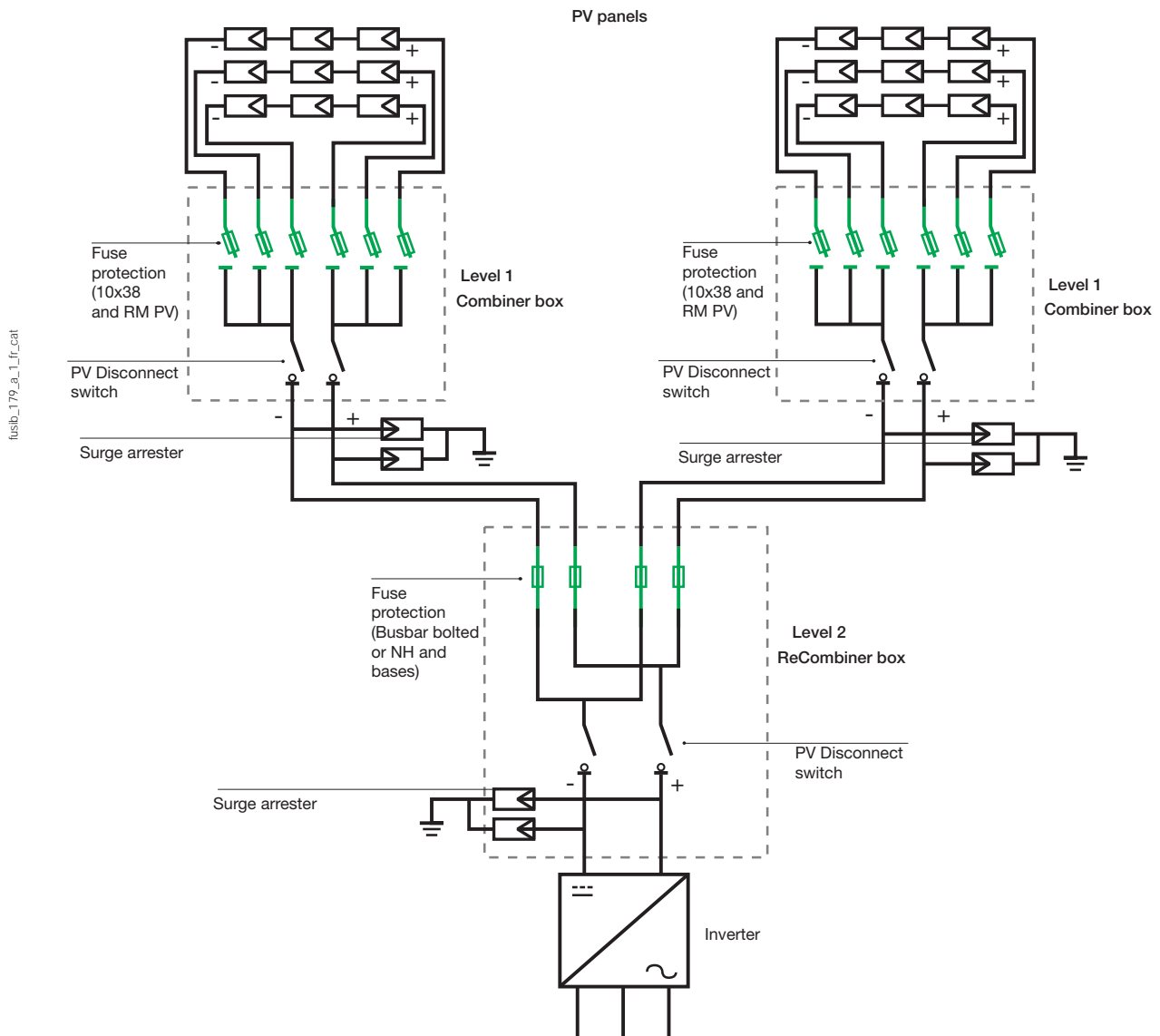

Photovoltaic fuses

gPV curve

from 10 to 600 A, up to 1000 VDC

References

Rated voltage 1000 VDC

Rating (A)	Fuse size	Dissipated power		Breaking capacity	Reference
		W @ In	W @ 0.8 In		
gPV cylindrical fuses					
10	10 x 38	2.58	1.51	30 kA	60PV 0010
12	10 x 38	2.61	1.42	30 kA	60PV 0012
15	10 x 38	2.44	1.08	30 kA	60PV 0015
16	10 x 38	2.70	1.56	30 kA	60PV 0016
20	10 x 38	2.99	1.75	30 kA	60PV 0020
gPV knife blade fuse					
32	NH1	8.5	4.3	50 kA	60PV 0032
40	NH1	9	4.6	50 kA	60PV 0040
50	NH1	10.5	5.4	50 kA	60PV 0050
63	NH1	12	6.1	50 kA	60PV 0063
80	NH1	15.5	7.9	50 kA	60PV 0080
100	NH1	16.5	8.4	50 kA	60PV 0100
125	NH1	17.5	8.9	50 kA	60PV 0125
160	NH1	24	12.2	50 kA	60PV 0160
200	NH1	25	13	50 kA	60PV 1200
250	NH2	35	23	50 kA	60PV 1250
315	NH3	44	27	50 kA	60PV 1315
400	NH3	50	30	50 kA	60PV 1400
500	3 L	85	50	50 kA	60PV 0500
600	3 L	118	92	50 kA	60PV 0600

Accessories

Accessories	Size NH1 Reference	Size NH2 Reference	Size NH3 Reference	Size 3L Reference
Fuse blown auxiliary contact	56PV 9901	56PV 9901	56PV 9901	56PV 9901
Fuse base recommended	65PV 1011	65PV 1002	65PV 1003	65PV 1113

Adjustment due to ambient temperature

$$I_{nf} = I_{scgen} / K_t$$

I_{nf} - gPV fuse rated current.

I_{scgen} - short-circuit current of PV generator in STC conditions.

K_t - correction factor.

Max. ambient temperature (°C)	Kt: correction factor
20	1
40	0.92
45	0.90
50	0.87
55	0.85
60	0.82
65	0.79
70	0.76

Standard dimensions (mm) as per IEC 60269-2

gPV cylindrical fuses

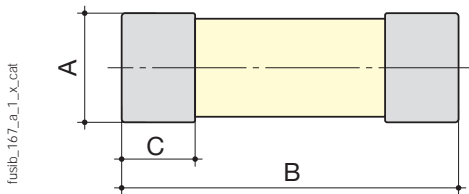

Fuse size	Striker	A	B	C
10 x 38	Without	10.3	38	10.5
14 x 51	Without	14.3	51.5	10.10
10 x 85	Without	10.3	85	10.5

gPV knife edge fuse

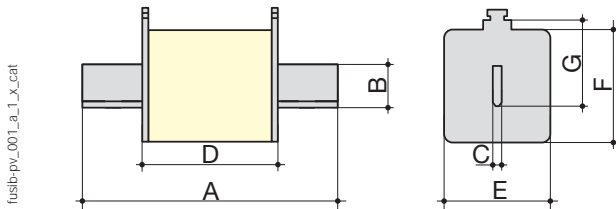

Fuse size	Striker	A max	B	C	D max	E max	F max	G
NH1	Without	137	20	6	68	40	53	40
NH2	Without	152	25	6	75	60	61	48
NH3	Without	152	32	6	75	70	75	60
1XL	Without	190	20	6	128	51	51	40
3L	Without	205	32	6	123	74	74	60

Photovoltaic fuses

gPV curve

from 10 to 600 A, up to 1000 VDC

Time/current operational characteristics

Rated voltage 1000 VDC

gPV cylindrical fuses 10x38

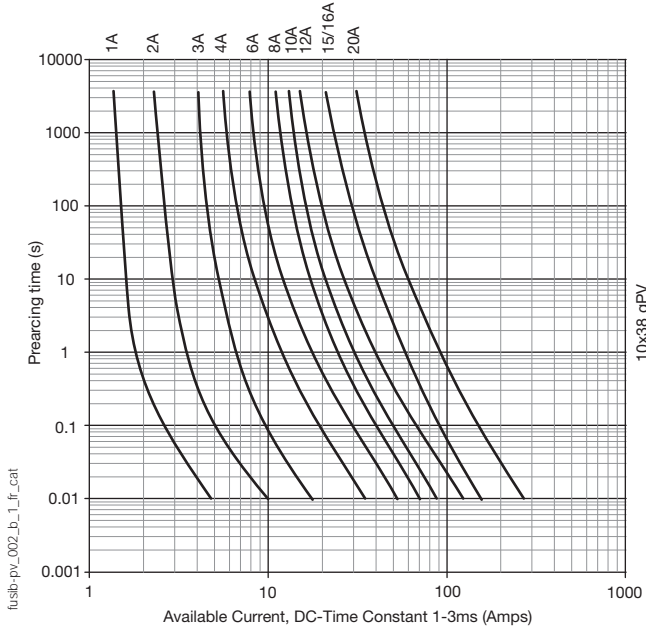

gPV cylindrical fuses 14x51

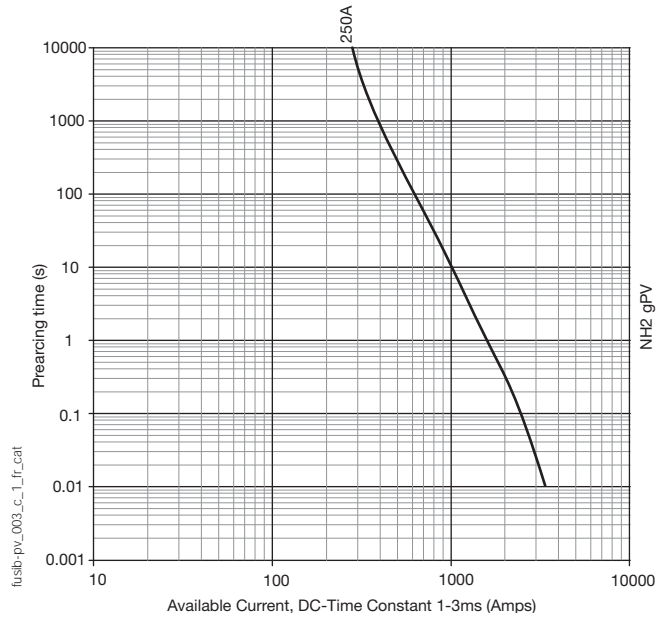

gPV NH1 knife blade fuses

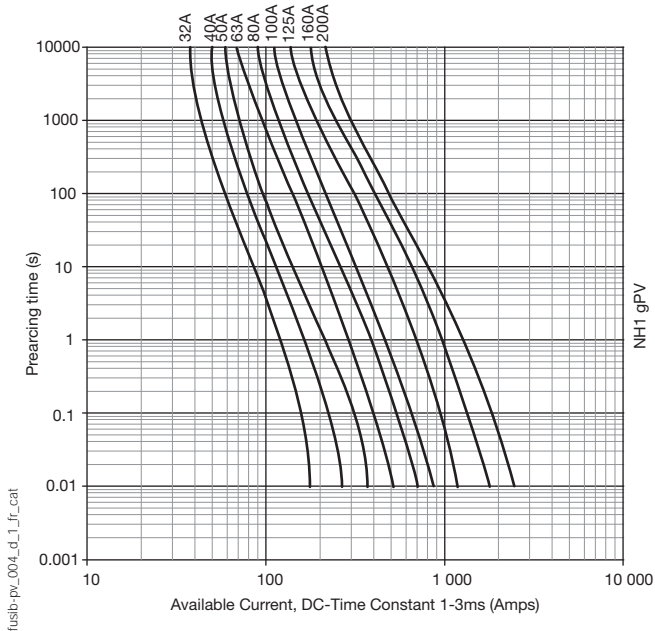

gPV NH2 knife blade fuses

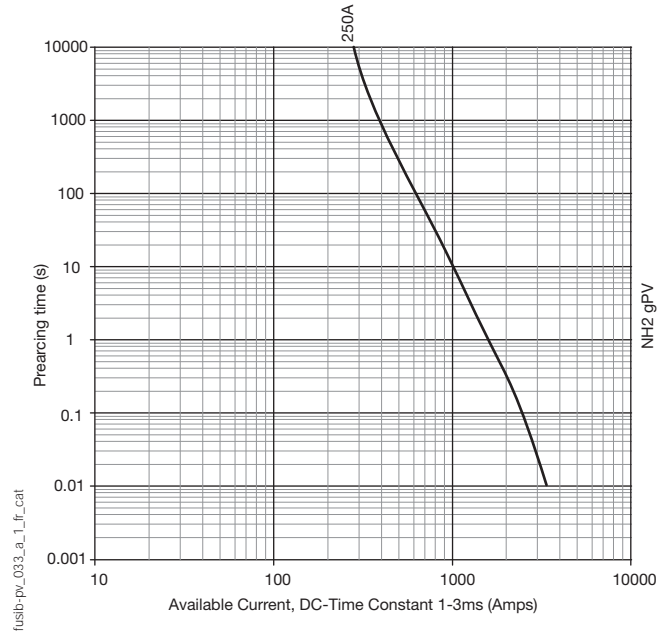

Rated voltage 1000 VDC (continued)

gPV NH3 knife blade fuses

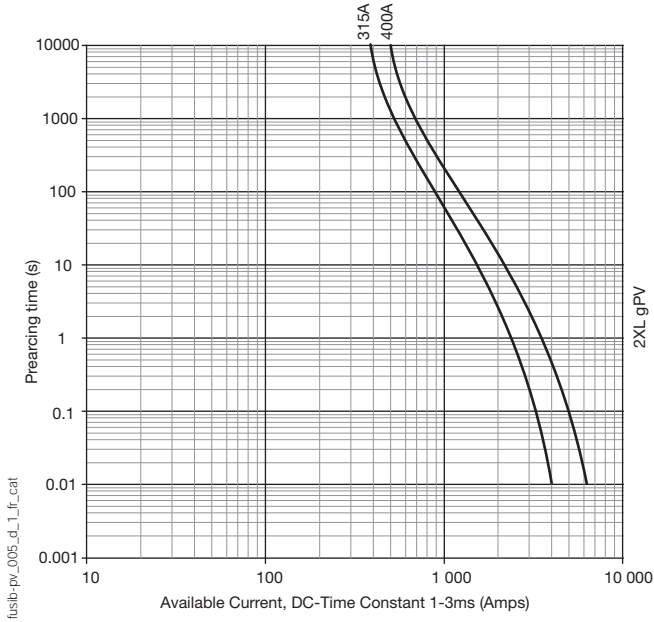

gPV 3L knife blade fuses

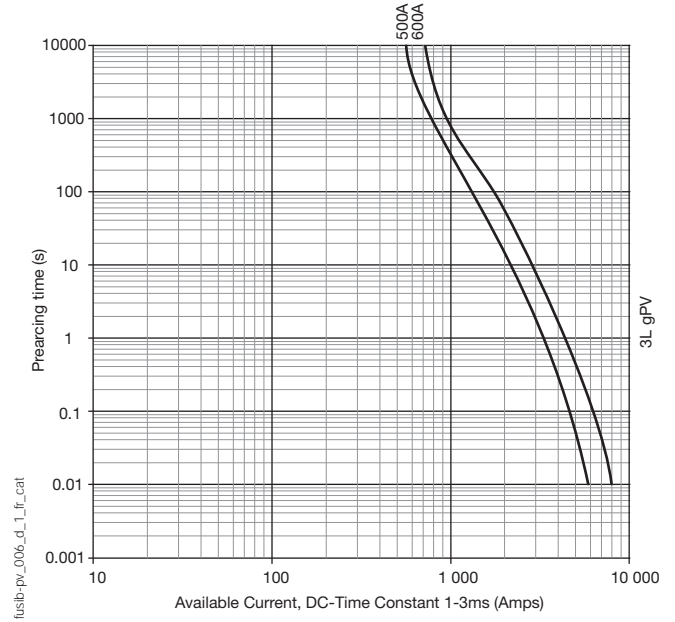

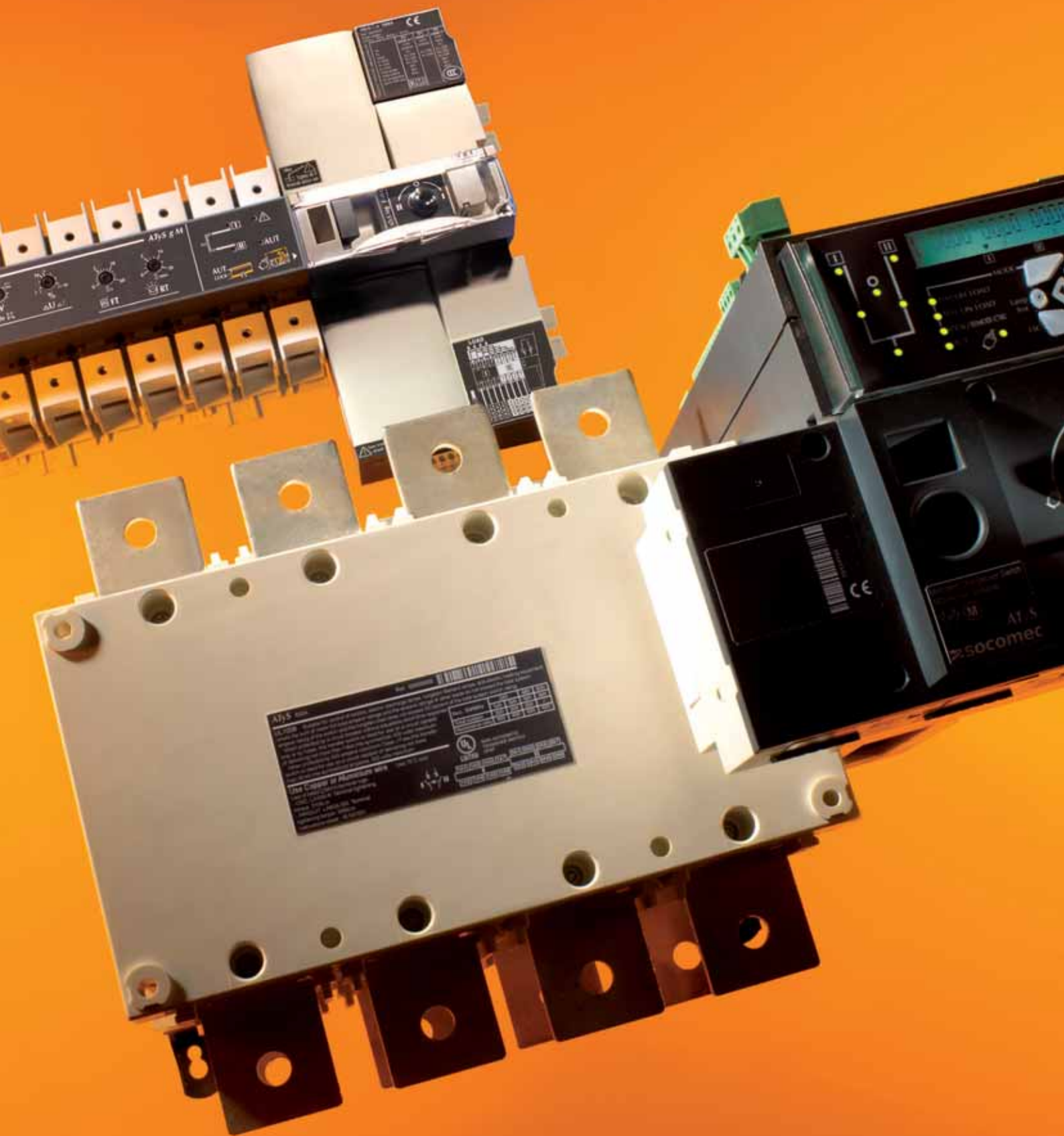

Transfer switches

Security and reliability for your transfer applications p. 202

Manually operated Transfer Switching Equipment selection guide p. 204

Remotely operated and Automatic Transfer Switching Equipment selection guide p. 206

ATS Controller selection guide p. 208

Manual transfer switches



COMO CS
25 to 100 A
p. 210



SIRCOVER
125 to 3200 A
p. 216

Motorised modular transfer switches

ATyS M range p. 234
40 to 160 A



ATyS d M
p. 236



ATyS t M
ATyS g M
p. 238



ATyS p M
p. 240

Motorised transfer switches

ATyS S range p. 248
40 to 6300 A

ATyS range p. 256



ATyS S
ATyS d S
p. 250



ATyS r
p. 258



ATyS g
p. 260



ATyS p
p. 262



ATyS d H
p. 280

Universal ATS controller

Automatic control of different switching technologies: circuit breakers, contactors, switches.



ATyS C25
p. 282



new
ATyS C35
p. 284



ATyS C55
p. 286



ATyS C65
p. 288

UL product range

UL range p. 290



SIRCOVER UL1008
100 to 1200 A
Consult us



ATyS UL1008
100 to 400 A
Consult us

Enclosed solutions

SOCOMEC offers a range of pre-equipped enclosures in steel or polyester.



Enclosed
SIRCOVER
Consult us



Enclosed
ATyS M
Consult us



Enclosed
ATyS
Consult us

Any particular requirement?

Thanks to our extensive experience we have developed an impressive portfolio of customised solutions (motorised transfer switches with overlapping contacts and cooled poles, specific software, etc.). Please contact us if you have any specific requests.

For all your applications, even the most critical, trust the experts.

Security and reliability for your transfer applications

An undisputed leader in the field of changeover switching, SOCOMEC is continuously innovating to ensure the continuity of electrical distribution.

From the COMO CS manual transfer switch (25 - 100 A) to the ATyS p automatic transfer switch (up to 3200 A) and the ATyS d H remotely operated transfer switch (up to 6300 A), our range of changeover switches cover most applications as standard.

Products for all switching applications from 25 to 6300 A

SOCOMECS transfer switches can be used not only for normal/emergency source switching, but also to manage the switching of loads or for earthing/earthing solutions.

Your application	Manual changeover switches	Motorised changeover switches	Automatic changeover switches
Changeover switches (network/network - network/genset - genset/genset)	•	•	•
Bypass application	•	•	•
Other AC applications (load switching - grounding/earthing - phase switching)	•		
Photovoltaic applications	•		

Secure switching for all your transfers

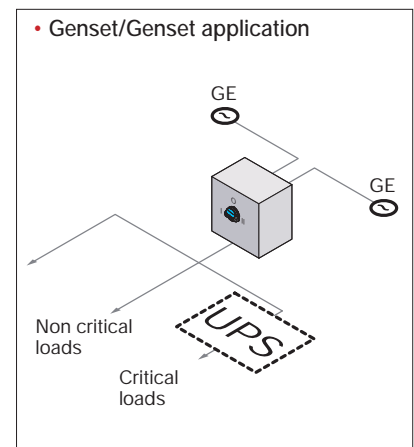
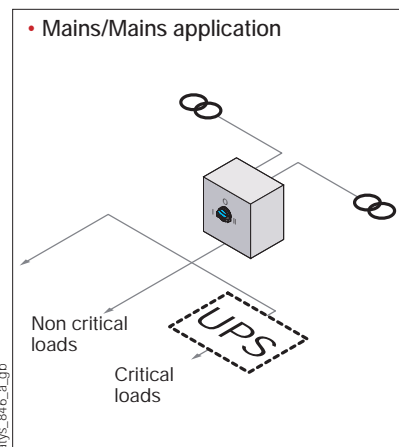
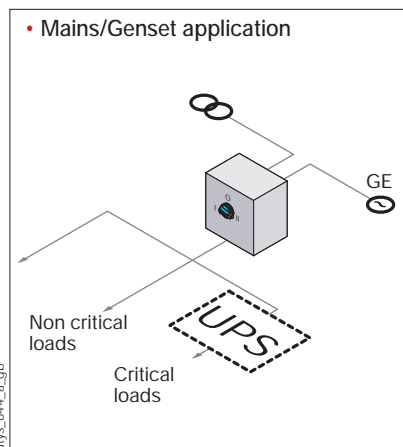

Expert Services

- > Study, definition, advice, implementation, maintenance and training...
- > Our Expert Services extend to a complete offer of customised services to make your project a success.



Secure switching compliant with standard IEC 60947-6-1

The standard IEC 60947-6-1 “Low-voltage switchgear and controlgear – Multiple function equipment – Transfer Switching Equipment” is dedicated to changeover switches.

This standard applies to Transfer Switching Equipment (TSE) with interruption of the supply to the load during transfer, the rated voltage of which does not exceed 1000 VAC or 1500 VDC, be it any of the following:

- **MTSE**
According to the standard IEC 60947-6-1, MTSE (Manually operated Transfer Switching Equipment) is manually operated transfer switching equipment. As such, it requires a person to be present to operate the handle.
- **RTSE**
According to the standard IEC 60947-6-1, RTSE (Remotely operated Transfer Switching Equipment) is transfer switching equipment that is controlled remotely. As such, they require an external controller to provide them with commands.
- **ATSE**
According to the standard IEC 60947-6-1, ATSE (Automatic Transfer Switching Equipment) is transfer switching equipment that is controlled automatically. It differs from RTSE in that it has an integrated controller. As such, these devices are self-monitoring in terms of power source availability, and will start up the genset if required and switch automatically to the power source that is present.

This standard also defines categories of use, depending on the needs of the application, which may apply to the TSE:

Type of current	Utilisation category		Type of load
	Application A ⁽¹⁾	Application B ⁽²⁾	
Alternating current	AC-31A	AC-31B	Non-inductive or low-inductive loads
	AC-32A	AC-32B	Mixed resistive and inductive loads, including moderate overvoltages
	AC-33A	AC-33B	Motors or various loads including motors, resistive loads and loads comprising up to 30% incandescent lamps

(1) Application A: Frequent switching.
(2) Application B: Infrequent switching.

UL applications

SOCOMECL 1008 transfer switches are designed for use in “total system optional standby power” applications with a secure transfer of load power between a regular source and a backup source.

“Optional standby systems” are installed to provide a backup power supply for buildings where a power failure could mean disruption, interruptions to operation or damage to products or processes.

Selection guide

Manually operated Transfer Switching Equipment

How many poles?



What type of operations?

		
	COMO CS 25 to 100 A <i>p. 210</i>	
Number of poles		
3 P		•
4 P		•
Switch operation		
I-0-II		•
I-I+II-II		•
Bypass		•
Indication of breaking		
Positive break indication		•
Operating handle		
Front direct/external operation		•
Door mountable switch		•

(1) Depending on the version. From 125 to 3200 A for SIRCOVER I-0-II; from 125 to 1800 A for SIRCOVER I-I+II-II and from 125 to 1600 A for SIRCOVER Bypass.

What type
of breaking
indication?



SIRCOVER
125 à 3200 A ⁽¹⁾
p. 216

•

•

•

•

•

•

•

Selection guide





Remotely operated and Automatic Transfer Switching Equipment

ATyS

Which type of power supply?



Which application?

RTSE (Remotely operated)				
40 to 125 A	40 to 160 A	125 to 3200 A	4000 to 6300 A	
				
<i>ATyS S</i> p. 250	<i>ATyS d S</i> p. 250	<i>ATyS d M</i> p. 236	<i>ATyS r</i> p. 258	<i>ATyS d H</i> p. 280

Type of power supply

Power supply 12, 24 or 48 VDC	•				
Single power supply 230 VAC	•			•	
Dual power supply 230 VAC		•	•		•

Connection of remote control interface

D10					
D20					

Application

Mains/Mains	• (1)	• (1)	• (1)	• (1)	• (1)
Mains/Genset	• (1)	• (1)	• (1)	• (1)	• (1)
Genset/Genset	• (1)	• (1)	• (1)	• (1)	• (1)

Configuration

Configuration using potentiometers and dip switches					
Configuration using display and keyboard					
Voltage and frequency auto-configuration					

Functions

Contact for product availability				•	
Fixed function inputs/outputs (defined by the factory)	•	•	•	•	•
Configurable inputs/outputs					
Voltage and frequency checks					
Phase rotation check					
Unbalanced phase check					
LED indication of source availability					
LED position indication					
Programming of genset startup					
Genset connected on switch II	•	•	•	•	•
Genset connected on switch I	•	•	•	•	•
Test On Load					
Test Off Load					
Load shedding					
Display and measurement of powers and energy (when utilising CTs)					

Supervision

Programming of genset startup					
RS485 communication					
Ethernet communication					
Websserver via Ethernet module					
Data logging					



- (1) With an external controller.
 (2) Only on two pole versions.
 (3) Only available on the version with COM.
 (4) Configurable output.

Selection guide

ATS Controller

Which type of power supply?

Which application?

Classic functions	Simple and digital functions
	 new
ATyS C25 <i>p. 282</i>	ATyS C35 <i>p. 284</i>

Power supply

	Classic functions	Simple and digital functions
AC Supply voltage Phase-Neutral	184-300 VAC	184-300 VAC
AC Supply voltage Phase-Phase	N/A	N/A
Frequency supply range	45-65 Hz	45-66 Hz
DC Supply voltage (optional)	12-24 VDC	12-24 VDC
Powered by USB port		
30s energy backup during blackout		
Integrated external DPS to switch (6A AC1) ⁽²⁾	•	•
Internal DPS from voltage sensing ⁽³⁾	•	•

Measurement

	Classic functions	Simple and digital functions
Voltage measurement range	90-520 VAC (Phase-phase)	90-520 VAC (Phase-phase)
Voltage measurement accuracy		
Frequency measurement accuracy		
Phase angle measurement		•
Current / Power / and energy measurement		

Application

	Classic functions	Simple and digital functions
RTSE class compatibility	PC (switch based) / CC (contactor)	PC (switch based) / CC (contactor) / CB (circuit breaker)
Main-Main	•	•
Main-Gen	•	•
Gen-Gen		

HMI

	Classic functions	Simple and digital functions
LCD Screen		96x64 pixels
Wizard configuration		
Remote display (D70 / D50)		
Compatible with webview (D70/M70)		
Configuration with ECS		

Communication

	Classic functions	Simple and digital functions
RS485 - Modbus	•	•
Digibus (digiware RJ45 connexion)		

Functions

	Classic functions	Simple and digital functions
Tests	On load	On load / Off-load
Inhibition	•	•
Password protection		1 level
Breaker trip management		
In-phase transfer		
Genset Cyclers		
Genset scheduler		
Bypass timers		
Configurable alarms		
Event recording		
Load shedding		

I/O

	Classic functions	Simple and digital functions
Inputs	5 fixed	4 fixed 3 programmable
Outputs	4 fixed	4 fixed 1 programmable ⁽¹⁾



Environment

	Classic functions	Simple and digital functions
IP rating (front face)	IP4X	IP4X
IK	IK 08	IK 08
EMC (according to IEC 61326-1 & IEC 60947-6-1)	Class A	Class A
Overvoltage category	III	III
Pollution CAT	PD 2	PD 2
Temperature use range	-25 - +70°C	-25 - +70°C

(1) In Main-Main mode only fixed in Main-Gen. (2) Supplies voltages from both source to motor. (3) Product can be powered by both sources.

Functionalities?

Digiware connectivity

	Smart functions	Connected functions
		
	ATyS C55 <i>p. 286</i>	ATyS C65 <i>p. 288</i>
	N/A	N/A
	80-576 VAC	80-576 VAC
	45-66 Hz	45-66 Hz
	9-28 VDC	9-28 VDC
	•	•
	•	•
	•	•
	50-576 VAC	50-576 VAC
	0.5%	0.5%
	0.1%	0.1%
	•	•
	•	•
	PC (switch based) / CC (contactor) / CB (circuit breaker)	PC (switch based) / CC (contactor) / CB (circuit breaker)
	•	•
	•	•
	•	•
	350x160 pixels	350x160 pixels
	•	•
	•	•
	•	•
	•	•
	•	•
	On load / Off-load	On load / Off-load
	•	•
	3 level	3 level
	•	•
	•	•
	•	•
	1 program	4 programs
	•	•
	•	•
	300 events	3000 events
	basic load shed	Basic & smart load shed
	6 programmable	6 programmable (+24 optional)
	6 programmable	6 programmable (+18 optional)
	IP4X (IP65 with gasket)	IP 65
	IK 08	IK 08
	Class A & B	Class A & B
	III	III
	PD 3	PD3
	-30 - +70°C	-30 - +70°C

COMO CS

Manual Cam Transfer Switches
from 25 to 100 A



COMO CS - Door mounting
I-II 3 P 25 A



COMO CS in enclosure
I-0-II 3 P 40 A

The solution for

- > Industry (machine control)



Strong points

- > Simple installation
- > Quick mounting
- > Effective in all circumstances

Compliance with standards

- > IEC 60947-3



- > UL 60947-4-1



* cULus under certification.

Function

COMO CS are manually operated multi-pole transfer switches. They ensure switching, transfer of sources or transfer of two low voltage circuits on load as well as their safe disconnection.

Advantages

Simple installation

The "quick fix" allows significant time saving in fixing the handle to the device. The devices sold in enclosed version are ready for installation.

Quick mounting

The accessories offered are common to all the products in the range. The products are designed for installation:

- on the rear of the cabinet on a backplate,
- on the rear of the cabinet on a DIN rail,
- on the door with a direct handle.

Effective in all circumstances

The devices are available with 3 standard switching types that can cover a wide variety of applications:

- I-II
- I-0-II
- I-0-II with bypass

Please consult us for adaptations to specific wiring diagrams.

Configurations

Backplate switch mounted with external handle

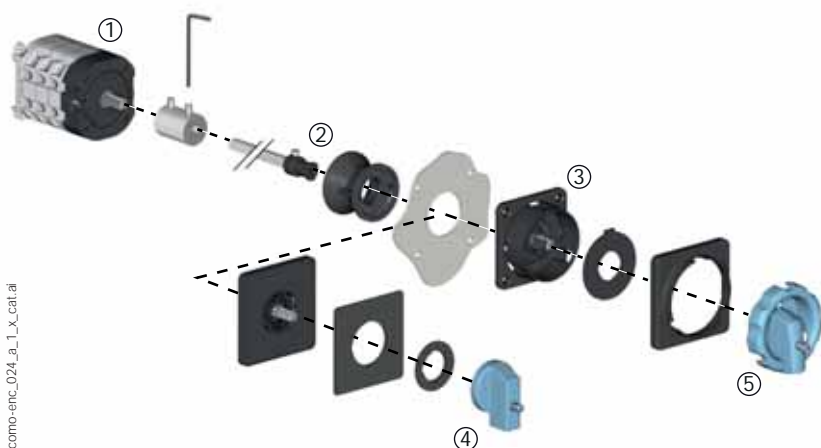

Functional diagram (for further details see the installation instructions supplied with the product).
1. Shaft extension

- 2. Shaft guide
- 3. Signalling plate
- 4. Non padlockable handle

Direct quickfixing handle for door or backplate mounted switch

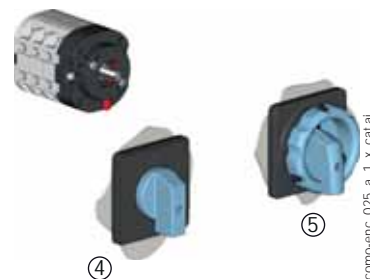

- 5. Padlockable handle

References

COMO CS

Backplate mounting with direct quickfixing handles or external handles

Rating (A)	N° of poles	Switching type	Switch body rear mounting ⁽¹⁾	Padlockable direct quick fixing handle	Non-padlockable direct quick fixing handle	Padlockable external handle ⁽²⁾	Non-padlockable external handle ⁽²⁾
25 A	3 P	I - II	4320 3002	Blue/Black 4359 3042 Red/Yellow 4359 3043	Blue/Black 4359 3022	Blue/Black 4359 1042 Red/Yellow 4359 1043	Blue/Black 4359 2022
	4 P	I - II	4320 4002				
	3 P	I - 0 - II	4330 3002				
	4 P	I - 0 - II	4330 4002				
	3 P	Bypass I - 0 - II	4350 3002				
	4 P	Bypass I - 0 - II	4350 4002				
40 A	3 P	I - II	4320 3004				
	4 P	I - II	4320 4004				
	3 P	I - 0 - II	4330 3004				
	4 P	I - 0 - II	4330 4004				
	3 P	Bypass I - 0 - II	4350 3004				
	4 P	Bypass I - 0 - II	4350 4004				
63 A	3 P	I - II	4320 3006				
	4 P	I - II	4320 4006				
	3 P	I - 0 - II	4330 3006				
	4 P	I - 0 - II	4330 4006				
	3 P	Bypass I - 0 - II	4350 3006				
	4 P	Bypass I - 0 - II	4350 4006				
100 A	3 P	I - II	4320 3010				
	4 P	I - II	4320 4010				
	3 P	I - 0 - II	4330 3010				
	4 P	I - 0 - II	4330 4010				
	3 P	Bypass I - 0 - II	4350 3010				
	4 P	Bypass I - 0 - II	4350 4010				

(1) Mounting on DIN rail and backplate from 25 to 40 A and mounting on backplate for ratings from 63 to 100 A.

(2) Delivered with shaft and plate for front external control.

Door mounting with direct quickfixing handles

Rating (A)	N° of poles	Switching type	Switch body mounting on door	Padlockable direct quick fixing handle	Non-padlockable direct quick fixing handle
25 A	3 P	I - II	4320 3102	Blue/Black 4359 3042 Red/Yellow 4359 3043	Blue/Black 4359 3022
	4 P	I - II	4320 4102		
	3 P	I - 0 - II	4330 3102		
	4 P	I - 0 - II	4330 4102		
	3 P	Bypass I - 0 - II	4350 3102		
	4 P	Bypass I - 0 - II	4350 4102		
40 A	3 P	I - II	4320 3104		
	4 P	I - II	4320 4104		
	3 P	I - 0 - II	4330 3104		
	4 P	I - 0 - II	4330 4104		
	3 P	Bypass I - 0 - II	4350 3104		
	4 P	Bypass I - 0 - II	4350 4104		
63 A	3 P	I - II	4320 3106		
	4 P	I - II	4320 4106		
	3 P	I - 0 - II	4330 3106		
	4 P	I - 0 - II	4330 4106		
	3 P	Bypass I - 0 - II	4350 3106		
	4 P	Bypass I - 0 - II	4350 4106		
100 A	3 P	I - II	4320 3110		
	4 P	I - II	4320 4110		
	3 P	I - 0 - II	4330 3110		
	4 P	I - 0 - II	4330 4110		
	3 P	Bypass I - 0 - II	4350 3110		
	4 P	Bypass I - 0 - II	4350 4110		

Other solutions with enclosures

General characteristics



como-enc_019.eps

- Available for switching types I-II and I-0-II
- Different enclosure sizes adapted to your needs.
 - Maximum safety during maintenance operations due to triple padlocking of the handle in position 0 (position I for switching type I-II).
 - IP 65 / NEMA 4, 4X : When installed in an industrial environment, protection degree IP 65 and NEMA 4, 4X ensures that the products are protected against dust and water jets.
 - Red-yellow operating handle.

References

Rating (A)	No. of poles	Switching type	Reference
25 A	3 P	I - II	4321 3C02
	4 P	I - II	4321 4C02
	3 P	I - 0 - II	4331 3C02
	4 P	I - 0 - II	4331 4C02
40 A	3 P	I - II	4321 3C04
	4 P	I - II	4321 4C04
	3 P	I - 0 - II	4331 3C04
	4 P	I - 0 - II	4331 4C04
63 A	3 P	I - II	4321 3C06
	4 P	I - II	4321 4C06
	3 P	I - 0 - II	4331 3C06
	4 P	I - 0 - II	4331 4C06
100 A*	3 P	I - II	4321 3C10
	4 P	I - II	4321 4C10
	3 P	I - 0 - II	4331 3C10
	4 P	I - 0 - II	4331 4C10

* For an ambient temperature of 35 °C

Dimensions (in/mm)

25 to 40 A

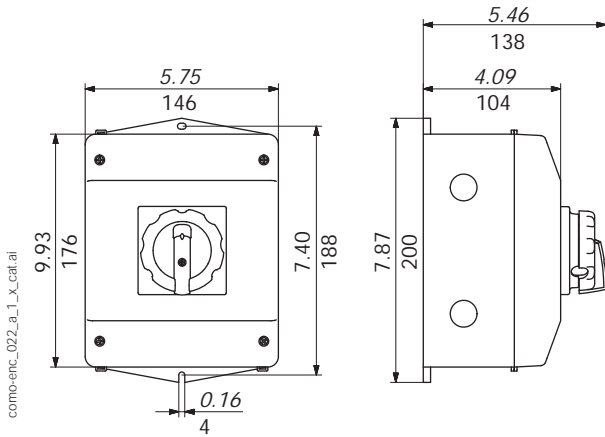

63 to 100 A

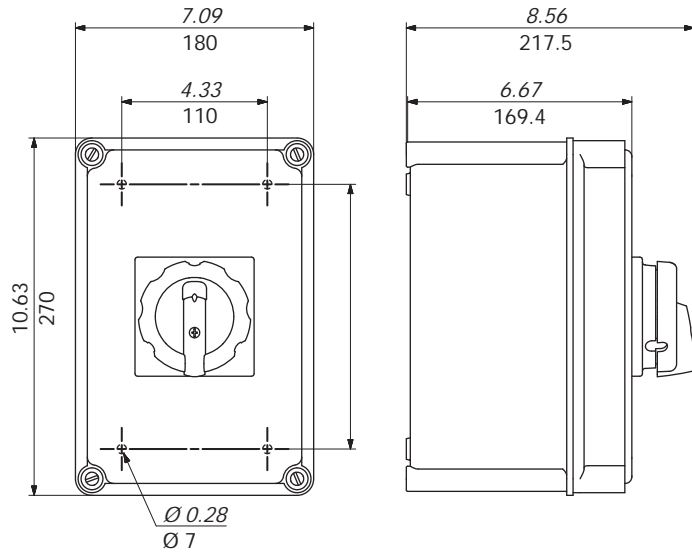

Characteristics according to IEC 60947-3

25 to 100 A

Conventional free air thermal current I_{th} at 40 °C (A)	25 A	40 A	63 A	100 A
Conventional free air thermal current I_{th} at 50 °C (A)	25	34	63	100
Conventional free air thermal current I_{th} (60 °C) (A)	19	24	53	90
Rated insulation voltage U_i (V)	690	690	690	690
Rated impulse withstand voltage U_{imp} (kV)	4	6	6	6
Rated operational currents I_e (A)				
Utilisation category at 400 VAC				
AC-21A	25	40	63	100
AC-22A	20.5	40	63	100
AC-23A	15	29	63	63
AC-3	12	22	/	/
Utilisation category at 690 VAC				
AC-21A	25	40	63	100
AC-22A	20.5	40	63	100
AC-23A	8.5	17	63	63
AC-3	7	12.8	/	/
Operational power in AC-23 (kW)⁽¹⁾				
At 400 VAC without pre-break AC	7.5	15	37	37
At 690 VAC without pre-break AC	4.8	15	/	/
Fuse protected short-circuit withstand with gG DIN fuses				
Prospective short-circuit (kA rms)	7	10	5	5
Associated fuse rating (A)	25	40	63	100
Rated operational voltage (V _{a.c.})	690	690	690	690
Connection				
Minimum CU cable cross-section (mm ²)	0.5	1	1.5	4
Maximum CU cable cross-section (mm ²)	4	10	16	35
Tightening torque min - max (Nm)	0.8-1.2	1.2-1.5	2.5	1.5
Mechanical characteristics				
Durability (number of operating cycles)	100 000	100 000	100 000	100 000
Weight of a 3 pole device (g)	109	184	440	440
Weight of a 4 pole device (g)	130	221	535	535

(1) The power is given for information only, the current values vary from one manufacturer to another.

Characteristics according to UL 60947-4-1

25 to 100 A

General use rating (A)	25 A	40 A	63 A	100 A
UL certification file	88EJ		5LM6	
Short circuit rating at 600 VAC (kA)	10	5	/	
Type of fuse	RK5		/	
Max fuse rating (A)	150		/	
Max horsepower rating (HP)				
120 VAC / 1 phase	-	2	/	
120 VAC / 3 phase	-	5	/	
240 VAC / 1 phase	-	3	/	
240 VAC / 3 phase	-	10	/	
480 VAC / 3 phase	-	20	/	
600 VAC / 3 phase	5.2	20	/	
Connection terminals				
Solid wire (AWG)	#14-#12	#14-#8	#14-#4	#10-#2
Wire stripping distance (in/mm)	0.31 / 8	0.39 / 10	0.51 / 13	0.51 / 13
Mechanical characteristics				
Durability (number of operating cycles)	100000	100000	100000	100000
Tightening torque (Lb.in / N.m)	8.8 / 1	13.3 / 1.5	22.1 / 2.5	13.3 / 1.5
Weight of a 3 pole device (lb)	0.24	0.4	1	1
Weight of a 4 pole device (lb)	0.28	0.49	1.18	1.18

Dimensions (in/mm)

25 to 100A

Mounting on door - Fixing with direct handle

Door width		
Unit	Mini	Maxi
in	0.04	0.16
mm	1	4

Rating (A)	Unit	I-II / I-0-II		L		Bypass I-0-II		C	D
		3 P	4 P	3 P	4 P				
25	in	3.19	3.66	4.13	4.61	1.54	1.57		
	mm	81	93	105	117	39	40		
40	in	3.31	4.82	4.33	4.84	2.11	2.2		
	mm	84	97	110	123	53.6	56		
63 - 100	in	4.45	5.28	6.1	6.93	2.91	2.8		
	mm	113	134	155	176	74	71		

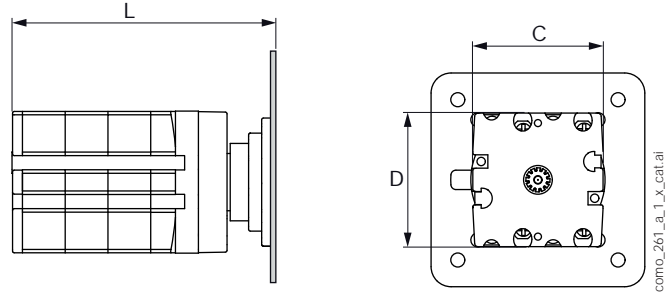

Mounting on backplate / DIN rail - Rear fixing of direct handle

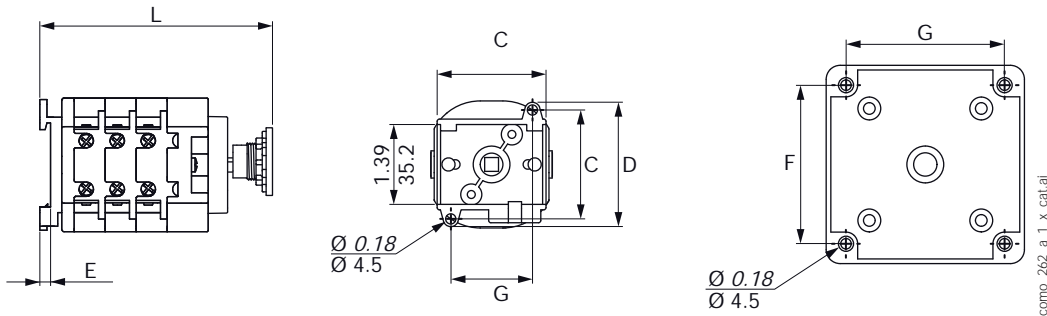

Rating (A)	Unit	I-II / I-0-II		L		E	C	D	F	G
		3 P	4 P	3 P	4 P					
25	in	3.20	3.68	4.15	4.57	0.18	1.89	2.2	1.65	1.42
	mm	81.4	93.4	105.4	116.1	4.5	48	56	47	36
40	in	3.73	4.28	4.28	5.08	0.18	1.89	2.2	1.65	1.42
	mm	94.7	107.7	120.7	129	4.5	48	56	47	36
63 ... 100	in	5.10	5.97	6.83	7.54	-	2.99	2.99	2.68	2.68
	mm	129.5	151.5	173.5	191.5	-	76	76	68	68

Mounting on backplate / DIN rail - Rear fixing of external handle

Rating (A)	Unit	X-L ⁽³⁾		E	B		
		I-II / I-0-II	Bypass I-0-II				
25	in	3.15	3.63	4.10	4.57	0.18	1.24
	mm	80.1	92.1	104.1	116.1	4.5	31.6
40	in	3.54	4.06	4.57	5.08	0.18	1.24
	mm	90	103	116	129	4.5	31.6
63 ... 100	in	5.06	5.89	6.71	7.54	-	1.24
	mm	128.5	149.5	170.5	191.5	-	31.6

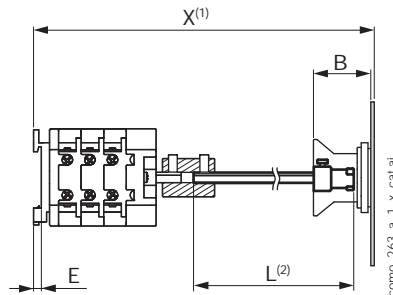

(1) X is the distance between the inside of the door and the fixing plate
 (2) L is the total length of the shaft (max 200 mm)
 (3) Minimum distance between the inside of the door and the fixing plate

Dimensions for handles

25 to 100 A

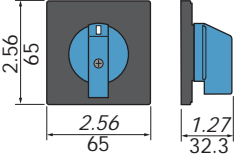
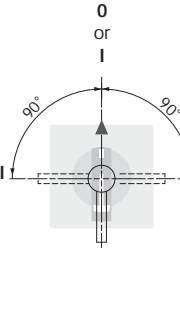
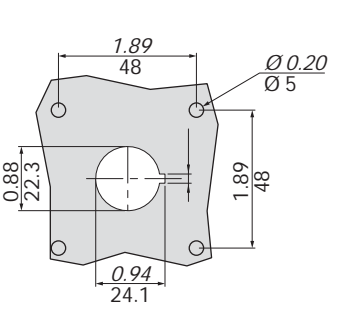
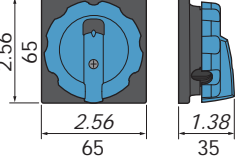
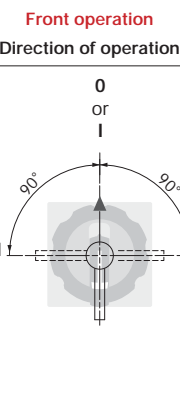
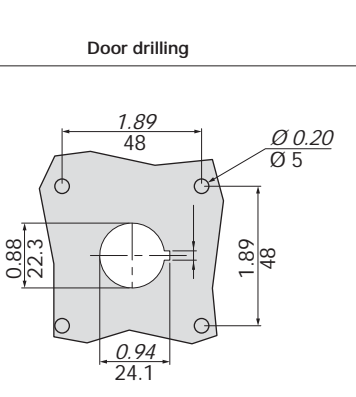
Handle type	Front operation Direction of operation	Door drilling
<p>K1 type non padlockable</p> 	<p>0 or I</p> 	 <p style="text-align: right; font-size: small;">polign_075_a_1_gb_cat.ai</p>
<p>K1 type padlockable</p> 	<p>0 or I</p> 	 <p style="text-align: right; font-size: small;">polign_076_a_1_gb_cat.ai</p>

SIRCOVER

Manual Transfer Switching Equipment
from 125 to 3200 A

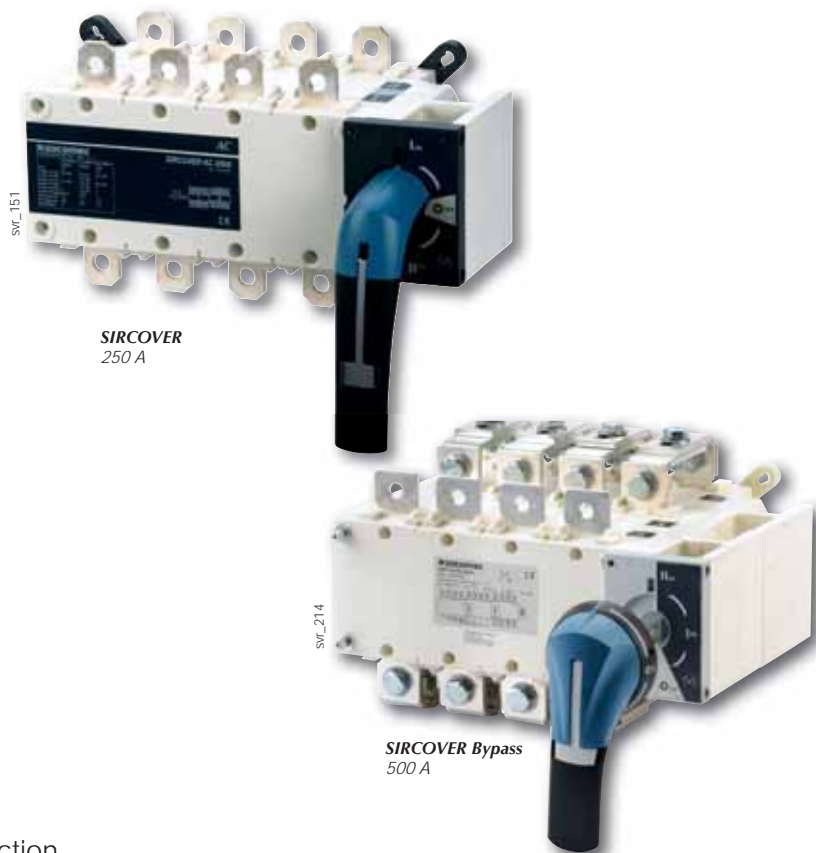

The solution for

- > Manufacturing
- > Power distribution



Strong points

- > Complete range
- > Easy to connect
- > Stable positions
- > On-load switching

Conformity to standards

- > IEC 60947-6,-1
- > IEC 60947-3
- > GB/T 14048-11



Approvals and certifications⁽¹⁾



BUREAU
VERITAS

⁽¹⁾ Product references on request.

SIRCOVER in enclosure



See "Enclosed transfer switches".

Function

SIRCOVER products are manually operated transfer switches with positive break indication. There are 4 ranges in the series:

- **SIRCOVER** for open transition switching (I-0-II) available in 3 or 4 pole.
- **SIRCOVER** for overlapping contact switching (I-I+II-II). For applications where both sources are synchronised and there is to be no interruption to the load supply during transfer - available in 3 or 4 pole.
- **SIRCOVER Bypass**. This combination of three interlocked load break switches provides 3+6 or 4+8 poles for bypass applications.
- **SIRCOVER Bypass** for overlapping contact switching (I-I+II-II). This combination of three interlocked load break switches provides bypass to an UPS or other devices when sources are synchronised and the UPS is in static bypass mode.

They provide on-load transfer between two sources for any low voltage power circuit, as well as safety isolation by double breaking per pole. Other applications include source inversion (e.g. to change the direction of a motor) or grounding/earthing.

Advantages

A complete range

There are 4 SIRCOVER models to meet every need: The standard model I-0-II, the overlapping contact model I-I+II-II, the bypass model and the bypass with overlapping contact model I-I+II-II.

Easy to connect

For ratings of 2000 to 3200 A, we offer copper bar connection pieces. This gives you the option of different connection methods - flat, edgewise with top or bottom bridging.

Stable positions

SIRCOVER devices have three stable positions, unaffected by voltage fluctuations and vibrations, protecting your loads from network disturbances.

On-load switching

With its AC-23 and AC-33 characteristics, tested according to standards IEC 60947-3 and IEC 60947-6-1, the SIRCOVER enables safe on-load switching for any type of load. With its on-load transfer capabilities, it is not necessary to isolate loads prior to transfer therefore the SIRCOVER offers an economical solution.

What you need to know

- SIRCOVER with **break-before-make contacts (I-0-II)** are available as 3 or 4 pole models with ratings of 125 to 3200 A. They are available in steel or polyester enclosures (125 to 1600 A).
- SIRCOVER switches with **3 overlapping contact positions (I-I+II-II)** are available as 3 or 4 pole models from 125 to 1600 A. They are available in steel enclosures.
- With **break-before-make (I-0-II)** or overlapping contact positions (I-I+II-II), SIRCOVER Bypass devices are a combination of three interlocked switches enabling the use with 3+6 or 4+8 poles from 125 to 1600 A. They are available in steel enclosures.
- All SIRCOVER can be operated with **direct front operation** or **external handles**.

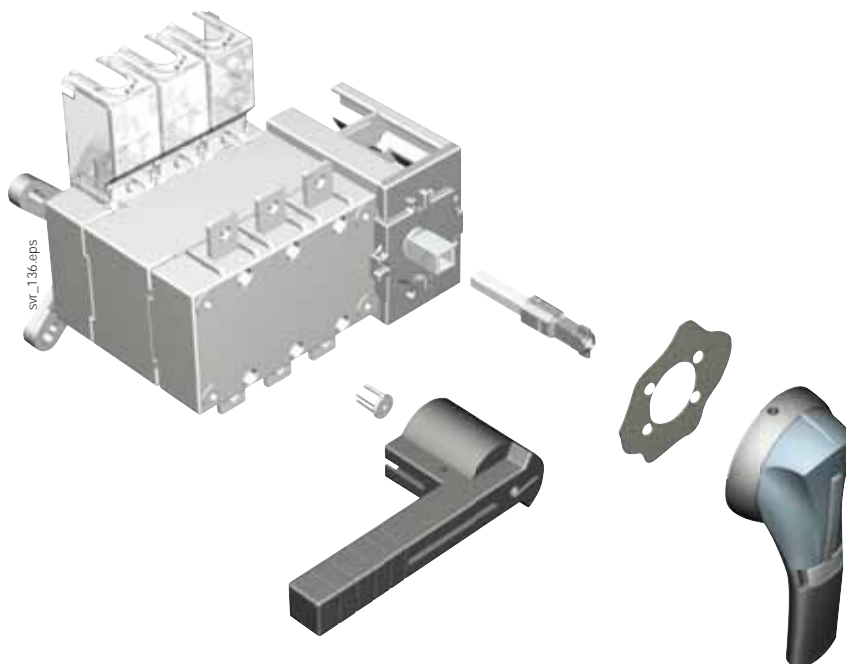

- **Connection pieces for copper bars** allows the connection between the 2 power terminals of the same pole (Fig. 1 and 2) and the bridging of switch I and switch II on the top or the bottom for ratings 2000, 2500 and 3200 A (Fig. 3).

Fig. 1

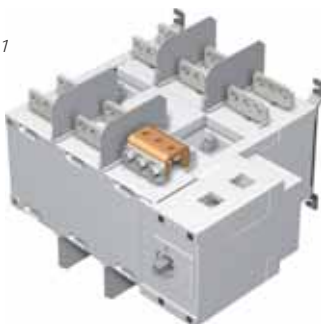

access_462_a

Top or bottom
flat connection

Fig. 2

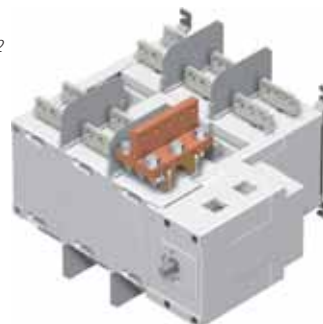

access_463_a

Top or bottom
edgewise connection

Fig. 3

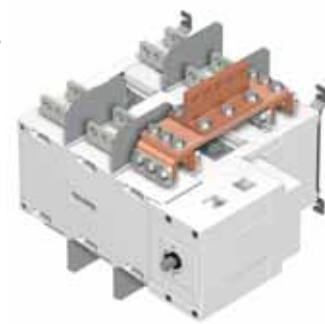

access_231_a_1_cat

Top or bottom
bridging connection

SIRCOVER

Manual Transfer Switching Equipment
from 125 to 3200 A

References

SIRCOVER I-0-II

Rating(A) / Frame size	No. of poles	Switch body	Direct handle	External handle	Shaft for external handle	Bridging bars ⁽⁶⁾	Auxiliary contact	Terminal shrouds	Terminal screens			
125 A / B3	3 P	41AC 3013	J2 type Blue 1122 1111 Red 1123 1111	S2 type Black IP55 1421 2113 IP65 1423 2113 ⁽¹⁾	200 mm 1400 1020	4109 0019	1 st /2 nd NO/NC contact 4109 0021 ⁽²⁾	3 P 2694 3014 ⁽³⁾⁽⁴⁾ 4 P 2694 4014 ⁽³⁾⁽⁴⁾	3 P 1509 3012 4 P 1509 4012			
	160 A / B3	3 P								41AC 3016		
4 P		41AC 4016										
200 A / B3	3 P	41AC 3020										
	4 P	41AC 4020										
250 A / B4	3 P	41AC 3025										
	4 P	41AC 4025										
315 A / B4	3 P	41AC 3031				320 mm 1400 1032 ⁽¹⁾		4109 0039	3 P 2694 3021 ⁽³⁾⁽⁴⁾ 4 P 2694 4021 ⁽³⁾⁽⁴⁾	3 P 1509 3025 4 P 1509 4025		
	400 A / B4	3 P									41AC 3040	
4 P		41AC 4040										
500 A / B5	3 P	41AC 3050										
	4 P	41AC 4050										
630 A / B5	3 P	41AC 3063	200 mm 1401 1520	4109 0120	3 P 2694 3051 ⁽³⁾⁽⁴⁾ 4 P 2694 4051 ⁽³⁾⁽⁴⁾		3 P 1509 3063 4 P 1509 4063					
	800 A / B6	3 P				41AC 3080						
4 P		41AC 4080										
1000 A / B6	3 P	41AC 3100				J3 type Black 1132 1111		S4 type Black IP65 1443 3113	320 mm 1401 1532 ⁽¹⁾	4109 0080	3 P 1509 3080 4 P 1509 4080	
	1250 A / B6	3 P										41AC 3120
4 P		41AC 4120										
1600 A / B7	3 P	41AC 3160	S5 type Black 2799 7042	S5 type Black IP65 1453 8113	200 mm 2799 3015		4109 0160					1509 3160 1509 4160
	2000 A / B8	3 P										
4 P		41AC 4200										
2500 A / B8	3 P	41AC 3250				450 mm 2799 3018 ⁽¹⁾		4109 0120	320 mm 2799 3018 ⁽¹⁾	4109 0160	1509 3160 1509 4160	
	3200 A / B8	3 P										
4 P		41AC 4320										

(1) Standard.

(2) 2 contacts supplied: one for position I and one for position II.

(3) For complete shrouding at front, rear, top and bottom, order quantity 4; if equipped with bridging bars order quantity 3.

(4) For top and bottom shrouding for the front only, order quantity 2.

(5) See "Copper bar connection pieces".

(6) For a 3 pole device order quantity 3 bridging bars, for a 4 pole device order quantity 4.

Operating principle

SIRCOVER I-0-II

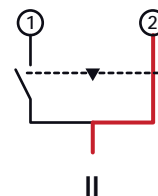
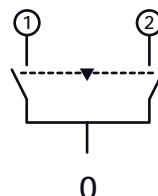
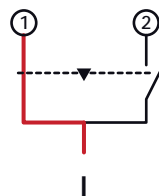
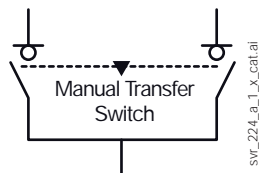

sw_225_a_1_x_catal

SIRCOVER I-I+II-II

Rating (A) / Frame size	No. of poles	Switch body	Direct handle	External handle	Shaft for external handle	Bridging bars ⁽⁶⁾	Auxiliary contact	Terminal shrouds	Terminal screens
125 A / B3	3 P	4190 3013	J2 type Blue 1122 1111 Red 1123 1111	S2 type Blue IP65 1423 2114	200 mm 1400 1020	3 P 4109 3019 4 P 4109 4019	1 st /2 nd NO/NC contact 4109 0021 ⁽²⁾	3 P 2694 3014 ⁽³⁾⁽⁴⁾ 4 P 2694 4014 ⁽³⁾⁽⁴⁾	3 P 1509 3012 4 P 1509 4012
	160 A / B3	4 P							
3 P		4190 3016							
200 A / B3	4 P	4190 4016							
	3 P	4190 3019							
250 A / B4	4 P	4190 4019							
	3 P	4190 3025							
400 A / B4	4 P	4190 4025							
	3 P	4190 3039							
630 A / B5	4 P	4190 4039							
	3 P	4190 3063							
800 A / B6	4 P	4190 4063							
	3 P	4190 3080							
1250 A / B6	4 P	4190 4080							
	3 P	4190 3120							
1600 A / B7	4 P	4190 4120							
	3 P	4190 3160							
	4 P	4190 4160							
	3 P	4190 3160							
	4 P	4190 4160							

(1) Standard.
 (2) 2 contacts supplied: one for position I and one for position II.
 (3) For complete shrouding at front, rear, top and bottom, order quantity 4; if equipped with bridging bars order quantity 3.
 (4) For top and bottom shrouding for the front only, order quantity 2.
 (5) See "Copper bar connection pieces".
 (6) For a 3 pole device order quantity 3 bridging bars, for a 4 pole device order quantity 4.

Operating principle

SIRCOVER I-I+II-II

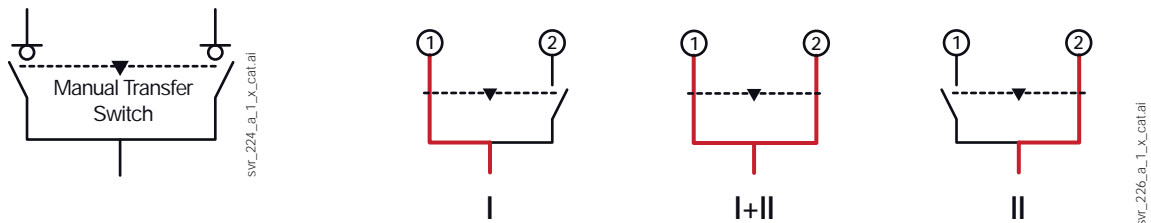

Warning: Please note that in position I+II contacts overlap.
 In case of UPS, make sure it is working in static bypass mode before operating.

SIRCOVER

Manual Transfer Switching Equipment
from 125 to 3200 A

References (continued)

SIRCOVER Bypass I-0-II

Rating (A) / Frame size	No. of poles	Switch body	Direct handle	External handle	Shaft for external handle	Bridging bars ⁽⁶⁾	Auxiliary contact	Terminal shrouds	Terminal screens
125 A / B3	3 P	41AC 7013	J2 type Blue 1122 1111	S2 type Blue IP55 1421 2113	200 mm 1400 1020	3 P 2x 4109 3019		3 P 2694 3014 ⁽³⁾⁽⁴⁾	3 P 1509 3012
	4 P	41AC 9013							
160 A / B3	3 P	41AC 7016	Red 1123 1111	Blue IP65 1423 2113 ⁽¹⁾	320 mm 1400 1032 ⁽¹⁾	4 P 2x 4109 4019		3 P 2694 3014 ⁽³⁾⁽⁴⁾	3 P 1509 3012
	4 P	41AC 9016							
200 A / B3	3 P	41AC 7020						3 P 2694 3014 ⁽³⁾⁽⁴⁾	3 P 1509 3012
	4 P	41AC 9020							
250 A / B4	3 P	41AC 7025	J3 type Black 1132 1111	S3 type Blue IP65 1433 3113	200 mm 1401 1520	2x 4109 3025	1 st /2 nd NO/NC contact 4109 0021 ⁽²⁾	3 P 2694 3021 ⁽³⁾⁽⁴⁾	3 P 1509 3025
	4 P	41AC 9025							
400 A / B4	3 P	41AC 7040			320 mm 1401 1532 ⁽¹⁾	2x 4109 3039		3 P 2694 3021 ⁽³⁾⁽⁴⁾	3 P 1509 3025
	4 P	41AC 9040							
630 A / B5	3 P	41AC 7063				2x 4109 3063		3 P 2694 3051 ⁽³⁾⁽⁴⁾	3 P 1509 3063
	4 P	41AC 9063							
800 A / B6	3 P	41AC 7080	J4 type Black 1142 1111 ⁽⁵⁾	V2 type Black IP65 4199 7146	200 mm 2799 3015	2x 4109 3080		3 P 2694 3051 ⁽³⁾⁽⁴⁾	3 P 1509 3080
	4 P	41AC 9080							
1250 A / B6	3 P	41AC 7120			320 mm 2799 3018 ⁽¹⁾	2x 4109 3120		3 P 2694 3051 ⁽³⁾⁽⁴⁾	3 P 1509 3080
	4 P	41AC 9120							
1600 A / B7	3 P	41AC 7160			450 mm 2799 3019	2x 4109 3160		3 P 2694 3051 ⁽³⁾⁽⁴⁾	3 P 1509 3160
	4 P	41AC 9160							

(1) Standard.

(2) 2 contacts supplied: one for position I and one for position II.

(3) For complete shrouding at front, rear, top and bottom, order quantity 6; if equipped with bridging bars order quantity 4.

(4) For top and bottom shrouding for the front only, order quantity 2.

(5) Double lever handle.

(6) For a 3 pole device order quantity 6 bridging bars, for a 4 pole device order quantity 8.

Operating principle

SIRCOVER Bypass I-0-II

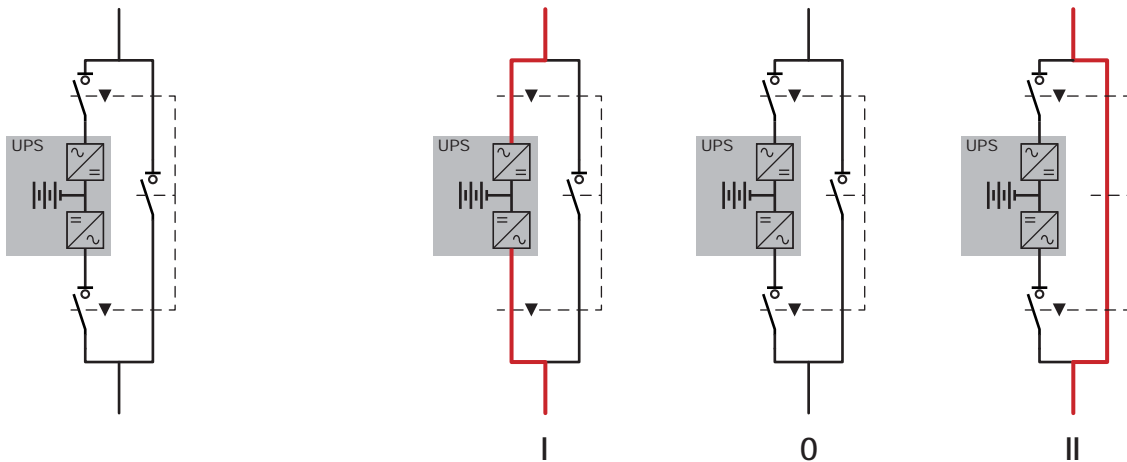

svr_227_a_1_x_cat.ai

SIRCOVER Bypass I-I+II-II

Rating (A) / Frame size	No. of poles	Switch body	Direct handle	External handle	Shaft for external handle	Bridging bars ⁽⁶⁾	Auxiliary contact	Terminal shrouds	Terminal screens
125 A / B3	3 P	46AC 7013	J2 type Blue 1122 1111	S2 type Blue IP 65 1423 2114 ⁽¹⁾	200 mm 1400 1020	3 P 2x 4109 3019	1 st /2 nd NO/NC contact 4109 0021 ⁽²⁾	3 P 2694 3014 ⁽³⁾⁽⁴⁾	3 P 1509 3012
	4 P	46AC 9013							
160 A / B3	3 P	46AC 7016	Red 1123 1111	S3 type Blue IP65 1433 3114	320 mm 1400 1032 ⁽¹⁾	4 P 2x 4109 4019		4 P 2694 4021 ⁽³⁾⁽⁴⁾	4 P 1509 4025
	4 P	46AC 9016							
200 A / B3	3 P	46AC 7020	J3 type Black 1132 1111	S3 type Blue IP65 1433 3114	320 mm 1401 1532 ⁽¹⁾	2x 4109 3025		4 P 2694 4021 ⁽³⁾⁽⁴⁾	4 P 1509 4025
	4 P	46AC 9020							
250 A / B4	3 P	46AC 7025	J3 type Black 1132 1111	S3 type Blue IP65 1433 3114	200 mm 1401 1520	2x 4109 4025		4 P 2694 4021 ⁽³⁾⁽⁴⁾	4 P 1509 4025
	4 P	46AC 9025							
400 A / B4	3 P	46AC 7040	J3 type Black 1132 1111	S3 type Blue IP65 1433 3114	320 mm 1401 1532 ⁽¹⁾	2x 4109 3039		4 P 2694 4021 ⁽³⁾⁽⁴⁾	4 P 1509 4025
	4 P	46AC 9040							
630 A / B5	3 P	46AC 7063	J3 type Black 1132 1111	S3 type Blue IP65 1433 3114	320 mm 1401 1532 ⁽¹⁾	2x 4109 4039		4 P 2694 4021 ⁽³⁾⁽⁴⁾	4 P 1509 4025
	4 P	46AC 9063							
800 A / B6	3 P	46AC 7080	J4 type Black 1142 1111 ⁽⁵⁾	V2 type Black IP65 4199 7146	200 mm 2799 3015	2x 4109 3063		4 P 2694 4051 ⁽³⁾⁽⁴⁾	4 P 1509 4063
	4 P	46AC 9080							
1250 A / B6	3 P	46AC 7120	J4 type Black 1142 1111 ⁽⁵⁾	V2 type Black IP65 4199 7146	320 mm 2799 3018 ⁽¹⁾	2x 4109 3080		4 P 2694 4051 ⁽³⁾⁽⁴⁾	4 P 1509 3080
	4 P	46AC 9120							
1600 A / B7	3 P	46AC 7160	J4 type Black 1142 1111 ⁽⁵⁾	V2 type Black IP65 4199 7146	450 mm 2799 3019	2x 4109 4080		4 P 2694 4051 ⁽³⁾⁽⁴⁾	4 P 1509 3160
	4 P	46AC 9160							

- (1) Standard.
- (2) 2 contacts supplied: one for position I and one for position II.
- (3) For complete shrouding at front, rear, top and bottom, order quantity 6; if equipped with bridging bars order quantity 4.
- (4) For top and bottom shrouding for the front only, order quantity 2.
- (5) Double lever handle.
- (6) For a 3 pole device order quantity 6 bridging bars, for a 4 pole device order quantity 8.

Operating principle

SIRCOVER Bypass I-I+II-II

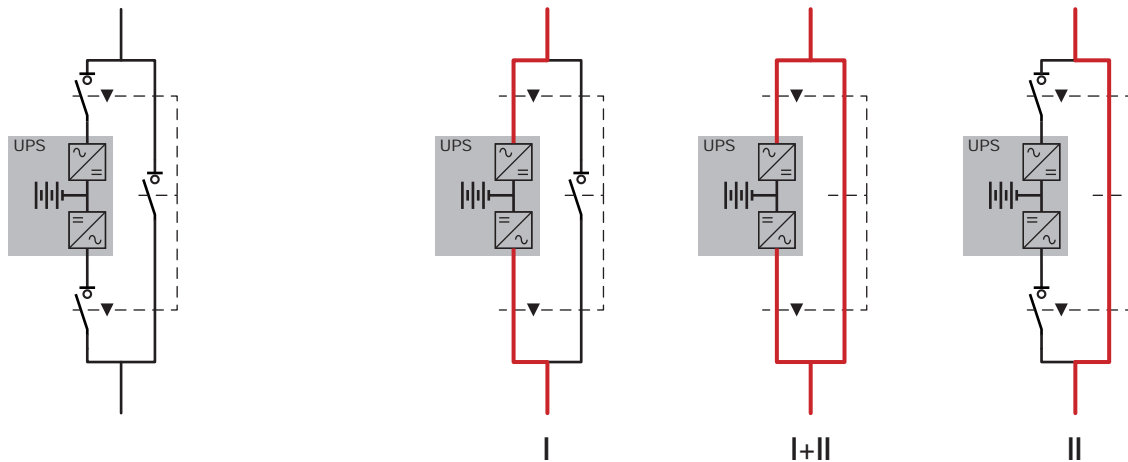

svr_228_a_1_x_cat.ai

Warning: Please note that in position I+II contacts overlap.
In case of UPS, make sure it is working in static bypass mode before operating.

SIRCOVER

Manual Transfer Switching Equipment
from 125 to 3200 A

Accessories

Direct operation handle

SIRCOVER I-0-II and I-I+II-II				
Rating (A)	Frame size	Handle colour	Handle type	Reference
125 ... 630	B3 ... B5	Blue	J2	1122 1111
125 ... 630	B3 ... B5	Red	J2	1123 1111
800 ... 1600	B6 ... B7	Blue	J3	1132 1111
2000 ... 3200	B8	Black	S5	2799 7042 ⁽¹⁾

SIRCOVER Bypass				
Rating (A)	Frame size	Handle colour	Handle type	Reference
125 ... 200	B3	Blue	J2	1122 1111
250 ... 630	B4 ... B5	Blue	J3	1132 1111
800 ... 1600	B6 ... B7	Blue	J4	1142 1111 ⁽¹⁾

(1) Double lever handle.



External operation handle

Use

Door interlocked external front operation handles include an escutcheon, are padlockable and must be utilised with an extension shaft.

SIRCOVER I-0-II and I-I+II-II					
Rating (A)	Frame size	Switching type	External IP ⁽¹⁾	Handle type	Reference
125 ... 630	B3 ... B5	I - 0 - II	IP55	S2	1421 2113
125 ... 630	B3 ... B5	I - 0 - II	IP65	S2	1423 2113
125 ... 630	B3 ... B5	I - I+II - II	IP65	S2	1423 2114
800 ... 1600	B6 ... B7	I - 0 - II	IP65	S4	1443 3113 ⁽²⁾
800 ... 1600	B6 ... B7	I - I+II - II	IP65	S4	1443 3114 ⁽²⁾
2000 ... 3200	B8	I - 0 - II	IP65	S5	1453 8113 ⁽²⁾

(1) IP: protection index according to IEC 60529.

(2) Double lever handle.

SIRCOVER Bypass					
Rating (A)	Frame size	Switching type	External IP ⁽¹⁾	Handle type	Reference
125 ... 200	B3	I - 0 - II	IP55	S2	1421 2113
125 ... 200	B3	I - 0 - II	IP65	S2	1423 2113
250 ... 630	B4 ... B5	I - 0 - II	IP65	S3	1433 3113
800 ... 1600	B6 ... B7	I - 0 - II	IP65	V2	4199 7146

(1) IP: protection index according to IEC 60529.



Alternative S type handle cover colours

Use

For single lever handles S2, S3 and for double lever handle S4.

Other colours available: consult us.

Colour	To be ordered in multiples of	Handle type	Reference
Light grey	50	S2, S3	1401 0001
Dark grey	50	S2, S3	1401 0011
Light grey	50	S4	1401 0031
Dark grey	50	S4	1401 0041



access_198.eps

S type handle adapter

Use

Enables S type handles to be fitted in place of existing older style SOCOMEC handles.

Adapter can also be utilised as a spacer to increase the distance between the panel door and the handle lever.

Dimensions

Add 12 mm to the handle depth.

Colour	To be ordered in multiples of	External IP ⁽¹⁾	Reference
Black	1	IP65	1493 0000

(1) IP: protection index according to IEC 60529.



access_187.eps

Shaft guide for external operation

Use

For use with S type handles, to guide the shaft extension into the external handle.

This accessory enables the handle to engage the extension shaft with a misalignment of up to 15 mm.

Recommended for a shaft length over 320 mm.

Designation	Reference
Shaft guide	1429 0000



access_260.eps

SIRCOVER

Manual Transfer Switching Equipment
from 125 to 3200 A

Accessories (continued)

Shaft for external operation

Use

Standard lengths:

- 200 mm,
- 320 mm,
- 450 mm.

Other lengths available: consult us.



access_269.eps



access_144.eps

SIRCOVER I-0-II and I-I+II-II				
Rating (A)	Frame size	Length (mm)	Side X (mm)	Reference
125 ... 400	B3 ... B4	200	210 ... 310	1400 1020
125 ... 400	B3 ... B4	320	210 ... 430	1400 1032
500 ... 630	B5	200	280 ... 390	1400 1020
500 ... 630	B5	320	280 ... 510	1400 1032
800 ... 1600	B6 ... B7	200	425 ... 577	1401 1520
800 ... 1600	B6 ... B7	320	425 ... 697	1401 1532
2000 ... 3200	B8	200	653 ... 803	2799 3015
2000 ... 3200	B8	320	653 ... 923	2799 3018
2000 ... 3200	B8	450	653 ... 1053	2799 3019

SIRCOVER Bypass				
Rating (A)	Frame size	Length (mm)	Side X (mm)	Reference
125 ... 200	B3	200	320 ... 450	1400 1020
125 ... 200	B3	320	320 ... 570	1400 1032
250 ... 400	B4	200	298 ... 420	1401 1520
250 ... 400	B4	320	298 ... 540	1401 1532
630	B5	200	417 ... 539	1401 1520
630	B5	320	417 ... 659	1401 1532
800 ... 1600	B6 ... B7	200	550 ... 680	2799 3015
800 ... 1600	B6 ... B7	320	550 ... 800	2799 3018
800 ... 1600	B6 ... B7	450	550 ... 930	2799 3019

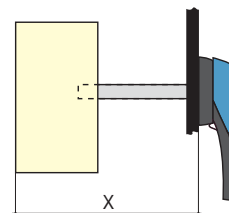

access_202_a_1_x_cat.eps

Bridging bars

Use

For creating a common connection between switches I & II, on the top or bottom side of the SIRCOVER, to enable, for example, the load to be fed from either incoming source (I or II).

For SIRCOVER Bypass, twice the quantity of bridging bars are required (6 for 3 pole device and 8 for 4 pole).

Rating (A)	Frame size	Diameter (mm)	Reference ⁽¹⁾
125 ... 200	B3	20 x 2.5	4109 0019
250	B4	25 x 2.5	4109 0025
315 ... 400	B4	32 x 5	4109 0039
500	B5	32 x 5	4109 0050
630	B5	50 x 5	4109 0063
800 ... 1000	B6	50 x 6	4109 0080
1250	B6	60 x 8	4109 0120
1600	B7	90 x 10	4109 0160

⁽¹⁾ SIRCOVER: For a 3 pole device order quantity 3 bridging bars, and for a 4 pole device order quantity 4.
SIRCOVER Bypass: For a 3 pole device order quantity 6 bridging bars, and for a 4 pole device order quantity 8.

SIRCOVER I-0-II and SIRCOVER I-I+II-II



access_205.eps

SIRCOVER Bypass



access_208.eps



access_041.eps

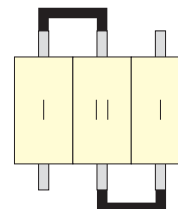

sw_066_a_1_x_cat.eps

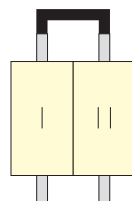

sw_124_b_1_cat.eps

Copper bar connection pieces

Use

For ratings 2000 to 3200 A.

Enables:

- Flat connection: the connection pieces provide a link between the two power terminals of the same pole (Fig. 1).
- Edgewise connection: the connection pieces provide a link between the two power terminals of the same pole and an edgewise bar connection terminal.
- Top or bottom bridging between two poles (Fig. 3).

Once installed, the power terminal is connection ready.

For 3200 A rating, connection pieces (part A) are supplied as standard. Bolt sets must be ordered separately.

Connection: the quantities given in the below table refer to the number of pieces required per pole, top or bottom.

Bridging connection: the quantities given refer to the number of pieces required to complete a single bridging connection between two poles.

	Reference	2000 – 2500 A			3200 A		
		Fig. 1	Fig. 2	Fig. 3	Fig. 1	Fig. 2	Fig. 3
		Connection		Bridging connection I - II	Connection		Bridging connection I - II
Connection - part A	2619 1200	1	1		2 ⁽²⁾	included	
Bolt kit 35 mm - part B	2699 1201	1 ⁽¹⁾		2 ⁽²⁾	1 ⁽¹⁾		2 ⁽²⁾
Bolt kit 45 mm - part B	2699 1200	1 ⁽¹⁾			1 ⁽¹⁾		
T + Bolt kit - part C	2629 1200		1	1		1	1
Bracket + Bolt kit - part D	2639 1200		1			1	
Bar + Bolt kit - part E	4109 0320			1			1

(1) Choose the bolt length according to the thickness of the bars being connected; if bar thickness is greater than 20 mm, 45 mm bolts are required.

(2) For bridging connections, quantity 2 pieces are required for creating the link between the two power terminals of the same pole for switch bodies I and II.

The quantities of the applicable pieces then need to be multiplied by the number of connection points (power terminals) in order to determine the total quantity required of each part.

Example: for a 4 pole 2500 A SIRCOVER with upstream edgewise connection (Fig. 2) and downstream bridging (Fig. 3), the following quantities will be required:

Part	Upstream edgewise quantity	Downstream bridging quantity	Total quantity
A	8	8	16
B	0	8	8
C	8	4	12
D	8	0	8
E	0	4	4

Fig. 1

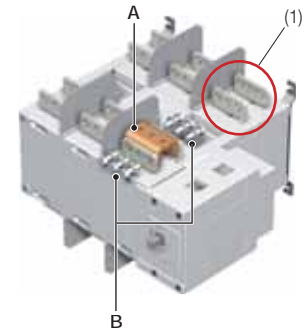

(1) Single pole connection: 1 pole (top or bottom) comprises two power terminals which are to be linked with the copper connection kit.

Fig. 2

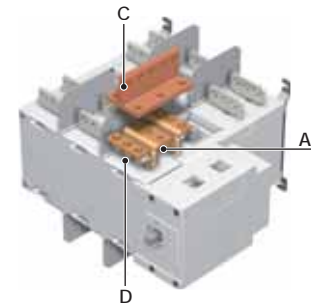
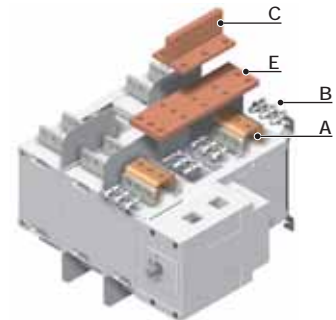

Fig. 3



Auxiliary contact

Use

Pre-breaking and signalling of positions I and II: 1 to 2 NO/NC auxiliary contacts in each position.

Low level AC: consult us.

Connection to the control circuit

By 6.35 mm fast-on terminal.

Electrical characteristics

30,000 operations.

Characteristics

Rating (A)	Frame size	Nominal current (A)	Operating current I _e (A)			
			250 VAC AC-13	400 VAC AC-13	24 VDC DC-13	48 VDC DC-13
125 ... 3200	B3... B8	16	12	8	14	6

NO/NC changeover contact			
Rating (A)	Frame size	Contact(s)	Reference
125 ... 1600	B3 ... B7	1 st / 2 nd	4109 0021
2000 ... 3200	B8	1 st / 2 nd	included



SIRCOVER

Manual Transfer Switching Equipment
from 125 to 3200 A

Accessories (continued)

Terminal shrouds

Use

Protection against direct contact with terminals or connecting parts.

Advantage

Perforations allow remote thermographic inspection without the need to remove the shrouds.

Rating (A)	Frame size	No. of poles	Position	Reference
125 ... 200	B3	3 P	top / bottom / front (I) / rear (II)	2694 3014 ⁽¹⁾⁽²⁾
125 ... 200	B3	4 P	top / bottom / front (I) / rear (II)	2694 4014 ⁽¹⁾⁽²⁾
250 ... 400	B4	3 P	top / bottom / front (I) / rear (II)	2694 3021 ⁽¹⁾⁽²⁾
250 ... 400	B4	4 P	top / bottom / front (I) / rear (II)	2694 4021 ⁽¹⁾⁽²⁾
500 ... 630	B5	3 P	top / bottom / front (I) / rear (II)	2694 3051 ⁽¹⁾⁽²⁾
500 ... 630	B5	4 P	top / bottom / front (I) / rear (II)	2694 4051 ⁽¹⁾⁽²⁾



access_206.psd

(1) For complete shrouding at front, rear, top and bottom, order 4 x for a SIRCOVER and 6 x for a SIRCOVER Bypass; if equipped with bridging bars order 3 x for a SIRCOVER and 4 x for a SIRCOVER Bypass.

(2) For top and bottom shrouding for the front only, order 2 x for a SIRCOVER and a SIRCOVER Bypass.

Terminal screens

Use

Upstream and downstream protection against direct contact with terminals or connection parts. For upstream and downstream protection, order quantity 1.

Rating (A)	Frame size	No. of poles	Position	Reference
125 ... 200	B3	3 P	top / bottom	1509 3012
125 ... 200	B3	4 P	top / bottom	1509 4012
250 ... 400	B4	3 P	top / bottom	1509 3025
250 ... 400	B4	4 P	top / bottom	1509 4025
500 ... 630	B5	3 P	top / bottom	1509 3063
500 ... 630	B5	4 P	top / bottom	1509 4063
800 ... 1250	B6	3 P	top / bottom	1509 3080
800 ... 1250	B6	4 P	top / bottom	1509 4080
1600	B7	3 P	top / bottom	1509 3160
1600	B7	4 P	top / bottom	1509 4160
2000 ... 3200	B8	3 / 4 P	top / bottom	included



access_207.eps

Inter-phase barrier

Use

Safe isolation between the terminals, essential for use at 690 VAC or in a polluted or dusty atmosphere.

Rating (A)	Frame size	No. of poles	Reference
125 ... 200	B3	3 P	2998 0033
125 ... 200	B3	4 P	2998 0034
250 ... 400	B4	3 P	2998 0023
250 ... 400	B4	4 P	2998 0024
500 ... 630	B5	3 P	2998 0013
500 ... 630	B5	4 P	2998 0014
800 ... 3200	B6 ... B8	3/4 P	included

Key handle interlocking system

Padlocking in position I, 0 or II				
SIRCOVER Rating (A) / Frame size	SIRCOVER Bypass Rating (A) / Frame size	Operation	Figure	Reference
125 ... 630 / B3 ... B5	125 ... 200 / B3	external	1	1423 2813

Locking using RONIS EL11AP lock in position 0 (not included)				
SIRCOVER Rating (A) / Frame size	SIRCOVER Bypass Rating (A) / Frame size	Operation	Figure	Reference
125 ... 630 / B3 ... B5	125 ... 200 / B3	direct	2	4109 1006 ⁽¹⁾
	250 ... 630 / B4 ... B5	direct	3	consult us
800 ... 1600 / B6 ... B7	800 ... 1600 / B6 ... B7	direct	3	4109 1004 ⁽²⁾
2000 ... 3200 / B8		direct	3	4109 2007 ⁽²⁾
125 ... 630 / B3 ... B5	125 ... 630 / B3 ... B5	external	4	1499 7701 ⁽²⁾
2000 ... 3200 / B8	800 ... 1600 / B6 ... B7	external	4	2799 7002 ⁽²⁾

(1) Specific handle included.

(2) This locking facility can be configured by the user in the 3 positions.

Locking using RONIS EL11AP lock in position I, 0, II (not included)				
SIRCOVER Rating (A) / Frame size	SIRCOVER Bypass Rating (A) / Frame size	Operation	Figure	Reference
125 ... 630 / B3 ... B5	125 ... 200 / B3	direct	2	4109 1002 ⁽¹⁾
	250 ... 630 / B4 ... B5	direct	3	consult us
800 ... 1600 / B6 ... B7	800 ... 1600 / B6 ... B7	direct	3	4109 1004 ⁽²⁾
2000 ... 3200 / B8		direct	3	4109 2007 ⁽²⁾
125 ... 630 / B3 ... B5	125 ... 630 / B3 ... B5	external	4	1499 7701 ⁽²⁾
2000 ... 3200	800 ... 1600 / B6 ... B7	external	4	2799 7002 ⁽²⁾

(1) Specific handle included.

(2) This locking facility can be configured by the user in the 3 positions.

Locking using 230 VAC undervoltage coil in position 0 (factory fitted)				
SIRCOVER Rating (A) / Frame size	SIRCOVER Bypass Rating (A) / Frame size	Operation	Figure	Reference
800 ... 3200 / B6 ... B8	800 ... 1600 / B6 ... B7	direct	3	consult us

Locking using Type K CASTELL lock (not supplied)				
SIRCOVER Rating (A) / Frame size	SIRCOVER Bypass Rating (A) / Frame size	Operation	Figure	Reference
125 ... 1600 / B3 ... B7	125 ... 630 / B3 ... B5	external	4	1499 7702
2000 ... 3200 / B8	800 ... 1600 / B6 ... B7	external	4	2799 7003

Use

- Padlocked (padlock not included). This device is factory mounted in the direct or external operation handle and allows the use of up to 3 padlocks.
- Locking:
 - using lock (not supplied),
 - using undervoltage coil.
- The interlocking positions are either determined as standard or configured by the user by removing the pre-form tabs.
- Padlocking and locking can be combined.

Fig. 1

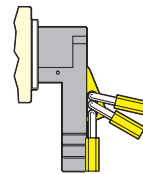
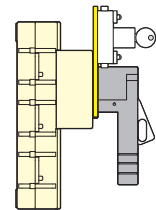

Fig. 2



access_061_a_1_x_cat

access_001_a_1_x_cat

Fig. 3



Fig. 4

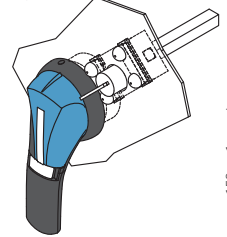

access_132_a_1_x_cat

access_158_a_1_x_cat

Other specific accessories



bc_03_04_01

- Customised protection screens (for specific dimensions or high ambient temperatures).
- Connection accessories.
- Low level auxiliary contacts.

Characteristics according to IEC 60947-3 and IEC 60947-6-1

125 to 630 A

Thermal current I th at 40°C	125 A	160 A	200 A	250 A	315 A	400 A	500 A	630 A
Frame size	B3	B3	B3	B4	B4	B4	B5	B5
Rated insulation voltage U _i (V)	800	800	800	1000	1000	1000	1000	1000
Rated impulse withstand voltage U _{imp} (kV)	8	8	8	12	12	12	12	12
Rated operational currents I _e (A) according to IEC 60947-6-1								
Rated voltage	Utilisation category	A/B ⁽¹⁾	A/B ⁽¹⁾	A/B ⁽¹⁾	A/B ⁽¹⁾	A/B ⁽¹⁾	A/B ⁽¹⁾	A/B ⁽¹⁾
415 VAC	AC-31 B	125	160	200	250	315	400	500
415 VAC	AC-32 B				200	315	400	500
415 VAC	AC-33 B				200	200	200	400
Rated operational currents I _e (A) according to IEC 60947-3								
Rated voltage	Utilisation category	A/B ⁽¹⁾	A/B ⁽¹⁾	A/B ⁽¹⁾	A/B ⁽¹⁾	A/B ⁽¹⁾	A/B ⁽¹⁾	A/B ⁽¹⁾
415 VAC	AC-21 A / AC-21 B	125/125	160/160	200/200	250/250	315/315	400/400	500/500
415 VAC	AC-22 A / AC-22 B	125/125	160/160	200/200	250/250	315/315	400/400	500/500
415 VAC	AC-23 A / AC-23 B	125/125	160/160	200/200	200/200	315/315	400/400	500/500
500 VAC	AC-21 A / AC-21 B	125/125	160/160	200/200	250/250	315/315	400/400	500/500
500 VAC	AC-22 A / AC-22 B	125/125	160/160	200/200	200/250	200/315	200/400	500/500
500 VAC	AC-23 A / AC-23 B	80/80	80/80	80/80	200/200	200/200	200/200	400/400
690 VAC ⁽³⁾	AC-21 A / AC-21 B	125/125	160/160	200/200	200/200	200/200	200/200	500/500
690 VAC ⁽³⁾	AC-22 A / AC-22 B	125/125	125/125	125/125	160/160	160/160	160/160	400/400
690 VAC ⁽³⁾	AC-23 A / AC-23 B	63/80	63/80	63/80	125/125	125/125	125/125	400/400
220 VDC	DC-21 A / DC-21 B	125/125	160/160	200/200	250/250	250/250	250/250	500/500
220 VDC	DC-22 A / DC-22 B	125/125	160/160	200/200	250/250	250/250	250/250	500/500
220 VDC	DC-23 A / DC-23 B	125/125	125/125	125/125	200/200	200/200	200/200	500/500
440 VDC ⁽²⁾	DC-21 A / DC-21 B	125/125	125/125	125/125	200/200	200/200	200/200	500/500
440 VDC ⁽²⁾	DC-22 A / DC-22 B	125/125	125/125	125/125	200/200	200/200	200/200	500/500
440 VDC ⁽²⁾	DC-23 A / DC-23 B	125/125	125/125	125/125	200/200	200/200	200/200	500/500
Operation power in AC-23 (kW) ⁽⁴⁾								
At 415 VAC without AC pre-break		58/58	75/75	100/100	100/100	145/145	190/190	235/235
At 690 VAC without AC pre-break		50/62	50/62	50/62	90/90	90/90	90/90	310/310
Reactive power (kvar) ⁽⁴⁾								
At 415 VAC (kvar)		60/60	75/75	100/100	125/125	150/150	200/200	250/250
Fuse protected short-circuit withstand as per IEC 60947-3 (kA rms prospective)								
Prospective short-circuit current with gG DIN fuses at 415 VAC (kA rms)		100	100	50	50	50	50	50
Prospective short-circuit current with gG DIN fuses at 690 VAC (kA rms)					50	50	50	50
Associated fuse rating (A)		125	160	200	250	315	400	500
Short-circuit withstand without protection as per IEC 60947-3								
Rated short-time withstand current 0.3s I _{cw} at 415 VAC (kA rms)		12	12	12	15 ⁽⁵⁾	15 ⁽⁵⁾	15 ⁽⁵⁾	17 ⁽⁵⁾
Rated short-time withstand current 1s I _{cw} at 415 VAC (kA rms)		7	7	7	8 ⁽⁵⁾	8 ⁽⁵⁾	8 ⁽⁵⁾	11 ⁽⁵⁾
Rated peak withstand current at 415 VAC (kA peak)		20	20	20	30	30	30	45
Short-circuit withstand without protection as per IEC 60947-6-1								
Rated short-time withstand current 30 ms I _{cw} at 415 VAC (kA rms)		10	10	10	10	10	10	
Rated short-time withstand current 60 ms I _{cw} at 415 VAC (kA rms)								10
Connection								
Minimum Cu cable cross-section as per IEC 60947-1 (mm ²)		35	35	50	95	120	185	2 x 95
Recommended Cu busbar cross-section (mm ²)								2 x 32 x 5
Maximum Cu cable cross-section (mm ²)		50	95	120	150	240	240	2 x 185
Maximum Cu busbar width (mm)		25	25	25	32	32	32	50
Min./max. tightening torque (Nm)		9/13	9/13	9/13	20/26	20/26	20/26	20/26
Mechanical specifications								
Durability (number of operating cycles)		10,000	10,000	10,000	8,000	8,000	8,000	5,000
Weight 3 P (kg)		2.9	2.9	2.9	3.8	3.9	3.9	8.6
Weight 4 P (kg)		4.1	4.1	4.1	4.6	4.9	4.9	11.1

(1) Category with index A = frequent operation - Category with index B = infrequent operation.

(2) 3-pole device with 2 pole in series for the "+" an 1 pole for the "-".

4-pole device with 2 poles in series by polarity.

(3) Interphase barriers must be installed on the products.

(4) The power value is given for information only, the current values vary from one manufacturer to another.

(5) Values given at 690 VAC.

800 to 3200 A

Thermal current I th at 40°C	800 A	1000 A	1250 A	1600 A	2000 A	2500 A	3200 A
Frame size	B6	B6	B6	B7	B8	B8	B8
Rated insulation voltage U _i (V)	1000	1000	1000	1000	1000	1000	1000
Rated impulse withstand voltage U _{imp} (kV)	12	12	12	12	12	12	12

Rated operational currents I_e (A) according to IEC 60947-6-1

Rated voltage	Utilisation category	A/B ⁽¹⁾	A/B ⁽¹⁾	A/B ⁽¹⁾	A/B ⁽¹⁾	A/B ⁽¹⁾	A/B ⁽¹⁾	A/B ⁽¹⁾
415 VAC	AC-31 B	800	1000	1250	1600	2000	2500	3200
415 VAC	AC-32 B	800	1000	1250	1250	2000	2000	2000
415 VAC	AC-33 B	800	1000	1000	1000	1250	1250	1250

Rated operational currents I_e (A) according to IEC 60947-3

Rated voltage	Utilisation category	A/B ⁽¹⁾	A/B ⁽¹⁾	A/B ⁽¹⁾	A/B ⁽¹⁾	A/B ⁽¹⁾	A/B ⁽¹⁾	A/B ⁽¹⁾
415 VAC	AC-21 A / AC-21 B	800/800	1000/1000	1250/1250	1600/1600	-/2000	-/2500	-/3200
415 VAC	AC-22 A / AC-22 B	800/800	1000/1000	1250/1250	1600/1600	-/2000	-/2500	-/3200
415 VAC	AC-23 A / AC-23 B	800/800	1000/1000	1250/1250	1250/1250	-/1600	-/1600	-/1600
500 VAC	AC-21 A / AC-21 B	800/800	1000/1000	1250/1250	1600/1600	-/2000	-/2000	-/2000
500 VAC	AC-22 A / AC-22 B	630/630	800/800	1000/1000	1600/1600			
500 VAC	AC-23 A / AC-23 B	630/630	800/800	800/800	1000/1000			
690 VAC ⁽³⁾	AC-21 A / AC-21 B	800/800	1000/1000	1250/1250	1600/1600	-/2000	-/2000	-/2000
690 VAC ⁽³⁾	AC-22 A / AC-22 B	630/630	800/800	1000/1000	1000/1000			
690 VAC ⁽³⁾	AC-23 A / AC-23 B	630/630	630/630	800/800	800/800			
220 VDC	DC-21 A / DC-21 B	800/800	1000/1000	1250/1250	1250/1250			
220 VDC	DC-22 A / DC-22 B	800/800	1000/1000	1250/1250	1250/1250			
220 VDC	DC-23 A / DC-23 B	800/800	1000/1000	1250/1250	1250/1250			
440 VDC ⁽²⁾	DC-21 A / DC-21 B	800/800	1000/1000	1250/1250	1250/1250			
440 VDC ⁽²⁾	DC-22 A / DC-22 B	800/800	1000/1000	1250/1250	1250/1250			
440 VDC ⁽²⁾	DC-23 A / DC-23 B	800/800	1000/1000	1250/1250	1250/1250			

Operation power in AC-23 (kW)⁽⁴⁾

At 415 VAC without AC pre-break	375/375	450/450	560/560	560/560	-/710	-/710	-/710
At 690 VAC without AC pre-break	475/475	475/475	620/620	620/620			

Reactive power (kvar)⁽⁴⁾

At 415 VAC (kvar)	400/400	500/500	650/650	650/650	-/850	-/850	-/850
-------------------	---------	---------	---------	---------	-------	-------	-------

Fuse protected short-circuit withstand as per IEC 60947-3 (kA rms prospective)

Prospective short-circuit current with gG DIN fuses at 415 VAC (kA rms)	50	50	100	100			
Prospective short-circuit current with gG DIN fuses at 690 VAC (kA rms)	50	50	50				
Associated fuse rating (A)	800	1000	1250	2x800			

Short-circuit withstand without protection as per IEC 60947-3

Rated short-time withstand current 0.3s I _{cw} at 415 VAC (kA rms)	64	64	64	78	78	78	78
Rated short-time withstand current 1s I _{cw} at 415 VAC (kA rms)	35	35	35	50	50	50	50
Rated peak withstand current at 415 VAC (kA peak)	55	55	80	110	120	120	120

Short-circuit withstand without protection as per IEC 60947-6-1

Rated short-time withstand current 30 ms I _{cw} at 415 VAC (kA rms)							
Rated short-time withstand current 60 ms I _{cw} at 415 VAC (kA rms)	20	20	25	32	50	50	50

Connection

Minimum Cu cable cross-section as per IEC 60947-1 (mm ²)	2 x 185						
Recommended Cu busbar cross-section (mm ²)	2 x 50 x 5	2 x 63 x 5	2 x 60 x 7	2 x 100 x 5	3 x 100 x 5	2 x 100 x 10	3 x 10 x 100
Maximum Cu cable cross-section (mm ²)	4 x 185	4 x 185	4 x 185	6 x 185			
Maximum Cu busbar width (mm)	63	63	63	100	100	100	100
Min./max. tightening torque (Nm)	20/26	20/26	20/26	40/45	40/45	40/45	40/45

Mechanical specifications

Durability (number of operating cycles)	4,000	4,000	4,000	3,000	3,000	3,000	3,000
Weight 3 P (kg)	20.5	21.0	21.6	25.7	42.0	42.0	52.3
Weight 4 P (kg)	24.8	25.6	26.2	32.0	52.9	52.9	66.6

(1) Category with index A = frequent operation - Category with index B = infrequent operation.

(2) 3-pole device with 2 pole in series for the "+" an 1 pole for the "-".

4-pole device with 2 poles in series by polarity.

(3) Interphase barriers must be installed on the products.

(4) The power value is given for information only, the current values vary from one manufacturer to another.

(5) Values given at 690 VAC.

SIRCOVER

Manual Transfer Switching Equipment
from 125 to 3200 A

Dimensions

SIRCOVER 125 to 1600 A / B3 to B7

Direct front operation

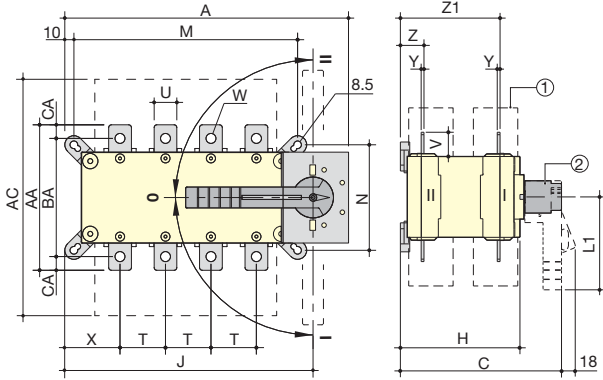

External front operation

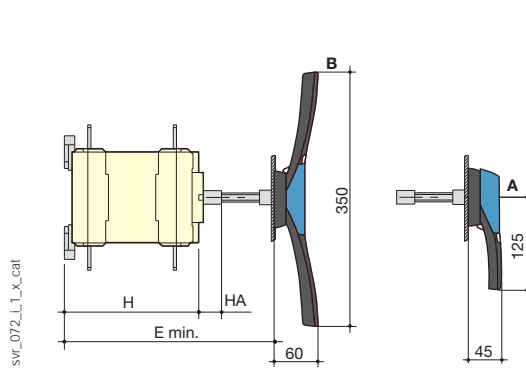

A. S2 type handle for external operation: 125 to 630 A
B. S4 type handle for external operation: 800 to 1600 A

1. Terminal shrouds
2. Direct operation handle:
 - 125 to 630 A: L1 = 140 mm,
 - 800 to 1600 A: L1 = 210 mm.

Rating (A)/ Frame size	Overall dimensions				Terminal shrouds	Switch body				Switch mounting				Connection										
	A 3p.	A 4p.	C	E min		AC	H	HA	J 3p.	J 4p.	M 3p.	M 4p.	N	T	U	V	W	X 3p.	X 4p.	Y	Z	Z1	AA	BA
125 / B3	221	251	218	208 ... 436	235	148	25	182	212	156	186	101	36	20	25	8.5	56	50	3.5	28	124	135	115	10
160 / B3	221	251	218	208 ... 436	235	148	25	182	212	156	186	101	36	20	25	8.5	56	50	3.5	28	124	135	115	10
200 / B3	221	251	218	208 ... 436	235	148	25	182	212	156	186	101	36	20	25	8.5	56	50	3.5	28	124	135	115	10
250 / B4	262	312	218	208 ... 436	280	148	25	223	273	196	246	116	50	25	30	11	61	61	3.5	30	124	160	130	15
315 / B4	262	312	218	208 ... 436	280	148	25	223	273	196	246	116	50	35	35	11	61	61	3.5	30	124	170	140	15
400 / B4	262	312	218	208 ... 436	280	148	25	223	273	196	246	116	50	35	35	11	61	61	3.5	30	124	170	140	15
500 / B5	319	379	295	285 ... 513	401	225	25	272	332	246	306	176	65	32	37	13	70.5	65.5	5	43	180	235	205	15
630 / B5	319	379	295	285 ... 513	400	225	25	272	332	246	306	176	65	45	50	13	70.5	65.5	5	43	180	260	220	20
800 / B6	386	466	375	425 ... 577	459	298	29	306.5	386.5	255	336	250	80	50	60.5	15	48	48	7	66.5	253.5	321		26.5
1000 / B6	386	466	375	425 ... 577	459	298	29	306.5	386.5	255	336	250	80	50	60.5	15	48	48	7	66.5	253.5	321		26.5
1250 / B6	386	466	375	425 ... 577	459	298	29	306.5	386.5	255	336	250	80	60	65	16x11	48	48	7	66.5	255.5	330		29.5
1600/B7	478	598	375	425 ... 577	461	298	29	388.5	518.5	347	467	250	120	90	43.5	12.5x5	54	54	8	66.5	255.5	288		15

SIRCOVER 2000 to 3200 A / B8

Direct front operation

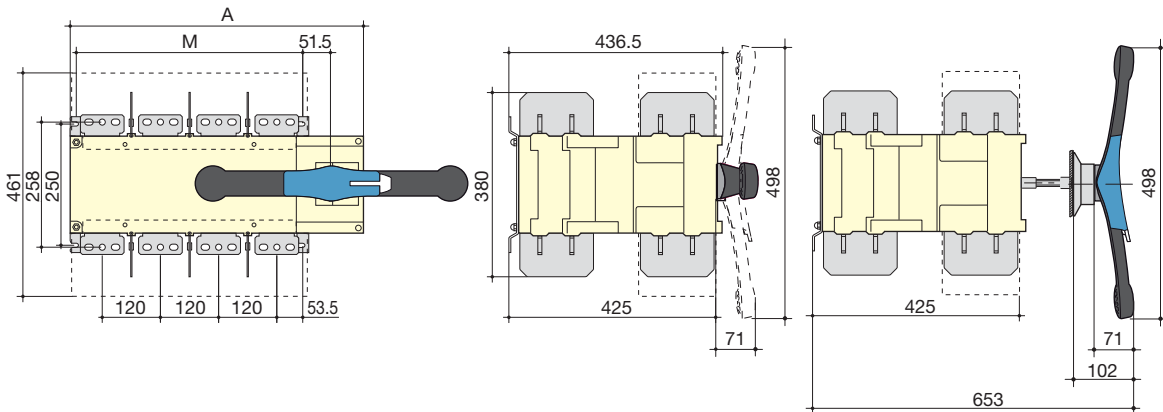

Rating (A) / Frame size	Overall dimensions		Switch mounting	
	A 3p.	A 4p.	M 3p.	M 4p.
2000 ... 3200 / B8	478	598	347	467

SIRCOVER Bypass 125 to 1600 A / B3 to B7

Direct front operation

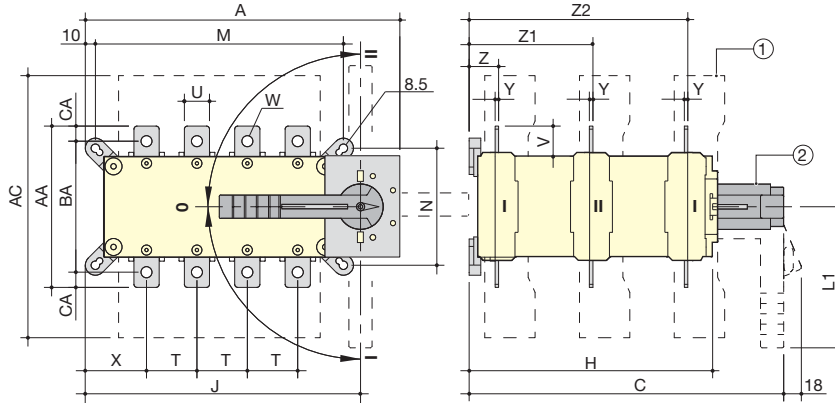

External front operation

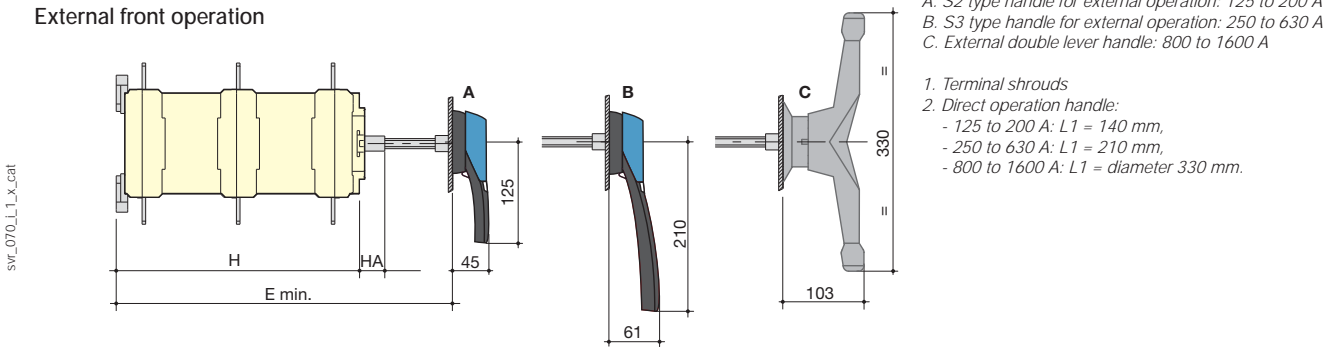

A. S2 type handle for external operation: 125 to 200 A
B. S3 type handle for external operation: 250 to 630 A
C. External double lever handle: 800 to 1600 A

1. Terminal shrouds
2. Direct operation handle:
 - 125 to 200 A: L1 = 140 mm,
 - 250 to 630 A: L1 = 210 mm,
 - 800 to 1600 A: L1 = diameter 330 mm.

Rating (A) / Frame size	Overall dimensions				Terminal shrouds	Switch body				Switch mounting				Connection											
	A 3+6p.	A 4+8p.	C	E min.		H	HA	J 3+6p.	J 4+8p.	M 3+6p.	M 4+8p.	N	T	U	V	W	X 3+6p.	X 4+8p.	Y	Z	Z1	Z2	AA	BA	AC
125 / B3	221	251	313	320	235	243	25	182	212	156	186	101	36	20	25	8.5	56	50	3.5	28	124	219	135	115	10
160 / B3	221	251	313	320	235	243	25	182	212	156	186	101	36	20	25	8.5	56	50	3.5	28	124	219	135	115	10
200 / B3	221	251	313	320	235	243	25	182	212	156	186	101	36	20	25	8.5	56	50	3.5	28	124	219	135	115	10
250 / B4	262	312	313	298	280	243	25	223	273	196	246	116	50	25	30	11	61	61	3.5	30	124	219	160	130	10
400 / B4	262	312	313	298	280	243	25	223	273	196	246	116	50	35	35	11	61	61	3.5	30	124	219	170	140	15
630 / B5	319	379	432	417	400	362	25	272	332	246	306	176	65	45	50	13	70.5	65.5	5	43	180	317	260	220	20
800 / B6	386	466	560	550	459	479	29	306.5	386.5	255	335	250	80	50	60.5	15	48	48	7	66.5	253.5	439.5	321		26.5
1250 / B6	386	466	560	550	459	479	29	306.5	386.5	255	335	250	80	60	65	16x11	48	48	7	66.5	253.5	439.5	320		29.25
1600/B7	478	598	560	550	461	479	29	388.5	518.5	347	467	250	120	90	43.5	12.5x5	54	54	8	66.5	253.5	439.5	288		15

Connection terminals

SIRCOVER and SIRCOVER Bypass 800 A / B6

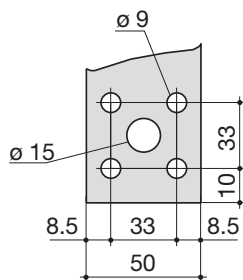

svr_077_a_1_x_cat

SIRCOVER and SIRCOVER Bypass 1250 A / B6

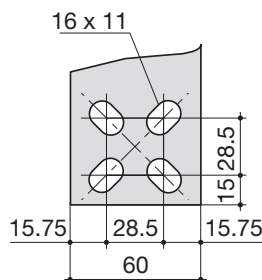

svr_078_b_1_x_cat

SIRCOVER 1600 to 3200 A / B7 to B8
SIRCOVER Bypass 1600 A / B7

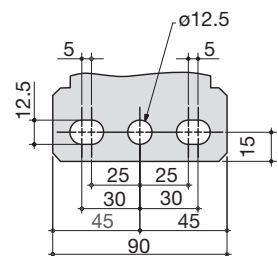

svr_098_a_1_x_cat

SIRCOVER

Manual Transfer Switching Equipment
from 125 to 3200 A

Dimensions for external handles

SIRCOVER 125 to 630 A / B3 to B5

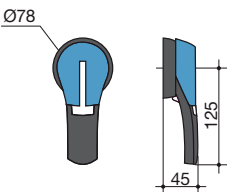
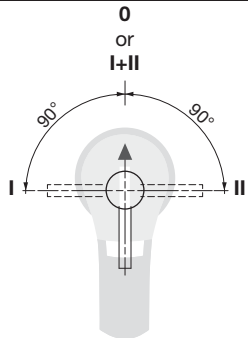
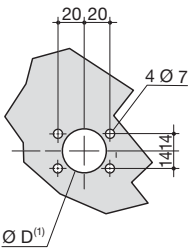
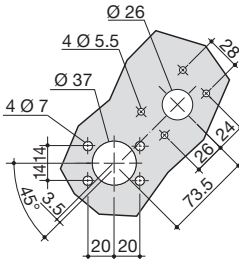
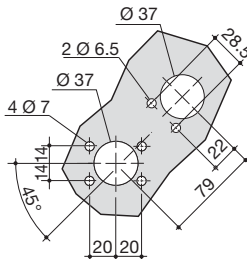
Handle type	Front operation Direction of operation	Door drilling		
S2 type 			With lock RONIS EL11AP 	With lock CASTELL K 

(1) Ø31 to Ø37: rear screw mounting,
Ø37: front clip mounting.

poign_030_a_1_gb_cat

SIRCOVER 800 to 1600 A / B6 to B7

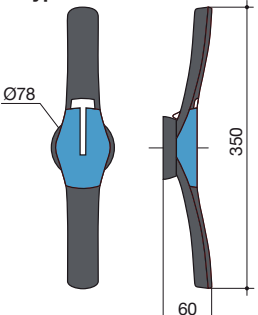
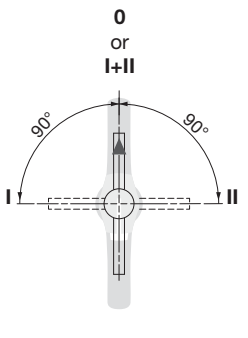
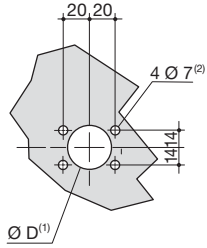
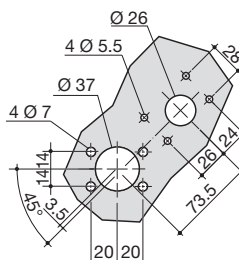
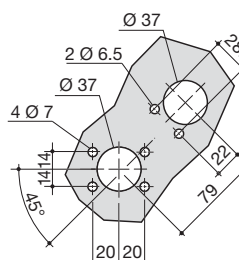
Handle type	Front operation Direction of operation	Door drilling		
S4 type 			With lock RONIS EL11AP 	With lock CASTELL K 

(1) Ø31 to Ø37: rear screw mounting,
Ø37: front clip mounting.
(2) Ø6 to Ø7: clip mounting

poign_031_a_1_gb_cat

SIRCOVER 2000 to 3200 A / B8

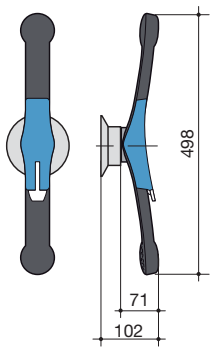
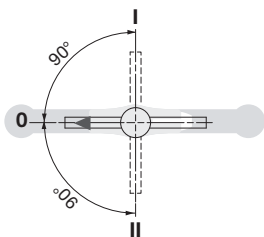
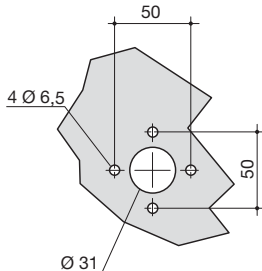
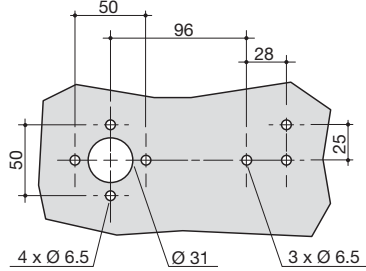
Handle type	Front operation Direction of operation	Door drilling	
S5 type with V Escutcheon 			With lock CASTELL K 

poign_023_a_1_gb_cat

SIRCOVER Bypass 125 to 200 A / B3

Handle type	Front operation Direction of operation	Door drilling	
S2 type			<div style="display: flex; justify-content: space-around;"> <div> <p>With lock RONIS EL11AP</p> </div> <div> <p>With lock CASTELL K</p> </div> </div>

(1) Ø31 to Ø37: rear screw mounting,
Ø37: front clip mounting.

poign_032_a_1_gb_cat

SIRCOVER Bypass 250 to 630 A / B4 to B5

Handle type	Front operation Direction of operation	Door drilling	
S3 type			<div style="display: flex; justify-content: space-around;"> <div> <p>With lock RONIS EL11AP</p> </div> <div> <p>With lock CASTELL K</p> </div> </div>

(1) Ø31 to Ø37: rear screw mounting,
Ø37: front clip mounting.

poign_033_a_1_gb_cat

SIRCOVER Bypass 800 to 1600 A / B6 to B7

Handle type	Front operation Direction of operation	Door drilling	
J4 type			<p>With lock CASTELL K</p>

poign_080_a_1_gb_cat

The *ATyS M* range: safe and reliable solutions

A complete range of automatic and remotely operated transfer switches from 40 to 160 A

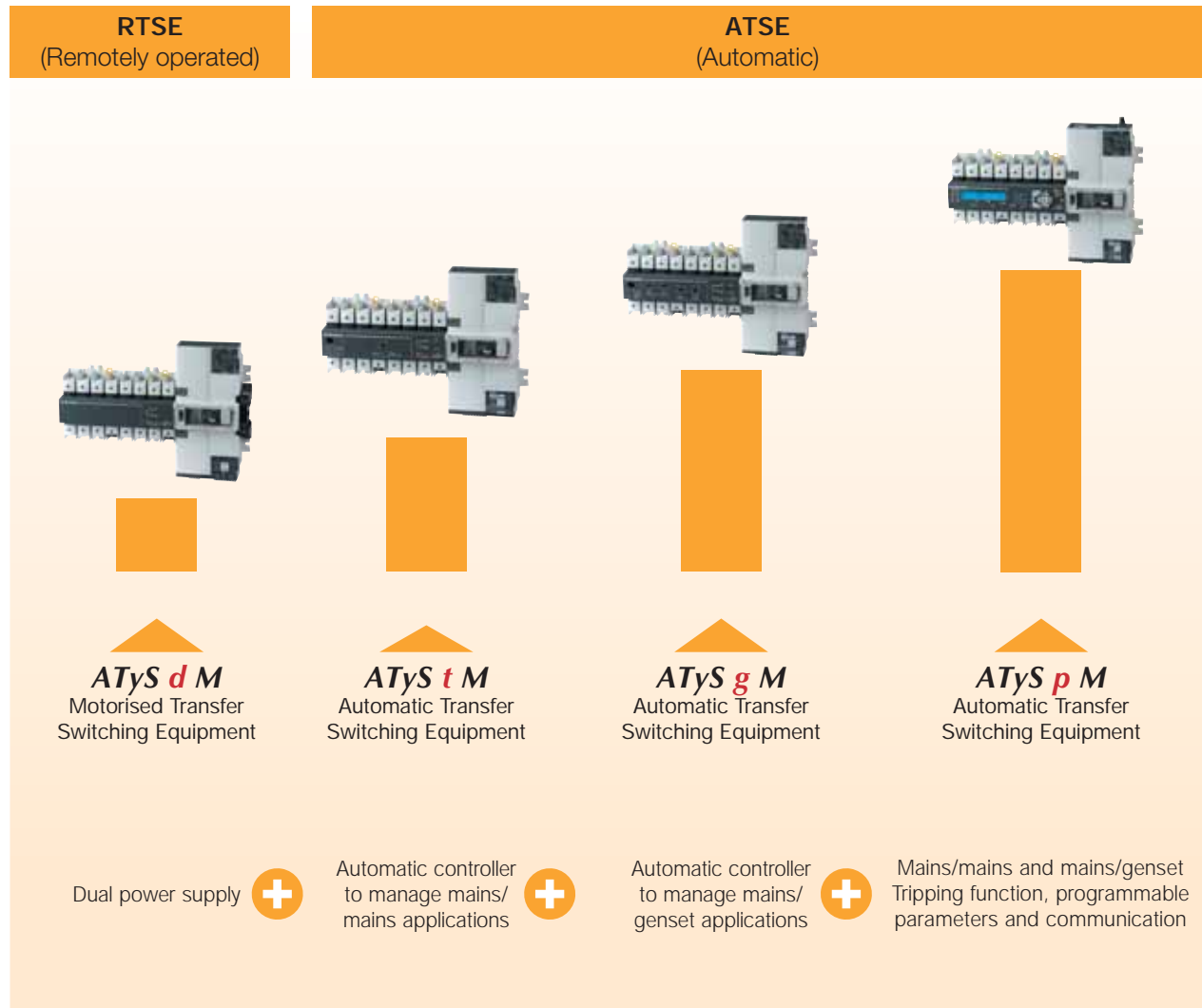

The advantages



Secure operation

- Electrical and mechanical interlocking for optimum safety.
- Positive break indication with two mechanical switch position indicators for clear and secure use.
- Padlocking in the 0 position enables the lockout function on each product.
- Padlocking in 3 positions can also be configured prior to installation.
- Permanent indication of product availability thanks to the Watchdog relay, which constantly monitors the product operating conditions (ATyS g M and AtyS p M).



High performance

- On-load making and isolation for using a single product with any load type, including inductive loads (AC-33).
- Immunity to control voltage fluctuations thanks to stable positions and power supply only required during switching.
- Excellent dynamic withstand for improved safety when closing on a short-circuit.
- Extremely low electrical blackout time (ATyS d M < 90ms) guaranteed thanks to the electromagnetic actuator technology used with rotary self-cleaning contacts.



A fully compact solution

- All-in-one solution, with minimum risk of incorrect mounting or wiring.
- Highly reliable thanks to the compliance with IEC 60947-6-1, the standard governing transfer switching equipment.
- Simplified ordering process: a single reference for the complete solution.



Intuitive use

- Manual emergency control:
The product can be operated **quickly and safely** using an emergency handle.
- Simple selection of operating mode (Auto/Manual) using an integrated selector.



Rapid commissioning

- **ATyS d M**: No configuration required.
- **ATyS t M** and **ATyS g M**: Configuration in just a few minutes using a screwdriver.
- **ATyS p M**: Simplified configuration (EASY CONFIG software and LCD screen on the device).



Easy to install

- Two switching devices mounted side-by-side for easy access to cabling with installation in a standard 18 module enclosure (product has a very low depth).
- Quick and easy mounting on a DIN rail or back plate.
- Simplified wiring thanks to the cage clamp terminals and dedicated bridging bars that allows a common outgoing connection whilst retaining the cage terminal connections.

Performance

IEC 60947-6-1 / GB 14048-11

- > AC 32B - up to 160 A
- > AC 33B - up to 125 A
- > AC 33iB - up to 160 A
Class PC switch technology

IEC 60947-3

- > AC 23B - up to 160 A

Enclosed ATyS M



See "Enclosed transfer switches" pages.

Expert Services

- > Study, definition, advice, implementation, maintenance and training...
- > Our Expert Services team offers customised support to make your project a success.



ATyS d M

Remotely operated Transfer Switching Equipment
from 40 to 160 A



ATyS d M
I-O-II 4P

The solution for

- > Applications with a normal/emergency external controller
- > Building Management System (BMS)



Strong points

- > Secure
- > Superior electrical performance
- > High-speed transfer
- > Immune to voltage fluctuations

Conformity to standards

- > IEC 60947-6-1
- > IEC 60947-3
- > GB/T 14048.11



Approvals and certifications



Function

ATyS d M devices are 2 pole or 4 pole transfer switches that are remotely controlled using volt-free contacts from an external controller. They are modular products with positive break indication. They are intended for use in low voltage power supply systems where a brief interruption of the load supply is acceptable during transfer.

Advantages

Secure

ATyS M have both electrical and mechanical interlocks for optimum security. They also feature a positive break indicator, confirming switch position with dual mechanical indicators for increased safety.

Superior electrical performance

ATyS M devices are compliant with IEC 60947-6-1, the standard governing transfer switches. Their AC-33B properties of up to 125 A mean you can use the same product for resistive and inductive loads.

High-speed transfer

ATyS d M devices are based on a coil solution with rotating contacts, therefore ensuring an extremely short black-out duration (< 90ms).

Immune to voltage fluctuations

The power supply of the ATyS d M is only active during transfer. As the product is based on stable positions, it is not affected by network voltage fluctuations.

Operating modes



ATySm_014_c

Easy selection of AUT/MAN mode



ATySm_015_c_1_cat

Manual emergency operation



ATySm_016_c_1_cat

Padlocking facility

What you need to know

Electrical control

The positions are controlled by dry contacts on any external automated system (e.g. ATyS C25).
These positions are stable even in case of loss of input supply.

Control logic

Two types of control logic are offered:

- Pulse logic
 - A switching command of at least 60 ms is necessary to initiate operation.
 - Commands I and II have priority over command 0.
 - The first command received (I or II) has priority as long as it remains present.
- Contactor logic
 - Command 0 must be maintained.
 - If command I or II disappears, the device returns to position 0, so long as the power supply is available.

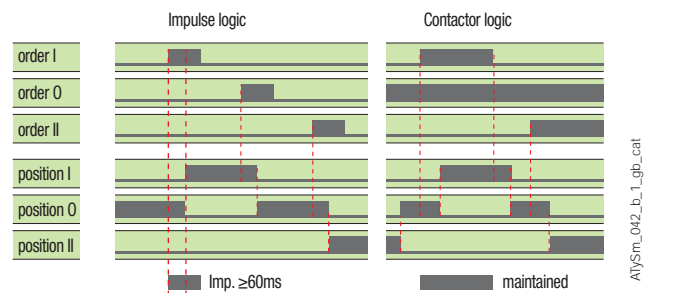
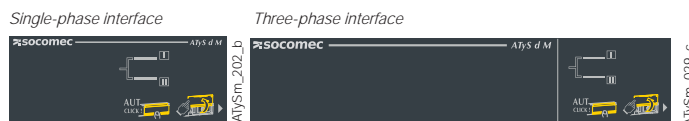

Power supply

The ATyS d M is equipped with two independent 230 VAC power inputs (176-288 VAC), 50/60 Hz (45/65 Hz).
These two supplies can be connected individually; one to switch I and the other to switch II:

- Power supply 101-102 must be available to reach position I
- Power supply 201-202 must be available to reach position II.

The use of a dual power supply (DPS) or an external supply module secures the command of the 3 positions irrespective of the power supply source.

In this case, both the supply inputs must be connected in parallel.

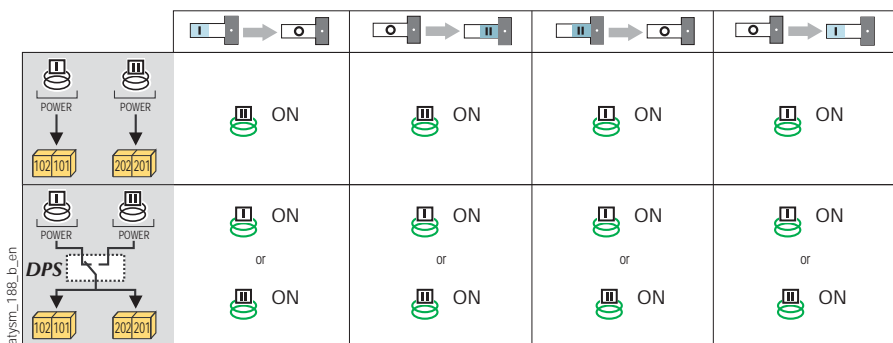

References

ATyS d M

Rating (A)	No. of poles	ATyS d M	Bridging bars	Voltage sensing and power supply tap	Terminal shrouds	Auxiliary contact block
40 A	2 P	9323 2004	2 P 1309 2006 4 P 1309 4006	2 pieces 1399 4006	2 pieces 2294 4016 ⁽¹⁾	1 st unit included 2 nd unit Separate common points 1309 1001 ⁽²⁾ Linked common points 1309 1011 ⁽²⁾
	4 P	9323 4004				
63 A	2 P	9323 2006				
	4 P	9323 4006				
80 A	2 P	9323 2008				
	4 P	9323 4008				
100 A	2 P	9323 2010				
	4 P	9323 4010				
125 A	2 P	9323 2012				
	4 P	9323 4012				
160 A	2 P	9323 2016	1309 2016			
	4 P	9323 4016	1309 4016			

(1) For the three-phase version, for complete upstream and downstream protection, please order 2x; for the single-phase version please order the part just 1x.
(2) 1 NO/NC contact block for positions I, 0 and II.

ATyS *t* M - ATyS *g* M

Automatic Transfer Switching Equipment
from 40 to 160 A



The solution for

- > High-rise buildings
- > Data centers
- > Healthcare buildings



Strong points

- > Fast commissioning
- > ATyS d M with an integrated controller for dedicated mains/mains or mains/genset functions
- > Secure programming

Conformity to standards

- > IEC 60947-6-1
- > IEC 60947-3
- > GB/T 14048.11



Approvals and certifications⁽¹⁾



⁽¹⁾ Product references on request.

Function

ATyS *t* M and ATyS *g* M are modular automatic transfer switches with positive break indication. ATyS *t* M are 4 pole (three-phase) devices and ATyS *g* M are 2 or 4 pole (single or three-phase) devices.

They have all the functions of the ATyS *d* M together with an integrated controller, giving them automatic features dedicated to mains/mains (ATyS *t* M) and mains/genset (ATyS *g* M) applications. They are intended for use in low voltage power supply systems where a brief interruption of the load supply is acceptable during transfer.

Advantages

Quick start

ATyS *t* M and *g* M transfer switches offer significant time saving during commissioning (the process takes 2 to 3 minutes). Thanks to the design that allows commissioning through just one potentiometer (4 on the ATyS *g* M) and four DIP switches, a screwdriver is all that is required to configure the parameters.

ATyS *g* M: dedicated to mains/genset applications

In addition to its single-phase and three-phase voltage & frequency monitoring for both incoming sources, the product's integrated controller also features functions that are specific to mains/genset applications (genset control, test on load, etc.).

ATyS *t* M: dedicated to three-phase mains/mains applications

The ATyS *t* M integrated controller has been designed to provide all the functions necessary for these applications (operation with or without priority, preferred source selection) together with the monitoring of the voltage and frequency of both sources for three-phase networks.

Secure programming

To ensure that the correct configuration is maintained an optional sealable cover can be fitted in order to avoid any unintentional modifications to the programming.

What you need to know

The ATyS t M and ATyS g M are automatic transfer switching equipment that include a fully integrated ATS controller. These products are self powered from incoming supplies: 230 VAC (176-288 VAC), 50/60 Hz (45/65Hz).

References

ATyS t M

Rating (A)	No. of poles	Network (VAC)	ATyS t M	Bridging bars	Voltage sensing and power supply tap	Terminal shrouds	Auxiliary contact block	Sealable cover
40 A	4 P	230/400	9344 4004	4 P 1309 4006	2 pieces 1399 4006	2 pieces 2294 4016 ⁽¹⁾	1 unit Separate common points 1309 1001 ⁽²⁾ Linked common points 1309 1011 ⁽²⁾	1359 0000
63 A	4 P	230/400	9344 4006					
80 A	4 P	230/400	9344 4008					
100 A	4 P	230/400	9344 4010					
125 A	4 P	230/400	9344 4012					
160 A	4 P	230/400	9344 4016	1309 4016				

(1) For complete upstream and downstream protection please order quantity 2.

(2) 1 NO/NC contact block for positions I, 0 and II.

ATyS g M

Rating (A)	No. of poles	Network (VAC) ⁽³⁾	ATyS g M	Bridging bars	Voltage sensing and power supply tap	Terminal shrouds	Auxiliary contact block	Sealable cover
40 A	2 P	230	9353 2004	2 P 1309 2006 4 P 1309 4006	2 pieces 1399 4006	2 pieces 2294 4016 ⁽¹⁾	1 unit Separate common points 1309 1001 ⁽²⁾ Linked common points 1309 1011 ⁽²⁾	2 P 1359 2000 4 P 1359 0000
	4 P	230/400	9354 4004					
63 A	2 P	230	9353 2006					
	4 P	230/400	9354 4006					
80 A	2 P	230	9353 2008					
	4 P	230/400	9354 4008					
100 A	2 P	230	9353 2010					
	4 P	230/400	9354 4010					
125 A	2 P	230	9353 2012					
	4 P	230/400	9354 4012					
160 A	2 P	230	9353 2016	1309 2016				
	4 P	230/400	9354 4016	1309 4016				

(1) 4 pole version - for complete upstream and downstream protection please order quantity 2; for 2 pole version order quantity 1.

(2) 1 NO/NC contact block for positions I, 0 and II.

(3) For 127/230VAC networks, please contact your supplier.

ATyS p M

Automatic Transfer Switching Equipment
from 40 to 160 A



ATyS p M
I-0-II 4P

Function

ATyS p M are single-phase or three-phase modular automatic transfer switches with positive break indication.

Functions include ATyS t M and ATyS g M capability, with additional programmable parameters and a tripping function. A product model with communication is available. They are intended for use in low voltage power supply systems where a brief interruption of the load supply is acceptable during transfer.

Advantages

Flexible programming

ATyS p M time delays and inputs/outputs are completely configurable, hence enabling the easy monitoring of specific applications (load shedding, test...) and the definition of an operating cycle specifically adapted to your application.

Trip function

ATyS p M features a function for returning to the 0 position in case of the loss of both power supply sources (tripping). This protects the load from issues due to source instability.

Communication and configuration

A specific version of ATyS p M is available with integrated Modbus communication. This gives access to most product data (status, voltages, frequencies...). A user friendly configuration software is also available free (Easyconfig) to configure, view and save all the parameters in the ATyS p M.

Remote control interface

Specifically designed for installations where the product is enclosed, the remote interface displays product status on the front panel (D10) or displays and controls with access to programming (D20).

The solution for

- > High-rise buildings
- > Data centres
- > Healthcare buildings
- > Banks and insurance companies
- > Transport (airports, tunnels, etc.)



Strong points

- > Flexible programming
- > Trip function
- > Communication and configuration
- > Remote control interface

Conformity to standards

- > IEC 60947-6-1
- > IEC 60947-3
- > GB/T 14048.11



Approvals and certifications



What you need to know

The ATyS p M are automatic transfer switching equipment that include a fully integrated ATS controller. These products are self powered from incoming supplies: 230 VAC (160-305 VAC), 50/60 Hz (45/65Hz). Automatic products are all equipped with a sequence logic. Here is an example of the sequence logic in case of loss and return of the preferred source.

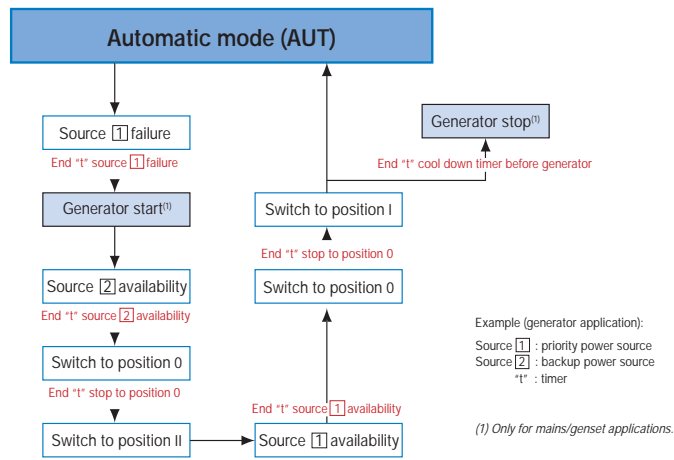

atys_028_h_1_gb_cat

Easyconfig

Easyconfig software is the ideal solution to save time and simplify complex configuration.

You can configure the following parameters:

- application type,
- voltage and frequency thresholds,
- timers,
- inputs/outputs...

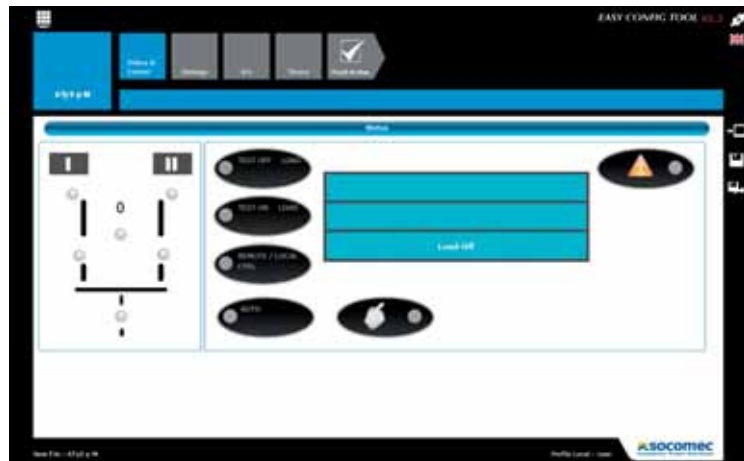

atys_849_b_gb

ATyS p M

Rating (A)	No. of poles	Network (VAC) ⁽³⁾	ATyS p M	ATyS p M + com	Bridging bars	Voltage sensing and power supply tap	Terminal shrouds	Auxiliary contact block	Remote interface
40 A	4 P	230/400	9364 4004	9384 4004	4 P 1309 4006	2 pieces 1399 4006	2 pieces 2294 4016 ⁽¹⁾	1 piece	D10 9599 2010 D20 9599 2020
63 A	4 P	230/400	9364 4006	9384 4006				Separate common points 1309 1001 ⁽²⁾	
80 A	4 P	230/400	9364 4008	9384 4008				Linked common points 1309 1011 ⁽²⁾	
100 A	4 P	230/400	9364 4010	9384 4010					
125 A	4 P	230/400	9364 4012	9384 4012					
160 A	4 P	230/400	9364 4016	9384 4016	1309 4016				

(1) For complete upstream and downstream protection please order quantity 2.

(2) 1 NO/NC contact block for positions I, 0 and II.

(3) For 127/230VAC networks, please contact us.

ATyS M range

ATyS **d** M, ATyS **t** M, ATyS **g** M, ATyS **p** M
from 40 to 160 A

Accessories

Bridging bars

Use

Used to bridge the outgoing common connection between switch I and switch II. The bridging bar does not reduce the connection capacity of the cage terminals.

Rating (A)	No. of poles	Reference
40 ... 125	2 P	1309 2006
160	2 P	1309 2016
40 ... 125	4 P	1309 4006
160	4 P	1309 4016

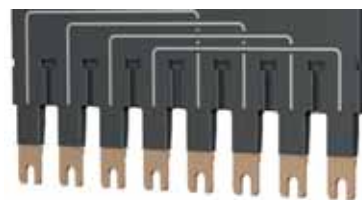

atysm_025.eps

Voltage sensing and power supply tap

Use

It allows connection of $2 \times \leq 1.5 \text{ mm}^2$ voltage sensing or power cables.

The single-pole voltage sensing tap can be mounted in any of the terminals (incoming) without reducing their connecting capacity.

Rating (A)	Pack	Reference
40 ... 160	2 pieces	1399 4006



atysm_026_a.eps

Terminal shrouds

Use

Protection against direct contact with terminals or connecting parts.

Advantages of the terminal shrouds

Perforations allow remote thermographic inspection without the need to remove the shrouds. Possibility of sealing.

Mounting

For complete upstream and downstream protection of 4 pole products, please order quantity 2; for 2 pole products please order quantity 1.

Rating (A)	Position	Reference
40 ... 160	top / bottom	2294 4016 ⁽¹⁾

(1) Reference composed of 2 pieces.

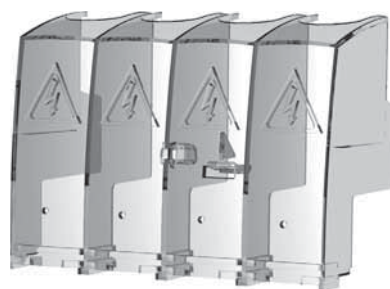

atysm_027_a.eps

Auxiliary contact

Use

A maximum of two auxiliary contact blocks can be fitted to each product. Each auxiliary contact block integrates 3 NO/NC auxiliary contacts (I, O, II).

The ATyS d M is delivered as standard with 1 block with separate common points.

Characteristics:

250 VAC / 5 A maximum.

24 VDC / 2 A maximum.

Rating (A)	Type	Reference
40 ... 160	Separate common points	1309 1001
40 ... 160	Linked common points	1309 1011



acces_353.eps



acces_398.eps

Sealable cover

Use

Prevents access to the ATyS t M and ATyS g M configuration panels.

Rating (A)	No. of poles	Reference
40 ... 160	2 P	1359 2000
40 ... 160	4 P	1359 0000



atysm_313.eps

Polycarbonate enclosure

Use

Dedicated to the installation of a three-phase ATyS M, it enables easy integration of a compact transfer switch solution.

Rating (A)	H x W x D (mm)	Reference
40 ... 160	385 x 385 x 193	1309 9006



Extension unit

Use

Combined with the polycarbonate enclosure, the extension unit provides additional space in order to connect 70 mm² cables to the ATyS M with ease.

Rating (A)	Reference
40 ... 160	1309 9007



Residential enclosure

Use

Dedicated to the implementation of a single-phase ATyS M, the plastic enclosure provides a compact IP41 transfer switch solution with easy integration.

Rating (A)	H x W x D (mm)	Reference
40 ... 160	410 x 305 x 150	1309 9056



Double power supply - DPS

Use

Allows an ATyS *d* M to be supplied by two 230 VAC 50/60 Hz networks.

Input

- The input is considered as "active" from 200 VAC.
- Maximum voltage: 288 VAC.
- Internal protection: each input is fuse protected (3.15 A).
- Connection on terminals: max. 6 mm².
- Modular product: the width of 4 modules.

Description of accessories	Reference
DPS	1599 4001

Input 1	Input 2	Output
230 VAC	0 VAC	230 VAC (input 1)
0 VAC	230 VAC	230 VAC (input 2)
230 VAC	230 VAC	230 VAC (input 1)
0 VAC	0 VAC	0 VAC

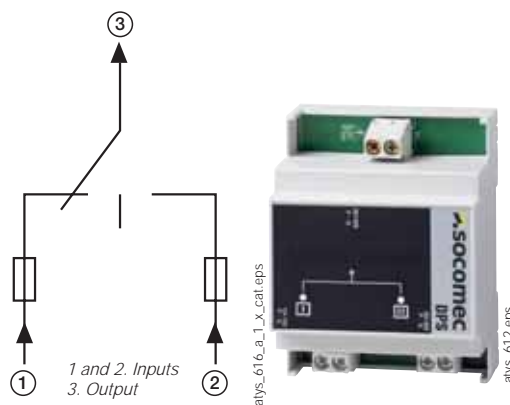

ATyS M range

ATyS d M, ATyS t M, ATyS g M, ATyS p M

from 40 to 160 A

Accessories (continued)

Auto-transformer

Use

For use with ATyS M in 400 VAC three-phase applications that have no distributed neutral.

The ATyS M includes integrated sensing and power supply circuits, therefore a neutral connection is required for 400 VAC three-phase applications. When no neutral connection is available this autotransformer (400/230 VAC, 400 VA) provides the 230 VAC required for the ATyS to function.



trafo_165.eps

Rating (A)	Reference
40 ... 160	1599 4121

Remote interfaces for ATyS p M

Use

To remotely display source availability and position indication on the front of a panel when the ATyS M is enclosed.

The remote interface is powered directly from the ATyS M via the RJ45 connection cable. Maximum cable length: 3 m.

D10

To display source availability and position indication on the front panel of an enclosure.

Protection degree: IP21.

D20

In addition to the functions of the D10, the D20 displays measurements and enables control and configuration from the front of the display panel.

Protection degree: IP21.

Door mounting

2 holes \varnothing 22.5.

ATyS M connection via RJ45 cable, not isolated.

Cable not provided.



aty_s_564.eps



aty_s_565.eps



aty_s_597.eps

RJ45 to connect to ATyS p M

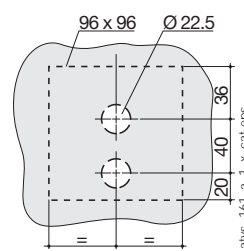

Drillings

aty_s_161_a_1_x_cat.eps

Description of accessories	Reference
D10	9599 2010
D20	9599 2020

Connecting cable for remote interfaces

Use

To connect between a remote interface (type D10 or D20) and a control product (ATyS p M).

Characteristics:

RJ45 8 wire straight-through, non isolated cable. Length 3 m.



access_209.eps

Type	Length	Reference
RJ45 cable	3 m	1599 2009

Cage-terminal interface

Use

The power connection terminals allow conversion of the cage clamp terminals into bolt-on type connection terminals, enabling connection of up to two 35 mm² cables or one 70 mm² cable. Compatible with aluminium terminals. Each power connection terminal is provided with separation screens.



aty_s_m_252.psd

Rating (A)	Reference
40 ... 160	1399 4017 ⁽¹⁾

(1) For complete conversion, order quantity 3.

Dimensions

ATyS M 40 to 160 A

Single-phase ATyS M

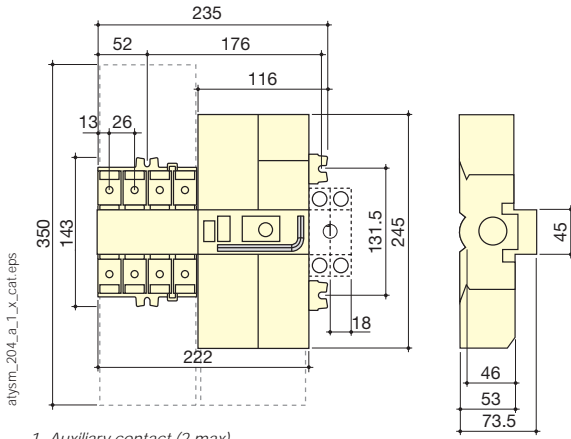

1. Auxiliary contact (2 max).

Three-phase ATyS M

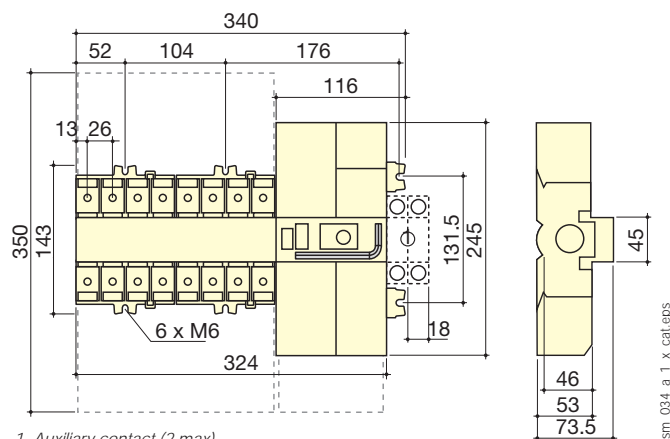

1. Auxiliary contact (2 max).

Single-phase ATyS M - door cut-out

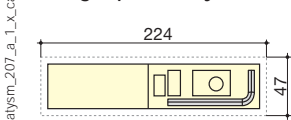

Three-phase ATyS M - door cut-out

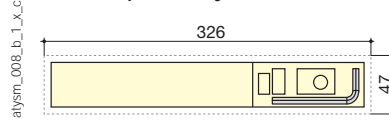

Terminals and connections

Single-phase ATyS d M

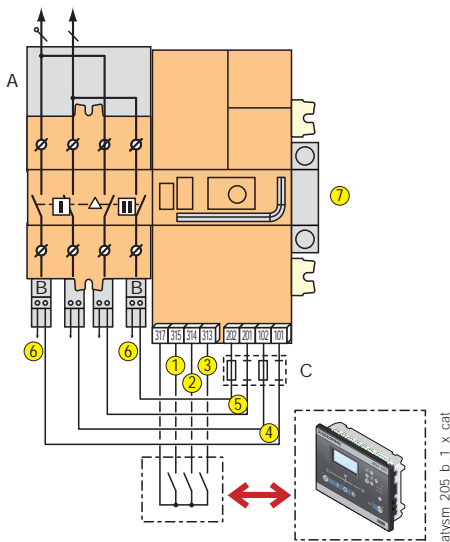

Three-phase ATyS d M

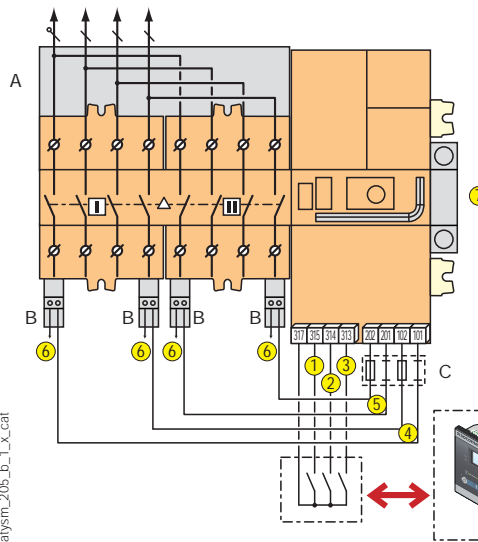

- 1: position I control
- 2: position II control
- 3: position 0 control C
- 4: power supply I (230 VAC)
- 5: power supply II (230 VAC)
- 6: voltage tap
- 7: auxiliary contact block - 1 NO/NC per position I, 0, II (factory fitted)

- A: bridging bar (accessory)
- B: voltage sensing tap (accessory)
- C: F1 / F2 = fuse 10 A gG

ATyS M range

ATyS d M, ATyS t M, ATyS g M, ATyS p M

from 40 to 160 A

Terminals and connections (continued)

Three-phase ATyS t M

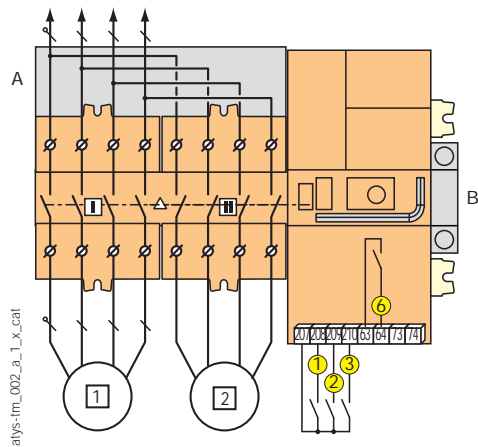

- 1 primary source (network)
- 2 backup source (network)

- 1: position 0 control
- 2: preferred source selection
- 3: automatic mode inhibition
- 6: availability S1 or S2

A: bridging bar (accessory)
B: auxiliary contact block - 1 NO/NC per position I, 0, II (accessory)

Single-phase ATyS g M

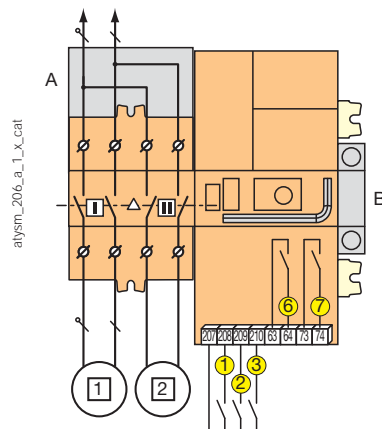

Three-phase ATyS g M

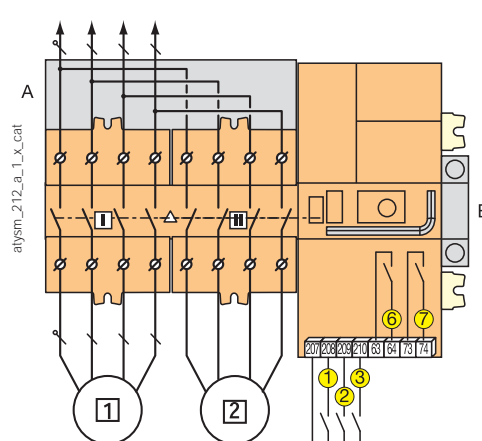

- 1 primary source
- 2 backup source

- 1: manual retransfer /priority change
- 2: test on load
- 3: automatic mode inhibition
- 6: relay for product availability
- 7: genset start / stop control

A: bridging bar (accessory)
B: auxiliary contact block - 1 NO/NC per position I, 0, II (accessory)

Three-phase ATyS p M

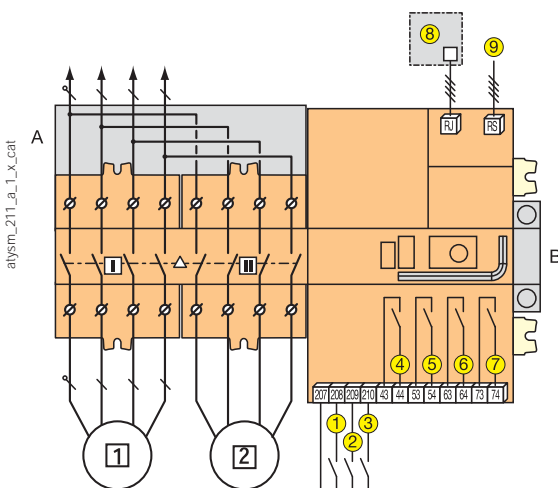

- 1 primary source
- 2 backup source

- 1 - 2 - 3: programmable inputs
- 4 - 5 - 6: programmable outputs
- 7: genset start / stop control
- 8: RJ45 for connecting a D10/D20 remote interface.
- 9: RS485 for communication on versions with COM.

A: bridging bar (accessory)
B: auxiliary contact block - 1 NO/NC per position I, 0, II (accessory)

Characteristics according to IEC 60947-3 and IEC 60947-6-1

40 to 160 A

Thermal current I_{th} at 40°C	40 A	63 A	80 A	100 A	125 A	160 A
Rated insulation voltage U_i (V) (power circuit)	800	800	800	800	800	800
Rated impulse withstand voltage U_{imp} (kV) (power circuit)	6	6	6	6	6	6
Rated insulation voltage U_i (V) (control circuit)	300	300	300	300	300	300
Rated impulse withstand voltage U_{imp} (kV) (control circuit) - ATyS d M	4	4	4	4	4	4
Rated impulse withstand voltage U_{imp} (kV) (control circuit) - ATyS t M, g M and p M	2.5	2.5	2.5	2.5	2.5	2.5

Rated operational currents I_e (A) according to IEC 60947-6-1

Rated voltage	Utilisation category	A/B ⁽¹⁾	A/B ⁽¹⁾	A/B ⁽¹⁾	A/B ⁽¹⁾	A/B ⁽¹⁾	A/B ⁽¹⁾
415 VAC	AC-31 A / AC-31 B	40/40	63/63	80/80	100/100	100/125	100/160
415 VAC	AC-32 A / AC-32 B	40/40	63/63	80/80	100/100	100/125	100/160
415 VAC	AC-33 A / AC-33 B	-/40	-/63	-/80	-/100	-/125	-/125

Rated operational currents I_e (A) according to IEC 60947-3

Rated voltage	Utilisation category	A/B ⁽¹⁾	A/B ⁽¹⁾	A/B ⁽¹⁾	A/B ⁽¹⁾	A/B ⁽¹⁾	A/B ⁽¹⁾
415 VAC	AC-20 A / AC-20 B	40/40	63/63	80/80	100/100	125/125	160/160
415 VAC	AC-21 A / AC-21 B	40/40	63/63	80/80	100/100	125/125	160/160
415 VAC	AC-22 A / AC-22 B	40/40	63/63	80/80	100/100	125/125	160/160
415 VAC	AC-23 A / AC-23 B	40/40	63/63	80/80	100/100	125/125	125/160
690 VAC	AC-21 A / AC-21 B	40/40	63/63	80/80	100/100	125/125	160/160
690 VAC	AC-22 A / AC-22 B	40/40	63/63	80/80	80/80	100/125	100/125
690 VAC	AC-23 A / AC-23 B	40/40	63/63	63/63	80/80	80/80	80/80

Current rated as conditional short-circuit with fuse gG DIN

Conditional short-circuit current (kA rms)	50	50	50	50	50	40
Associated fuse rating (A)	40	63	80	100	125	160

Current rated as conditional short-circuit with any brand of circuit breaker that ensures tripping in less than 0.3s⁽⁴⁾

Current rated as short-time withstand low 0.3s (kA rms)	7	7	7	7	7	7
---	---	---	---	---	---	---

Short-circuit operation (switch only)

Current rated as short-time withstand I_{cw} 1s (kA rms) ⁽²⁾	4	4	4	4	4	4
Rated peak withstand current (kA peak) ⁽²⁾	17	17	17	17	17	17

Connection

Minimum connection cross-section (mm ²)	10	10	10	10	10	10
Maximum Cu cable cross-section (mm ²)	70	70	70	70	70	70
Tightening torque (Nm)	5	5	5	5	5	5

Switching time⁽⁵⁾

I - 0 or II - 0, following a command (ms)	45	45	45	45	45	45
Transfer time I - II or II - I, following a command (ms)	180	180	180	180	180	180
I-0 or II-0, after outage (s)	1.2	1.2	1.2	1.2	1.2	1.2
I-II or II-I transfer time, after outage (s)	1.4	1.4	1.4	1.4	1.4	1.4
Contact transfer time ("black-out") I-II min. (ms) ⁽³⁾	150	150	150	150	150	150

Power supply

Min./max. auxiliary power supply (VAC) (ATyS d M, t M and g M)	176/288	176/288	176/288	176/288	176/288	176/288
Min./max. auxiliary power supply (VAC) (ATyS p M)	160/305	160/305	160/305	160/305	160/305	160/305

Control supply power demand

Rated power (VA)	6	6	6	6	6	6
Max. intensity at 230 VAC (A) - ATyS d M, t M and g M	30	30	30	30	30	30
Max. intensity at 230 VAC (A) - ATyS p M	20	20	20	20	20	20

Mechanical specifications

Durability (number of operating cycles)	10,000	10,000	10,000	10,000	10,000	10,000
Weight of single-phase models - non-packaged (kg)	2.8	2.8	2.8	2.8	2.8	2.8
Weight of single-phase models - including packaging (kg)	3.5	3.5	3.5	3.5	3.5	3.5
Weight of three-phase models - non-packaged (kg)	3.5	3.5	3.5	3.5	3.5	3.5
Weight of three-phase models - including packaging (kg)	4.2	4.2	4.2	4.2	4.2	4.2

(1) Category with index A = frequent operation / Category with index B = infrequent operation.

(2) For a rated operational voltage $U_o = 400$ VAC.

(3) 5% tolerance.

(4) Value for coordination with any circuit breaker that ensures tripping in less than 0.3s.

For coordination with specific circuit-breaker references, higher short-circuit current values are available. Please contact us.

(5) At rated voltage - excluding time delays, where applicable.

The **ATyS S** range: a robust solution

A range of transfer switches from 40 to 125 A

RTSE
(Remotely operated)



ATyS S

Motorised Transfer
Switching Equipment



ATyS d S
Motorised Transfer
Switching Equipment

Dual power supply

+ (plus sign icon)

Three application types

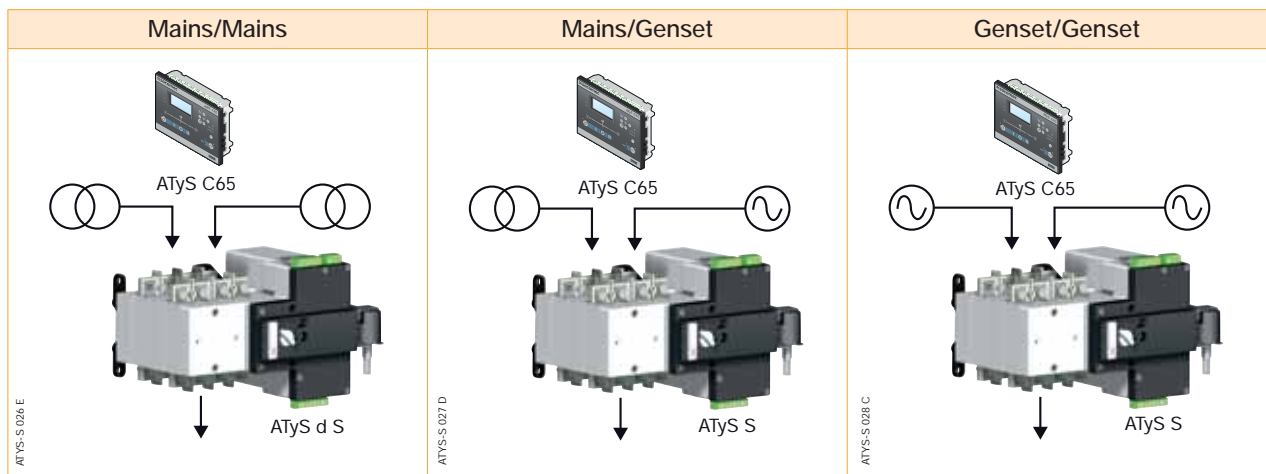

The advantages



Safe and reliable

- An extended lifetime thanks to a switching principle based on stable positions.
- Positive break indication.
- Mechanical position interlocking.
- Stable power supply to the loads because the ATyS S does not require power supply for the position to be maintained.
- Various power supply voltages are available: 12 or 24/48 VDC and 230 VAC or 2 x 230 VAC.



Easy to use

- Manual emergency control:
The product can be controlled **quickly and safely** using an emergency handle (motor installed or removed).
- Simple selection of the operating mode (Auto/Manual/Padlocked) using an integrated selector.



Total integration

- Integrated and tested solution: components factory assembled and wired.
- Reliable product: compliance with IEC 60947-6-1, the standard governing transfer switches.



Easy maintenance

- Self-cleaning sliding contacts.
- Easy replacement of the motor unit, even during on load operation.



Cost-saving

- Low power consumption thanks to a switching principle based on stable positions: power is only required during transfer.
- Easy and fast installation: only four fixing points, three connectors and the power cables to connect.
- Shorter bridging bars that are consequently more economical than any other solution on the market.

Compact design

- > Combining two switches mounted back-to-back and being only 197 mm wide, the ATyS S offers significant space saving when compared with a side-by-side solution.

Enclosed ATyS S



See "Enclosed transfer switches" pages.

Expert Services

- > Study, definition, advice, implementation, maintenance and training...
- > Our Expert Services team offers customised support to make your project a success.



ATyS S - ATyS d S

Remotely operated Transfer Switching Equipment
from 40 to 125 A



atys-s_018.psd

Function

ATyS S products are 4 pole remotely operated transfer switches with positive break indication. They enable the on-load transfer of two three-phase supplies via remote volt-free contacts, from either an external automatic controller, using pulse logic, or a switch. They are intended for use in low voltage power supply systems where a brief interruption of the load supply is acceptable during transfer.

Advantages

Extensive power supply range

The ATyS S is available in four supply versions, each with a broad range (+/-30%). The four versions are:

- 12 VDC power supply.
- 24/48 VDC power supply.
- 230 VAC single power supply.
- 2 x 230 VAC dual power supply.

Safety and reliability

ATyS S products use stable position technology, ensuring constant pressure on the contacts and preventing premature faults. In addition, they do not require a power supply to maintain position, thus protecting their loads from voltage fluctuations.

Easy integration

ATyS S products can be easily installed inside enclosures. Their design, and in particular their compact size, enables integration within most 200 mm deep enclosures.

Simplified maintenance

Maintenance can be carried out easily under load, with manual operation still available. The control and motorisation section can be replaced simply by removing 4 screws, with no work required on the installation cabling.

ATyS d S: Dual power supply

In addition to the functions offered by the ATyS S, the ATyS d S incorporates supply redundancy without the need for additional wiring. This is obtained by integrating a double supply (2 independent supplies) directly within the product.

The solution for

- > Genset < 90 kVA
- > Heating systems
- > Climate control
- > Ventilation systems
- > Telecommunications



Strong points

- > Extensive power supply range
- > Safety and reliability
- > Easy integration
- > Simplified maintenance
- > ATyS d S: Dual power supply

Conformity to standards

- > IEC 60947-6-1
- > IEC 60947-3
- > GB/T 14048-11



Approvals and certifications



Enclosed ATyS S



coff_417.psd

See "Enclosed transfer switches".

References

ATyS S

Rating (A)	No. of poles	Power supply	ATyS S	Bridging bars	Terminal shrouds	Voltage tap	Terminal retainer	DIN rail
40 A	4 P	24/48 VDC	9506 4004	4 P 9509 4013	Source side 2 pieces 9594 4012	9599 4001	2 pieces 9599 4003	4 modules 9599 4002
	4 P	12 VDC	9505 4004					
	4 P	230 VAC	9503 4004					
63 A	4 P	24/48 VDC	9506 4006					
	4 P	12 VDC	9505 4006					
	4 P	230 VAC	9503 4006					
80 A	4 P	24/48 VDC	9506 4008					
	4 P	12 VDC	9505 4008					
	4 P	230 VAC	9503 4008					
100 A	4 P	24/48 VDC	9506 4010		Load side 2 pieces 9594 9012	9599 4001		
	4 P	12 VDC	9505 4010					
	4 P	230 VAC	9503 4010					
125 A	4 P	24/48 VDC	9506 4012					
	4 P	12 VDC	9505 4012					
	4 P	230 VAC	9503 4012					

ATyS d S

Rating (A)	No. of poles	Power supply	ATyS d S	Bridging bars	Terminal shrouds	Voltage tap	Terminal retainer	DIN rail
40 A	4 P	2 x 230 VAC	9513 4004	4 P 9509 4013	Source side 2 pieces 9594 4012	9599 4001	2 pieces 9599 4003	4 modules 9599 4002
63 A	4 P	2 x 230 VAC	9513 4006					
80 A	4 P	2 x 230 VAC	9513 4008					
100 A	4 P	2 x 230 VAC	9513 4010					
125 A	4 P	2 x 230 VAC	9513 4012		Load side 2 pieces 9594 9012			

Accessories

Bridging bars

Use

For bridging power terminals on the top or bottom side of the switch.

Rating (A)	No. of poles	Reference
40 ... 125	4 P	9509 4013



Voltage tap

Use

Enables the required power supply for ATyS S 230 VAC and ATyS d S products to be tapped directly from the product's incoming power terminals. Can also be utilised in applications without neutral, to provide 400 VAC to the autotransformer.

Rating (A)	Reference
40 ... 125	9599 4001



Terminal retainer

Use

These clips have a dual function: - to prevent direct access to the power supply and control terminals and - to secure these connector terminals.

Rating (A)	Pack	Reference
40 ... 125	2 pieces	9599 4003



ATyS S - ATyS d S

Remotely operated Transfer Switching Equipment
from 40 to 125 A

Accessories (continued)

Terminal shrouds

Use

IP2X protection against direct contact with terminals or connecting parts.

Terminal shrouds for the source side

Rating (A)	Pack	Reference
40 ... 125	2 pieces	9594 4012

Terminal shrouds for the load side

Rating (A)	Pack	Reference
40 ... 125	2 pieces	9594 9012



Autotransformer 400/230 VAC

Use

For applications without neutral, this autotransformer provides the 230 VAC required to power these ATyS products.

Dimensions

75 x 80 x 72 mm

Rating (A)	Reference
40 ... 125	9599 4004

DIN rail

Use

This 4-module DIN rail can be installed directly on the front of the ATyS S and can be utilised, for example, for the installation of a surge protection device.

Rating (A)	Reference
40 ... 125	9599 4002



Spares

Manual emergency operation handle

Use

This handle can be used on the product whether the motor unit is mounted or not.

Rating (A)	Reference
40 ... 125	9599 5012



Connector kit

Use

This kit, including all the connector types for the different products, can be ordered in case of loss or breaking of one connector.

Rating (A)	Reference
40 ... 125	9509 0002



Characteristics according to IEC 60947-3 and IEC 60947-6-1

40 to 125 A

Thermal current I_{th} at 40°C	40 A	63 A	80 A	100 A	125 A
Rated insulation voltage U_i (V) (power circuit)	800	800	800	800	800
Rated impulse withstand voltage U_{imp} (kV) (power circuit)	6	6	6	6	6
Rated insulation voltage U_i (V) (control circuit)	300	300	300	300	300
Rated impulse withstand voltage U_{imp} (kV) (control circuit)	4	4	4	4	4

Rated operational currents I_e (A) according to IEC 60947-6-1

Rated voltage	Utilisation category	A/B	A/B	A/B	A/B	A/B
415 VAC	AC-31 B	40	63	80	100	125
415 VAC	AC-32 B	40	63	80	80	80

Rated operational currents I_e (A) according to IEC 60947-3

Rated voltage	Utilisation category	A/B	A/B	A/B	A/B	A/B
415 VAC	AC-20 A / AC-20 B	40/40	63/63	80/80	100/100	125/125
415 VAC	AC-21 A / AC-21 B	40/40	63/63	80/80	100/100	100/125
415 VAC	AC-22 A / AC-22 B	40/40	63/63	80/80	100/100	100/100
415 VAC	AC-23 A / AC-23 B	-/40	-/63	-/63	-/63	-/63

Fuse protected short-circuit withstand (kA rms prospective)

Prospective short-circuit current (kA rms)	50	50	50	25	15
Associated fuse rating (A)	40	63	80	100	125

Circuit breaker protected short-circuit withstand with any circuit breaker that ensures tripping in less than 0.3s⁽³⁾

Rated short-time withstand current 0.3s I_{cw} (kA rms)	3.5	3.5	3.5	3.5	3.5
---	-----	-----	-----	-----	-----

Short-circuit capacity as per IEC 60947-6-1

Rated short-time withstand current 0.03 s. (kA)	5	5	5	5	-
Rated short-circuit making capacity I_{cm} (kA peak)	7.65	7.65	7.65	7.65	-

Short-circuit capacity as per IEC 60947-3 (without protection)

Rated short-time withstand current 1 s. I_{cw} (kA rms)	2.5	2.5	2.5	2.5	2.5
Rated peak withstand current (kA peak)	12	12	12	12	12

Connection

Maximum Cu cable cross-section (mm ²)	50	50	50	50	50
Tightening torque mini / maxi (Nm)	1.2/3	1.2/3	1.2/3	1.2/3	1.2/3

Switching time (Standard setting)

I - 0 or II - 0 (ms)	500	500	500	500	500
I - II or II - I (ms)	1000	1000	1000	1000	1000
Duration of "electrical blackout" I - II (ms) minimum	500	500	500	500	500

Power supply

Power supply 12 VDC min / max (VDC)	9/15	9/15	9/15	9/15	9/15
Power supply 24/48 VDC min / max (VDC)	17/62	17/62	17/62	17/62	17/62
Power supply 230 VAC min / max (VAC)	160/310	160/310	160/310	160/310	160/310

Control supply power demand

Power supply 12 VDC inrush / nominal (VA)	200/40	200/40	200/40	200/40	200/40
Power supply 24/48 VDC inrush / nominal (VA)	200/40	200/40	200/40	200/40	200/40
Supply 230 VAC inrush / nominal (VA)	200/40	200/40	200/40	200/40	200/40

Mechanical characteristics

Durability (number of operating cycles)	25 000	25 000	25 000	25 000	25 000
Weight ATyS S and ATyS d S 4 P (kg)	3	3	3	3	3

(1) Value for coordination with any circuit breaker that ensures tripping in less than 0.3s. For coordination with specific circuit-breaker references, higher short-circuit current values are available. Please consult us.

ATyS S - ATyS d S

Remotely operated Transfer Switching Equipment

from 40 to 125 A

Terminals and connections

ATyS S DC version

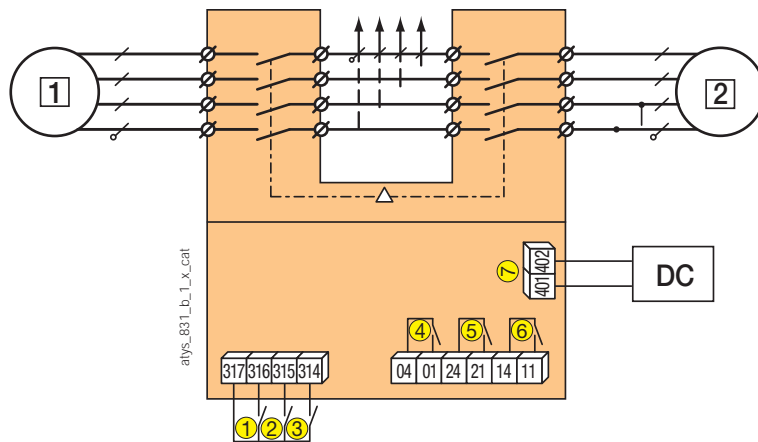

- 1 preferred source
- 2 alternate source
- 1: position 0 control
- 2: position I control
- 3: position II control
- 4: auxiliary contact, closed when the switch is in position 0
- 5: auxiliary contact, closed when the switch is in position II
- 6: auxiliary contact, closed when the switch is in position I
- 7: power supply 12 VDC (9-15 VDC) or 24 VDC / 48 VDC (17-62 VDC) depending on the version.

ATyS S: 230 VAC

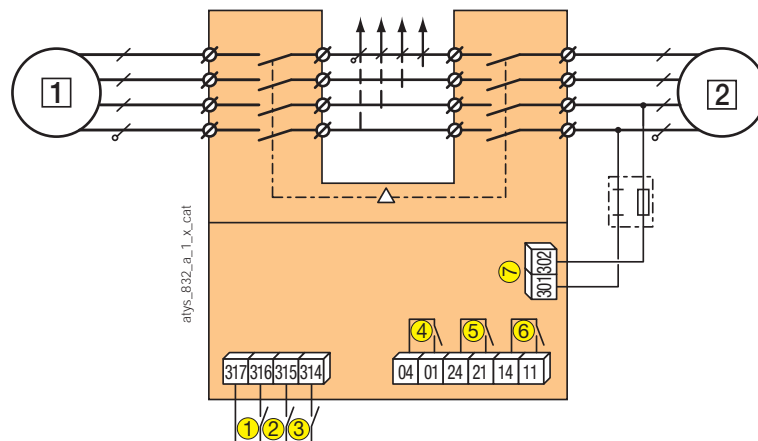

- 1 preferred source
- 2 alternate source
- 1: position 0 control
- 2: position I control
- 3: position II control
- 4: auxiliary contact, closed when the switch is in position 0
- 5: auxiliary contact, closed when the switch is in position II
- 6: auxiliary contact, closed when the switch is in position I
- 7: power supply kit: 230 VAC (160-310 VAC)

ATyS d S: 2 x 230 VAC

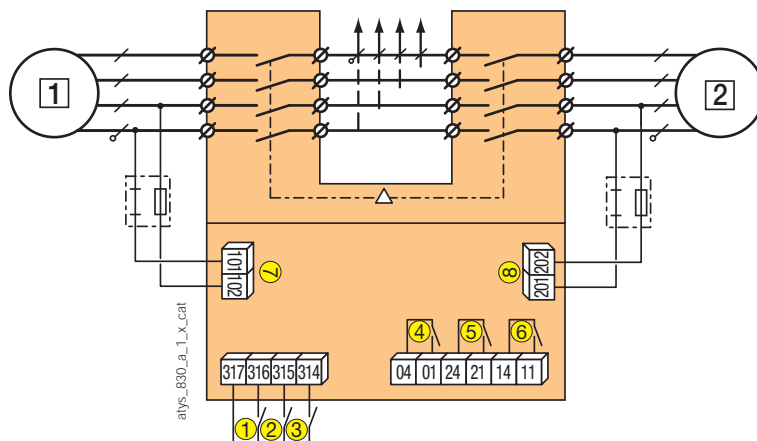

- 1 preferred source
- 2 alternate source
- 1: position 0 control
- 2: position I control
- 3: position II control
- 4: auxiliary contact, closed when the switch is in position 0
- 5: auxiliary contact, closed when the switch is in position II
- 6: auxiliary contact, closed when the switch is in position I
- 7: power supply kit I: 230 VAC (160-310 VAC)
- 8: power supply kit II: 230 VAC (160-310 VAC)

Dimensions

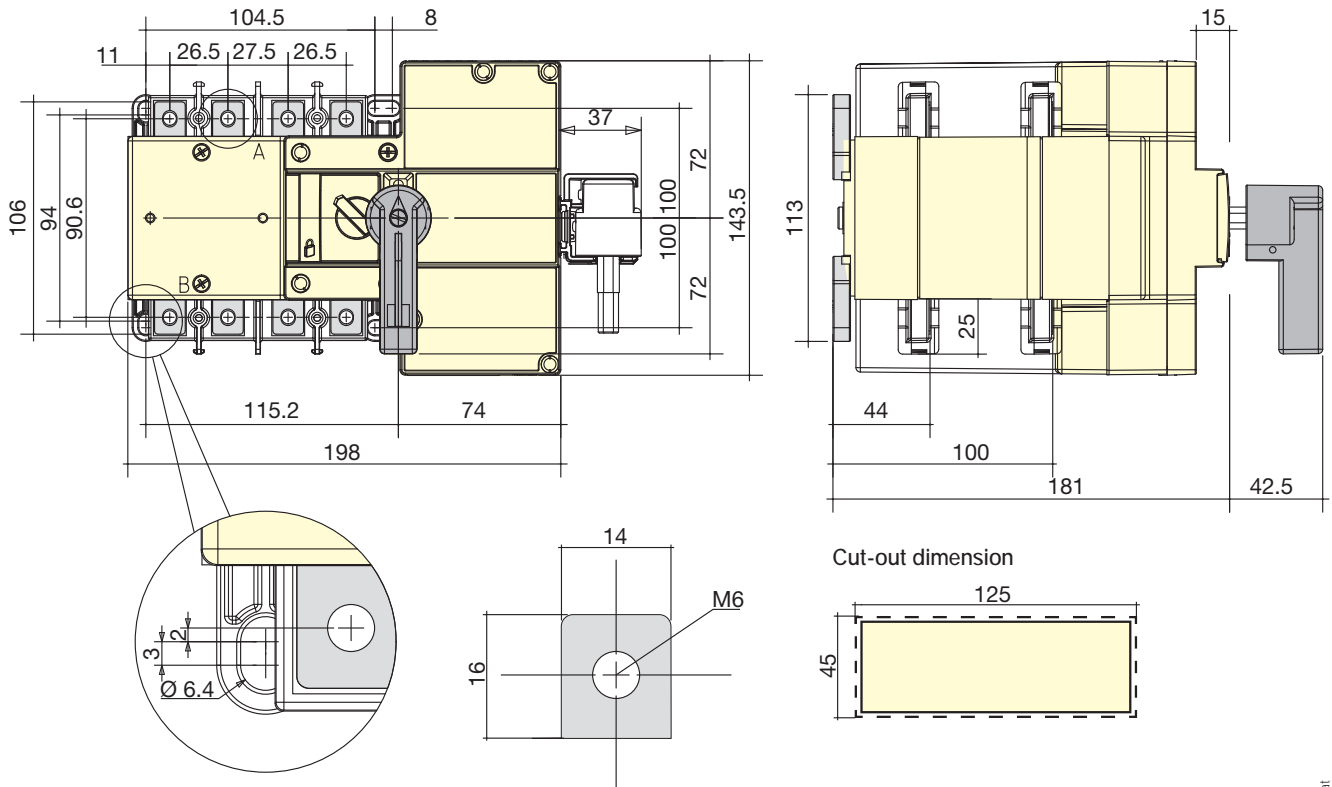

atys-s_024_a_1_x_cat

Connection terminal

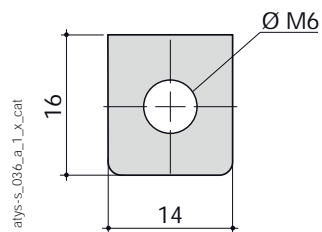

atys-s_036_a_1_x_cat

The **ATyS** range: intuitive, reliable and robust solutions

A complete range of automatic and remotely operated transfer switches from 125 to 3200 A

To meet the increasing demands of its users, the ATyS range is constantly evolving to offer new functions. Three product versions are available to find the right solution perfectly adapted to your application.

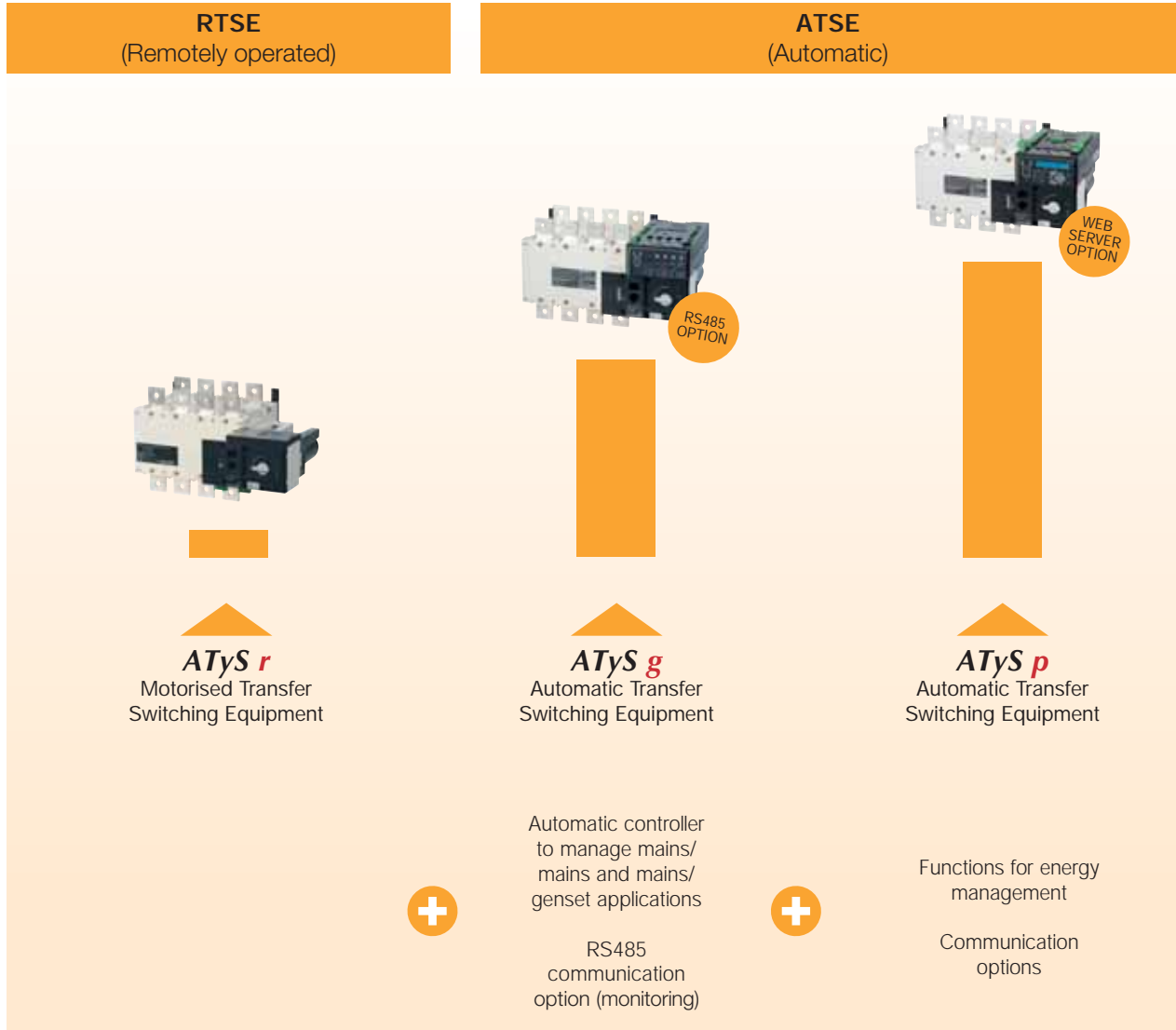

The **ATyS** range: intuitive, reliable and robust solutions

The advantages



Safe operation

- Permanent indication of product availability (Watchdog relay).
- Positive break indication.
- Mechanical position interlocking.
- Padlocked mode to secure maintenance operations (lockout).
- Secure access to the product configuration.



Robust integrated solution

A single product with all the functions:

- Integrated and tested solution: components factory assembled and wired.
- Greater reliability: compliance with IEC 60947-6-1, the standard governing transfer switches.

Proven SOCOMEC technology:

- Combination of two "back-to-back" (load break switch) PC class switches.
- Switching based on stable positions guaranteeing constant pressure on the contacts at all times.
- SIRCO contact technology used in numerous products for over 40 years.



Intuitive use

- Manual emergency control: The product can be controlled **quickly and safely** using an emergency handle (motor installed or removed).
- User friendly selection of the operating mode (Auto/Manual) using an integrated selector.



Rapid commissioning

- **ATyS**: no configuration required.
- **ATyS g**: configuration in just a few minutes using a screwdriver.
- **ATyS p**: simplified configuration (EASY CONFIG software and LCD display on the device).
- **ATyS g, p**: auto-configuration of the network parameters.



Easy maintenance

- Self-cleaning sliding contacts.
- Easy replacement of the motor and the electronic unit, even on-load.

Improved on load characteristics

IEC 60947-6-1/GB 14048-11

- AC 31B - up to 3200 A
- AC 32B - up to 2000 A
- AC 33B - up to 1250 A

IEC 60947-3

- AC 23B - up to 1250 A

Enclosed RTSE



See "Enclosed transfer switches".

Enclosed ATSE



See "Enclosed transfer switches".

Expert Services

- > Study, definition, advice, implementation, maintenance and training...
- > Our Expert Services team offers customised support to make your project a success.



ATyS r

Remotely operated Transfer Switching Equipment
from 125 to 3200 A



Function

ATyS r are 3 or 4 pole remotely operated motorised transfer switches with positive break indication.

They enable the on-load transfer of two three-phase power supplies via remote volt-free contacts, from either an external automatic controller, using pulse logic, or a switch.

They are intended for use in low voltage power systems where interruption of the load supply is acceptable during transfer.

Advantages

Watchdog relay to check product availability

ATyS r products are equipped with a Watchdog relay which constantly monitors your product, thereby securing the installation.

This relay informs in real time the user of the product's availability, i.e. whether it is operational and ready for source switching.

Integrated auxiliary contacts

As part of the product monitoring function, the ATyS r enable the transmission of information relating to their position. This is possible thanks to the standard integration of an auxiliary contact for each position.

Extended power supply range

ATyS r products offer greater availability thanks to their extensive power supply range of 208 to 277 VAC \pm 20%.

More robust

The updated design includes metal mounting legs across the entire ATyS range, improving the overall robustness of the switches.

It also allows an easier and trouble-free mounting of the switches on a back plate with preassembled screws.

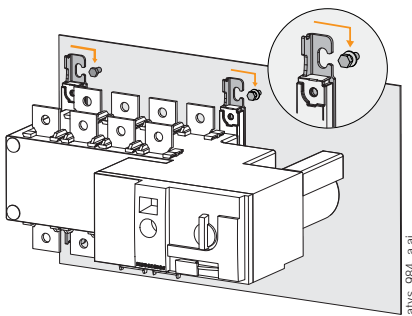

The solution for

- > Applications with an external ATS/AMF controller
- > Building Management Systems (BMS)



Strong points

- > Watchdog relay to check product availability
- > Integrated auxiliary contacts
- > Extended power supply range
- > Robust design

Conformity to standards

- > IEC 60947-6-1
- > IEC 60947-3
- > GB/T 14048.11



Approvals and certifications⁽¹⁾



BUREAU
VERITAS



⁽¹⁾ Product references on request.

Compatible with



ATyS C25, ATyS C35, ATyS C55, ATyS C65
ATS Controller

Enclosed RTSE



See "Enclosed transfer switches".

References

ATyS r

Rating (A) / Frame size	No. of poles	ATyS r	Bridging bars ⁽⁴⁾	Terminal shrouds	Terminal screens	Auxiliary contact	3 position padlocking	Auto transformer						
125 A / B3	3 P	9523 3012	4109 0019	3 P 2694 3014 ⁽²⁾ 4 P 2694 4014 ⁽²⁾	3 P 1509 3012 4 P 1509 4012									
	4 P	9523 4012												
160 A / B3	3 P	9523 3016												
	4 P	9523 4016												
200 A / B3	3 P	9523 3020												
	4 P	9523 4020												
250 A / B4	3 P	9523 3025							4109 0025	3 P 2694 3021 ⁽²⁾ 4 P 2694 4021 ⁽²⁾	3 P 1509 3025 4 P 1509 4025	1599 0502	9599 0003 ⁽³⁾	
	4 P	9523 4025												
315 A / B4	3 P	9523 3031							4109 0039					
	4 P	9523 4031												
400 A / B4	3 P	9523 3040												
	4 P	9523 4040												
500 A / B5	3 P	9523 3050	4109 0050											
	4 P	9523 4050												
630 A / B5	3 P	9523 3063	4109 0063	3 P 2694 3051 ⁽²⁾ 4 P 2694 4051 ⁽²⁾	3 P 1509 3063 4 P 1509 4063			400/230 VAC 1599 4064 ⁽⁵⁾						
	4 P	9523 4063												
800 A / B6	3 P	9523 3080	4109 0080		3 P 1509 3080 4 P 1509 4080	1599 0532								
	4 P	9523 4080												
1000 A / B6	3 P	9523 3100												
	4 P	9523 4100												
1250 A / B6	3 P	9523 3120							4109 0120					
	4 P	9523 4120												
1600 A / B7	3 P	9523 3160	4109 0160						3 P 1509 3160 4 P 1509 4160			9599 0004 ⁽³⁾		
	4 P	9523 4160												
2000 A / B8	3 P	9523 3200	(1)							3 P 1509 3200 4 P 1509 4200	included			
	4 P	9523 4200												
2500 A / B8	3 P	9523 3250												
	4 P	9523 4250												
3200 A / B8	3 P	9523 3320												
	4 P	9523 4320												

(1) See "Copper bar connection pieces".

(2) For complete shrouding at front, rear, top and bottom, order quantity 4; if equipped with bridging bars order quantity 3.

For top and bottom shrouding for the front only, order quantity 2.

(3) Factory mounting only.

(4) For a 3 pole device order quantity 3 bridging bars, for a 4 pole device order quantity 4.

(5) Order 1 auto transformer per source without neutral line conductor.

ATyS g

Automatic Transfer Switching Equipment
from 125 to 3200 A

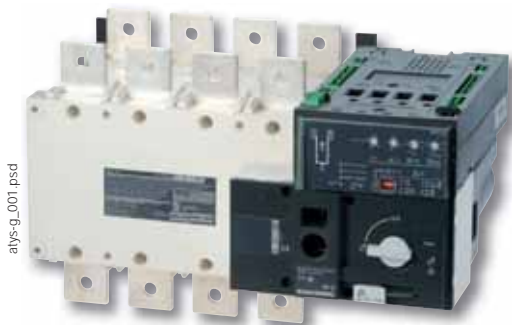

Function

ATyS g are 3 or 4 pole automatic transfer switches, with positive break indication. They incorporate all the functions offered by the ATyS r, as well as functions intended for **mains/mains** and **mains/genset** applications.

In automatic mode they enable the monitoring of, and the on-load changeover between, two power supply sources, in accordance with the parameters configured via potentiometers and DIP switches. Remote monitoring of the ATyS g is possible with the optional RS485 communication module.

They are intended for use in low voltage power supply systems where a brief interruption of the load supply is acceptable during transfer.

Advantages

Rapid commissioning

ATyS g switches offer significant time saving during commissioning (process takes 2 to 3 minutes). Owing to the design that allows commissioning through just four potentiometers and four DIP switches, a screwdriver is all that is required to configure the parameters.

For added simplicity, they also offer an autoconfiguration function which enables automatic adjustment of the rated voltage and frequency.

Specifically designed for mains/mains and mains/genset applications

The ATyS g's integrated controller has been designed to provide specific functions for these applications (genset startup, on-load or off-load tests...) together with the monitoring of the voltage and frequency of both sources for three-phase and single-phase networks.

The generator supply must be connected to switch II, located at the rear.

RS485 communication

An optional RS485 communication module (p/n 4825 0092) can be fitted to the ATyS g controller.

It allows remote monitoring of available power sources and their parameters, timers, as well as displaying the product's status and configuration.

Communication speed is up to 38400 bauds.

The solution for

- > Mains/mains and mains/genset applications



Strong points

- > Rapid commissioning
- > ATS with integrated DPS and controller for functions dedicated to mains/mains or mains/genset applications

Conformity to standards

- > IEC 60947-6-1
- > IEC 60947-3
- > GB/T 14048.11



Approvals and certifications⁽¹⁾



BUREAU
VERITAS



⁽¹⁾ Product references on request.

Enclosed RTSE



See "Enclosed transfer switches".

References

ATyS g

Rating (A) / Frame size	No. of poles	ATyS g	Bridging bars ⁽³⁾	Voltage sensing and power supply kit	Terminal shrouds	Terminal screens	Auxiliary contact					
125 A / B3	3 P	9553 3012	4109 0019	3 P 1559 3012 4 P 1559 4012	3 P 2694 3014 ⁽²⁾ 4 P 2694 4014 ⁽²⁾	3 P 1509 3012 4 P 1509 4012	1599 0502					
	4 P	9553 4012										
160 A / B3	3 P	9553 3016										
	4 P	9553 4016										
200 A / B3	3 P	9553 3020										
	4 P	9553 4020										
250 A / B4	3 P	9553 3025						4109 0025	1559 3025	3 P 2694 3021 ⁽²⁾ 4 P 2694 4021 ⁽²⁾	3 P 1509 3025 4 P 1509 4025	1599 0502
	4 P	9553 4025							1559 4025			
315 A / B4	3 P	9553 3031	4109 0039	3 P 1559 3040 4 P 1559 4040								
	4 P	9553 4031										
400 A / B4	3 P	9553 3040										
	4 P	9553 4040										
500 A / B5	3 P	9553 3050	4109 0050	3 P 1559 3063 4 P 1559 4063	3 P 2694 3051 ⁽²⁾ 4 P 2694 4051 ⁽²⁾	3 P 1509 3063 4 P 1509 4063	1599 0532					
	4 P	9553 4050										
630 A / B5	3 P	9553 3063	4109 0063									
	4 P	9553 4063										
800 A / B6	3 P	9553 3080	4109 0080	3 P 1559 3080 4 P 1559 4080								
	4 P	9553 4080										
1000 A / B6	3 P	9553 3100										
	4 P	9553 4100										
1250 A / B6	3 P	9553 3120	4109 0120	1559 3120								
	4 P	9553 4120		1559 4120								
1600 A / B7	3 P	9553 3160	4109 0160	1559 3160	1509 3160							
	4 P	9553 4160		1559 4160	1509 4160							
2000 A / B8	3 P	9553 3200	(1)	3 P 1559 3200 4 P 1559 4200	3 P 1509 3200 4 P 1509 4200	included						
	4 P	9553 4200										
2500 A / B8	3 P	9553 3250										
	4 P	9553 4250										
3200 A / B8	3 P	9553 3320										
	4 P	9553 4320										

(1) See "Copper bar connection pieces".

(2) For complete shrouding at front, rear, top and bottom, order quantity 4; if equipped with bridging bars order quantity 3. For top and bottom shrouding for the front only, order quantity 2.

(3) For a 3 pole device order quantity 3 bridging bars, for a 4 pole device order quantity 4.

ATyS p

Automatic Transfer Switching Equipment
from 125 to 3200 A



The solution for

- > Applications requiring power management and communication.



Strong points

- > Optional communication modules
- > Recording of events
- > Configuration software
- > Power measurements
- > Possibility to set periodic genset startup

Conformity to standards

- > IEC 60947-6-1
- > IEC 60947-3
- > GB/T 14048.11



Approvals and certifications⁽¹⁾



BUREAU
VERITAS



⁽¹⁾ Product references on request.

Webserver

The Webserver function comprises HTML pages embedded in the Ethernet communication module.

These pages can be accessed via an internet browser, simply by entering the IP address.

The webserver offers the following functionalities:

- > Display of source status and switch position
- > Display of the main measurements
- > Extraction of the latest logged events
- > Display of the product configuration

Function

ATyS p are 3 or 4 pole automatic transfer switches with positive break indication. They incorporate all the functions offered by the ATyS t and g, as well as functions designed for **power management and functions communication**.

In automatic mode they enable the monitoring of, and the on-load changeover between, two power supply sources, in accordance with the parameters configured through LCD display, or via communication.

They are intended for use in low voltage power supply systems where a brief interruption of the load supply is acceptable during transfer.

Advantages

Recording of events

ATyS p switches enable effective monitoring of your installation thanks to timestamped event recording.

Events can be retrieved and read via communication.

Optional communication modules

The ATyS p offers communication functions through the addition of optional modules, such as RS485 Modbus or Ethernet with embedded Webserver.

Configuration software

Software (Easyconfig) is available enabling the ATyS p parameters to be easily configured and the existing configuration to be saved and sent to other units.

Power measurements

ATyS p products are particularly suited to energy management and monitoring.

In addition to their integrated power and energy measurement functions (with a 2% accuracy level), programmable inputs/outputs can be utilised to control load shedding based on a load level or tariff.

Possibility to set periodic genset startup

ATyS p switches offer additional functions for maintenance. They include a programmable genset starting function which allows the starting dates and operating times to be configured.

Front panel

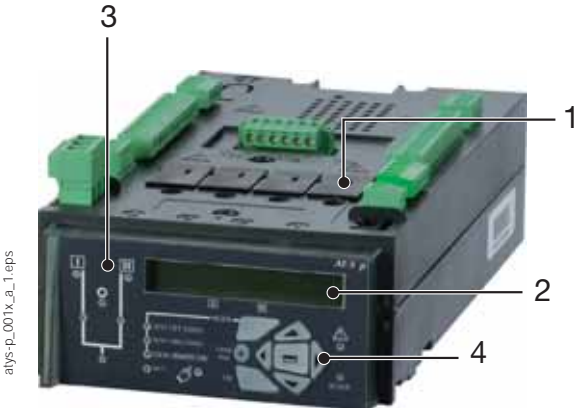

1. Slots for optional plug-in modules.
2. Backlit LCD display.
3. Source availability and position indication LEDs.
4. Parameter programming keypad.

Communication and configuration

Easyconfig

Easyconfig software is the ideal solution to save time and simplify complex configuration.

Allows configuration of the following parameters:

- application type,
- voltage/frequency thresholds,
- timers,
- inputs/outputs...



Webserver

Thanks to optional modules, ATyS p can communicate in **Modbus** and **Ethernet** protocols.

The Ethernet communication module includes the **Webserver** function for access to the ATySp via an internet browser.

The Webserver function enables:

- display of source status and switch position,
- display of voltage measurements,
- display of parameters,
- access to the list of logged events.



References

ATyS p

Rating (A) / Frame size	No. of poles	ATyS p	Bridging bars ⁽³⁾	Voltage sensing and power supply kit	Terminal shrouds	Terminal screens	Optional modules	Auxiliary contact						
125 A / B3	3 P	9573 3012	4109 0019	3 P 1559 3012 4 P 1559 4012	3 P 2694 3014 ⁽²⁾ 4 P 2694 4014 ⁽²⁾	3 P 1509 3012 4 P 1509 4012								
	4 P	9573 4012												
160 A / B3	3 P	9573 3016												
	4 P	9573 4016												
200 A / B3	3 P	9573 3020												
	4 P	9573 4020												
250 A / B4	3 P	9573 3025							4109 0025	1559 3025	3 P 2694 3021 ⁽²⁾ 4 P 2694 4021 ⁽²⁾	3 P 1509 3025 4 P 1509 4025	RS485 MODBUS communication 4825 0092	1599 0502
	4 P	9573 4025								1559 4025				
315 A / B4	3 P	9573 3031	4109 0039	3 P 1559 3040 4 P 1559 4040										
	4 P	9573 4031												
400 A / B4	3 P	9573 3040												
	4 P	9573 4040												
500 A / B5	3 P	9573 3050	4109 0050	3 P 1559 3063 4 P 1559 4063	3 P 2694 3051 ⁽²⁾ 4 P 2694 4051 ⁽²⁾	3 P 1509 3063 4 P 1509 4063	2 inputs / 2 outputs 1599 2001							
	4 P	9573 4050												
630 A / B5	3 P	9573 3063	4109 0063	3 P 1559 3080 4 P 1559 4080			Ethernet communication 4825 0203							
	4 P	9573 4063												
800 A / B6	3 P	9573 3080	4109 0080	3 P 1559 3080 4 P 1559 4080		3 P 1509 3080 4 P 1509 4080	Ethernet communication + RS485 MODBUS gateway 4825 0204							
	4 P	9573 4080												
1000 A / B6	3 P	9573 3100												
	4 P	9573 4100												
1250 A / B6	3 P	9573 3120	4109 0120	3 P 1559 3120 4 P 1559 4120			Analogue outputs 4825 0093	1599 0532						
	4 P	9573 4120												
1600 A / B7	3 P	9573 3160	4109 0160	3 P 1559 3160 4 P 1559 4160		1509 3160	Pulse outputs 4825 0090							
	4 P	9573 4160				1509 4160								
2000 A / B8	3 P	9573 3200	(1)	3 P 1559 3200 4 P 1559 4200		3 P 1509 3200 4 P 1509 4200		included						
	4 P	9573 4200												
2500 A / B8	3 P	9573 3250												
	4 P	9573 4250												
3200 A / B8	3 P	9573 3320												
	4 P	9573 4320												

(1) See "Copper bar connection pieces".

(2) For complete shrouding at front, rear, top and bottom, order quantity 4; if equipped with bridging bars order quantity 3. For top and bottom shrouding for the front only, order quantity 2.

(3) For a 3 pole device order quantity 3 bridging bars; for a 4 pole device order quantity 4.

ATyS p

Rating (A) / Frame size	No. of poles	ATyS p	DC power supply	3 position padlocking	Key handle interlocking system	Door protective surround	Remote control interface
125 A / B3	3 P	9573 3012	12 VDC/230 VAC 1599 5012 24 VDC/230 VAC 1599 5112 48 VDC/230 VAC 1599 5212	9599 0003 ⁽¹⁾	Using lock RONIS EL11AP in position 0 9599 1006 ⁽¹⁾	1539 0012	D20 9599 2020 + RJ45 cable connection 1599 2009
	4 P	9573 4012					
160 A / B3	3 P	9573 3016					
	4 P	9573 4016					
200 A / B3	3 P	9573 3020					
	4 P	9573 4020					
250 A / B4	3 P	9573 3025					
	4 P	9573 4025					
315 A / B4	3 P	9573 3031					
	4 P	9573 4031					
400 A / B4	3 P	9573 3040					
	4 P	9573 4040					
500 A / B5	3 P	9573 3050					
	4 P	9573 4050					
630 A / B5	3 P	9573 3063					
	4 P	9573 4063					
800 A / B6	3 P	9573 3080					
	4 P	9573 4080					
1000 A / B6	3 P	9573 3100					
	4 P	9573 4100					
1250 A / B6	3 P	9573 3120					
	4 P	9573 4120					
1600 A / B7	3 P	9573 3160					
	4 P	9573 4160					
2000 A / B8	3 P	9573 3200					
	4 P	9573 4200					
2500 A / B8	3 P	9573 3250					
	4 P	9573 4250					
3200 A / B8	3 P	9573 3320					
	4 P	9573 4320					
				9599 0004 ⁽¹⁾	Using lock RONIS EL11AP in position 0 9599 1004 ⁽¹⁾	1539 0080	

(1) Factory mounting only.

ATyS range

ATyS *r*, ATyS *g*, ATyS *p*
from 125 to 3200 A

Accessories

Terminal shrouds

Use

IP2X protection against direct contact with terminals or connecting parts.

Advantages

Perforations allow remote thermographic inspection without the need to remove the shrouds.

Rating (A)	Frame size	No. of poles	Position	Reference
125 ... 200	B3	3 P	top / bottom / front (I) / rear (II)	2694 3014 ⁽¹⁾⁽²⁾
125 ... 200	B3	4 P	top / bottom / front (I) / rear (II)	2694 4014 ⁽¹⁾⁽²⁾
250 ... 400	B4	3 P	top / bottom / front (I) / rear (II)	2694 3021 ⁽¹⁾⁽²⁾
250 ... 400	B4	4 P	top / bottom / front (I) / rear (II)	2694 4021 ⁽¹⁾⁽²⁾
500 ... 630	B5	3 P	top / bottom / front (I) / rear (II)	2694 3051 ⁽¹⁾⁽²⁾
500 ... 630	B5	4 P	top / bottom / front (I) / rear (II)	2694 4051 ⁽¹⁾⁽²⁾

(1) For complete shrouding at front, rear, top and bottom, order quantity 4; if equipped with bridging bars order quantity 3.
(2) For top and bottom shrouding for the front only, order quantity 2.



access_206_a_2_cat

Terminal screens

Use

Upstream and downstream protection against direct contact with terminals or connection parts.
For upstream and downstream protection, order quantity 1.

Rating (A)	Frame size	No. of poles	Position	Reference
125 ... 200	B3	3 P	top / bottom	1509 3012
125 ... 200	B3	4 P	top / bottom	1509 4012
250 ... 400	B4	3 P	top / bottom	1509 3025
250 ... 400	B4	4 P	top / bottom	1509 4025
500 ... 630	B5	3 P	top / bottom	1509 3063
500 ... 630	B5	4 P	top / bottom	1509 4063
800 ... 1250	B6	3 P	top / bottom	1509 3080
800 ... 1250	B6	4 P	top / bottom	1509 4080
1600	B7	3 P	top / bottom	1509 3160
1600	B7	4 P	top / bottom	1509 4160
2000 ... 3200	B8	3 P	top / bottom	1509 3200
2000 ... 3200	B8	4 P	top / bottom	1509 4200



access_207_a_2_cat

Inter-phase barrier

Use

Safe isolation between the terminals, essential for use at 690 VAC or in a polluted or dusty atmosphere.

Rating (A)	Frame size	No. of poles	Reference
125 ... 200	B3	3 P	2998 0033
125 ... 200	B3	4 P	2998 0034
250 ... 400	B4	3 P	2998 0023
250 ... 400	B4	4 P	2998 0024
500 ... 630	B5	3 P	2998 0013
500 ... 630	B5	4 P	2998 0014
800 ... 3200	B6 ... B8	3/4 P	included

Bridging bars

Use

For bridging power terminals on the outgoing side of the switch.

Rating (A)	Frame size	Diameter (mm)	Reference ⁽¹⁾
125 ... 200	B3	20 x 2.5	4109 0019
250	B4	25 x 2.5	4109 0025
315 ... 400	B4	32 x 5	4109 0039
500	B5	32 x 5	4109 0050
630	B5	50 x 5	4109 0063
800 ... 1000	B6	50 x 6	4109 0080
1250	B6	60 x 8	4109 0120
1600	B7	90 x 10	4109 0160

(1) For a 3 pole device order quantity 3 bridging bars, for a 4 pole device order quantity 4.



access_205_a_2_cat

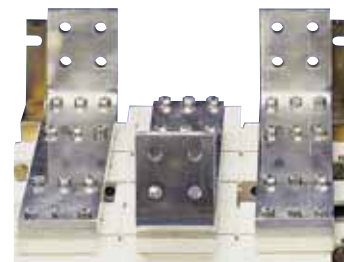

access_041_a_1_cat

Copper bar connection pieces

Use

For ratings 2000 to 3200 A.

Enables:

- Flat connection: the connection pieces provide a link between the two power terminals of the same pole (Fig. 1).
- Edgewise connection: the connection pieces provide a link between the two power terminals of the same pole and an edgewise bar connection terminal.
- Top or bottom bridging between two poles (Fig. 3).

Once installed, the power terminal is connection ready.

For 3200 A rating, connection pieces (part A) are supplied as standard. Bolt sets must be ordered separately.

Connection: the quantities given in the below table refer to the number of pieces required per pole, top or bottom.

Bridging connection: the quantities given refer to the number of pieces required to complete a single bridging connection between two poles.

	Reference	2000 – 2500 A			3200 A		
		Fig. 1	Fig. 2	Fig. 3	Fig. 1	Fig. 2	Fig. 3
		Connection		Bridging connection I - II	Connection		Bridging connection I - II
Connection - part A	2619 1200	1	1	2 ⁽²⁾	included	included	included
Bolt kit 35 mm - part B	2699 1201	1 ⁽¹⁾		2 ⁽²⁾	1 ⁽¹⁾		2 ⁽²⁾
Bolt kit 45 mm - part B	2699 1200	1 ⁽¹⁾			1 ⁽¹⁾		
T + Bolt kit - part C	2629 1200		1	1		1	1
Bracket + bolt kit - part D	2639 1200		1			1	
Bar + bolt kit - part E	4109 0320			1			1

(1) Choose the bolt length according to the thickness of the bars being connected; if bar thickness is greater than 20 mm, 45 mm bolts are required.

(2) For bridging connections, quantity 2 pieces are required for creating the link between the two power terminals of the same pole for switch bodies I and II.

The quantities of the applicable pieces then need to be multiplied by the number of connection points (power terminals) in order to determine the total quantity required of each part.

Example: For a 4 pole 2500 A SIRCOVER with upstream edgewise connection (Fig. 2) and downstream bridging (Fig. 3), the following quantities will be required:

Part	Upstream edgewise quantity	Downstream bridging quantity	Total quantity
A	8	8	16
B	0	8	8
C	8	4	12
D	8	0	8
E	0	4	4

Fig. 1

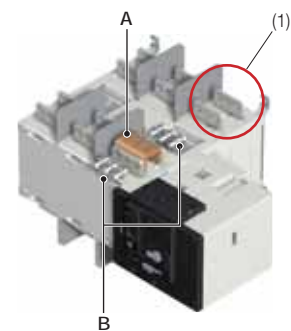

access_459_a_1_x_cat

(1) Single pole connection: 1 pole (top or bottom) comprises two power terminals which are to be linked with the copper connection kit.

Fig. 2

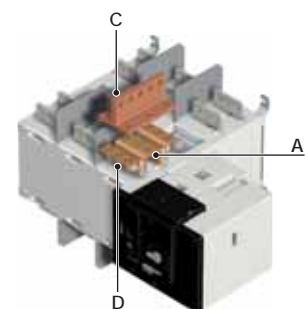

access_460_a_1_x_cat

Fig. 3

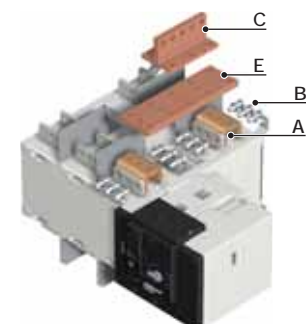

access_461_a_1_x_cat

ATyS range

ATyS r, ATyS g, ATyS p
from 125 to 3200 A

Accessories (continued)

Autotransformer

Use

For applications without neutral, this autotransformer provides the 230 VAC required to power these ATyS products.

Specified protection for the autotransformer:

- Protection of the primary:
fuse holder ref 57010020 + fuse ref 60130000
- Protection of the secondary:
fuse holder ref 57010015 + fuse ref 60130001.

Rating (A)	Frame size	Reference
125 ... 3200	B3 ... B8	1599 4064

DC power supply

Use

Allows an ATyS to be supplied from a 12 or 24 VDC source. To be positioned as close as possible to the DC power supply source.

Rating (A)	Frame size	Operating voltage	Reference
125 ... 1600	B3 ... B7	24 VDC / 230 VAC	1599 5112

Voltage sensing and power supply kit

Use

For power supply and voltage measurement (4 wire, three-phase) for the ATyS g and p. Routing of the conductors is controlled, which means that no specific protective device is necessary for these connections.

The kit can be fitted on the top or bottom of the switch.

Note: the 3-pole version does not integrate the power supply.

125 to 630 A kit

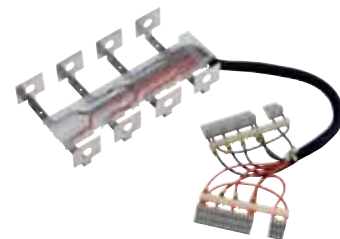

atys_606_a_1_cat

800 to 3200 A kit



atys_603_a_2_cat

For ATyS g and ATyS p - 3 pole

Rating (A)	Frame size	Reference
125 ... 200	B3	1559 3012
250	B4	1559 3025
315 ... 400	B4	1559 3040
500 ... 630	B5	1559 3063
800 ... 1000	B6	1559 3080
1250	B6	1559 3120
1600	B7	1559 3160
2000 ... 3200	B8	1559 3200

For ATyS g and ATyS p - 4 pole

Rating (A)	Frame size	Reference
125 ... 200	B3	1559 4012
250	B4	1559 4025
315 ... 400	B4	1559 4040
500 ... 630	B5	1559 4063
800 ... 1000	B6	1559 4080
1250	B6	1559 4120
1600	B7	1559 4160
2000 ... 3200	B8	1559 4200

Voltage sensing tags

Use

For use with ATyS r, g and p, the voltage sensing tags allow voltage to be tapped directly off of ATyS power terminals to provide a supply to, for example, a control circuit or source presence indicator lamps.

Voltage sensing tags are equipped with a Faston connector and can be mounted on the top or bottom side of the transfer switch.

With ATyS r, this accessory allows easy connection to an ATyS C25 / C35 controller via the ATyS C25 cable harness.

1 pack contains 8 voltage sensing tags.

Voltage sensing tags are integrated on ATyS $\geq 800A$.

Rating (A)	Frame size	Reference
125 ... 200	B3	9599 4020
250 ... 400	B4	9599 4040
500 ... 630	B5	9599 4063

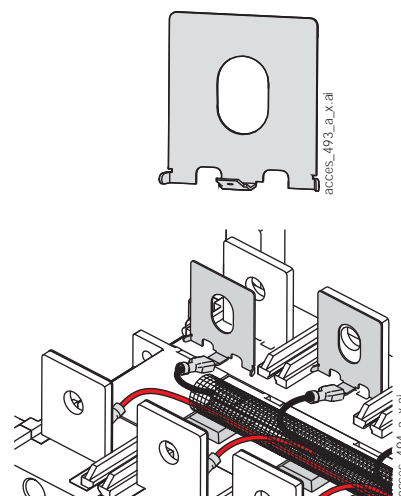

ATyS C25 / C35 cable harness

Use

The ATyS C25 / C35 cable harness is a fast and reliable solution for connecting an ATyS r transfer switch to a C25 / C35 controller in order to create an Automatic Transfer Switch. It is equipped with Faston voltage tap-offs and provides a safe connection between the controller and changeover switch for:

- monitoring availability of the incoming power sources,
- monitoring changeover switch status,
- providing an electrical interlock function,
- automatic control and transfer between power sources.

Provides a DPS auxiliary supply to the ATyS r. Cable harness length is approximately 2 metres.

The cable harness is for use with 4 pole ATyS r only and requires neutral conductors to be on the right side of the transfer switch.

For ATyS r $\leq 630A$ it is necessary to order voltage sensing tags separately (required for voltage tap-off connections).

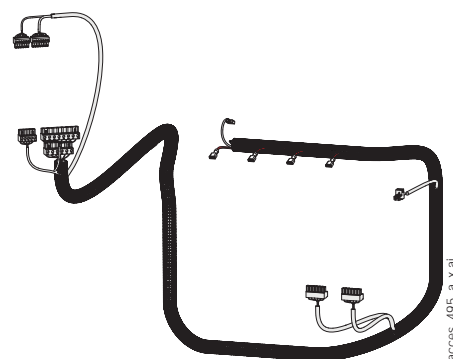

For ATyS r connection to a C25 / C35 controller		
Rating (A)	Frame size	Reference
125 ... 630	B3 ... B5	9529 4063
800 ... 3250	B6 ... B8	9529 4080

ATyS range

ATyS r, ATyS g, ATyS p
from 125 to 3200 A

Accessories (continued)

Voltage relay

Use

The DS is a voltage relay for monitoring a single power supply.

If it detects a fault in the source, the fault relay contact closes.



atys_762_a_1_cat

Rating (A)	Reference
DS	192X 0056

Door protective surround

Use

Door surround to provide a clean and safe finish to the panel's cut-out.

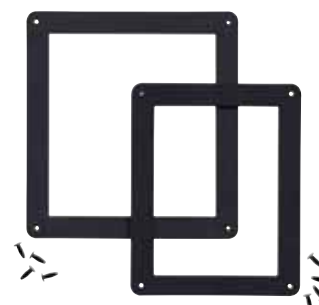

atys_595_a_2_cat

For ATyS		
Rating (A)	Frame size	Reference
125 ... 630	B3 ... B5	1529 0012
800 ... 3200	B6 ... B8	1529 0080

For ATyS g and p		
Rating (A)	Frame size	Reference
125 ... 630	B3 ... B5	1539 0012
800 ... 3200	B6 ... B8	1539 0080

Auxiliary contact

Use

Pre-break and signalling of positions I and II: each reference provides 1 NO/NC auxiliary contact for positions I and II. Possibility to install up to 2 auxiliary contacts for each position. Suitable for use as a 1st or 2nd auxiliary contact.

Low level AC: contact us. ATyS are supplied with 1 NO aux contact for all three positions as standard which are located in the motor unit.



800 to 1600 A

access_396_a

If additional auxiliary contacts are required please consult us.

Rating (A)	Frame size	Nominal current (A)	Operating current I _e (A)			
			250 VAC AC-13	400 VAC AC-13	24 VDC DC-13	48 VDC DC-13
125 ... 3200	B3 ... B8	16	12	8	14	6

Rating (A)	Frame size	Type of mounting	Reference
125 ... 630	B3 ... B5	Customer fit	1599 0502
800 ... 1600	B6 ... B7	Customer fit	1599 0532
2000 ... 3200	B8	-	2 AC per position fitted as standard



125 to 630 A

access_397_a

3 position padlocking (I - 0 - II)

Use

Enables the product to be padlocked in positions 0, I and II (factory fitted).



atys_867_a

Rating (A)	Frame size	Reference
125 ... 630	B3 ... B5	9599 0003
800 ... 3200	B6 ... B8	9599 0004

Key handle interlocking system

Use

With the product in manual mode, it enables locking in position 0 using a RONIS EL11AP lock (factory fitted). As standard, locking in position 0. With the 3 position padlocking accessory: key interlocking in I, 0 & II.

Locks (key N° random) :

- RONIS EL11AP ref 4409 8511
- TRAYVOU XOP10 ref 4409 8601



atys_868_a

Rating (A)	Frame size	Reference
125 ... 630	B3 ... B5	9599 1006
800 ... 3200	B6 ... B8	9599 1004

Current transformer

Use - for ATyS p only

Used with ATyS p units, these current transformers enable information to be obtained on the load current.

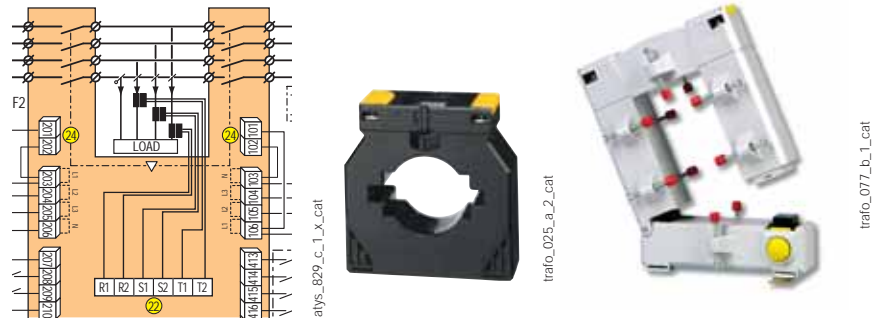

Plug-in optional modules

Use - for ATyS g and ATyS p

Number of modules per device

ATyS g: Compatible with RS485 JBUS/MODBUS module only. One module maximum can be installed (can be fitted in any slot).

ATyS p: A maximum of four modules can be fitted. With Ethernet communication module installation, only 2 additional modules can be fitted.

RS485 JBUS / MODBUS® communication

- RS485 link with JBUS / MODBUS® protocol (speed up to 38400 bauds).

2 inputs - 2 outputs

- 2 inputs and 2 outputs (programmable) on each module.

Ethernet communication

- Ethernet link with MODBUS/TCP or JBUS/MODBUS RTU over TCP.
- Embedded Ethernet Webserver software.

Ethernet communication with RS485 JBUS/MODBUS gateway

- Ethernet link with MODBUS/TCP or JBUS/MODBUS RTU over TCP.
- Connect 1 to 247 RS485 JBUS/MODBUS slaves.
- Embedded Ethernet Webserver software.

Analogue outputs

- Allocate outputs to: 3I, In, 3V, 3U, F, ± ΣP, ± ΣQ, ΣS.

Pulse outputs

- 2 configurable pulse outputs (type, weight and duration) on ±kWh, ±kvarh and kVAh.

Description of accessories	Suitable for	Reference
RS485 MODBUS communication	ATyS g & p	4825 0092
2 inputs - 2 outputs	ATyS p	1599 2001
Ethernet communication (embedded Ethernet Webserver software)	ATyS p	4825 0203
Ethernet communication + RS485 JBUS/MODBUS gateway (embedded Ethernet Webserver software)	ATyS p	4825 0204
Analogue outputs	ATyS p	4825 0093
Pulse outputs	ATyS p	4825 0090

ATyS range

ATyS r, ATyS g, ATyS p
from 125 to 3200 A

Accessories (continued)

Remote interfaces

Use

To remotely display source availability and position indication typically used on the front of a panel when the product is enclosed. Interfaces are powered from the ATyS transfer switch via the RJ45 connection cable.

Maximum cable length: 3 m.

D10 - for ATyS g

To display source availability and position indication on the front panel of an enclosure. Protection degree: IP21

D20 - for ATyS p

In addition to the functions of the D10, the D20 displays measurements and enables control and configuration from the front of a panel.

Protection degree: IP21

Door mounting

2 holes Ø 22.5.

ATyS transfer switch via RJ45 cable, not isolated. Cable available as an accessory.



atys_564_d_1_cat

atys_565_d_1_cat



atys_597_a_1_cat

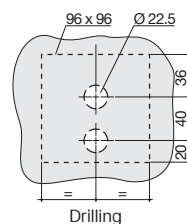

atys_161_a_1_x_cat

RJ45 port to connect to ATyS.

Drilling

Description of accessories	Suitable for	Reference
D10	ATyS g	9599 2010
D20	ATyS p	9599 2020

Connecting cable for remote interfaces

Use

To connect between a remote interface (type D10 or D20) and a control product (ATyS g or p).

Characteristics

RJ45 8 straight-through, non insulated cables, length 3 m.



aces_209_a_2_cat

For ATyS g and p		
Type	Length	Reference
RJ45 cable	3 m	1599 2009

Sealable cover

Use - for ATyS g

Prevents access to the configuration of ATyS g devices (seals supplied).

Rating (A)	Frame size	Reference
125 ... 3200	B3 ... B8	9599 0000



atys_870_a

Auto/Manual key selector

Use

Replaces the standard Auto/Manual selector knob with a key selector.

Rating (A)	Frame size	Reference
125 ... 3200	B3 ... B8	9599 1007



atys_869_a

Double power supply - DPS

Use

Allows an ATyS r to be supplied by two 230 VAC, 50/60 Hz networks.

	ATyS DPS	Modular DPS
Voltage (VAC)		
Min	166	200
Max	332	288
Current (A)		
Max Output	15	3.15
Connection (mm²)		
Max	2.5	6

Description	Suitable for ATyS r	Reference
Modular DPS	125 ... 1600 A	1599 4001
ATyS DPS	125 ... 3200 A	9539 2001

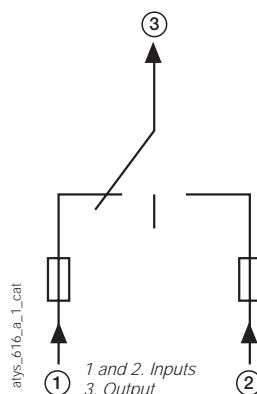

atys_616_a_1_cat



atys_612_a_2_cat



atys-d_001_psd

Spares

ATyS p front panel

This front panel is used, for the ATyS p only, if source 2 is connected to unit I and source 1 is connected to unit II. Positions I and II are reversed on the front panel.

Product model	Reference
ATyS p	9599 1008

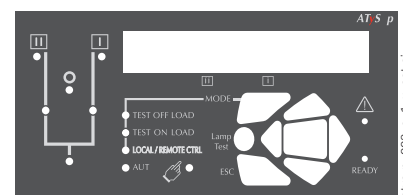

atys-p_002_a_1_x_cat.ai

Electronic module - controller

The electrical components of the ATyS g and p are easy to replace in case there is a problem, even when on-load.

Product model	Reference
ATyS g	9559 2001
ATyS p	9579 2001



atys-p_001_b

Motorisation module

The motor units of the ATyS r, g and p are easy to replace in case there is a problem, even when on-load.

Rating (A)	Reference
125 ... 200	9509 5020
250 ... 400	9509 5040
500 ... 630	9509 5063
800 ... 1250	9509 5120
1600	9509 5160
2000 ... 3200	9509 5320



atys_b71_a

Switching module

If you need to replace just the switching part on an ATyS r, g or p, order SIRCOVER items. Please refer to "SIRCOVER" pages.



svr_151_a

Characteristics according to IEC 60947-3 and IEC 60947-6-1

125 to 630 A

Thermal current I_{th} to 40°C	125 A	160 A	200 A	250 A	315 A	400 A	500 A	630 A		
Frame size	B3	B3	B3	B4	B4	B4	B5	B5		
Rated insulation voltage U_i (V) (power circuit)	800	800	800	1000	1000	1000	1000	1000		
Rated impulse withstand voltage U_{imp} (kV) (power circuit)	8	8	8	12	12	12	12	12		
Rated insulation voltage U_i (V) (control circuit)	300	300	300	300	300	300	300	300		
Rated impulse withstand voltage U_{imp} (kV) (control circuit)	4	4	4	4	4	4	4	4		
Rated operational currents I_e (A) according to IEC 60947-6-1										
Rated voltage	Utilisation category									
415 VAC	AC-31 B		125	160	200	250	315	400	500	630
415 VAC	AC-32 B					200	315	400	500	500
415 VAC	AC-33 B					200	200	200	400	400
Rated operational currents I_e (A) according to IEC 60947-3										
Rated voltage	Utilisation category	A/B⁽¹⁾	A/B⁽¹⁾	A/B⁽¹⁾	A/B⁽¹⁾	A/B⁽¹⁾	A/B⁽¹⁾	A/B⁽¹⁾	A/B⁽¹⁾	
415 VAC	AC-21 A / AC-21 B	125/125	160/160	200/200	250/250	315/315	400/400	500/500	630/630	
415 VAC	AC-22 A / AC-22 B	125/125	160/160	200/200	250/250	315/315	400/400	500/500	630/630	
415 VAC	AC-23 A / AC-23 B	125/125	160/160	200/200	200/200	315/315	400/400	500/500	500/630	
500 VAC	AC-21 A / AC-21 B	125/125	160/160	200/200	250/250	315/315	400/400	500/500	630/630	
500 VAC	AC-22 A / AC-22 B	125/125	160/160	200/200	200/250	200/315	200/400	500/500	500/500	
500 VAC	AC-23 A / AC-23 B	80/80	80/80	80/80	200/200	200/200	200/200	400/400	400/400	
690 VAC ⁽³⁾	AC-21 A / AC-21 B	125/125	160/160	200/200	200/200	200/200	200/200	500/500	500/500	
690 VAC ⁽³⁾	AC-22 A / AC-22 B	125/125	125/125	125/125	160/160	160/160	160/160	400/400	400/400	
690 VAC ⁽³⁾	AC-23 A / AC-23 B	63/80	63/80	63/80	125/125	125/125	125/125	400/400	400/400	
220 VDC	DC-21 A / DC-21 B	125/125	160/160	200/200	250/250	250/250	250/250	500/500	630/630	
220 VDC	DC-22 A / DC-22 B	125/125	160/160	200/200	250/250	250/250	250/250	500/500	630/630	
220 VDC	DC-23 A / DC-23 B	125/125	125/125	125/125	200/200	200/200	200/200	500/500	630/630	
440 VDC ⁽²⁾	DC-21 A / DC-21 B	125/125	125/125	125/125	200/200	200/200	200/200	500/500	630/630	
440 VDC ⁽²⁾	DC-22 A / DC-22 B	125/125	125/125	125/125	200/200	200/200	200/200	500/500	630/630	
440 VDC ⁽²⁾	DC-23 A / DC-23 B	125/125	125/125	125/125	200/200	200/200	200/200	500/500	630/630	
Current rated as conditional short-circuit with fuse gG DIN, according to IEC 60947-3										
Prospective fuse protected short-circuit withstand at 415 VAC ⁽⁶⁾	100	100	50	50	50	50	50	50		
Prospective fuse protected short-circuit withstand at 690 VAC(kA rms)				50	50	50	50	50		
Associated fuse rating (A)	125	160	200	250	315	400	500	630		
Short-circuit withstand without protection as per IEC 60947-3										
Rated short-time withstand current 0.3s I_{cw} at 415 VAC (kA rms)	12	12	12	15 ⁽⁴⁾	15 ⁽⁴⁾	15 ⁽⁴⁾	17 ⁽⁴⁾	17 ⁽⁴⁾		
Rated short-time withstand current 1s I_{cw} at 415 VAC (kA rms)	7	7	7	8 ⁽⁴⁾	8 ⁽⁴⁾	8 ⁽⁴⁾	11 ⁽⁴⁾	10 ⁽⁴⁾		
Rated peak withstand current at 415 VAC (kA peak)	20	20	20	30	30	30	45	45		
Connection										
Minimum Cu cable cross-section as per IEC 60947-1 (mm ²)	35	35	50	95	120	185	2 x 95	2 x 120		
Recommended Cu busbar cross-section (mm ²)							2 x 32 x 5	2 x 40 x 5		
Maximum Cu cable cross-section (mm ²)	50	95	120	150	240	240	2 x 185	2 x 300		
Maximum Cu busbar width (mm)	25	25	25	32	32	32	50	50		
Min./max. tightening torque (Nm)	9/13	9/13	9/13	20/26	20/26	20/26	40/45	40/45		
Power dissipation (W/pole)	1.9	3.2	4.1	5.9	7.8	15.1	17	32.4		
Switching time (rated voltage, after receiving command)										
Transfer time I-II or II-I (s)	0.85	0.85	0.85	0.9	0.9	0.9	0.95	0.95		
I-0 or II-0 (s)	0.55	0.55	0.55	0.5	0.5	0.5	0.55	0.55		
Contact transfer time ("black-out" I-II) minimum (s)	0.3	0.3	0.3	0.4	0.4	0.4	0.4	0.4		
Power supply										
Min./max. auxiliary power supply (VAC)	166/332	166/332	166/332	166/332	166/332	166/332	166/332	166/332		
Control supply power demand										
Inrush / nominal power (VA) - ATyS r	184/92	184/92	184/92	276/115	276/115	276/115	276/150	276/150		
Inrush / nominal power (VA) - ATyS g, p	206/114	206/114	206/114	298/137	298/137	298/137	298/172	298/172		
Mechanical specifications										
Durability (number of operating cycles)	10,000	10,000	10,000	8,000	8,000	8,000	5,000	5,000		
Weight ATyS r 3 P / 4 P (kg)	5.7/ 6.9	5.7/ 6.9	5.7/ 6.9	6.6/ 7.4	6.7/ 7.8	6.7/ 7.8	11.4/ 13.3	11.9/ 14.0		
Weight ATyS g, p 3 P / 4 P (kg)	6.8/ 8.0	6.8/ 8.0	6.8/ 8.0	7.7/ 8.5	7.8/ 8.9	7.8/ 8.9	12.5/ 14.4	13.0/ 15.1		

(1) Category with index A = frequent operation - Category with index B = infrequent operation. (3) Interphase barriers must be installed on the products.

(2) 3-pole device with 2 pole in series for the "+" an 1 pole for the "-".

(4) Values given at 690 VAC.

4-pole device with 2 poles in series by polarity.

800 to 3200 A

Thermal current I_{th} at 40°C	800 A	1000 A	1250 A	1600 A	2000 A	2500 A	3200 A	
Frame size	B6	B6	B6	B7	B8	B8	B8	
Rated insulation voltage U_i (V) (power circuit)	1000	1000	1000	1000	1000	1000	1000	
Rated impulse withstand voltage U_{imp} (kV) (power circuit)	12	12	12	12	12	12	12	
Rated insulation voltage U_i (V) (control circuit)	300	300	300	300	300	300	300	
Rated impulse withstand voltage U_{imp} (kV) (control circuit)	4	4	4	4	4	4	4	
Rated operational currents I_e (A) according to IEC 60947-6-1								
Rated voltage	Utilisation category							
415 VAC	AC-31 B	800	1000	1250	1600	2000	2500	3200
415 VAC	AC-32 B	800	1000	1250	1250	2000	2000	2000
415 VAC	AC-33 B	800	1000	1000	1000	1250	1250	1250
Rated operational currents I_e (A) according to IEC 60947-3								
Rated voltage	Utilisation category	A/B⁽¹⁾	A/B⁽¹⁾	A/B⁽¹⁾	A/B⁽¹⁾	A/B⁽¹⁾	A/B⁽¹⁾	A/B⁽¹⁾
415 VAC	AC-21 A / AC-21 B	800/800	1000/1000	1250/1250	1600/1600	-/2000	-/2500	-/3200
415 VAC	AC-22 A / AC-22 B	800/800	1000/1000	1250/1250	1600/1600	-/2000	-/2500	-/3200
415 VAC	AC-23 A / AC-23 B	800/800	1000/1000	1250/1250	1250/1250	-/1600	-/1600	-/1600
500 VAC	AC-21 A / AC-21 B	800/800	1000/1000	1250/1250	1600/1600	-/2000	-/2000	-/2000
500 VAC	AC-22 A / AC-22 B	630/630	800/800	1000/1000	1600/1600			
500 VAC	AC-23 A / AC-23 B	630/630	630/630	800/800	1000/1000			
690 VAC ⁽³⁾	AC-21 A / AC-21 B	800/800	1000/1000	1250/1250	1600/1600	-/2000	-/2000	-/2000
690 VAC ⁽³⁾	AC-22 A / AC-22 B	630/630	800/800	1000/1000	1000/1000			
690 VAC ⁽³⁾	AC-23 A / AC-23 B	630/630	630/630	800/800	800/800			
220 VDC	DC-21 A / DC-21 B	800/800	1000/1000	1250/1250	1250/1250			
220 VDC	DC-22 A / DC-22 B	800/800	1000/1000	1250/1250	1250/1250			
220 VDC	DC-23 A / DC-23 B	800/800	1000/1000	1250/1250	1250/1250			
440 VDC ⁽²⁾	DC-21 A / DC-21 B	800/800	1000/1000	1250/1250	1250/1250			
440 VDC ⁽²⁾	DC-22 A / DC-22 B	800/800	1000/1000	1250/1250	1250/1250			
440 VDC ⁽²⁾	DC-23 A / DC-23 B	800/800	1000/1000	1250/1250	1250/1250			
Current rated as conditional short-circuit with fuse gG DIN, according to IEC 60947-3								
Prospective fuse protected short-circuit withstand at 415 VAC(kA rms)	50	50	100	100				
Prospective fuse protected short-circuit withstand at 690 VAC(kA rms)	50	50	50					
Associated fuse rating (A)	800	1000	1250	2x800				
Short-circuit withstand without protection as per IEC 60947-3								
Rated short-time withstand current 0.3s I_{cw} at 415 VAC (kA rms)	64	64	64	78	78	78	78	
Rated short-time withstand current 1s I_{cw} at 415 VAC (kA rms)	35	35	35	50	50	50	50	
Rated peak withstand current at 415 VAC (kA peak)	55	55	80	110	120	120	120	
Connection								
Minimum Cu cable cross-section as per IEC 60947-1 (mm ²)	2 x 185							
Recommended Cu busbar cross-section (mm ²)	2 x 50 x 5	2 x 63 x 5	2 x 60 x 7	2 x 100 x 5	3 x 100 x 5	2 x 100 x 10	3 x 100 x 10	
Maximum Cu cable cross-section (mm ²)	4 x 185	4 x 185	4 x 185	6 x 185				
Maximum Cu busbar width (mm)	63	63	63	100	100	100	100	
Min./max. tightening torque (Nm)	9/13	9/13	20/26	40/45	40/45	40/45	40/45	
Power dissipation (W/pole)	41.7	46.9	93.3	122	178	255	330	
Switching time (rated voltage, after receiving command)								
Transfer time I-II or II-I (s)	2.8	2.8	2.8	2.9	2.8	2.8	2.8	
I-0 or II-0 (s)	1.4	1.4	1.4	1.4	1.8	1.8	1.8	
Contact transfer time ("black-out" I-II) minimum (s)	1.4	1.4	1.4	1.5	1	1	1	
Power supply								
Min./max. auxiliary power supply (VAC)	166/332	166/332	166/332	166/332	166/332	166/332	166/332	
Control supply power demand								
Inrush / nominal power (VA) - ATyS r,	460/184	460/184	460/184	460/230	812/322	812/322	812/322	
Inrush / nominal power (VA) - ATyS g, p	482/206	482/206	482/206	482/252	834/344	834/344	834/344	
Mechanical specifications								
Durability (number of operating cycles)	4,000	4,000	4,000	3,000	3,000	3,000	3,000	
Weight ATyS r 3 P / 4 P (kg)	27.9/ 32.2	28.4/ 32.9	28.9/ 33.6	33.1/ 39.4	50.7/ 61.6	50.7/ 61.6	61.0/ 75.3	
Weight ATyS g, p 3 P / 4 P (kg)	29.0/ 33.3	29.5/ 34.0	30.0/ 34.7	34.2/ 40.5	51.8/ 62.7	51.8/ 62.7	62.1/ 76.4	

(1) Category with index A = frequent operation - Category with index B = infrequent operation. (3) Interphase barriers must be installed on the products.

(2) 3-pole device with 2 pole in series for the "+" an 1 pole for the "-".

(4) Values given at 690 VAC.

4-pole device with 2 poles in series by polarity.

ATyS range

ATyS r, ATyS g, ATyS p
from 125 to 3200 A

Connections and terminals

ATyS r

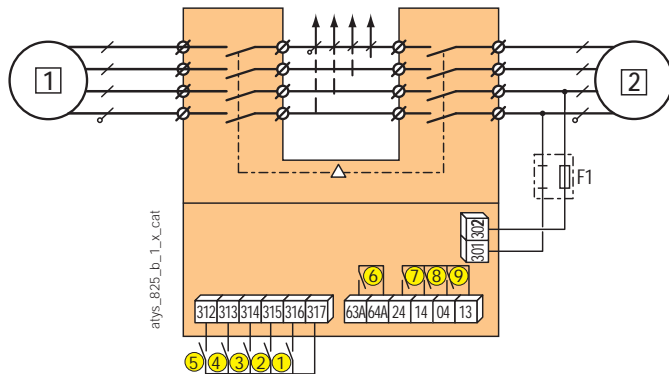

- 1 primary source (network or genset)
 - 2 backup source (mains network or genset)
- 1 : position 0 control (contact or logic if closed)
 - 2: position I control
 - 3: position II control
 - 4: primary control position 0
 - 5: closing this contact allows position control commands
 - 6: product availability relay
 - 7: auxiliary contact - closed when the switch is in position II
 - 8: auxiliary contact - closed when the switch is in position I
 - 9: auxiliary contact - closed when the switch is in position 0

ATyS r with ATyS DPS

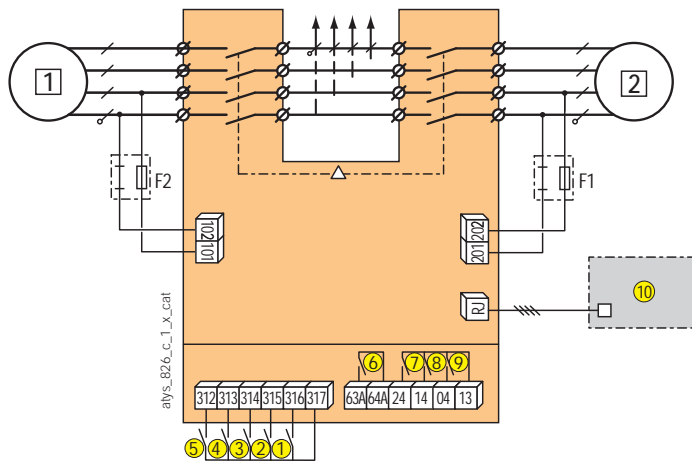

- 1 primary source (mains network or genset)
 - 2 backup source (mains network or genset)
- 1 : position 0 control (contact or logic if closed)
 - 2: position I control
 - 3: position II control
 - 4: primary control position 0
 - 5: closing this contact allows position control commands
 - 6: product availability relay
 - 7: auxiliary contact - closed when the switch is in position II
 - 8: auxiliary contact - closed when the switch is in position I
 - 9: auxiliary contact - closed when the switch is in position 0
 - 10: D10 remote interface

ATyS g

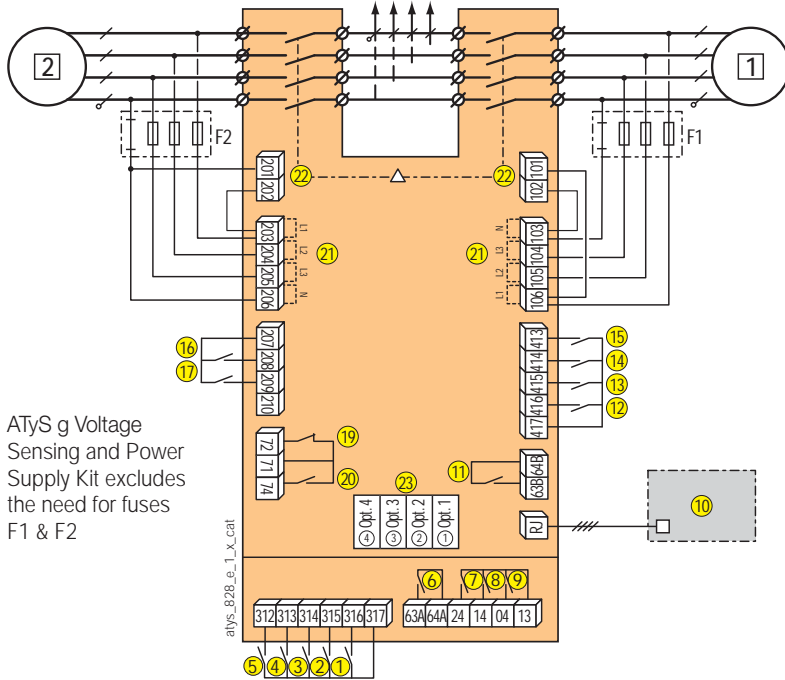

ATyS g Voltage Sensing and Power Supply Kit excludes the need for fuses F1 & F2

- 1 primary source (mains network)
- 2 backup source (genset or network)
- 1: position 0 control (contact or logic if closed)
- 2: position I control
- 3: position II control
- 4: primary control position 0
- 5: closing this contact allows position control commands
- 6: Motor unit availability relay
- 7: auxiliary contact - closed when the switch is in position II
- 8: auxiliary contact - closed when the switch is in position I
- 9: auxiliary contact - closed when the switch is in position 0
- 10: D10 remote interface
- 11: Electrical unit availability relay
- 12: automatic operation inhibited
- 13: confirm manual retransfer
- 14: bypass for time delay 2AT
- 15: M/G: priority test on load.
M/M: with or without priority.
- 16: remote test without load
- 17: M/G: test on load
M/M: preferred source selection
- 19-20: genset start and stop commands

Order	71/72 (19)	71/74 (20)
Genset start-up	Closed contact	Open contact
Genset stop	Open contact	Closed contact

- 21: voltage inputs
- 22: power inputs
- 23: 4 slots for optional RS485 communication module

ATyS p

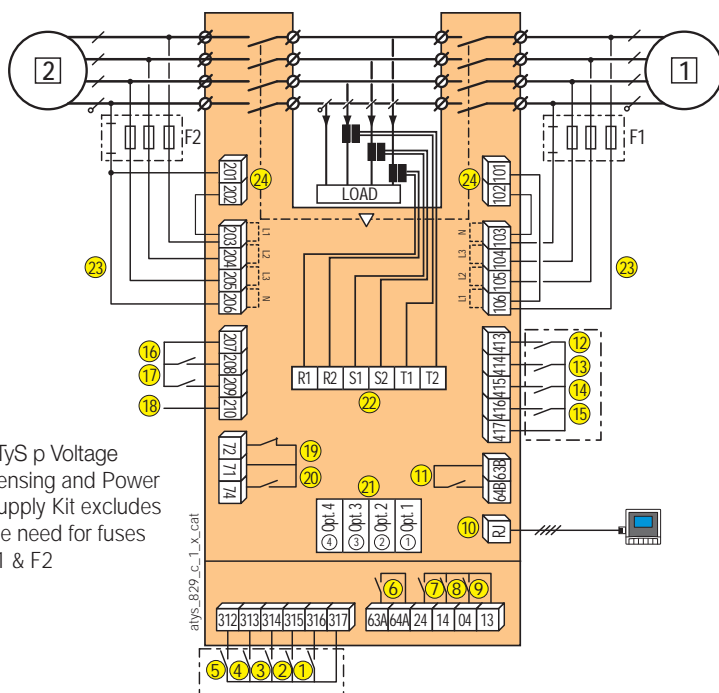

ATyS p Voltage Sensing and Power Supply Kit excludes the need for fuses F1 & F2

- 1 primary source (network or genset)
- 2 backup source (network or genset)
- 1: position 0 control (contact or logic if closed)
- 2: position I control
- 3: control position II
- 4: primary control position 0
- 5: closing this contact allows position control commands
- 6: Motor unit availability relay
- 7: auxiliary contact - closed when the switch is in position II
- 8: auxiliary contact - closed when the switch is in position I
- 9: auxiliary contact - closed when the switch is in position 0
- 10: D20 remote interface
- 11: Electrical unit availability relay
- 12-17: programmable inputs
- 18: auxiliary power supply for optional modules
- 19-20: genset start and stop commands

Order	71/72 (19)	71/74 (20)
Genset start-up	Closed contact	Open contact
Genset stop	Open contact	Closed contact

- 21: 4 slots for optional modules
- 22: T1 measurement connection
- 23: voltage inputs
- 24: power inputs

ATyS range

ATyS r, ATyS g, ATyS p
from 125 to 3200 A

Dimensions

125 to 630 A / B3 to B5

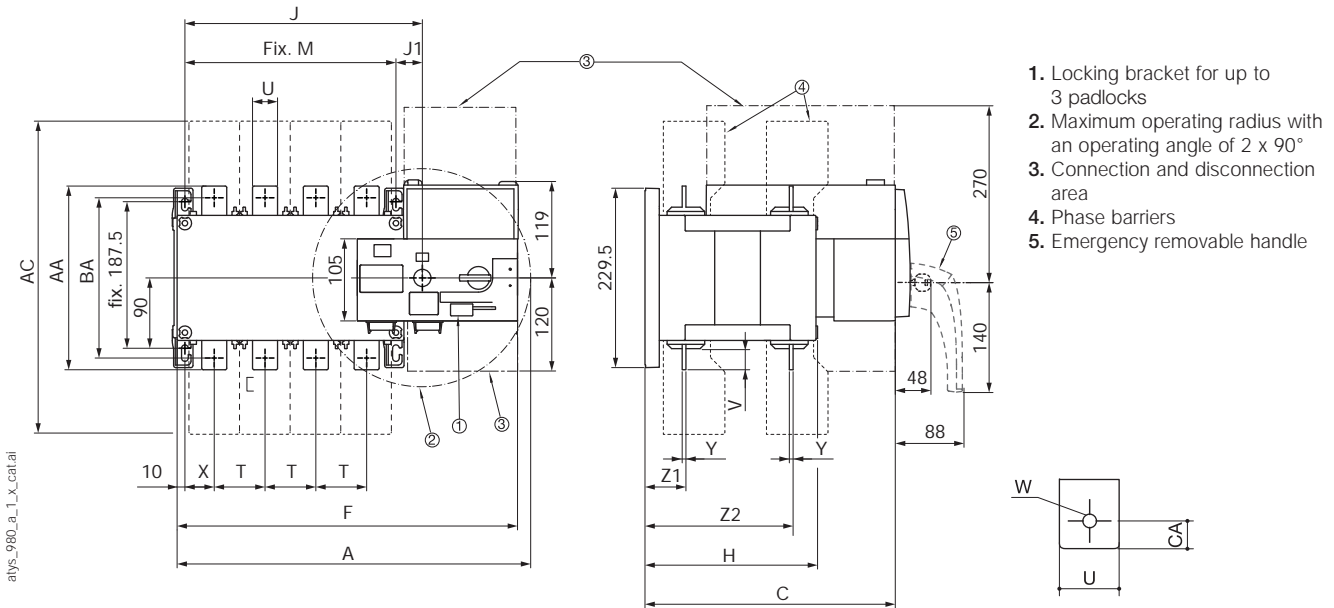

Rating (A) / Frame size	Overall dimensions			Terminal shrouds		Switch body					Switch mounting				Connection									
	A 3p.	A 4p.	C	AC	F 3p.	F 4p.	H	J 3p.	J 4p.	J1	M 3p.	M 4p.	T	U	V	W	X 3p.	X 4p.	Y	Z1	Z2	AA	BA	CA
125 / B3	304	334	244	233	286.5	317	151	154	184	34	120	250	36	20	25	9	28	22	3.5	38	134	135	115	10
160 / B3	304	334	244	233	286.5	317	151	154	184	34	120	250	36	20	25	9	28	22	3.5	38	134	135	115	10
200 / B3	304	334	244	233	286.5	317	151	154	184	34	120	250	36	20	25	9	28	22	3.5	38	134	135	115	10
250 / B4	345	395	244	288	328	378	152	195	245	35	160	210	50	25	30	11	33	33	3.5	39.5	133.5	160	130	15
315 / B4	345	395	244	288	328	378	152	195	245	35	160	210	50	35	35	11	33	33	3.5	39.5	133.5	160	130	15
400 / B4	345	395	244	288	328	378	152	195	245	35	160	210	50	35	35	11	33	33	3.5	39.5	133.5	170	140	15
500 / B5	394	454	321	402	377	437	221	244	304	34	210	270	65	32	50	14	42.5	37.5	5	53	190	260	220	20
630 / B5	394	454	321	402	377	437	221	244	304	34	210	270	65	45	50	13	42.5	37.5	5	53	190	260	220	20

800 to 1600 A / B6 to B7

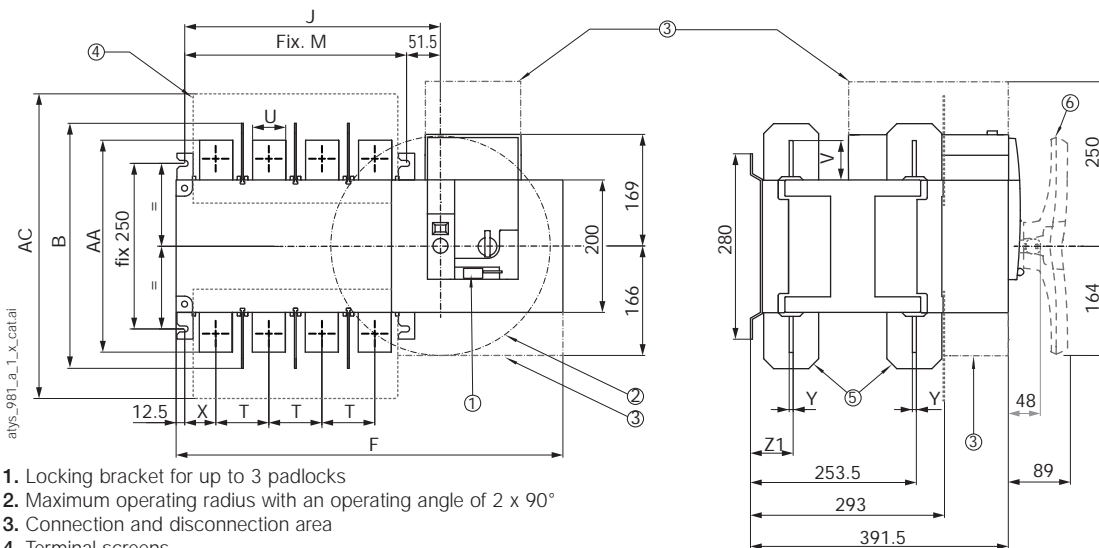

1. Locking bracket for up to 3 padlocks
2. Maximum operating radius with an operating angle of 2 x 90°
3. Connection and disconnection area
4. Terminal screens
5. Phase barriers
6. Emergency removable handle

Rating (A) / Frame size	Overall dimensions		Terminal shrouds		Switch body				Switch mounting		Connection					
	B	AC	F 3p.	F 4p.	J 3p.	J 4p.	M 3p.	M 4p.	T	U	V	X	Y	Z1	AA	
800 / B6	370	461	504	584	307	387	255	335	80	50	60.5	47.5	7	66.5	321	
1000 / B6	370	461	504	584	307	387	255	335	80	50	60.5	47.5	7	66.5	321	
1250 / B6	370	461	504	584	307	387	255	335	80	60	65	47.5	7	66.5	330	
1600 / B7	380	531	596	716	399	519	347	467	120	90	44	53	8	67.5	288	

2000 to 3200 A / B8

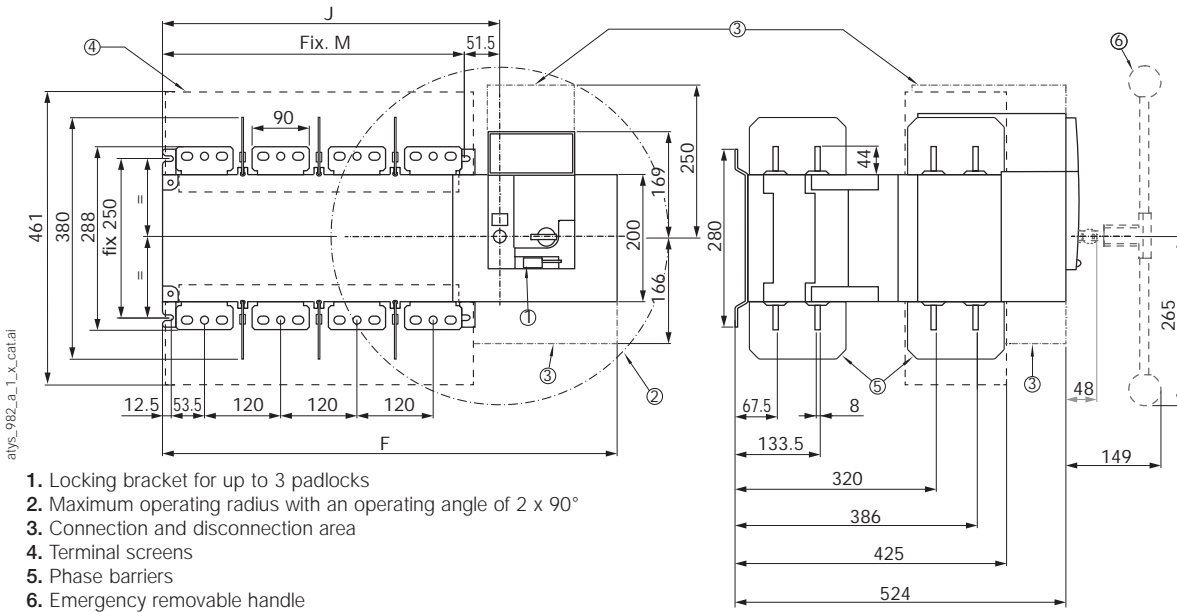

Rating (A)	Switch body				Switch mounting	
	F 3p.	F 4p.	J 3p.	J 4p.	M 3p.	M 4p.
2000 ... 3200	596	716	398.5	518.5	347	467

Door cutout

125 to 630 A / B3 to B5

ATyS r

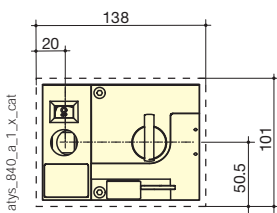

ATyS g, p

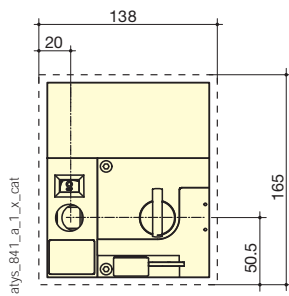

800 to 1600 A / B6 to B7

ATyS r

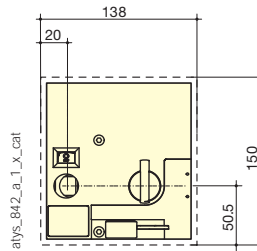

ATyS g, p

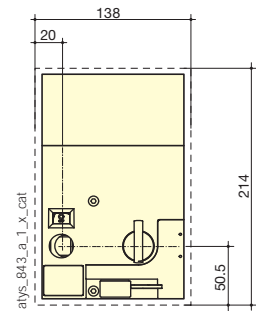

Connection terminals

800 to 1000 A / B6

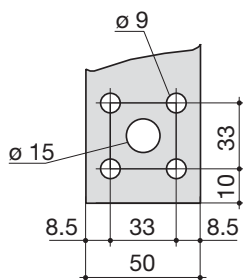

1250 A / B6

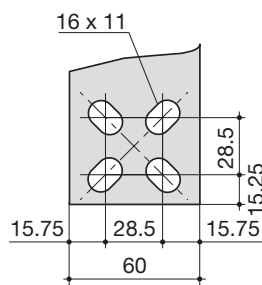

1600 to 3200 A / B7 to B8

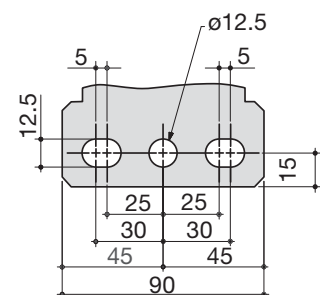

ATyS d H

Remotely operated Transfer Switching Equipment
from 4000 to 6300 A



The solution for

- > Data centre
- > Telecommunications
- > Industries



Strong points

- > Ready for installation in the enclosure of your choice
- > High-performance switching
- > Safe on-load transfer: I-0-II

Conformity to standards

- > IEC 60947-6-1



Enclosed solution

- > Please contact your SOCOMECC office

External automatic controller

- > The ATyS d H is an RTSE which is compatible with most building management systems. It may also be supplied as an ATSE by including an ATyS C55 / C65 controller with a door mounted external display.

Function

The ATyS d H is a three-phase transfer switch, 3 and 4 poles, designed for low voltage high power applications that require high-performance and fast reliable switching. The open transition transfer is performed on-load in line with IEC 60947-6-1 standards (Class PC) with minimal power supply interruption to the load during transfer.

The ATyS d H is remote transfer switching equipment (RTSE) with an integrated dual power supply (DPS) that accepts remote orders through volt-free contacts.

Advantages

Ready for installation in the enclosure of your choice

The ATyS d H has been designed to facilitate installation. It is composed of two switches that are mounted one above the other with easily accessible power connections located at the rear. Furthermore the ATyS d H does not need any external bridging bars as the load side is connected within the product. This enables to save time during installation.

Safe on-load transfer: I-0-II

The ATyS d H includes two mechanically interlocked switches to ensure fast switching whilst providing a neutral (Off - 0) position. This ensures that the main and alternative power supplies do not overlap.

High-performance switching

The ATyS d H offers high withstand short circuit current ratings of 143 kA I_{cm} (making) and 65 kA for 0.1sec I_{cw} (withstand). Further to its high short circuit withstand, the ATyS d H performance in terms of load switching capacity is AC-33iB ($6 \times I_n \cos \phi 0.5$) without derating.

References

Rating (A)	Number of poles	ATyS d H Reference	Control relay Reference
4000 A	3P	9533 3400	ATyS C55 1600 0055
	4P	9533 4400	
5000 A	3P	9533 3500	
	4P	9533 4500	
6300 A	3P	9533 3630	ATyS C65 1600 0065
	4P	9533 4630	

Characteristics according to IEC 60947-6-1

Thermal current I_{th} at 40°C	4000 A	5000 A	6300 A
Rated operating voltage U_e (V)	660		
Rated insulation voltage U_i (V)	660		
Rated impulse withstand voltage U_{imp} (kV)	12		
Rated short-circuit withstand at 660 VAC			
Rated short-time withstand current 0.1s I_{cw} (kA rms)	65		
Rated peak withstand current (kA peak)	143		
Rated operational current I_e (A), at 660 VAC - AC32B	4000	5000	6300
Rated operational current I_e (A), at 660 VAC - AC33iB (6xIn cos Ø 0.5)	4000	5000	6300
Connection			
Rear connection with busbar	•	•	•
Power dissipation (W/pole)	128	200	317
Switching time			
I to 0 (ms)	≤ 150		
0 to I and 0 to II (ms)	≤ 90		
II to 0 (ms)	≤ 200		
I-0-II / II-0-I (s)	1.2		
Operating frequency	10 operations per hour		
Power supply			
VAC power supply (powered directly on terminals S1 and S2)	230		
Main coil operating current (peak during transfers)	65 A ⁽¹⁾		
Mechanical characteristics			
Durability (number of operating cycles)	3000		
Weight (kg) - Fixed 3/4P model	200 / 250	200 / 250	200 / 250

(1) Instantaneous value. For a complete operation, power should be available during 0.5 s.

Dimensions

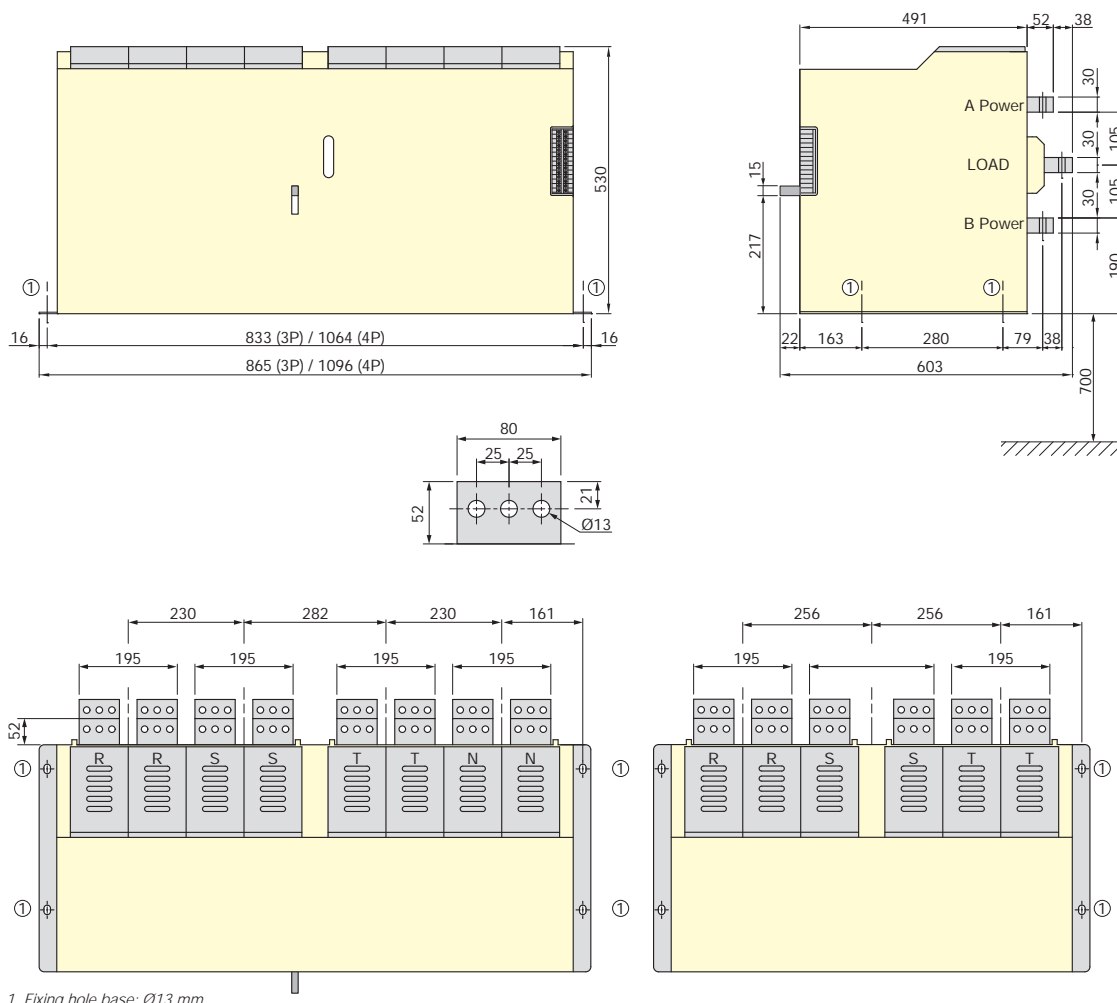

1. Fixing hole base: Ø13 mm

ATyS C25

ATS Controller
simple functions



atysc_015.eps

ATyS C25

Function

ATyS C25 is an entry level ATSE controller with communications. It can be used to pilot a remotely operated transfer switch, such as ATyS r, ATyS S and ATyS d M, as well as contactors type transfer switches, for circuit breaker type transfer switches see ATyS C55 and ATyS C65. ATyS C25 ensure the automatic or remotely controlled transfer from one source to another with fixed timers and thresholds.

Advantages

Flexible space saving

The ATyS C25 controller can be mounted on either a DIN rail or to the panel door, offering flexibility and optimising space.

Cost-effective

The ATyS C25 has an integrated DPS, for supplying the motorisation of the switch, and can be door mounted, therefore there's no need for an external DPS or display, reducing installation time and costs.

Fast commissioning & testing

- 8 dip-switches allow very fast commissioning, even offline.
- All main functions such as remote position control, mode selection, lamp test and genset test on load are available on the front of the product allowing quick and easy operation.
- Remote product information is available through RS485 Modbus communication.

General characteristics

- Self-powered from sensing.
- Voltage supply range (184 - 300 VAC).
- DC aux power supply (for optional use).
- Main/Main or Main/Genset networks.
- Fixed I/Os.
- RS485 Modbus communication.
- Voltage sensing on all phases.
- Three-phase + Neutral & Single-phase + Neutral networks.
- Phase rotation checking.
- Door or DIN rail mounting.

The solution for

- > ATS panels
- > Compact transfer enclosures
- > Basic ATS controls



Strong points

- > Self-supplied from sensing circuit
- > Integrated AC Double Power Supply
- > RS485 Communications
- > Multiple mounting options

Conformity to standards

- > IEC 61010-2-201
- > IEC 60947-6-1
- > GB/T 14048.11 Annex C



Compatible with



ATyS r
Transfer Switching Equipment

References

Description	Reference
ATyS C25 – ATS controller	1600 0025
ATyS r - Remotely operated Transfer Switching Equipment	9523 xxxx ⁽¹⁾

(1) xxxx variable based on the number of poles and rating.

Front panel

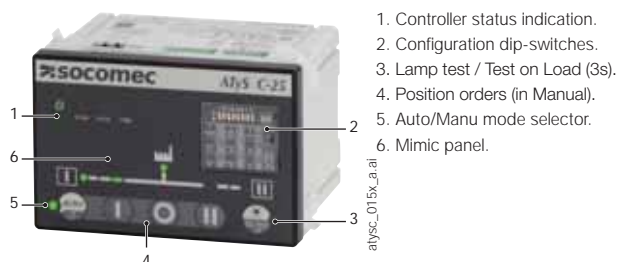

Dimensions (mm)

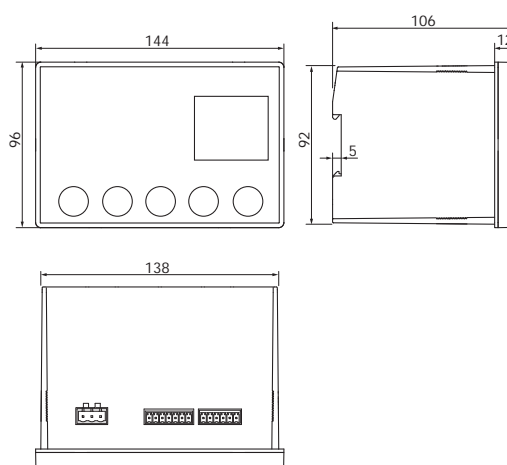

atySc_001_Lb_1_x_catal

Characteristics

Electrical characteristics	
AC operating limits	184 ⁽¹⁾ - 300 VAC
Optional DC supply	10-30 VDC
Frequency limits	45 - 65 Hz
Power consumption	< 10 W
Inputs	5 - fixed (auto inhibit & DC fire input, position indication I-0-II)
Outputs	4 - fixed (position control I-0-II & genset start)
Impulse withstand	6/4 kV ⁽²⁾
Overvoltage category	CAT 3
Mechanical characteristics	
Weight	845 gr
Door cutout	138 x 92 mm
Operating temperature	-25 ... +70°C
Communications	
Interface type	RS485. 2 to 3 half duplex wires
Protocol	MODBUS RTU
Baudrate	2400-38400

Measurement characteristics	
Nominal voltage DIP 1 (1PH+N / 3P+N)	230 / 400 VAC
Nominal frequency (fixed)	50 Hz
Voltage threshold settings DIP 4	10% / 20% of Nominal voltage
Frequency threshold settings DIP 4	5% / 10% of nominal frequency
Voltage and frequency Hysteresis (fixed)	20% of ΔU/ΔF
Other settings	
ODT dead-band timer DIP 5	0 / 2 s
FT Source 1 and 2 fail timer DIP 6	3 / 10s
RT Source 1 and 2 return timer DIP 7&8	0 (3s) / 3 / 10 / 30 min
Source priority DIP 2	Priority source 1 / No priority
Position Output signal DIP 3	Impulse / Maintained

(1) 200 VAC in contactor mode.

(2) 6 kV tested between phases of a different source and 4 kV tested between phases of a the same source.

Terminals

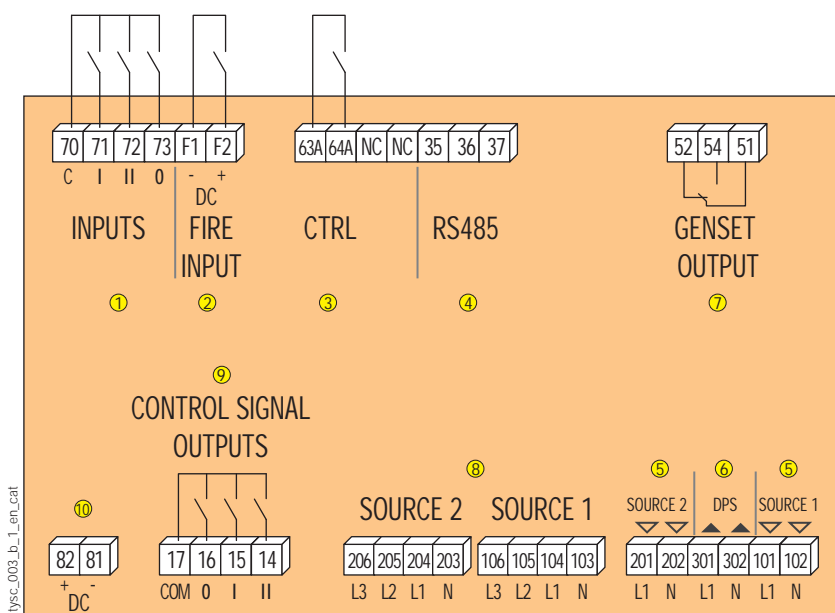

1. Switch position inputs
2. DC fire input (forces 0 & inhibit)
3. Control inputs
4. RS485 communication
5. DPS input (source 1 and 2)
6. DPS output to motor
7. Genset NO/NC output
8. Voltage sensing S1 & S2
9. Control outputs to transfer device
10. DC aux power supply (for optional use)

atySc_003_b_1_en_cat

ATyS C35

ATS Controller
digital functions

new



ATyS C35

The solution for

- > ATS panels
- > Compact transfer enclosures
- > Simple ATS controls



Strong points

- > Self-supplied from sensing circuit
- > Integrated AC Double Power Supply
- > RS485 Communications
- > Multiple mounting options
- > LCD Display

Conformity to standards

- > IEC 61010-2-201
- > IEC 60947-6-1
- > GB/T 14048.11 Annex C



Compatible with



ATyS r
Transfer Switching Equipment

Function

ATyS C35 is an ATS controller with a display screen and communication functionality. It is specifically designed to pilot Socomec remotely operated transfer switches, such as ATyS r, ATyS S and ATyS dM, and can also function with other brands using switch based, contactor based or circuit breaker based remote transfer switches.

ATyS C35 ensures the automatic or remote transfer in open transition from one source to another with programmable thresholds and timers. This controller also displays the information that it collects from the network and switch both on screen as well as on the LED synoptic, enabling users to keep track of the installation status.

Advantages

Flexible space saving

The AtyS C35 controller can be mounted on either a DIN rail or to the panel door, offering flexibility and optimising space.

Cost-effective

The AtyS C35 has an integrated DPS, for supplying the motorisation of the switch, and can be door mounted, therefore there's no need for an external DPS or display, reducing installation time and costs.

Flexible configuration options

- Programmable thresholds and timers.
- 3 programmable inputs.
- Functional with PC, CB or CC.

Display and communications

- Displays voltages, frequencies and phase angle.
- Timer counters displayed on screen.
- RS485 Modbus communications for monitoring and programming.

General characteristics

- Self-powered from sensing.
- Voltage supply range (184 - 300 VAC).
- DC aux power supply (for optional use).
- Main/Main or Main/Genset networks.
- Programmable inputs.
- RS485 Modbus communication.
- Voltage sensing on all phases.
- Three-phase + Neutral & Single-phase + Neutral networks.
- Phase rotation checking.
- Door or DIN rail mounting.

References

Description	Reference
ATyS C35 – ATS controller	1600 0035
ATyS r - Remotely operated Transfer Switching Equipment	9523 xxxx ⁽¹⁾

(1) xxxx variable based on the number of poles and rating.

Front panel



1. Controller status indication.
2. Configuration dip-switches.
3. Dashboards / Test on Load (3s).
4. Position orders (in Manual).
5. Auto/Manu mode selector.
6. Mimic panel.

atysc_0xxx_8.ai

Dimensions (mm)

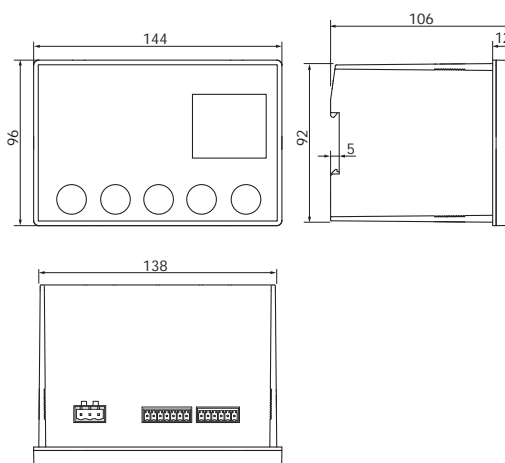

atysc_001_lb_1_x_catal

Characteristics

Electrical characteristics	
AC operating limits	184 ⁽¹⁾ - 300 VAC
Optional DC supply	10-30 VDC
Frequency limits	45 - 65 Hz
Power consumption	< 10 W
Inputs	4 fixed 3 programmable
Outputs	4 fixed - 1 programmable ⁽³⁾
External DPS max current (240 VAC)	6A AC1 - 1.5A AC15
Impulse withstand	6/4 kV ⁽²⁾
Overvoltage category	CAT 3

Mechanical characteristics

Weight	845 gr
Door cutout	138 x 92 mm
Operating temperature	-25 ... +70°C
Communications	
Interface type	RS485. 2 to 3 half duplex wires
Protocol	MODBUS RTU
Baud rate	2400-38400

(1) 200 VAC in contactor mode.

(2) 6 kV tested between phases of a different source and 4 kV tested between phases of a the same source.

(3) Only in main-main mode.

Terminals

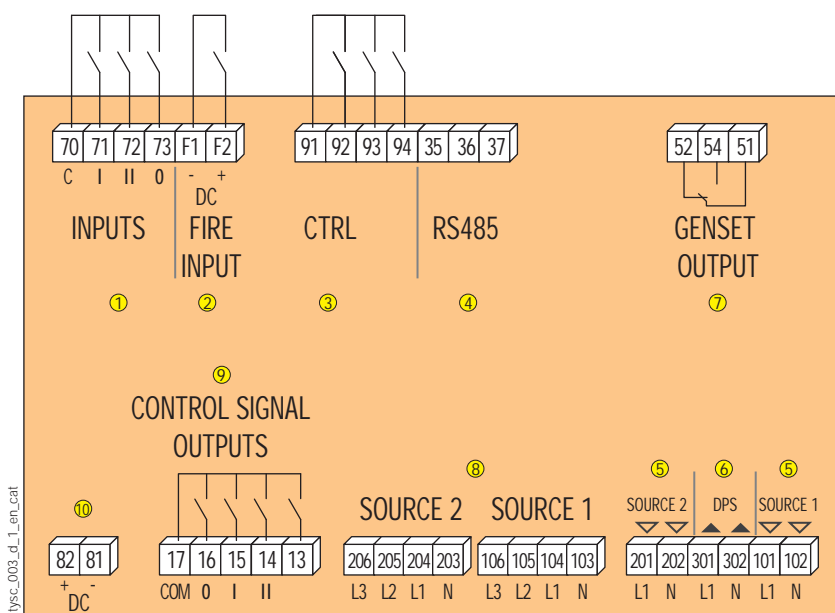

atysc_003_d_1_en_cat

1. Switch position inputs
2. DC fire input (forces 0 & inhibit)
3. Control inputs
4. RS485 communication
5. DPS input (source 1 and 2)
6. DPS output to motor
7. Genset NO/NC output
8. Voltage sensing S1 & S2
9. Control outputs to transfer device
10. DC aux power supply (for optional use)

ATyS C55

ATS Controller
smart functions



ATyS C55

Function

ATyS C55 is a complete ATSE controller that can be used to pilot a remotely operated transfer switch of any technology: motorised switches (e.g. ATyS r, ATyS S or ATyS d M), circuit breakers or contactors. ATyS C55 ensure the automatic or remotely controlled transfer from one source to another, with configurable timers and thresholds, for any combination of sources: 2 transformers, 1 transformer and 1 genset or 2 gensets.

Advantages

Fast commissioning

On initial power up, the ATyS C55's smart wizard will guide the operator through the commissioning process.

Versatile

The ATyS C55 is compatible with contactors, breakers and switches. It can also work for all type of 2-source applications combining mains and gensets.

Clear visualisation and operation

- High-resolution LCD screen with clear defined messages.
- Real-time pop-ups to show timers, alarms, faults and information alerts.
- Quick and easy access to main functions through the front face with direct key input.
- Complete configuration can be achieved through the front face or via software (EasyConfig).

General characteristics

- Self-powered from sensing.
- Wide voltage range (88-576VAC).
- 24 VDC aux power supply (for optional use).
- 2 latching relays.
- Smart commissioning wizard.
- IP65 degree of protection with gasket (accessory).
- 1000 Alarms and Events.
- 6 fully configurable I/O.
- Genset scheduler.
- Door or back plate mounting.
- Main/Main, Main/Genset and Genset/Genset applications.
- Easyconfig configuration software.
- RS485 Modbus communication.
- Ethernet, SNMP, BACnet using DIRIS M-70 gateways. Includes Webserver.
- A DIRIS Digiware D-70 gateway can be utilised as a remote display for multiple ATyS C55/C65 controllers; the D-70 also provides Ethernet, SNMP & BACnet connectivity.

The solution for

- > Commercial buildings
- > Applications:
 - Genset/Genset
 - Network/Genset
 - Network/Network
 - External/portable systems



Strong points

- > Smart commissioning
- > Intuitive use
- > Hi-resolution LCD screen

Conformity to standards

- > IEC 61010-2-201
- > IEC 60947-6-1
- > GB/T 14048.11 Annex C



Communication gateways



DIRIS Digiware M-70 & D-70

Compatible with



ATyS r
Transfer Switching
Equipment

Double power supply
DPS Optional for use
with ATyS r, breakers
and contactors without
integrated DPS

References

Description	Reference
ATyS C55 – ATS controller (includes mounting kits)	1600 0055
IP65 gasket for door cut-out (1)	1609 0001
DIRIS Digiware M-50 multi-protocol Ethernet gateway	4829 0221
DIRIS Digiware D-50 multipoint display, Ethernet output	4829 0204
DIRIS Digiware M-70 communication gateway for Ethernet & Webserver	4829 0222
DIRIS Digiware D-70 communication gateway for Ethernet & Webserver and multi-product display	4829 0203
Double power supply - DPS	1599 4001
ATyS r - Remotely operated Transfer Switching Equipment	9523 xxxx (2)

(1) The gasket provides an IP65 seal between the controller and the panel door; the front face (display & keys) is IP65 as standard.

(2) xxxx variable based on the number of poles and rating.

Front panel

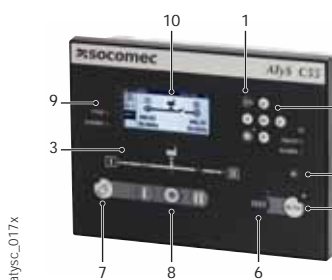

atyssc_017x

1. Dashboard displays.
2. Navigation keypad.
3. Mimic LED indication.
4. Lamp test button / LED info.
5. AUTO mode select.
6. TEST button.
7. CONTROL mode select.
8. Position orders (only in CONTROL mode).
9. Inhibit and communication indication.
10. Hi-res LCD screen.

Dimensions (mm)

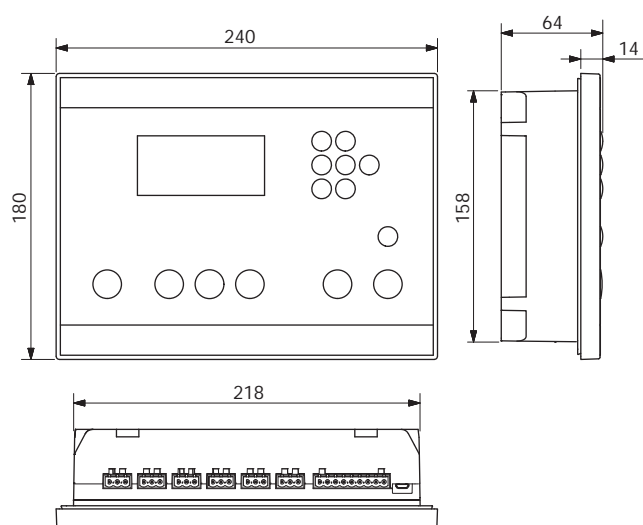

atyssc_006_a_1_x_cat.ai

Characteristics

Electrical characteristics

AC operating limits	110 - 480 VAC ±20%
Optional DC supply	24 VDC
Frequency limits	45 - 65 Hz
Power consumption	< 10 W
Inputs	6, fully programmable
Outputs	6, fully programmable
Output relays	8 A AC15
EMC classification	Class A and B
Impulse withstand	8/6 kV ⁽¹⁾
Overvoltage category	CAT 3

(1) 8 kV tested between phases of a different source and 6 kV tested between phases of a the same source.

Mechanical characteristics

Weight	1080 gr
Door cutout	220 x 160 mm
Protection degree	IP65 with optional gasket
Operating temperature	-30 ... +70 °C

Communications

Interface type	RS485. 2 to 3 half duplex wires
Protocol	MODBUS RTU
Baudrate	programmable 1200 - 115200 bps

Display

Screen resolution	350 x 160 pixels
Event recorder	1000 events

Terminals

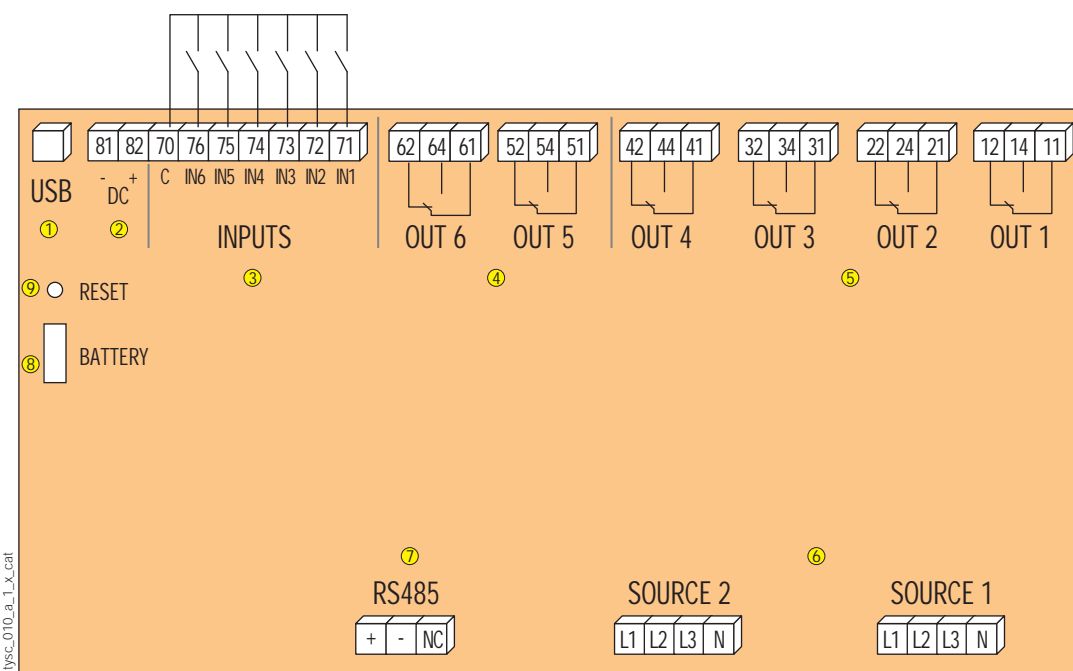

atyssc_010_a_1_x_cat

1. Configuration USB
2. 24 VDC aux power supply (for optional use)
3. 6 x inputs
4. 2 x latching relay outputs
5. 4 x relay outputs
6. Source sensing (110-480 ±20%)
7. RS485 communication
8. Replaceable RTC battery
9. Hard reset button

ATyS C65

ATS Controller

connected functions



ATyS C65

Function

ATyS C65 is an advanced ATSE controller offering all the functions of the ATyS C55 with the addition of current, power & energy monitoring, increased I/O capacity and functions, load shedding, lift control function, energy backup, increased number of events and alarms (measurement and combination alarms) and DIRIS Digiware module compatibility.

Advantages

Fast commissioning

On initial power up, the ATyS C65's smart wizard will guide the operator through the commissioning process.

User customisable

Front face LEDs, Load shedding, Genset schedulers and the lift control signal are just a few of the many customisable features available on ATyS C65.

Intuitive operation

- The high-resolution LCD screen provides several dashboards enabling easy monitoring of all parameters, including power and energy consumption of the loads.
- The integrated energy backup provides transitional power to the product enabling status indication (switch position, timer status, fault notifications) and communication to remain active with no supply present.
- Quick and easy access to main functions through the front face with direct key input.
- Complete configuration can be achieved through the front face or via software (EasyConfig).

General characteristics

- Self-powered from sensing.
- Wide voltage range (88 - 576 VAC).
- 24 VDC aux power supply (for optional use).
- 2 latching relays.
- Digiware IO-10: I/O extension up to 30 inputs and 18 outputs.
- Power & Energy metering with /1 A or /5 A current transformers.
- Energy backup.
- IP65 degree of protection (panel gasket included).
- 3000 Alarms and Events.
- Multiple fully configurable timers, thresholds and I/O.
- Easyconfig configuration software.
- Shock resistant IK08+.
- Digiware compatible (replaces U module).
- Ethernet, SNMP, BACnet using DIRIS M-70 gateway. Includes Webserver.
- A DIRIS Digiware D-70 gateway can be used as a remote display for multiple ATyS C55/C65 controllers; the D-70 also provides Ethernet, SNMP & BACnet connectivity.

The solution for

- > Life safety
- > Critical applications
- > Transfer panels with ACB



Strong points

- > Advanced I/O functions
- > Power monitoring
- > Energy backup

Conformity to standards

- > IEC 61010-2-201
- > IEC 60947-6-1
- > GB/T 14048.11 Annex C



Communication gateways



DIRIS Digiware M-70 & D-70

Compatible with

ATyS r
Transfer Switching
EquipmentDouble power supply
DPS Optional for use
with ATyS r, breakers
and contactors without
integrated DPS

References

Description	Reference
ATyS C65 – ATS controller (includes mounting kits) and IP65 gasket	1600 0065
DIRIS Digiware M-50 multi-protocol Ethernet gateway	4829 0221
DIRIS Digiware D-50 multipoint display, Ethernet output	4829 0204
DIRIS Digiware M-70 communication gateway for Ethernet & Webserver	4829 0222
DIRIS Digiware D-70 communication gateway for Ethernet & Webserver and multi-product display	4829 0203
Double power supply - DPS	1599 4001
ATyS r - Remotely operated Transfer Switching Equipment	9523 xxxx ⁽¹⁾

(1) xxxx variable based on the number of poles and rating.

Front panel



1. Dashboard displays.
2. Navigation keypad.
3. Mimic LED indication.
4. Lamp test button / LED info.
5. AUTO mode select.
6. TEST button.
7. CONTROL mode select.
8. Position orders (only in CONTROL mode).
9. Customisable LED.
10. Hi-res LCD screen.

Dimensions (mm)

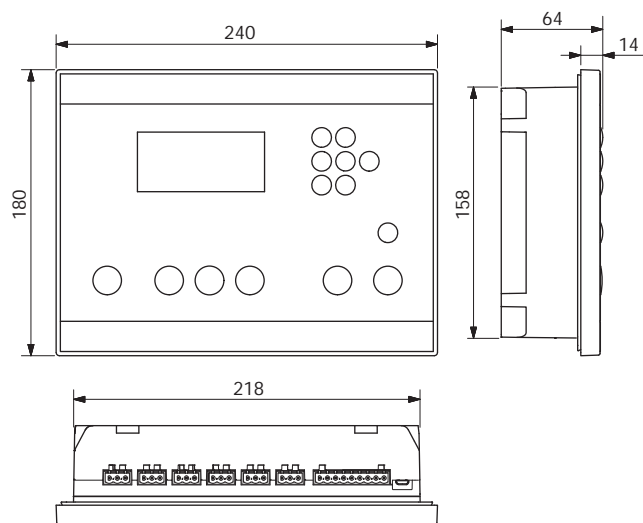

Characteristics

Electrical characteristics	
AC operating limits	110 - 480 VAC ±20%
Optional DC supply	24 VDC
Frequency limits	45 - 65 Hz
Power consumption	< 10 W
Current transformers	1 or 5A
Measurement type	true RMS (TRMS)
Inputs	6, fully programmable
Outputs	6, fully programmable
Output relays	8 A AC15
I/O Extension (IO10)	up to 30 inputs and 18 outputs
EMC classification	class A and B
Impulse withstand	8/6 kV ⁽¹⁾
Overtoltage category	CAT 3

Mechanical characteristics	
Weight	1080 gr
Door cutout	220 x 160 mm
Protection degree	IP65
Operating temperature	-30 ... +70 °C
Communications	
Interface type	RS485. 2 to 3 half duplex wires
Protocol	MODBUS RTU
Baudrate	programmable 1200 - 115200 bps
Digiware bus	RJ45 cable
Display	
Screen resolution	350 x 160 pixels
Event recorder	3000 events
Energy backup	up to 30 seconds

(1) 8 kV tested between phases of a different source and 6 kV tested between phases of a the same source.

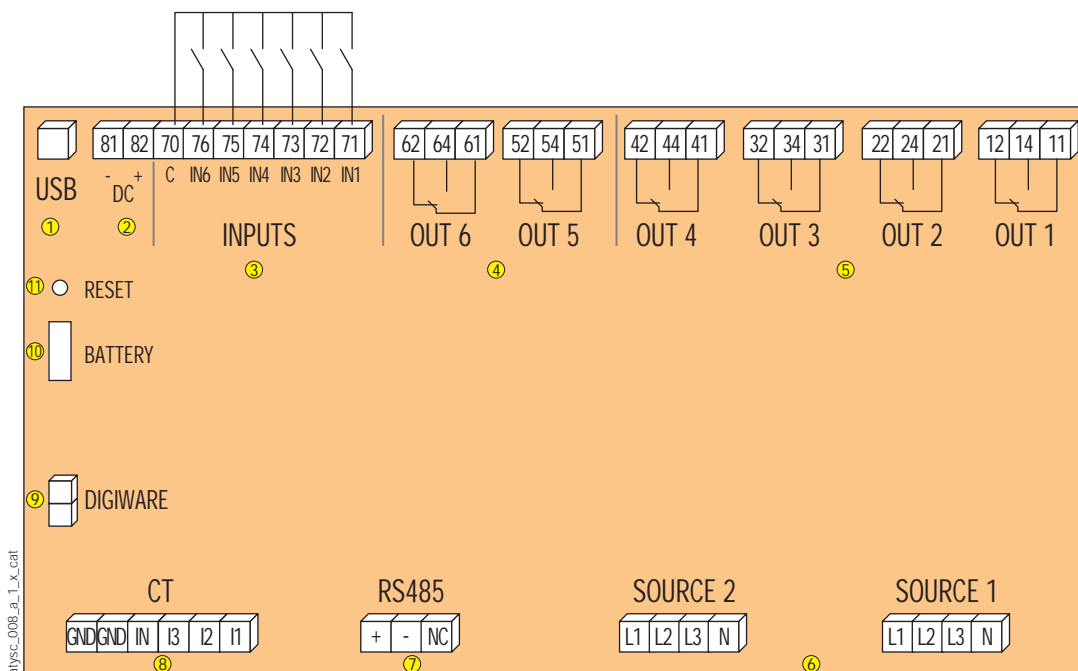

Terminals



1. Configuration USB
2. 24 VDC aux power supply (for optional use)
3. 6 x inputs
4. 2 x latching relay outputs
5. 4 x relay outputs
6. Source sensing (110 - 480 ±20%)
7. RS485 communication
8. Current transformers (1 or 5 A)
9. Digiware RJ45 connectors
10. Replaceable RTC battery
11. Hard reset button

The UL product range

A range of manual or remotely operated transfer switches up to 1200 A

MTSE (Manual)	RTSE (Remotely operated)
 <p data-bbox="248 1104 526 1137">SIRCOVER UL1008</p> <p data-bbox="197 1140 577 1167">Manual Transfer Switching Equipment</p>	 <p data-bbox="695 1104 890 1137">ATyS UL1008</p> <p data-bbox="593 1140 999 1167">Motorised Transfer Switching Equipment</p>

Typical applications

The ATyS UL 1008 range provides safe transfer for mains/genset and genset/genset applications.

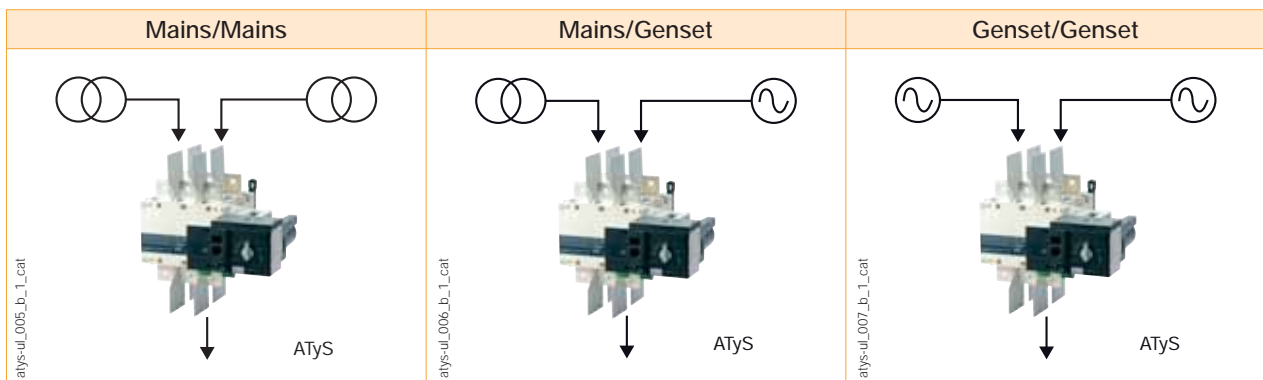

Function

ATYS and SIRCOVER UL 1008 transfer switching equipment ensure:

- Maintenance free transfer switching equipment with a robust and reliable design.
- Power control and safety between a normal and an alternate source.
- Integrated and robust switch disconnection.
- A stable OFF position with integrated padlocking to facilitate safe downstream maintenance.
- Positive break indication with clear visible position indication I - 0 - II.
- An inherent failsafe mechanical interlock prevents asynchronous paralleling of the two sources.
- Stable positions (I – 0 – II) non-affected by typical vibration and shock.
- Constant pressure on the contacts non affected by network voltage perturbation.
- Quick, easy and extremely safe manual operation.

Further to the above the ATyS also includes:

- A simple and secure motorisation remote controls interface.
- Integrated switch position auxiliary contacts.
- An active "product availability" status feedback.
- Compatibility with virtually any make of ATS, AMF and Genset controller provided with volt-free contacts.

Power supply continuity for most electrically controlled total system optional standby power applications.

SOCOMECL UL products

The ATYS UL is a full load break transfer switch where the main switching components are from proven technology devices (SIRCOVER - Manual Transfer Switches) also fulfilling requirements in UL 98 and IEC 60947-3 standards. The transfer is done in open transition with a minimum supply interruption during transfer ensuring full compliance with UL 1008 and IEC 60947-6-1 international TSE standards.

As a stand-alone product, the ATyS is a non-automatic power transfer switch (an electrically operated transfer switch that is not self-acting), generally used in applications where the load is non-emergency, does not require automatic transfer and where operating persons can be made available to initiate the transfer.

The electrical control of the ATyS UL may be direct through push-buttons and dry contacts fitted onto the enclosure door or through a dedicated local or remote ATS controller.

Your preferred brand of ATS controller, genset / AMF controller or power / building management system, may easily be paired with the ATyS to provide a complete automatic transfer switch to suit your needs.

ATyS have three stable positions (I-0-II) which can be selected remotely, via volt-free contacts, or directly, through use of the emergency operation handle; emergency operation requires no supply to be present. The OFF position provides disconnection of both supplies ensuring downstream isolation for safe maintenance.

UL Applications

ATYS UL 1008 transfer switches are rated from 100 to 1200 A and designed for use in total system optional standby power applications for the safe transfer of a load supply between a normal and an alternate source.

Optional standby systems are those systems installed to provide an alternate source of power for structures for which a power outage could cause discomfort or interruption or damage to products or processes.



Energy measurement & management

Integrated technologies	p. 294
Measurement and monitoring system for electrical installations AC selection guide	p. 296
Active energy meters and pulse concentrators selection guide	p. 342
Multifunction meters selection guide	p. 362
Current transformers selection guide	p. 406
Software solutions selection guide	p. 422

Multi-circuit metering & measurement

DIRIS Digiware AC



DIRIS Digiware D
p. 302



DIRIS Digiware C
p. 308



DIRIS Digiware M
p. 312



DIRIS Digiware U
p. 318



DIRIS Digiware S
p. 320



DIRIS Digiware I
p. 324

DIRIS Digiware DC



DIRIS Digiware R-60
p. 336



DIRIS Digiware IO
p. 340

Single-circuit metering, measurement & analysis



COUNTIS E
p. 344



MULTIS L50
p. 358



DIRIS A
p. 364



DIRIS B
p. 386

Software suite

Embedded web server
WEBVIEW



p. 424

Configuration software
Easy Config System



p. 426

Current sensors



AC current sensors
TE, TR, iTR, TF
p. 328

Quality analyser



DIRIS Q800
p. 402

Measurement devices



Current transformers
5 to 6000 A
p. 408

Integrated technologies

Groundbreaking technologies for greater simplicity and performance



PreciSense

Products that are setting new standards in measurement accuracy

The PreciSense technology ensures 100% reliable accuracy across the global measurement chain.

Be guaranteed of the accuracy of your measurements:

- for the global measurement chain,
- for reliable measurements,
- for relevant corrective actions.

PreciSense offers the best accuracy on the market regardless of the type of current sensors used (solid core, split core, flexible or embedded in the DIRIS Digiware S module).



Discover the video

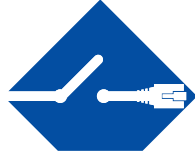

VirtualMonitor

The simple and cost-saving solution for monitoring your protective devices

The VirtualMonitor technology enables an advanced monitoring of protective devices at all levels within the electrical installation.

Virtual Monitor:

- detects the position and status of the protective device,
- detects if the breaker has tripped,
- counts the number of operations and trips.

VirtualMonitor technology monitors the status of protective devices:

- On your entire electrical installation (without additional space).
- Remotely and in real-time.
- Without additional hardware or wiring (without adding auxiliary contacts).



Discover the video



AutoCorrect

Software elimination of wiring errors

The AutoCorrect technology ensures that the measurement is properly wired at all times, thus avoiding on-site interventions.

AutoCorrect ensures the operation of the proper measuring system thanks to simple and rapid detection of wiring errors:

- automatic wiring control (voltage/current phase association),
- correction of errors with a single click,
- feature available off-load.

Error correction's are carried out without any physical modification to the wiring.



Discover the video



SYDIV_419_A

PreciSense, VirtualMonitor and AutoCorrect technologies are embedded in Socomec's power monitoring solutions.

Power metering and monitoring system for AC electrical installations

- DIRIS Digiware S with its 3 integrated sensors and DIRIS Digiware I associated with iTR sensors.



Multifunction meters

- DIRIS A-40 with iTR sensors.



Selection guide

Power monitoring system AC

DIRIS Digiware AC

Build your own AC system

System interface, displays and gateways
(24 VDC)

Bluetooth

Bluetooth

or

or

+

DIRIS Digiware D
display

DIRIS Digiware M
gateway

DIRIS Digiware C
RS485 interface

Voltage acquisition module

DIRIS Digiware U

Current acquisition module with integrated sensors

DIRIS Digiware S

Current acquisition modules

+

DIRIS Digiware I-3x
3 inputs

DIRIS Digiware I-4x
4 inputs

DIRIS Digiware I-6x
6 inputs

Current sensors

+

TE
Solid

TR/iTR
Split-core

TF
Flexible

Digital and analogue input/output modules

+

DIRIS Digiware IO





Find the best DIRIS Digiware configuration!





The Socomec Meter Selector is your digital assistant, helping you find the best DIRIS Digiware configuration for your power monitoring projects, and all in just a few clicks!

- Fill in information regarding your project.
- Download the system diagram and bill of material.
- All your projects are archived in your personal account.

Control and power supply interface

Application	Centralisation and display of data				Data centralisation	Repeater
						
DIRIS Digiware	D-50 <i>p. 302</i>	D-70 <i>p. 302</i>	M-50 <i>p. 312</i>	M-70 <i>p. 312</i>	C-31 <i>p. 308</i>	C-32 <i>p. 308</i>
Function						
Centralising measurement points	•	•	•	•	•	
High-resolution LCD display (configuration, selection and visualisation display of circuits)	•	•				
Repeater						•
Power supply						
24 VDC	•	•	•	•	•	•
Communication						
RS485 Modbus	Input/Output	Input/Output	Input/Output	Input/Output	Output	
Digiware bus	•	•	•	•	•	•
Bluetooth	•	•	•	•		
Ethernet	Modbus TCP BACnet IP SNMP	Modbus TCP BACnet IP SNMP	Modbus TCP BACnet IP SNMP	Modbus TCP BACnet IP SNMP		
Embedded web server	WEB-CONFIG	WEBVIEW-M	WEB-CONFIG	WEBVIEW-M		

Voltage acquisition module

Application	Metering	Analysis
		
DIRIS Digiware U	U-10 <i>p. 318</i>	U-30 <i>p. 318</i>
Multi-measurement		
U12, U23, U31, V1, V2, V3, f	•	•
U system, V system		•
Ph/N unbalance		•
Ph/Ph unbalance		•
Quality analysis		
THDv1, THDv2, THDv3, THDu12, THDu23, THDu31		•
Crest factors V1, V2, V3, U12, U23, U31		•
Individual harmonics U & V (up to 63rd)		•
Voltage dips, interruptions and swells (EN50160)		•
Alarms		
On threshold		•
History		
Average values		•
Format		
Width/number of modules	18 mm / 1	18 mm / 1

Selection guide



Power monitoring system AC

DIRIS Digiware AC







Current acquisition modules

Application	Metering		Analysis	Monitoring	Analysis	Metering	
							
DIRIS Digiware I	I-30 <i>p. 324</i>	I-31 <i>p. 324</i>	I-35 <i>p. 324</i>	I-43 <i>p. 324</i>	I-45 <i>p. 324</i>	I-60 <i>p. 324</i>	I-61 <i>p. 324</i>
Number of current inputs	3	3	3	4	4	6	6
Metering							
± kWh, ± kvarh, kVAh	•	•	•	•	•	•	•
Load curves		•	•		•		•
Multi-tariff		•	•		•		•
Multi-measurement							
I1, I2, I3, In, ΣP, ΣQ, ΣS, ΣPF	•	•	•	•	•	•	•
P, Q, S, PF per phase		•	•	•	•		•
Predictive power			•		•		
Current unbalance (Inba, Idir, Iinv, Ihom, Inb)			•		•		
Phi, cos Phi, tan Phi			•		•		
Quality							
THDi1, THDi2, THDi3, THDin			•	•	•		
Individual harmonics I (up to 63rd)			•		•		
Crest factors I1, I2, I3, In			•		•		
Overcurrents			•		•		
Alarms							
On threshold			•		•		
Inputs/outputs				2/2	2/2		
History							
Average values			•		•		
Format							
Width/number of modules	18 mm / 1	18 mm / 1	18 mm / 1	27 mm / 1.5	27 mm / 1.5	36 mm / 2	36 mm / 2



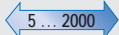
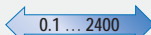

Current acquisition module with integrated sensors

Application	Metering	Analysis
		
DIRIS Digiware S	S-130 <i>p. 320</i>	S-135 <i>p. 320</i>
Number of current inputs	3	3
Basic current I_b	10 A	10 A
Maximum current I_{max}	63 A	63 A
Load type accepted	1P + N 2P / 2P + N 3P / 3P + N	1P + N 2P / 2P + N 3P / 3P + N
Metering		
± kWh, ± kvarh, kVAh	•	•
Multi-tariff (max 8)		•
Load curves		•
Multi-measurement		
I1, I2, I3, In, ΣP, ΣQ, ΣS, ΣPF	•	•
P, Q, S, PF per phase		•
Predictive power		•
Current unbalance (Inba, Inb, Idir, linv, lhom)		•
Phi, cos Phi, tan Phi		•
Quality		
THDi1, THDi2, THDi3, THDin		•
Individual harmonics I (up to 63rd)		•
Crest factors U, V, I		•
K factor		•
Overcurrents		•
Alarms		
Thresholds and combinations		•
Load level		•
Wiring errors		•
Protective device		•
Trends		
Average values		•
Format		
Width	54 mm	54 mm





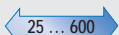
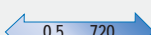

Current sensors

Suitable for new installations match the pitch of protective devices	Solid-core current sensors						
							
	TE-18 <i>p. 328</i>	TE-25 <i>p. 328</i>	TE-35 <i>p. 328</i>	TE-45 <i>p. 328</i>	TE-55 <i>p. 328</i>	TE-90 <i>p. 328</i>	
Nominal current I_n (A) 	5 ... 20	25 ... 63	40 ... 160	63 ... 250	160 ... 630	400 ... 1000	600 ... 2000
Real range covered (A) 	0.1 ... 24	0.5 ... 75.6	0.8 ... 192	1.26 ... 300	3.2 ... 756	8 ... 1200	12 ... 2400
Aperture (mm)	Ø 8.4	Ø 8.4	13.5 x 13.5	21 x 21	31 x 31	41 x 41	64 x 64
Dimensions (mm)	28 x 20 x 45	28 x 20 x 45	25 x 32.5 x 65	35 x 32.5 x 71	45 x 32.5 x 86	55 x 32.5 x 100	90 x 126 x 24.6
Connection	RJ12	RJ12	RJ12	RJ12	RJ12	RJ12	RJ12



For currents above 2000 A, the 5A / RJ12 adapter provides compatibility with 1A or 5A secondary CTs.

Suitable for existing installations	Split-core current sensors			
				
	TR/iTR-10 <i>p. 332</i>	TR/iTR-14 <i>p. 332</i>	TR/iTR-21 <i>p. 332</i>	TR/iTR-32 <i>p. 332</i>
Nominal current I_n (A) 	25 ... 63	40 ... 160	63 ... 250	160 ... 600
Real range covered (A) 	0.5 ... 90	0.64 ... 120	1.26 ... 200	4 ... 720
Aperture (mm)	Ø 10	Ø 14	Ø 21	Ø 32
Dimensions (mm)	26 x 44 x 28	29 x 67 x 28	37 x 65 x 43	53 x 86 x 47
Connection	RJ12	RJ12	RJ12	RJ12

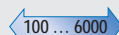
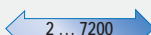
For currents above 600 A, the 5A / RJ12 adapter provides compatibility with 1A or 5A secondary CTs.

Suitable for existing installations with space constraints or with high currents	Flexible current sensors						
							
	TF-40 <i>p. 334</i>	TF-55 <i>p. 334</i>	TF-80 <i>p. 334</i>	TF-120 <i>p. 334</i>	TF-200 <i>p. 334</i>	TF-300 <i>p. 334</i>	TF-600 <i>p. 334</i>
Nominal current I_n (A) 	140 ... 400	150 ... 600	150 ... 600	400 ... 2000	600 ... 4000	1600 ... 6000	1600 ... 6000
Real range covered (A) 	2 ... 480	3 ... 720	3 ... 720	8 ... 2400	12 ... 4800	32 ... 7200	32 ... 7200
Aperture (mm)	Ø 40	Ø 55	Ø 80	Ø 120	Ø 200	Ø 300	Ø 600
Connection	RJ12	RJ12	RJ12	RJ12	RJ12	RJ12	RJ12

Input/output modules

Application	Metering / monitoring / control	
		
DIRIS Digiware IO	IO-10 <i>p. 340</i>	IO-20 <i>p. 340</i>
Number of digital inputs/outputs	4/2	
Number of analogue inputs	2	
Format		
Width/number of modules	18 mm / 1	18 mm / 1

DIRIS Digiware D

Multi-point display and communication gateway
for the DIRIS Digiware system



Configuration
with Easy Config System.



diris-dw_151

DIRIS Digiware D-50/D-70
Centralisation and display of data

The solution for

- > Data centre
- > Healthcare
- > Energy
- > Industry



Strong points

- > Plug & Play
- > Multi-circuit
- > Embedded webserver
- > Advanced connectivity
- > Cybersecurity
- > Email notifications

Compliance with standards

- > IEC 62974-1
(Energy server)



- > IEC 62443
(Cybersecurity)



- > UL 61010
Guide FTRZ/PICQ
File E257746



- > FCC
- > IC

Create your project

- > Find the best DIRIS Digiware configuration:
www.meter-selector.com



Function

With DIRIS Digiware D-50 and D-70 remote displays, you can show data locally from DIRIS Digiware modules and centralise 24 VDC power and communication at a single point. The D-50 and D-70 displays also act as the Ethernet gateway for all the devices connected on the Digiware or RS485 bus, and have an embedded web server to configure the network parameters and remotely display measurement data.

Advantages

Plug & Play

- Direct Digiware and RS485-to-Ethernet gateway.
- Automatic detection of connected devices.
- Easy setup.
- Safety Extra-Low Voltage 24 VDC power supply.

Multi-circuit

Display measurement data from up to 196 circuits on the same screen.
10 capacitive hotkeys to easily select circuits and browse/view simple data.

Embedded webserver

A WEB-CONFIG is embedded in the D-50 display to configure the communication architecture.

WEBVIEW-M is embedded in the D-70 display to view measurements and consumption remotely and licence-free.

Advanced connectivity

- Ethernet output for communication using multiple protocols: Modbus TCP, BACnet IP and SNMP v1, v2, v3 (encrypted) to suit any metering and power monitoring application.
- Options include configuring as an RS485 slave to communicate measurement data to a second PLC.

Displays D-50 and D-70 also feature:

- bluetooth connectivity for gathering and viewing data from environmental sensors;
- added memory for connected devices;
- automated export of data to the FTP(S) server;
- email notifications if there is an alarm on one of the connected devices (SMTPS);
- automated updates on all the system devices via SNMP.

Cybersecurity

D-50 and D-70 displays include advanced cybersecurity features in compliance with IEC 62443 standards, to protect the transmission of data and reduce the risk of cyberattacks:





- customised security policy (blocking or restricting certain protocols and services);
- HTTPS secured navigation using TLS/SSL certificates;
- push data transfer (FTPS, SMTPS);
- firewalls and whitelist protocols to guard against denial-of-service attacks.

Email notifications

D-50 and D-70 displays can send email notifications in case of an alarm.

General characteristics

- 96 x 96 mm format with 10 hotkeys.
- 24 VDC power supply
- Modbus RTU/TCP, BACnet IP, SNMP v1, v2, v3 & Traps, HTTPS, FTPS, SMTPS, SNMP, DHCP
- Displays up to 32 devices (max. 196 circuits)
- Free embedded web-based software VFR

Application	Control and power supply interface			
				
DIRIS Digiware	D-50	D-70	D-50 Bluetooth	D-70 Bluetooth
Digiware input	•	•	•	•
RS485 input	•	•	•	•
RS485 output	•	•	•	•
Ethernet output	Modbus BACnet IP SNMP v1, v2, v3	Modbus BACnet IP SNMP v1, v2, v3	Modbus BACnet IP SNMP v1, v2, v3	Modbus BACnet IP SNMP v1, v2, v3
Bluetooth			•	•
Webserver	WEB-CONFIG	WEBVIEW-M	WEB-CONFIG	WEBVIEW-M

Functions



WEBVIEW-M

Embedded web server in the DIRIS Digiware D-70 display

WEBVIEW-M allows the display and remote monitoring of all the electric parameters measured by up to 32 devices. They are displayed in the form of overview screens, graphs or tables for clear and user-friendly analysis.

Access to WEBVIEW is made by a web browser on a PC or tablet and offers multiple features such as the automatic export of data via FTPS or e-mail notification in the presence of alarms (SMTPS).

The Photoview application is available via the WEBVIEW interface embedded in the DIRIS Digiware D-70 display. It allows the display of electrical quantities on a customised background picture such as a cabinet, a wiring diagram or the map of a site.

Accessories

DIN rail mounting kit

The accessory allows you to install the DIRIS Digiware D-50/D-70 display on a DIN rail.

This kit is not included with the displays and must be ordered separately.



DIRIS Digiware D

Multipoint display and communication gateway

for the DIRIS Digiware system

Dimensions (mm)

DIRIS Digiware D-50/D-70

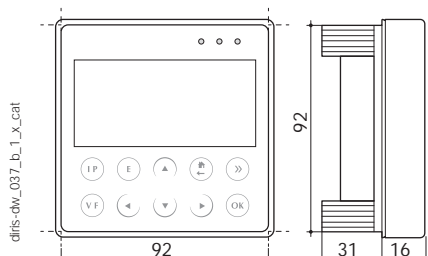

Configuration

Equipment consumption

Product	Power delivered (W)	Power consumed (W)
Power supply		
P15 100-240 VAC / 24 VDC	15	
P30 100-240 VAC / 24 VDC	20	
Cables		
50 metre package		1.5
System interfaces		
DIRIS Digiware D-50/D-70		2.5
DIRIS Digiware C-31		0.8
Module voltage		
DIRIS Digiware U-xx		0.72
DIRIS Digiware U-3xdc		0.6
Current modules		
DIRIS Digiware I-3x		0.52
DIRIS Digiware I-4x		1.125
DIRIS Digiware I-6x		0.7
DIRIS Digiware I-3xdc (+ 3 DC current sensors)		2
DIRIS Digiware S-xx		0.35
Input/output modules		
DIRIS Digiware IO-10/IO-20		0.5
Repeater		
DIRIS Digiware C-32		1.5

Calculation rules for the max. number of products on the Digiware Bus

The total power consumed by the equipment connected to the Digiware Bus must not exceed the power from the 24 VDC supply.

The power supply must not exceed 20 W/70 °C or 27 W/40 °C.

Size with P15 power supply (ref: 4829 0120) delivering 15 W

For example, it is possible to use

- 1 DIRIS Digiware D-50 display (2.5 W)
- 1 DIRIS Digiware voltage module U-xx (0.72 W)
- 50 metres of cable (1.5 W)

and

- 19 DIRIS Digiware current modules I-3x (19 x 0.52 = 9.9 W)
- ⇒ **Total power = 14.845 W**

or

- 9 DIRIS Digiware current modules I-4x (9 x 1.125 = 10.125 W)
- ⇒ **Total power = 14.345 W.**

Size with a 24 VDC power supply delivering a maximum of 20 W

(Power supply P30 ref: 4729 0603)

For example, it is possible to use

- 1 DIRIS Digiware D-50 display (2.5 W)
- 1 DIRIS Digiware voltage module U-xx (0.72 W)
- 50 metres of cable (1.5 W)

and

- 29 DIRIS Digiware current modules I-3x (29 x 0.52 = 15.1 W)
- ⇒ **Total power = 19.82 W**

or

- 13 DIRIS Digiware current modules I-4x (13 x 1.125 = 14.625 W)
- ⇒ **Total power = 19.345 W.**

Repeater

Whenever the power consumption is higher than 20 W or the distance is greater than 100 m, a DIRIS Digiware C-32 repeater is required.

In a DIRIS Digiware system, a maximum of 2 repeaters may be used.

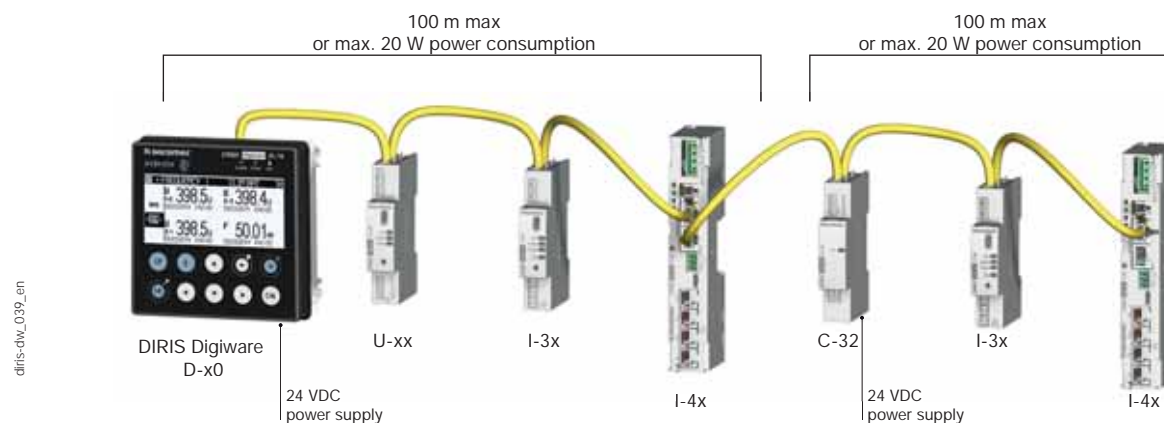

Connections

RS485 slave mode

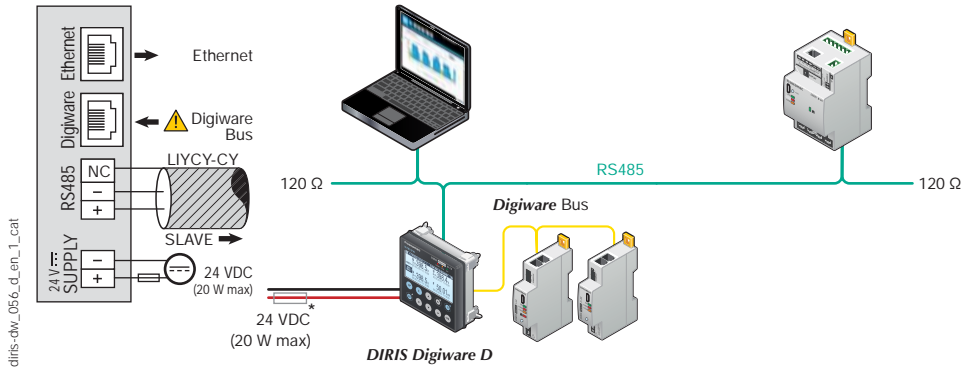

(*) 1A / 24 VDC fuse protection is recommended if the 24 VDC power supply is not provided by Socomec.

RS485 master mode

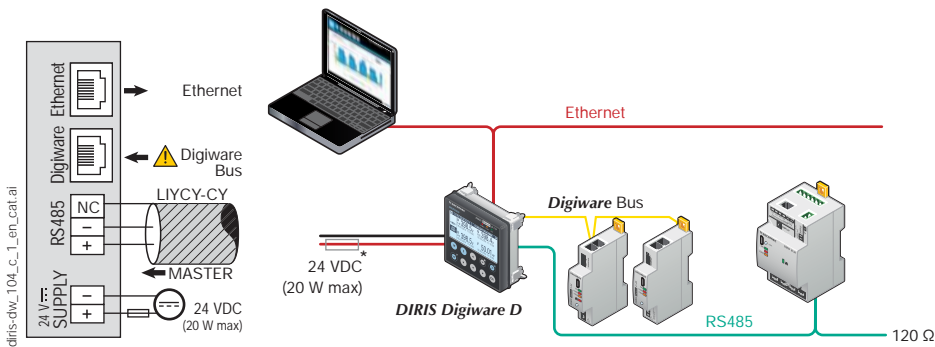

(*) 1A / 24 VDC fuse protection is recommended if the 24 VDC power supply is not provided by SOCOMEC.

DIRIS Digiware D

Multipoint display and communication gateway

for the DIRIS Digiware system

Technical characteristics

Mechanical characteristics	
Type of screen	Capacitive touch-screen technology, 10 keys
Screen resolution	350 x 160 pixels
Front panel protection index	IP65
Communication	
Ethernet RJ45 10/100 Mbs	Gateway function (D-50/D-70): Modbus TCP BACnet IP SNMP v1, v2, v3
RJ45 Digiware	Control and power supply interface function
RS485 2-3 wires	Modbus RTU communication function Configurable as input or output
USB	Upgrade and configuration via type B micro USB connector
Electrical characteristics	
Power supply	24 VDC \pm 15 %
Power consumption	2,5 VA
Battery lifetime	10 years

Environmental specifications	
Storage temperature	-20 to +70 °C
Operating temperature	-10 to +55 °C
Humidity	95% at 40 °C
Installation category, degree of pollution	CAT III, 2
Ports	
Digiware	Input
RS485	Input/Output
Ethernet	Output

References

DIRIS Digiware		Reference
D-50	Multipoint display, Ethernet & RS485 output + WEB-CONFIG	4829 0204
D-70	Multipoint display, Ethernet & RS485 output + WEBVIEW-M	4829 0203
D-50 Bluetooth	Multipoint display, Ethernet & RS485 output + WEB-CONFIG + Bluetooth	4829 0206
D-70 Bluetooth	Multipoint display, Ethernet & RS485 output + WEBVIEW-M + Bluetooth	4829 0207
Power supply		Reference
P15	Power supply 100-240 VAC/ 24 VDC 15 W	4829 0120
P30	Power supply 100-240 VAC/ 24 VDC 20 W	4729 0603
Digiware connection cables		Reference
RJ45 cables for Digiware Bus	Length 0.06 m	4829 0189
	Length 0.10 m	4829 0181
	Length 0.20 m	4829 0188
	Length 0.50 m	4829 0182
	Length 1 m	4829 0183
	Length 2 m	4829 0184
	Length 3 m	4829 0190
	Length 5 m	4829 0186
	Length 10 m	4829 0187
50 m reel + 100 connectors		4829 0185
Termination for Digiware Bus (supplied with interfaces D)		4829 0180
USB configuration cable		4829 0050
Accessories	To be ordered in multiples of	Reference
Repeater C-32		4829 0103
Fuse holder to protect voltage inputs (type RM) 1 pole + neutral	4	5701 0017
gG 10x38 0.5 A fuses	10	6012 0000
DIN rail mounting kit for D-50 and D-70 displays	1	4829 0230
Door mounting kit DIN 144 x 96 mm		4729 0290
IP 65 flexible cover for 144 x 96 mm door mounting frame		4729 0291

Expert Services



To constantly ensure a functional, accurate and reliable energy monitoring system, Socomec offers a wide range of services:

- Integration of units
 - System audits
 - Commissioning
 - Staff training
- What's more, ideal for ISO 50001 sites (regular checks):
- Verification of 3% measurement consistency
 - Verification of 0.2% measurement precision

DIRIS Digiware C-31

Control and power supply interface



DIRIS Digiware C-31
Centralisation



Configuration
with Easy Config System.

Function

For applications without a local display, the DIRIS Digiware C-31 interface centralises all your system data and provides all this information to external software or a PLC via RS485. The DIRIS Digiware C-31 interface is supplied with 24 VDC.

Advantages

Compact

Centralise your measurement data on a single module without a local screen, for a complete system:

- Single auxiliary 24 VDC power supply
- A single RS485 communication

24 VDC Safety Extra Low Voltage power supply

- No dangerous voltage
- The power supply feeds the entire system through the Digiware bus

The solution for

- > Data centre
- > Healthcare
- > Energy
- > Industry



Strong points

- > Compact
- > 24 VDC Safety Extra-Low Voltage power supply

Compliance with standards

- > IEC 61557-12



- > UL 61010
Guide FTRZ/PICQ
File E257746



Create your project

- > Find the best DIRIS Digiware configuration:
www.meter-selector.com

METER SELECTOR
DIGITAL TOOL AVAILABLE

Dimensions (mm)

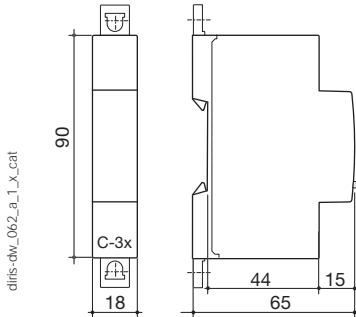

Configuration

Equipment consumption

Product	Power delivered (W)	Power consumed (W)
Power supply		
P15 100-240 VAC / 24 VDC	15	
P30 100-240 VAC / 24 VDC	20	
Cables		
50 metre package		1.5
System interfaces		
DIRIS Digiware D-50/D-70		2.5
DIRIS Digiware C-31		0.8
Module voltage		
DIRIS Digiware U-xx		0.72
DIRIS Digiware U-3xdc		0.6
Current modules		
DIRIS Digiware I-3x		0.52
DIRIS Digiware I-4x		1.125
DIRIS Digiware I-6x		0.7
DIRIS Digiware I-3xdc (+ 3 DC current sensors)		2
DIRIS Digiware S-xx		0.35
Input/output modules		
DIRIS Digiware IO-10/IO-20		0.5
Repeater		
DIRIS Digiware C-32		1.5

Calculation rules for the max. number of products on the Digiware Bus

The total power consumed by the equipment connected to the Digiware Bus must not exceed the power from the 24 VDC supply.

The power supply must not exceed 20 W/70 °C or 27 W/40 °C.

Size with P15 power supply (ref: 4829 0120) delivering 15 W

For example, it is possible to use

- 1 DIRIS Digiware D-50 display (2.5 W)
- 1 DIRIS Digiware voltage module U-xx (0.72 W)
- 50 metres of cable (1.5 W)

and

- 19 DIRIS Digiware current modules I-3x (19 x 0.52 = 9.9 W)

⇒ **Total power = 14.845 W**

or

- 9 DIRIS Digiware current modules I-4x (9 x 1.125 = 10.125 W)

⇒ **Total power = 14.345 W.**

Size with a 24 VDC power supply delivering a maximum of 20 W

(Power supply P30 ref: 4729 0603)

For example, it is possible to use

- 1 DIRIS Digiware D-50 display (2.5 W)
- 1 DIRIS Digiware voltage module U-xx (0.72 W)
- 50 metres of cable (1.5 W)

and

- 29 DIRIS Digiware current modules I-3x (29 x 0.52 = 15.1 W)

⇒ **Total power = 19.82 W**

or

- 13 DIRIS Digiware current modules I-4x (13 x 1.125 = 14.625 W)

⇒ **Total power = 19.345 W.**

Repeater

Whenever the power consumption is higher than 20 W or the distance is greater than 100 m, a DIRIS Digiware C-32 repeater is required.

In a DIRIS Digiware system, a maximum of 2 repeaters may be used.

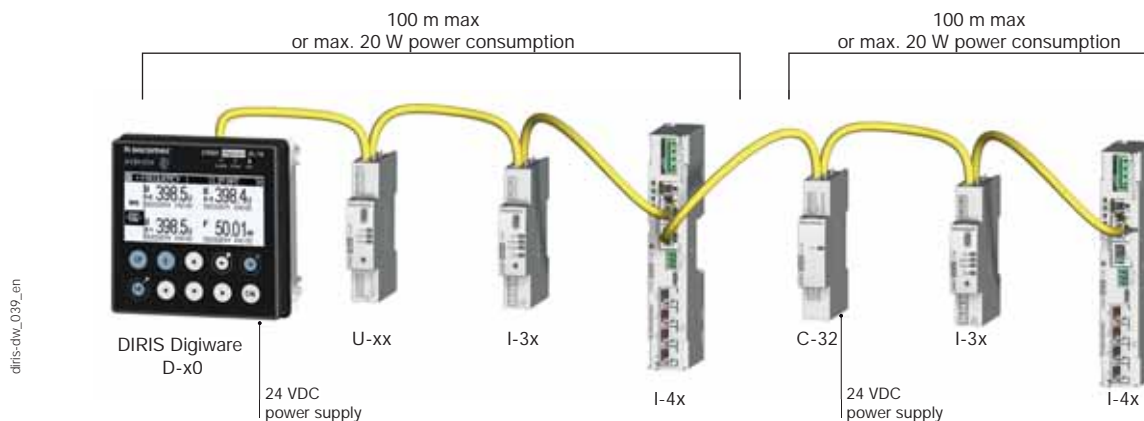

diris-dw_039_en

DIRIS Digiware C-31

Control and power supply interface

Connections

DIRIS Digiware C-31

Power supply



Digiware bus



Communication

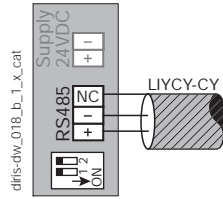

DIRIS Digiware C-32

Power supply

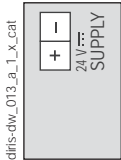

Digiware bus

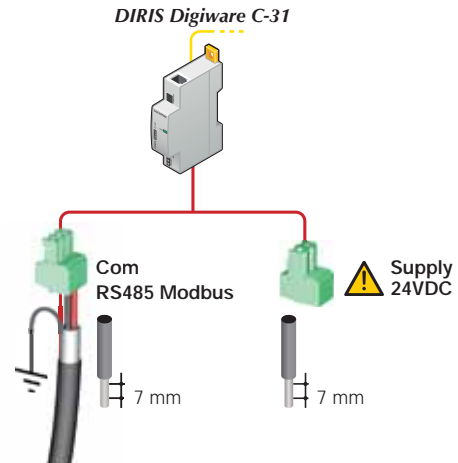
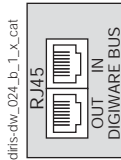

dfris-dw_057_a_1_en_cat

Technical characteristics

Electrical characteristics

Input voltage	24 VDC ± 20% - 20 W max
Connection	Removable screw terminal block, 2 positions, stranded or solid 0.2-2.5 mm ² cable
P15 power supply	Technical characteristics: 100-240 VAC/ 24 VDC - 0.63 A - 15 W Modular format - Dimensions (H x L): 90 x 36 mm

Communication specifications

Digiware Bus	
Function	Connection between DIRIS Digiware modules
Cable type	Specific SOCOMEC cable with RJ45 connections
RS485	
Connection type	2 to 3 half duplex wires
Protocol	Modbus RTU
Baudrate	9600 to 115 200 bauds
Function	Data configuration and reading
Location	Single-point on DIRIS Digiware C

Mechanical features

Casing type	DIN-rail mounting module and base
Casing protection index	IP20 / IK06
Front panel protection index	IP40 on the nose in modular assembly / IK06

Environmental specifications

Ambient operating temperature	-10 to +70 °C
Storage temperature	-25 to +70 °C
Operating humidity	55 °C / 97% HR
Operating altitude	< 2000 m

References

DIRIS Digiware		Reference
C-31	System interface - no display, RS485 output	4829 0101
C-32	Repeater	4829 0103

Expert Services



EXPERT
SERVICES

To constantly ensure a functional, accurate and reliable energy monitoring system, Socomec offers a wide range of services:

- Integration of units
- System audits
- Commissioning

- Staff training

What's more, ideal for ISO 50001 sites (regular checks):

- Verification of 3% measurement consistency
- Verification of 0.2% measurement precision

DIRIS Digiware M

Multi-protocol communication gateways
for the DIRIS Digiware system



DIRIS Digiware M-50 - M-70 gateway

Function

The DIRIS Digiware M-50 and M-70 communication gateways are the access point for the DIRIS Digiware system, centralising the 24 VDC power supply and communication in one single point.

The M-50 and M-70 act as the Ethernet gateway for all the devices connected on the Digiware or RS485 bus, and integrate a web server to configure the network parameters and to remotely display measurement data.

The M-50 and M-70 gateways offer a wide range of functionalities, including:

- Bluetooth connectivity to collect data from environmental sensors,
- memory extension for connected devices,
- automatic export of logged consumption and data to an FTP(S) server,
- notification emails if there is an alarm on one of the connected devices (SMTPS),
- automatic time synchronisation of all connected devices via SNTP.

Advantages

Plug & Play

- Direct Digiware and RS485 to Ethernet gateway.
- Automatic detection of connected devices.
- Easy setup.
- Safety Extra Low Voltage 24 VDC power supply.

Advanced connectivity

- Ethernet output for communication using multiple protocols: Modbus TCP, BACnet IP and SNMP v1, v2, v3 (encrypted) to suit any metering and power monitoring application.
- Possible to configure as RS485 slave to communicate measurement data to a second PLC, for example.

Embedded web server

A WEB-CONFIG is embedded in the M-50 gateway to configure the communication architecture.

WEBVIEW-M is embedded in the M-70 gateway and available without license fees to visualise measurements and consumption remotely.

General characteristics

- 24 VDC power supply.
- Modbus RTU/TCP, BACnet IP, SNMP v1, v2, v3 & Traps, HTTPS, FTPS, SMTPS, SNTP, DHCP.
- Up to 32 devices (max. 196 circuits) displayed.
- Free embedded web-based software.

The solution for

- > Data centre
- > Building
- > Industrial process



Strong points

- > Plug & Play
- > Advanced connectivity
- > Embedded web server
- > Cyber security
- > Email notifications



RJ45 (Digiware bus) cables are available.

Compliance with standards

- > IEC 62974-1 (Energy Server)
- > IEC 62443 (Cyber security)



- > UL 61010 Guide FTRZ/PICQ File E257746



- > FCC
- > IC



Create your project

- > Find the best DIRIS Digiware configuration: www.meter-selector.com



Application	Multi-protocol communication gateway	
		
DIRIS Digiware M	M-50	M-70
Digiware bus input	•	•
RS485	Input/output ⁽¹⁾	Input/output ⁽¹⁾
Ethernet output	•	•
Compatible protocols	Modbus RTU Modbus TCP BACnet IP SNMP v1, v2, v3, Traps	Modbus RTU Modbus TCP BACnet IP SNMP v1, v2, v3, Traps
Bluetooth	•	•
FTP(S) (automatic data export)	•	•
SMTP(S) (email notifications in case of alarm)	•	•
SNTP (time synchronisation)	•	•
Web Server	WEB-CONFIG	WEBVIEW-M

(1) The gateways can be configured as Modbus master (RS485 input) or slave (RS485 output).

Architecture

MEASURE

COLLECT

VISUALISE

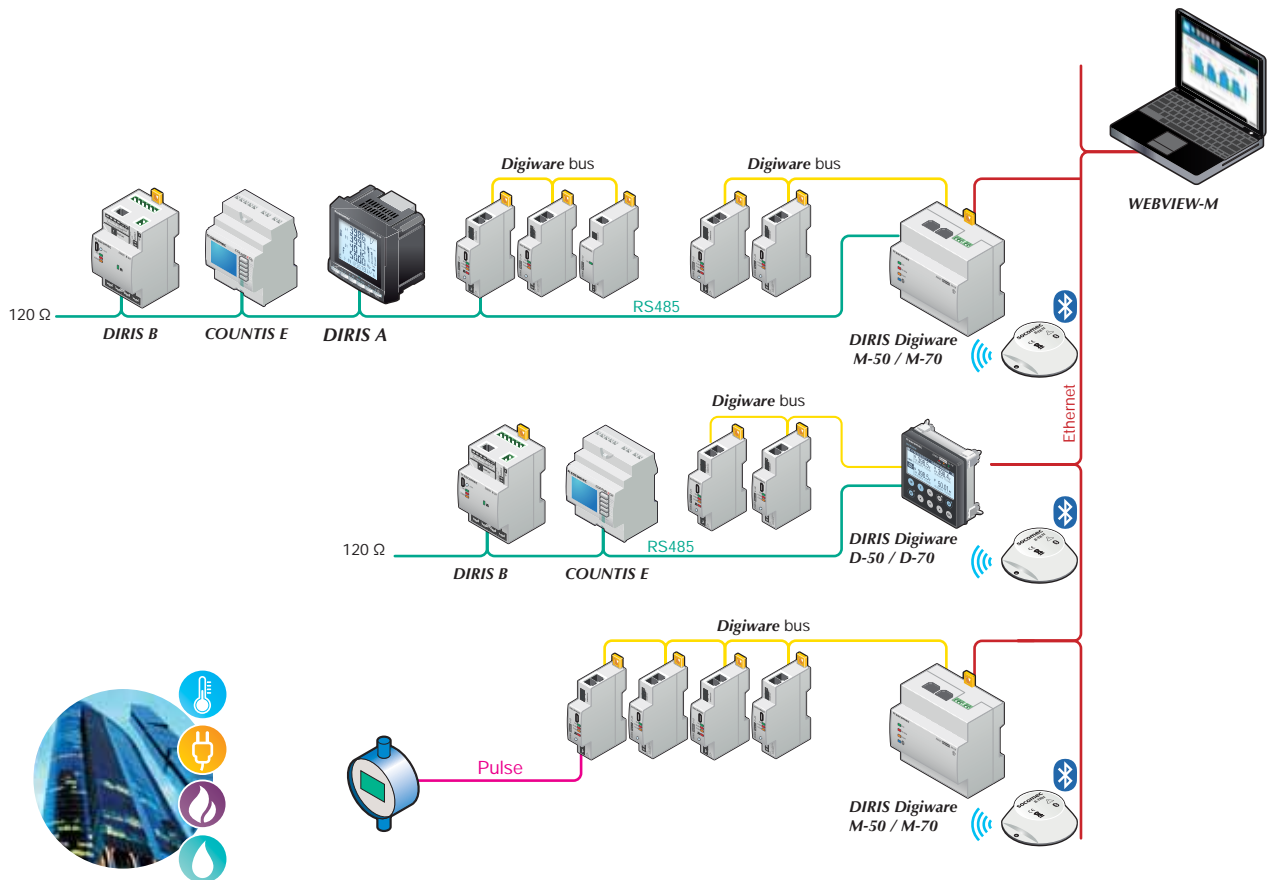

diris-dw_169

DIRIS Digiware M

Multi-protocol communication gateways
for the DIRIS Digiware system

Embedded webserver

WEB-CONFIG (M-50)

The M-50 gateway includes a WEB-CONFIG allowing you to:

- configure the device hierarchy and data access,
- block or restrict access to certain peripherals, protocols or services.

WEBVIEW-M (M-70)

In addition to the WEB-CONFIG, the M-70 gateway allows a remote visualisation of data on the embedded WEBVIEW-M software, available without licence fees.

- Real-time measurements.
- On-going and terminated alarms.
- Consumption curves and load curves per load or usage.
- Photoview: displays electrical parameters on a customised background such as a site map, an electrical diagram or a panel picture to provide an overview of your electrical installation.

Data storage

These gateways extend the memory of connected devices so you can log a year's worth of measurements, load curves and consumption curves.



Configuration

Device consumption

Device	Power supplied (W)
Power supply	
P15 100-240 VAC / 24 VDC	15
P30 100-240 VAC / 24 VDC	20
Device	Power consumed (W)
Cables	
50-metre package	1.5
System interfaces	
DIRIS Digiware C-31	0.8
DIRIS Digiware D-50/D-70	2.5
DIRIS Digiware M-50/M-70	2.5
Voltage module	
DIRIS Digiware U-xx	0.72
DIRIS Digiware U-3xdc	0.6
Current modules	
DIRIS Digiware I-3x	0.52
DIRIS Digiware I-4x	1.125
DIRIS Digiware I-6x	0.7
DIRIS Digiware I-3xdc (+ 3 DC current sensors)	2
DIRIS Digiware S-xx	0.35
Input/output modules	
DIRIS Digiware IO-10/IO-20	0.5
Repeater	
DIRIS Digiware C-32	1.5

Calculation rules for the max. number of devices on the Digiware bus

The total power consumed by the devices connected to the Digiware bus must not exceed the power from the 24 VDC supply.

The power supply must not exceed 20 W / 70°C or 27 W / 40°C.

Size with P15 power supply (ref. 4829 0120) delivering 15 W

For example, it is possible to use

- 1 DIRIS Digiware M-50 gateway (2.5 W)
- 1 DIRIS Digiware voltage module U-xx (0.72 W)
- 50 metres of cable (1.5 W)

and

- 29 DIRIS Digiware current modules S-xx ($29 \times 0.35 = 10.15$ W)
⇒ **Total power = 14.87 W**

or

- 9 DIRIS Digiware current modules I-4x ($9 \times 1.125 = 10.125$ W)
⇒ **Total power = 14.845 W**

Size with a 24 VDC power supply delivering a maximum of 20 W (P30 ref. 4729 0603)

Possible options include:

- 1 DIRIS Digiware M-50 gateway (2.5 W)
- 1 DIRIS Digiware voltage module U-xx (0.72 W)
- 50 metres of cable (1.5 W)

and

- 29 DIRIS Digiware current modules I-3x ($30 \times 0.52 = 15.08$ W)
⇒ **Total power = 19.8 W**

or

- 14 DIRIS Digiware current modules I-4x ($13 \times 1.125 = 15.72$)
⇒ **Total power = 19.345 W**

Repeater

With power consumptions higher than 20 W or distances greater than 100 m, a DIRIS Digiware C-32 repeater is required.

In a DIRIS Digiware system, a maximum of 2 repeaters may be used.

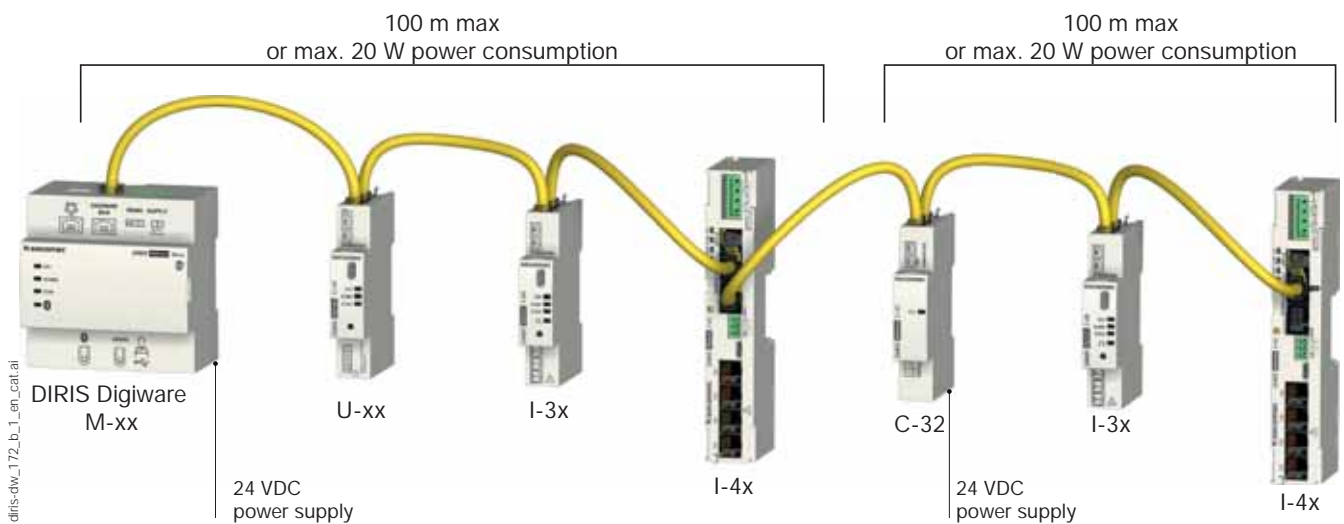

DIRIS Digiware M

Multi-protocol communication gateways
for the DIRIS Digiware system

Dimensions (in/mm)

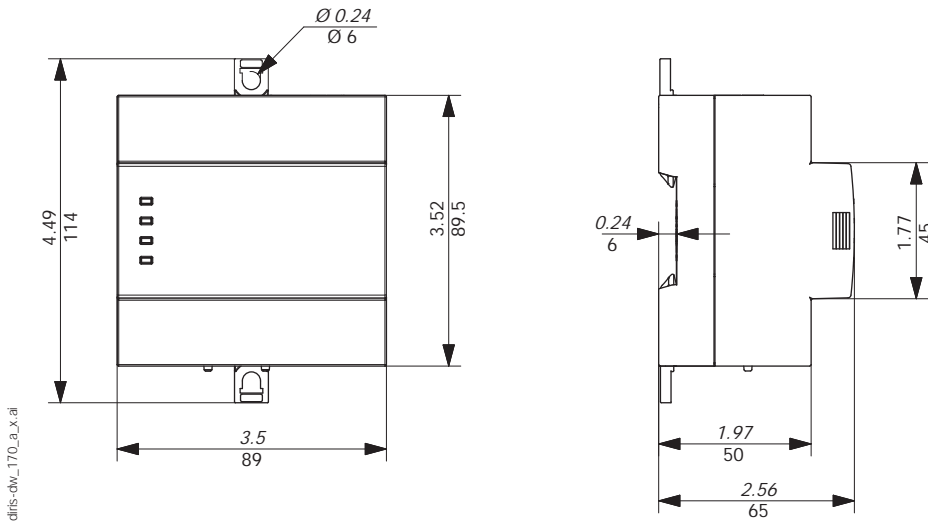

Technical characteristics

Electrical characteristics

Power supply	24 VDC \pm 10 % - 20 W max
Power consumption	2.5 W
Battery life	10 years

Mechanical characteristics

Casing type	DIN-rail or back plate mounting
Weight	166 g
Protection degree	IP40 on the nose in modular assembly

Environmental characteristics

Ambient operating temperature	-10 ... +55°C
Storage temperature	-25 ... +70°C
Operating humidity	95% at 40°C
Operating altitude	< 2000 m

Communication characteristics

Ethernet RJ45 10/100 Mbps	Gateway function (M-50/M-70): Modbus TCP BACnet IP SNMP v1, v2, v3, Traps
---------------------------	--

Digiware bus

Function	2 to 3 half duplex wires
Cable type	Specific Socomec cable with RJ45 connection

RS485

Connection type	24 VDC +10 % / -20%
Protocol	Modbus RTU
Baudrate	9600 bds (max. 10 devices) 38400 bds - 115200 bds (max. 32 devices)
Function	Communication with PMD and meters or energy management systems (in RS485 slave mode)

USB

Protocol	Modbus RTU over USB
Function	Configuration of gateway and connected PMDs/meters

References

DIRIS Digiware		Reference
M-50	Multi-protocol Ethernet gateway	4829 0219
M-70	Multi-protocol Ethernet gateway with embedded WEBVIEW-M web server	4829 0220
M-50 Bluetooth	Multi-protocol Ethernet gateway (with Bluetooth connectivity)	4829 0221
M-70 Bluetooth	Multi-protocol Ethernet gateway with embedded WEBVIEW-M web server (with Bluetooth connectivity)	4829 0222
Power supply		Reference
P15	Power supply 100-240 VAC/ 24 VDC 15 W	4829 0120
P30	Power supply 100-240 VAC/ 24 VDC 20 W	4729 0603
Digiware connection cables		Reference
RJ45 cables for Digiware bus	Length 0.06 m	4829 0189
	Length 0.10 m	4829 0181
	Length 0.20 m	4829 0188
	Length 0.50 m	4829 0182
	Length 1 m	4829 0183
	Length 2 m	4829 0184
	Length 3 m	4829 0190
	Length 5 m	4829 0186
	Length 10 m	4829 0187
	50 m reel + 100 connectors	4829 0185
Terminal for Digiware bus (spare part ref. only as already supplied with M-50 and M-70 gateways)		4829 0180
USB configuration cable		4829 0050
Accessories	Available for order in multiples of	Reference
Fuse circuit breakers to protect voltage inputs (type RM) 1 pole + neutral	4	5701 0017
gG 10x38 0.5 A fuses	10	6012 0000

Expert Services

Need help to integrate this system in your network?

No problem for our "Expert Services" team. They will fully integrate all your SOCOMEC devices, **audit** your system, **commission** selected equipment and **train** your staff on its use. For further information, please contact your nearest SOCOMEC branch.

DIRIS Digiware Uac

Voltage acquisition module



diris-dw_005_a_cat

DIRIS Digiware U-10ac/U-20ac/ U-30ac



Configuration
with Easy Config System.

Function

The **DIRIS Digiware Uac** module measures voltage for the entire system. This pools together all voltage measurements.

The Digiware RJ45 Bus allows you to pass voltage measurements as well as power supply and communication to all connected products.

Advantages

- 1 single voltage measurement point for the entire system.
- Single point of protection for voltage measuring.
- A complete, dedicated solution:
 - metering,
 - monitoring voltage,
 - quality analysis of the supplied voltage.
- No hazardous voltage on cabinet doors.
- Adapted to all types of network: single-phase, three-phase.

The solution for

- > Industry
- > Building
- > Infrastructure
- > Data center



Strong points

- > 1 single voltage measurement point for the entire system
- > Plug & Play
- > Compact



RJ45 (Digiware Bus) cables are available.

Conformity to standards

- > IEC 61557-12



- > ISO 14025





- > UL



Create your project

- > Find the best DIRIS Digiware configuration:
www.meter-selector.com



Application	Voltage measurement module	
	Metering	Analysis
		
	U-10ac	U-30ac
DIRIS Digiware Uac		
Multi-measurement		
U12, U23, U31, V1, V2, V3, f	•	•
U system, V system		•
Ph/N unbalance		•
Ph/Ph unbalance		•
Quality analysis		
THDv1, THDv2, THDv3, THDu12, THDu23, THDu31		•
Individual harmonics U & V (up to 63rd)		•
Voltage dips, swells and interruptions (EN 50160)		•
Alarms		
On threshold		•
History of average values		
45 days (max)		•
Format		
Width/number of modules	18 mm / 1	18 mm / 1

Dimensions (mm)

DIRIS Digiware Uac

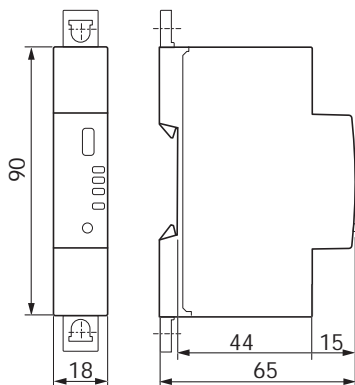

diris-dw_059_b_1_x_cat

Specifications

Measuring characteristics

Voltage measurement - DIRIS Digiware Uac

Characteristics of the network measured	50-300 VAC (Ph/N) - 87-520 VAC (Ph/Ph) - CAT III
Frequency range	45 ... 65 Hz
Frequency accuracy	Class 0.02
Network type	Single-phase/ Two-phase / Two-phase with neutral / Three-phase / Three-phase with neutral
Measurement by voltage transformer	Primary: 400 000 VAC Secondary: 60, 100, 110, 173, 190 VAC
Input consumption	≤ 0.1 VA
Permanent overload	300 VAC Ph/N
Accuracy of voltage measurement	Class 0.2
Connection	Removable screw terminal block, 4 positions, stranded or solid 0.2 ... 2.5 mm ² cable

Communication specifications

USB

Protocol	Modbus RTU on USB
Function	Configuration of DIRIS Digiware U and I modules
Location	On each DIRIS Digiware U and I measurement module
Connection	Type B micro USB connector

References

Dirigware connection cables	Reference	
RJ45 cables for Digiware Bus	Length 0.06 m	4829 0189
	Length 0.10 m	4829 0181
	Length 0.20 m	4829 0188
	Length 0.50 m	4829 0182
	Length 1 m	4829 0183
	Length 2 m	4829 0184
	Length 3 m	4829 0190
	Length 5 m	4829 0186
	Length 10 m	4829 0187
Reel 50 m + 100 connectors	4829 0185	
Replacement reference: Digiware bus terminating resistor (supplied with C and D devices)	4829 0180	
USB configuration cable	4829 0050	

DIRIS Digiware		Reference
U-10ac	Metering	4829 0105
U-30ac	Analysis	4829 0102

Accessories	To be ordered in multiples of	Reference
Fuse holder to protect voltage inputs (type RM) 3 pole + neutral	3	5701 0019
gG 10x38 0.5 A fuses	10	6012 0000

DIRIS Digiware S

Current acquisition module with integrated sensors



diris-dw_127.psd

DIRIS Digiware S



Configuration
with Easy Config System.

Function

DIRIS Digiware S current acquisition modules have 3 integrated current sensors for the measurement of electrical circuits up to 63 A.

Positioned directly above or below the protective devices, they are associated with the DIRIS Digiware U voltage measurement module to measure consumption, and to monitor the electrical installation and the quality of the power supply.

Advantages

Plug & Play

- Save wiring time: the current sensors are integrated in the module.
- Quick RJ45 connection between modules.
- Positioning possible upstream or downstream of the protective device.

Multi-circuit

Multiple DIRIS Digiware S modules can be used within the measurement system enabling the monitoring of a large number of loads.

Functional diagram

Downstream



diris-dw_130.eps

Upstream



diris-dw_131.eps

The DIRIS Digiware S measurement module can be mounted upstream or downstream of the protective device solving issues of space constraints.

The solution for

Distribution boards in:

- > Data center
- > Building
- > Industry



Strong points

- > Plug & Play
- > Multi-circuit
- > Compact



RJ45 (Digiware Bus) cables
are available.

Integrated technologies



PreciSense



AutoCorrect



VirtualMonitor

For more information see our website
www.socomec.com

Compliance with standards

- > IEC 61557-12





- > ISO 14025



- > UL 257746



Application	Current measurement module with integrated sensors	
	Metering	Analysis
		
DIRIS Digiware S	S-130	S-135
Number of current inputs	3	3
Basic current I_b	10 A	10 A
Maximum current I_{max}	63 A	63 A
Load type accepted	1P + N 2P / 2P + N 3P / 3P + N	1P + N 2P / 2P + N 3P / 3P + N
Metering		
\pm kWh, \pm kvarh, kVAh	•	•
Multi-tariff (max 8)		•
Load curves		•
Multi-measurement		
$I_1, I_2, I_3, I_n, \Sigma P, \Sigma Q, \Sigma S, \Sigma PF$	•	•
P, Q, S, PF per phase		•
Predictive power		•
Current unbalance ($I_{nba}, I_{nb}, I_{dir}, I_{inv}, I_{hom}$)		•
Phi, cos Phi, tan Phi		•
Quality		
THDi1, THDi2, THDi3, THDin		•
Individual harmonics I (up to 63rd)		•
Crest factors U, V, I		•
K factor		•
Overcurrents		•
Alarms		
Thresholds and combinations		•
Wiring errors		•
Protective device	•	•
Trends		
Average values		•
Format		
Width	54 mm	54 mm

Mounting accessories

Temporary MCB insert
(for use during panel assembly)

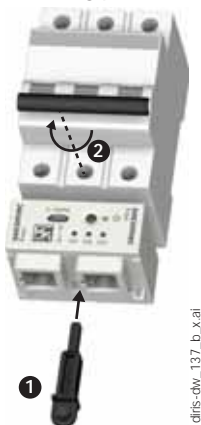

DIN rail and back plate mounting



Cable tie tether



DIRIS Digiware S

Current acquisition module with integrated sensors

Dimensions (mm)

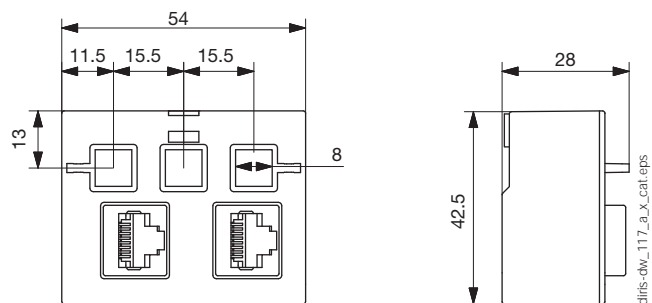

Connections

Current is measured by the integrated inputs I01, I02 and I03 on the DIRIS Digiware S module.

3P+N - 3CT

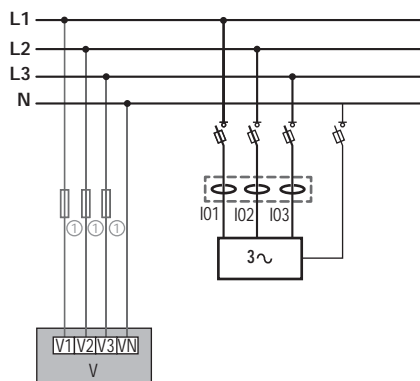

diris-dw_118_a_x_cat.ai

3P - 3CT

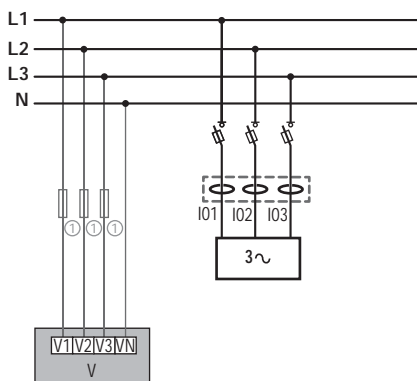

2P+N - 2CT & 2P+N - 1CT

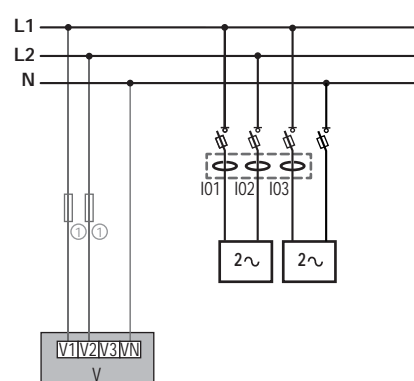

diris-dw_119_a_x_cat.ai

diris-dw_120_a_x_cat.ai

1P+N - 1CT (3x)

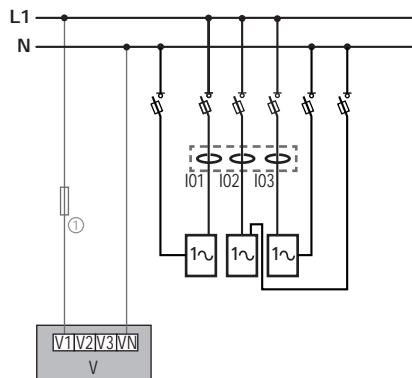

diris-dw_121_a_x_cat.ai

3P+N - 1CT (3x)

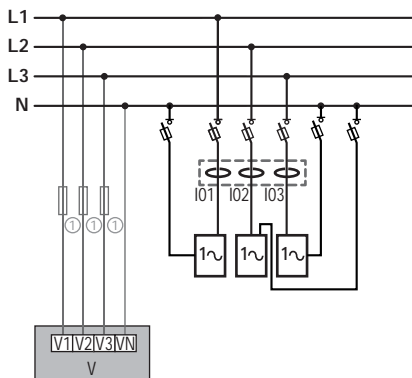

diris-dw_122_a_x_cat.ai

2P+N - 1CT (3x)

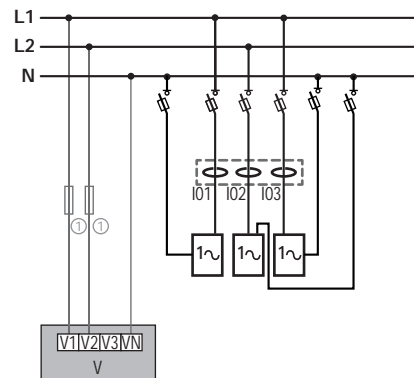

diris-dw_123_a_x_cat.ai



Technical characteristics

Measurement characteristics

Measurement of current	
Number of current inputs	3
Associated current sensors	Integrated in the product
Basic current I _b	10 A
Maximum current I _{max}	63 A
Current measurement accuracy	Class 0.5 IEC 61557-12
Measurement of energy	
Accuracy of active energy	Class 0.5 IEC 61557-12
Accuracy of reactive energy	Class 1 IEC 61557-12
Mechanical characteristics	
Casing type	DIN rail or back plate mounting
Casing protection index	IP20 / IK08
Weight	63 g
Module power consumption	0.35 VA

Communication specifications

Digiware BUS	
Function	Connection between DIRIS Digiware S, U, I modules and system interfaces
Cable type	Specific Socomec cable with RJ45 connections
USB	
Protocol	MODBUS RTU on USB
Function	Configuration of DIRIS Digiware modules
Location	On each DIRIS Digiware module
Connection	Type B micro USB connector

Environmental specifications

Ambient operating temperature	-10 ... +55°C
Storage temperature	-25 ... +70°C
Operating humidity	40°C / 95% RH
Operating altitude	< 2000 m

References

DIRIS Digiware S		Reference
S-130	Metering - 3 integrated current inputs	4829 0160
S-135	Analysis - 3 integrated current inputs	4829 0161
Accessories		Reference
DIN rail and back plate mounting clip (x10)		4829 0195
Temporary MCB insert (x10)		4829 0196

Digiware connection cables		Reference
RJ45 cables for Digiware Bus	Length 0.06 m ⁽¹⁾	4829 0189
	Length 0.10 m	4829 0181
	Length 0.20 m	4829 0188
	Length 0.50 m	4829 0182
	Length 1 m	4829 0183
	Length 2 m	4829 0184
	Length 3 m	4829 0190
	Length 5 m	4829 0186
	Length 10 m	4829 0187
	50 m reel + 100 connectors	
Termination for Digiware Bus (supplied with interfaces C and D)		4829 0180
USB configuration cable		4829 0050

(1) The RJ45 6 cm cables can be used on 3-pole or 4-pole protective devices.

Expert Services

Require integration onto your network?

No problem for our "Expert Services" team. They will fully integrate all your SOCOMEC devices, **audit** your system, **commission** selected equipment and **train** your staff on its use.

For further information, please contact your nearest SOCOMEC branch.

DIRIS Digiware *lac*

Current acquisition modules



DIRIS Digiware I-3x



DIRIS Digiware I-4x



DIRIS Digiware I-6x



Configuration
with Easy Config System.

Function

DIRIS Digiware *lac* modules measure consumption and monitor the system at the closest point to the loads. The flexibility of these modules allows you to allocate the loads to be measured or monitored through independent current inputs.

For example:

- 1 three-phase load,
- 3 single-phase loads.

The RJ45 and RJ12 connections allow you to connect modules very quickly and to automatically configure connected current sensors:

- communication address,
- load type,
- sensor type and ratio,
- automatic rating and verification of current travel direction.

Wiring errors are also prevented and installation is simplified.

Advantages

- RJ45 and RJ12 rapid connection.
- Available with 3, 4 or 6 inputs.
- Single-output or multi-output for maximum optimisation of the number of products.
- Compact format: 1 or 2 modules sized for integration at the closest point to the loads.
- A complete, dedicated solution:
 - metering,
 - monitoring,
 - quality analysis.
- Compliant with standard IEC 61557-12, guaranteeing the quality and accuracy of the system:
 - class 0.5 for the 2 - 120% rated current global measurement chain I_n (with TE/ iTR/TF current sensors).

The solution for

- > Industry
- > Building
- > Infrastructure
- > Data center



Strong points

- > Multi-circuit
- > Plug and Play
- > Compact
- > High-precision measurement chain

Integrated technologies



PreciSense



AutoCorrect



VirtualMonitor

For more information see our website
www.socomec.com

Conformity to standards

- > IEC 61557-12



- > ISO 14025









- > UL



Create your project

- > Find the best DIRIS Digiware configuration:
www.meter-selector.com



Application	Current measurement modules						
	Metering		Analysis	Monitoring	Analysis	Metering	
							
DIRIS Digiware lac	I-30	I-31	I-35	I-43	I-45	I-60	I-61
Number of current inputs	3	3	3	4	4	6	6
Metering							
± kWh, ± kvarh, kVAh	•	•	•	•	•	•	•
Load curves		•	•		•		•
Multi-tariff		•	•		•		•
Multi-measurement							
I1, I2, I3, In, ΣP, ΣQ, ΣS, ΣPF	•	•	•	•	•	•	•
P, Q, S, PF per phase		•	•	•	•		•
Predictive power			•		•		
Current unbalance (Inba, Idir, linv, Ihom, Inb)			•		•		
Phi, cos Phi, tan Phi			•		•		
Quality							
THDi1, THDi2, THDi3, THDin			•	•	•		
Individual harmonics I (up to 63rd)			•		•		
Overcurrents			•		•		
Alarms							
On threshold		○	•		•		○
Inputs/outputs				2/2	2/2		
History of average values							
45 days (max)			•		•		
Format							
Width/number of modules	18 mm / 1	18 mm / 1	18 mm / 1	27 mm / 1.5	27 mm / 1.5	36 mm / 2	36 mm / 2

○ : only for total power (P,Q,S).

Accessories

Digiware plug-in connector

With the Digiware plug-in connector you can disconnect a DIRIS Digiware module from the Bus while ensuring the DIRIS Digiware system continues to run downstream.

This accessory is particularly useful in applications with retractable drawers or critical applications such as in data centres.



dfis-o_025.eps

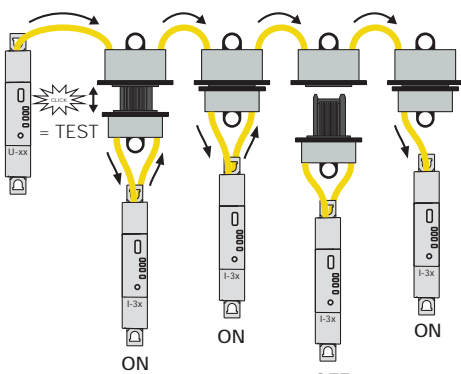

dfis-o_026.ai

Dimensions (mm)

DIRIS Digiware I-3xac / I-6xac

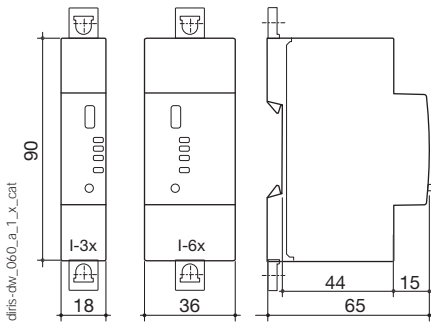

DIRIS Digiware I-4xac

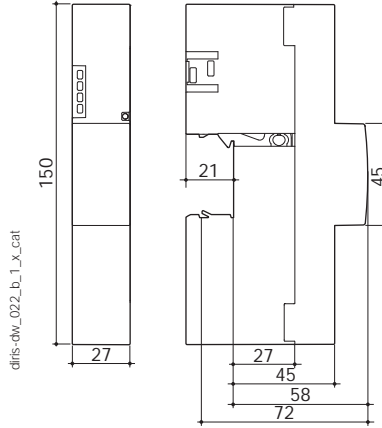

Connections

Associated current sensors

Various types of current sensors are connected to the DIRIS Digiware: closed (TE), split core (TR/ITR) or flexible (TF). This range of sensors can be adapted to all types of new or existing installations. A rapid RJ12 connection makes wiring easy and reliable and prevents wiring errors. The DIRIS Digiware system automatically recognises the sensor size and type. This guarantees the overall accuracy of the DIRIS Digiware + current sensor measurement chain.

For more information see "TE, TR and TF sensors" pages.

Network and connection examples

I-3x

Three-phase

3P - 3CT (1 three-phase load)

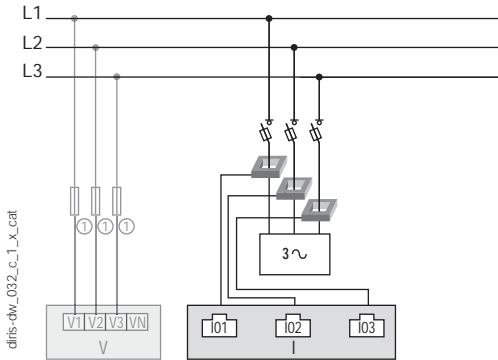

Three-phase

3P - 1CT (3 balanced, three-phase loads)

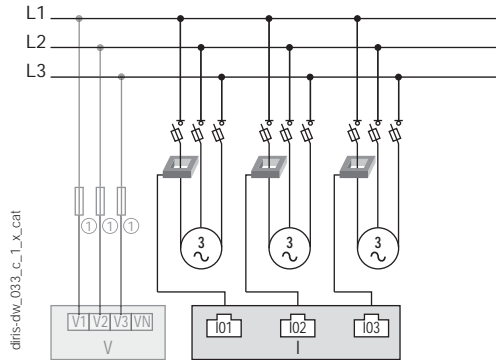

I-4x

Three phase + neutral

3P+N - 4CT (1 three-phase load + Neutral measured)

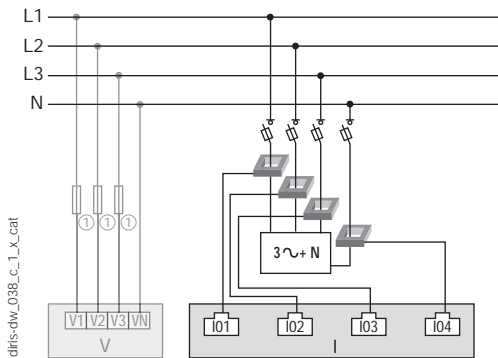

1. 0.5 A gG / 0.5 A class CC fuses.

Single-phase

1P+N-1CT (4 single-phase loads)

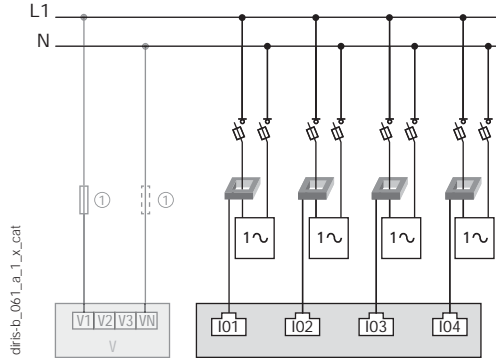

CT: Current sensor 3~ Load

Specifications

Measuring characteristics

Current measurement - DIRIS Digiware lac	
Number of current inputs	I-3x: 3 / I-45: 4 / I-6x: 6
Associated current sensors	Solid TE, split-core TR / iTR, flexible TF current sensors
Accuracy of current measurement	0.2 DIRIS Digiware class only Class 0.5 with TE, iTR or TF sensors Class 1 with TR sensors
Connection	Specific Socomec cable with RJ12 connectors

Inputs - DIRIS Digiware I-45ac	
Number of inputs	2
Type / Power supply	Non-insulated input, internal polarisation 12 VDC max, 1mA
Input functions	Logic status, pulse meter, multi-tariff
Connection	Removable screw terminal block, stranded or solid 0.14-1.5 mm ² cable

Outputs - DIRIS Digiware I-45ac	
Number of outputs	2
Relay type	230 VAC ±15 % - 1 A 30 VDC - 3 A
Function	Configurable alarm (current, power, etc.) when threshold is exceeded or remote controlled status
Connection	Removable screw terminal block, stranded or solid 0.2-2.5 mm ² cable

Communication specifications

USB	
Protocol	Modbus RTU on USB
Function	Configuration of DIRIS Digiware U and I modules
Location	On each DIRIS Digiware U and I measurement module
Connection	Type B micro USB connector

References

DIRIS Digiware	Reference
I-30 Metering - 3 current inputs	4829 0110
I-31 Metering + load curve - 3 current inputs	4829 0111
I-35 Analysis - 3 current inputs	4829 0130
I-43 Monitoring - 2 inputs/ 2 outputs - 4 current inputs	4829 0129
I-45 Analysis - 2 inputs/ 2 outputs - 4 current inputs	4829 0131
I-60 Metering - 6 current inputs	4829 0112
I-61 Metering + load curve - 6 current inputs	4829 0113

Accessories	Reference
Digiware x 5 plug-in connector	4829 0605

Digiware connection cables	Reference	
RJ45 cables for Digiware Bus	Length 0.06 m	4829 0189
	Length 0.10 m	4829 0181
	Length 0.20 m	4829 0188
	Length 0.50 m	4829 0182
	Length 1 m	4829 0183
	Length 2 m	4829 0184
	Length 3 m	4829 0190
	Length 5 m	4829 0186
	Length 10 m	4829 0187
Reel 50 m + 100 connectors	4829 0185	
Digiware bus terminating resistor (supplied with C and D devices)	4829 0180	
USB configuration cable	4829 0050	

(1) DIRIS D-30 display characteristics see "DIRIS B" pages.

Expert Services

Require integration onto your network?

No problem for our "Expert Services" team. They will fully integrate all your SOCOMEC devices, **audit** your system, **commission** selected equipment and **train** your staff on its use.

For further information, please contact your nearest SOCOMEC branch.

TE sensors

Solid current sensors

used with DIRIS Digiware, DIRIS A-40 and DIRIS B



TE solid sensors

The solution for

- > Industry
- > Building
- > Infrastructure
- > Data center



Strong points

- > Plug & Play
- > Accuracy as per standard IEC 61557-12
- > Installation

Conformity to standards

- > IEC 61557-12



- > ISO 14025



- > UL



Create your project

- > Find the best DIRIS Digiware configuration:

www.meter-selector.com



Function

TE smart **current sensors** measure the load currents of an electrical system and send the data to meters and measurement hubs via an RJ12 plug-and-play output. Thanks to a wide measurement range, TE current sensors cover the full current range of 5 to 2000 A, with 7 references. TE solid current sensors can be connected to DIRIS Digiware, DIRIS A-40 and DIRIS B via a rapid RJ12 connection.

Numerous accessories are available to aid the installation of sensors in any type of cabinet.

Advantages

Plug & Play

- A rapid RJ12 connection makes wiring easy and reliable and prevents wiring errors. This also allows automatic detection of the sensor type and size/transformation ratio.
- The sensors can be installed in both directions.

Accuracy as per standard IEC 61557-12

- Class 0.5 for the global measuring chain (measurement hub + TE current sensors) from 2 to 120% of the nominal current I_n .

Installation

- The TE solid sensor range is specially designed for new installations, and has the same pitch as the most common protective devices.

Mounting

Linear assembly with the protective devices
TE-25 / TE-35 / TE-45 / TE-55 / TE-90

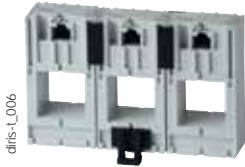

DIN rail mounted



TE-90 clamps



Staggered assembly
TE-18 / TE-35 / TE-45 / TE-55



Back-plate mounting

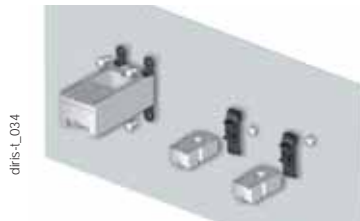

Cable mounting



Bar mounting

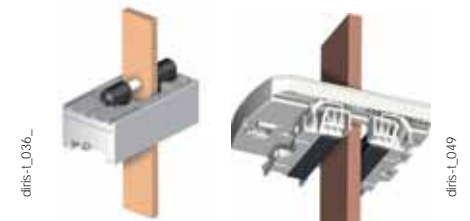

Connections

TE / TR / iTR / TF current sensors







TE sensors

Solid current sensors

used with DIRIS Digiware, DIRIS A-40 and DIRIS B

Mounting accessories

Mounting accessories delivered with TE sensors:

Switch mounting	TE-18	TE-25	TE-35 TE-45 TE-55	TE-90
 DIN rail and back-plate	1 pc			2 pcs
 DIN rail		2 pcs	2 pcs	
 Back-plate		4 pcs	4 pcs	6 pcs
 Busbar			2 pcs	

Compatible accessories

Adapter for CT with 5A secondary

- With this adapter you can use a current transformer with a 1 A or 5 A output on DIRIS Digiware I, DIRIS B and DIRIS A-40. For use with 5 A CTs (measurement up to 10 000 A) or 1 A CTs (measurement up to 2000 A). The dimensions are the same as the TE-18.



Coupling link

- Associated with the TE range, this accessory is for inter-connecting the sensors when linear or staggered mounted.



Sealable cover

- Using a sealable cover guarantees the immunity of the sensor connection on TE/TR/iTR/ TF current sensors.



Dimensions (mm)

TE - Solid current sensors

TE-18

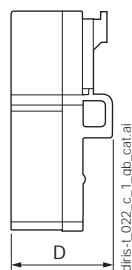
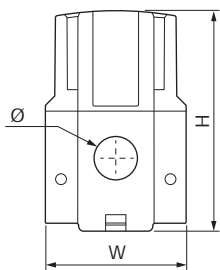

TE-25 / TE-35 / TE-45 / TE-55

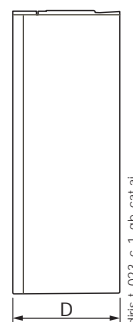
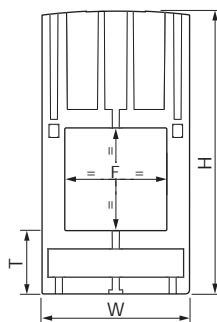

TE-90

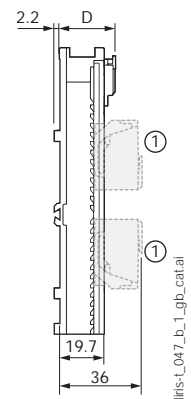
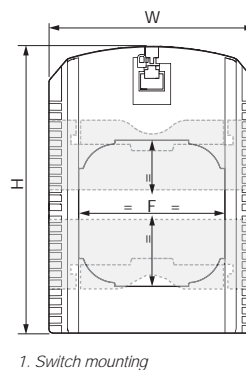

Model	Nominal current range (A)	Real range covered (A)	Pitch (mm)	H x W x D (mm)	F (mm)	T (mm)
TE-18	5 ... 20 / 25 ... 63	0.1 ... 24 / 0.5 ... 75	18	45 x 28 x 20	8.6	-
TE-25	40 ... 160	0.8 ... 192	25	65 x 25 x 32.5	13.5 x 13.5	17.5
TE-35	63 ... 250	1.26 ... 300	35	71 x 35 x 32.5	21 x 21	17.5
TE-45	160 ... 630	3.2 ... 756	45	86 x 45 x 32.5	31 x 31	19.5
TE-55	400 ... 1000	8 ... 1200	55	100 x 55 x 32.5	41 x 41	21.5
TE-90	600 ... 2000	12 ... 2400	90	126 x 90 x 24.6	64 x 64	-

Specifications

TE - Solid current sensors							
Model	TE-18	TE-18	TE-25	TE-35	TE-45	TE-55	TE-90
Nominal current range I_n (A)	5 ... 20	25 ... 63	40 ... 160	63 ... 250	160 ... 630	400 ... 1000	600 ... 2000
Real range covered (A)	0.1 ... 24	0.5 ... 75	0.8 ... 192	1.26 ... 300	3.2 ... 756	8 ... 1200	12 ... 2400
Max. current (A)	24	75.6	192	300	756	1200	2400
Weight (g)	24	24	69	89	140	187	163
Max. voltage (phase/neutral)	300 V					600 V	
Rated withstand voltage	3 kV						
Frequency	50/60 Hz						
Intermittent overload	10 x I_n over 1 sec						
Measurement category	CAT III						
Protection degree	IP30 / IK06						
Operating temperature	-10 ... +70°C						
Storage temperature	-25 ... +85°C						
Relative humidity	95% RH non-condensing						
Altitude	< 2000 m						
Connection	Socomec RJ12 cable						

References

Model	Nominal current range (A)	Real range covered (A)	Pitch (mm)	Reference
TE-18	5 ... 20	0.1 ... 24	18	4829 0500
TE-18	25 ... 63	0.5 ... 75	18	4829 0501
TE-25	40 ... 160	0.8 ... 192	25	4829 0502
TE-35	63 ... 250	1.26 ... 300	35	4829 0503
TE-45	160 ... 630	3.2 ... 756	45	4829 0504
TE-55	400 ... 1000	8 ... 1200	55	4829 0505
TE-90	600 ... 2000	12 ... 2400	90	4829 0506

Accessories	Reference
Coupling link (20 linear assembly parts and 10 for staggered assembly)	4829 0598
5 A CT adapter (max primary current 2000 A /1 A or 10 000 A /5 A)	4829 0599
Sealable caps (20 pieces)	4829 0600

RJ12 connection cables	Cable length (m)									
	0.1	0.2	0.3	0.5	1	2	3	5	10	50 m reel + 100 connectors
Number of cables	Reference	Reference	Reference	Reference	Reference	Reference	Reference	Reference	Reference	Reference
1	-	-	-	-	-	-	-	4829 0602	4829 0603	4829 0601
3	4829 0580	4829 0581	4829 0582	4829 0595	4829 0583	4829 0584	4829 0606	-	-	-
4	-	-	-	4829 0596	4829 0588	4829 0589	-	-	-	-
6	4829 0590	4829 0591	4829 0592	4829 0597	4829 0593	4829 0594	-	-	-	-

TR/iTR sensors

Split-core AC current sensors

used with DIRIS Digiware, DIRIS A-40 and DIRIS B



TR Split-core current sensors

The solution for

- > Retrofit applications
- > Industry
- > Building
- > Infrastructure
- > Data centers



Strong points

- > Smart sensors
- > PreciSense technology: Accurate
- > Easy installation and configuration

Integrated technologies⁽¹⁾



⁽¹⁾ AutoCorrect and VirtualMonitor are only available with iTR sensors.

For more information see our website www.socomec.com

Compliance with standards

- > IEC 61557-12



- > ISO 14025



- > UL



Create your project

- > Find the best DIRIS Digiware configuration: www.meter-selector.com

METER SELECTOR
DIGITAL TOOL AVAILABLE

Function

The **split-core current sensors** in the TR and iTR ranges enable the current of an electrical installation to be measured. Used with power monitoring device DIRIS Digiware, DIRIS A-40, DIRIS B, they make it possible to perform measurements between 25 and 600 A, with guaranteed accuracy. The RJ12 connection provides quick connections, and the integrated intelligence prevents any configuration errors.

The sensors in the iTR range revolutionise the world of measurement and provide access to VirtualMonitor status monitoring technologies and to AutoCorrect automatic configuration.

Advantages of the TR and iTR ranges

Smart sensors

- Sensors with an extended operational range.
- Automatic detection of rating.
- Secured disconnection of load.
- Quick connection via RJ12 and identification of cable by colour code.

Accurate

- Measurement precision guaranteed in acc. with standard IEC 61557-12 : class 0.5 (iTR) or 1 (TR) for the global measuring chain from 2 to 120% of I_n .

Unique advantages of the iTR range

VirtualMonitor technology

VirtualMonitor provides monitoring of protective devices:

- Across the entire electrical installation.
- Remotely and in real-time.
- Without additional hardware or wiring (no auxiliary contacts needed).

AutoCorrect technology

AutoCorrect guarantees that your measurement system is working correctly:

- Automatic wiring control (current voltage phase association).
- Correction of errors.
- Feature available off load.

Installation

Cable mounting



Dimensions (mm)

TR-10 / TR-14 / TR-21 / TR-32

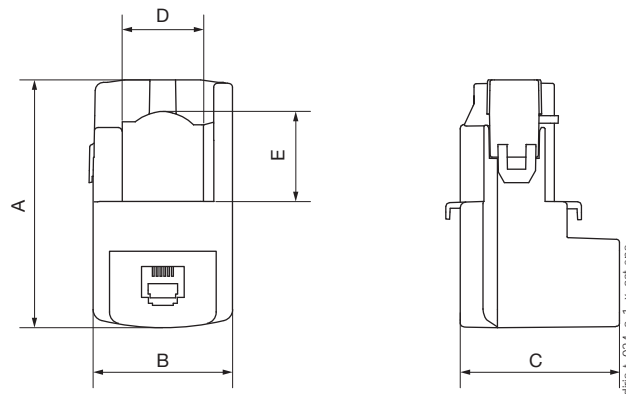

Model	Nominal current range (A)	Real range covered (A)	A (mm)	B (mm)	C (mm)	D (mm)	E (mm)	Ø (mm)
TR/iTR-10	25 ... 63	0.5 ... 75.6	44	26	28	-	-	10
TR/iTR-14	40 ... 160	0.8 ... 192	67	29	28	14	15	14
TR/iTR-21	63 ... 250	1.26 ... 300	65	37	43	21	23	21
TR/iTR-32	160 ... 600	3.2 ... 720	86	53	47	32	33	32

Technical characteristics

Model	TR-10	iTR-10	TR-14	iTR-14	TR-21	iTR-21	TR-32	iTR-32
Nominal current range I_n (A)	25 ... 63		40 ... 160		63 ... 250		160 ... 600	
Real range covered (A)	0.5 ... 75.6		0.8 ... 192		1.26 ... 300		3.2 ... 720	
Max. current (A)	75.6		192		300		720	
Weight (g)	74		117		211		311	
Max. voltage (phase/neutral)	300 V							
Rated withstand voltage	3 kV							
Frequency	50/60 Hz							
Intermittent overload	10 x I_n for 1 s							
Measurement category	CAT III							
Global class used with Diris Digiware/A-40/B-10/B-30	Class 1	Class 0.5	Class 1	Class 0.5	Class 1	Class 0.5	Class 1	Class 0.5
Protection degree	IP20 / IK07							
Operating temperature range	-10 to +70°C						-10°...+55°C	
Storage temperature range	-25 to +85°C							
Relative humidity	95% RH non-condensing							
Altitude	< 2000 m							
Connection	Socomec RJ12 cable							

References

Model	Nominal current range (A)	Real range covered (A)	Ø (mm)	Reference
TR-10	25 ... 63	0.5 ... 75	10	4829 0555
TR-14	40 ... 160	0.8 ... 192	14	4829 0556
TR-21	63 ... 250	1.26 ... 300	21	4829 0557
TR-32	160 ... 600	3.2 ... 720	32	4829 0558

Model	Nominal current range (A)	Real range covered (A)	Ø (mm)	Reference
iTR-10	25 ... 63	0.5 ... 75	10	4829 0655
iTR-14	40 ... 160	0.8 ... 192	14	4829 0656
iTR-21	63 ... 250	1.26 ... 300	21	4829 0657
iTR-32	160 ... 600	3.2 ... 720	32	4829 0658

RJ12 connection cables	Cable length (m)									
	0.1	0.2	0.3	0.5	1	2	3	5	10	50 m reel + 100 connectors
Number of cables	Reference	Reference	Reference	Reference	Reference	Reference	Reference	Reference	Reference	Reference
1	-	-	-	-	-	-	-	4829 0602	4829 0603	4829 0601
3	4829 0580	4829 0581	4829 0582	4829 0595	4829 0583	4829 0584	4829 0606	-	-	-
4	-	-	-	4829 0596	4829 0588	4829 0589	-	-	-	-
6	4829 0590	4829 0591	4829 0592	4829 0597	4829 0593	4829 0594	-	-	-	-

TF sensors

Flexible TF current sensors

used with DIRIS Digiware, DIRIS A-40 and DIRIS B



TF Flexible current sensors

diris-L_077.eps

The solution for

- > Industry
- > Building
- > Infrastructure
- > Data centers



Strong points

- > Plug & Play
- > Accuracy according to IEC 61557-12
- > Safe locking mechanism
- > Installation
- > Simplified installation

Integrated technologies



PreciSense

For more information see our website www.socomec.com

Compliance with standards

- > IEC 61557-12



- > ISO 14025



- > UL



Create your project

- > Find the best DIRIS Digiware configuration: www.meter-selector.com



Function

TF flexible current sensors measure the load currents of an electrical circuit and send the data to meters and Power Monitoring Devices or current modules via an RJ12 plug-and-play connection. Thanks to a wide measurement range, TF current sensors cover a wide current range from 100 to 6000 A, with only 7 references. TF flexible current sensors can be used with DIRIS Digiware I modules, DIRIS A-40 and DIRIS B.

Advantages

Plug & Play

- A rapid RJ12 connection makes wiring easy and reliable and prevents wiring errors. This also allows automatic detection of the sensor type and rating.
- The sensors can be installed in both directions.

Accuracy according to IEC 61557-12

- Class 0.5 for the global measuring chain (PMD + TF current sensors) from 2 to 120% of the nominal current I_n .
- Accuracy is guaranteed regardless of the position of the conductor in the loop.

Safe locking mechanism⁽¹⁾

- The locking system prevents the loop from opening, guaranteeing continuous functioning and accuracy even under harsh conditions.

Installation

- The TF flexible sensor range is specially designed for existing installations with strict integration constraints or with high-intensity currents.

Simplified installation

- The Rogowski integrator is directly integrated to the RJ12⁽¹⁾ cable enabling a quick and compact integration (no DIN rail assembly required) inside electrical panels.
- The integrator is self supplied by the PMD through the RJ12 cable and does not need any external power supply.

⁽¹⁾ Except for TF-55.

Installation

Cable mounting



diris-L_079.psd

Bar mounting

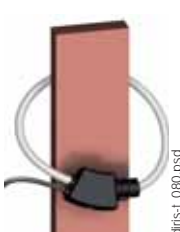

diris-L_080.psd

Dimensions (mm)

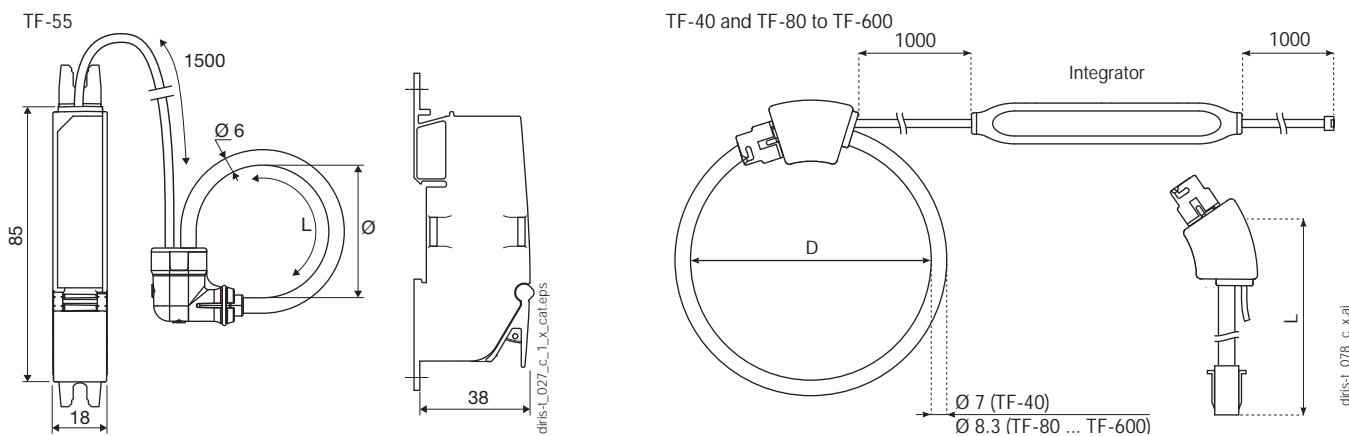

Model	Nominal current range (A)	Real range covered (A)	D = Ø loop (mm)	L = Loop length (mm)
TF-40	100 ... 400	2 ... 480	40	126
TF-55	150 ... 600	3 ... 720	55	173
TF-80	150 ... 600	3 ... 720	80	251
TF-120	400 ... 2000	8 ... 2400	120	377
TF-200	600 ... 4000	12 ... 4800	200	628
TF-300	1600 ... 6000	32 ... 7200	300	942
TF-600	1600 ... 6000	32 ... 7200	600	1885

Integrator dimensions: 128 x 19 x 15 mm

Technical characteristics

Model	TF-40	TF-55	TF-80	TF-120	TF-200	TF-300	TF-600
Nominal current range I _n (A)	100 ... 400	150 ... 600	150 ... 600	400 ... 2000	600 ... 4000	1600 ... 6000	1600 ... 6000
Real range covered (A)	2 ... 480	3 ... 720	3 ... 720	8 ... 2400	12 ... 4800	32 ... 7200	32 ... 7200
Weight (g)	114	114	130	142	164	193	274
Max. voltage (phase/neutral)	600 V						
Rated withstand voltage	3.6 kV						
Accuracy class	0.5 in association with DIRIS Digiware I, DIRIS A-40, DIRIS B based on IEC 61557-12						
Frequency	50 / 60 Hz						
Intermittent overload	10 x I _n for 1 s						
Measurement category	CAT III						
Protection degree	IP30 / IK07						
Operating temperature	-10 to +70°C						
Storage temperature	-25 to +85°C						
Relative humidity	95% RH non-condensing						
Altitude	< 2000 m						
Connection	Socomec cable or equivalent RJ12 straight, twisted pair, unshielded, 600 V, -10 ... +70 °C						

References

Model	Nominal current range (A)	Real range covered (A)	D = Ø loop (mm)	L = Loop length (mm)	Reference
TF-40	100 ... 400	2 ... 480	40	126	4829 0573
TF-55	150 ... 600	3 ... 720	55	173	4829 0570
TF-80	150 ... 600	3 ... 720	80	251	4829 0574
TF-120	400 ... 2000	8 ... 2400	120	377	4829 0575
TF-200	600 ... 4000	12 ... 4800	200	628	4829 0576
TF-300	1600 ... 6000	32 ... 7200	300	942	4829 0577
TF-600	1600 ... 6000	32 ... 7200	600	1885	4829 0578

Accessories

Accessories	Reference
Female/female connector for extension of the RJ12 connection between PMD and TF sensor	4829 0670

RJ12 connection cables	Cable length (m)									
	0.1	0.2	0.3	0.5	1	2	3	5	10	50 m reel + 100 connectors
Number of cables	Reference	Reference	Reference	Reference	Reference	Reference	Reference	Reference	Reference	Reference
1	-	-	-	-	-	-	-	4829 0602	4829 0603	4829 0601
3	4829 0580	4829 0581	4829 0582	4829 0595	4829 0583	4829 0584	4829 0606	-	-	-
4	-	-	-	4829 0596	4829 0588	4829 0589	-	-	-	-
6	4829 0590	4829 0591	4829 0592	4829 0597	4829 0593	4829 0594	-	-	-	-

DIRIS Digiware R-60

Residual Current Monitoring module



diris-dw_173_front

DIRIS Digiware R-60



Configuration with
Easy Config System software.

Function

DIRIS Digiware R-60 modules combine residual current monitoring (RCM) with power metering and monitoring functions, for any combination of 1-phase, 2-phase or 3-phase circuits used in TN-S and TT earthing systems.

With six RJ12 channels, they can be connected to a mix of Δ IC residual CTs and TE/TR/ITR/TF current sensors via RJ12 cables enabling quick connection and avoiding wiring errors.

Advantages

2 in 1

One DIRIS Digiware R-60 module can be connected to residual CTs and traditional TE/TR/ITR/TF current sensors to pool residual current and power monitoring.

Multi-circuit

One DIRIS Digiware R-60 module can monitor the residual current on up to 6 circuits.

The Digiware modular concept allows several R-60 modules to be added within a single system, making it easy to implement RCM for a large number of outgoing circuits instead of the main incomer only.

Plug & Play solution

The Digiware concept and the RJ45 bus allow:

- easy connection of R-60 modules to an existing DIRIS Digiware system,
- optimal scalability by adding additional modules when needed.

The connection to current sensors is quick and error-free thanks to colour coded RJ12 cables.

Smart alarming

DIRIS Digiware R-60 provides the most advanced RCM alarm features for preventive notifications:

- before the residual current device (RCD) trips,
- before leakage currents become hazardous for people and assets,
- if the RCD is defective.

The combination with Virtual Monitor technology specifies if the RCD has tripped on an overload or a high residual current.

Patented innovation

Thanks to an automatic learning sequence, launched for a chosen duration representative of the normal operation of the electrical installation, 6 dynamic residual current (I_{Δ}) thresholds are automatically set. This facilitates the determination of the maximum residual current not to be exceeded for each outgoing circuit.

The solution for

- > Industries
- > Data centres



Strong points

- > 2 in 1
- > Multi-circuit
- > Plug & play solution
- > Smart alarming
- > Patented innovation

Compliance with standards

- > IEC 62020
- > IEC 61557-12



- > ISO 14025



Create your project

- > Find the best DIRIS Digiware configuration:
www.meter-selector.com



Applications

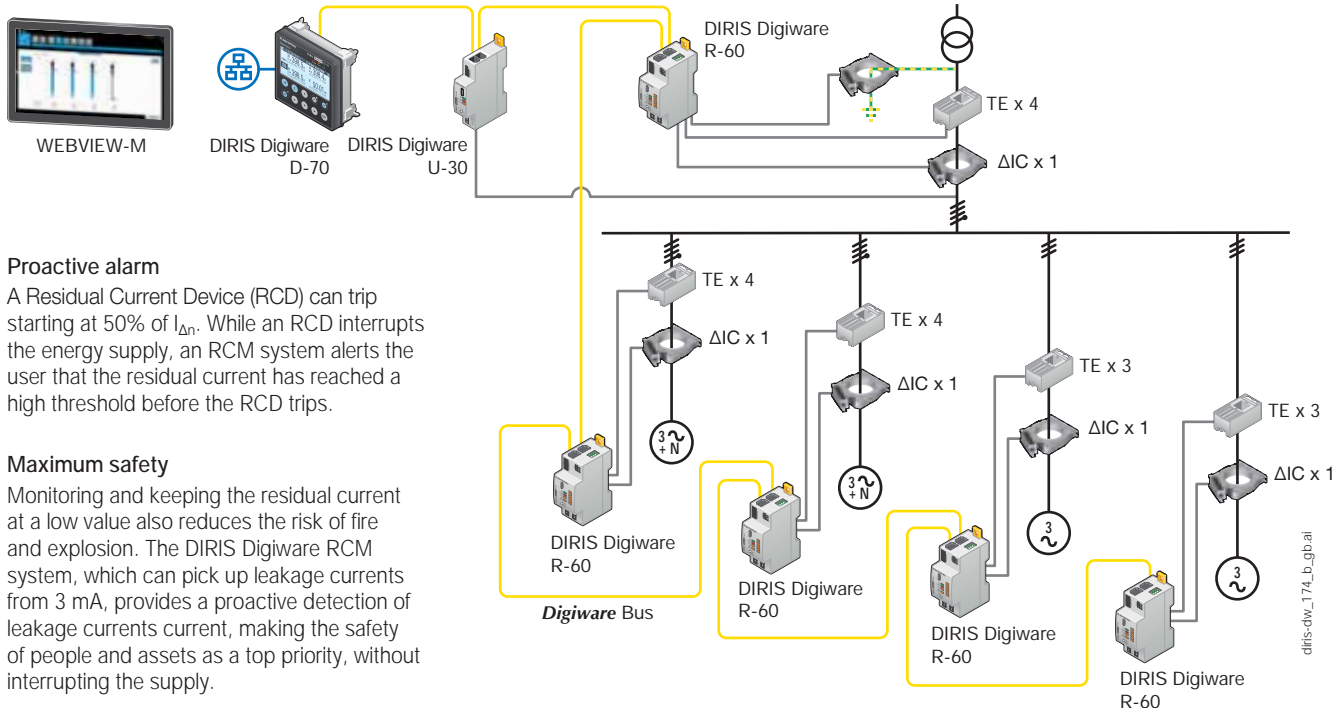

Proactive alarm

A Residual Current Device (RCD) can trip starting at 50% of $I_{\Delta n}$. While an RCD interrupts the energy supply, an RCM system alerts the user that the residual current has reached a high threshold before the RCD trips.

Maximum safety

Monitoring and keeping the residual current at a low value also reduces the risk of fire and explosion. The DIRIS Digiware RCM system, which can pick up leakage currents from 3 mA, provides a proactive detection of leakage currents current, making the safety of people and assets as a top priority, without interrupting the supply.

Protective earthing (PE) conductor

Adding a residual CT on the upstream PE conductor is essential to ensure the proper connection to earth.

It is also the easiest and cheapest way to measure the upstream residual current reliably.

Compliance with installation standards

Many local electrical codes require an insulation resistance measurement as part of the Periodic Inspection and Testing. This operation is costly as it must be done on all outgoing circuits and intrusive as the main protective device must be opened.

According to IEC 60364-6 installation standards and many national transpositions, periodic insulation resistance testing is not necessary if permanently monitored by an RCM system such as the DIRIS Digiware RCM system.

Measurements

DIRIS Digiware R-60	
Residual Current Monitoring	
I_{Δ}	•
I_{PE}	•
Metering	
+/- kWh, +/- kvarh, kVAh	•
Multi-tariff (max 8)	•
Load curves	•
Multi-measurement	
I1, I2, I3, In, ΣP, ΣQ, ΣS, ΣPF	•
P, Q, S, PF per phase	•
Alarms	
Dynamic I_{Δ} and I_{PE} thresholds	•
Overloaded neutral conductor	•
Protective device (opening, Trip, defective RCD)	•
I_{Δ} and I_{PE} comparisons	•
Trends	
I_{Δ}	•
I_{PE}	•
Load curves	•

Front face



1. USB port for configuration.
2. ON LED. Lights when the device is active.
3. ALARM LED for system alarms (CT disconnected, etc.)
4. COM LED. Flashes when the communication bus is active.
5. RCM FAULT. Lights if there is an RCM alarm on any of the channel 1 through 6.
6. TEST / RESET button. Starts the auto test (long press) and resets alarms (short press). Used during auto-discovery process for the resolution of address conflicts.
7. Individual LED alarm signals for each channel 1 to 6.

DIRIS Digiware R-60

Residual Current Monitoring module

Connections

Associated sensors

Various types of residual CTs and current sensors can be connected to the DIRIS Digiware R-60 module: Δ IC solid-core, Δ IP-R split-core residual CTs, and solid-core TE, split-core TR/iTR, flexible TF current sensors. This range of sensors can be adapted to all types of new or existing installations. A rapid RJ12 connection makes wiring easy and reliable and prevents wiring errors.

For more information: refer to the residual CTs and current sensors catalogue pages

TE solid current sensors

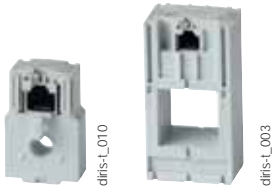

Δ IC solid-core residual CTs



TR/iTR split-core current sensors



TF Flexible current sensors



Δ IP-R split-core residual CTs



Connection examples

RCM (I_{Δ}) – 3 x 3-Ph load

Load current monitoring – L1, L2, L3, upstream

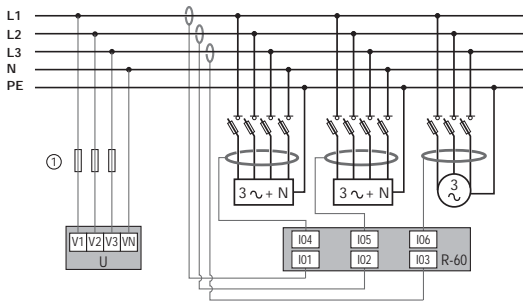

diris-dw_176_b_1_x_catal

RCM ($I_{\Delta} + I_{PE}$) – 1 x 3-Ph load

Load current monitoring – 1 x 3-Ph load (L1, L2, L3, N)

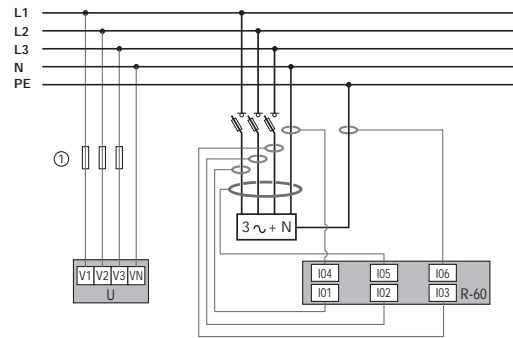

diris-dw_179_a_1_x_catal

RCM (I_{Δ}) – 3 x 3-Ph load

Load current monitoring – 3 x 3-Ph balanced loads

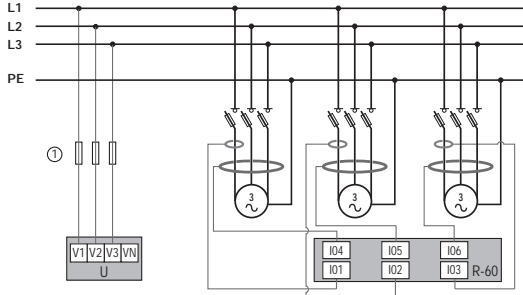

diris-dw_180_a_1_x_catal

RCM (I_{Δ}) – 3 x 1-Ph load

Load current monitoring – 3 x 1-Ph loads

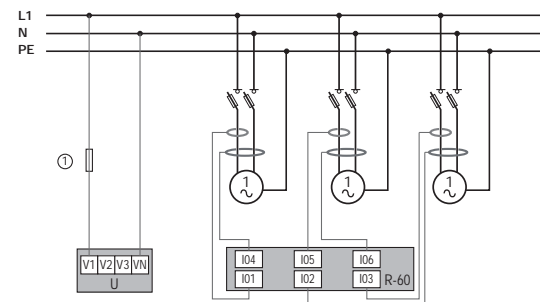

diris-dw_181_a_1_x_catal



Dimensions (mm)

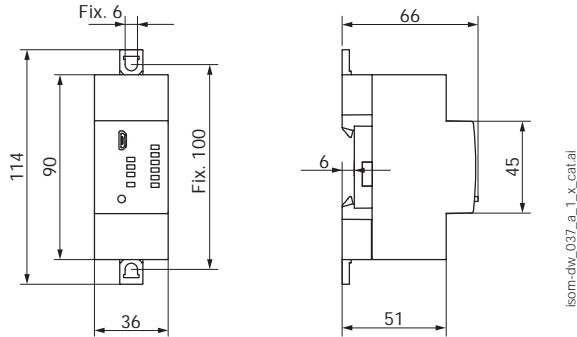

Terminals and wiring

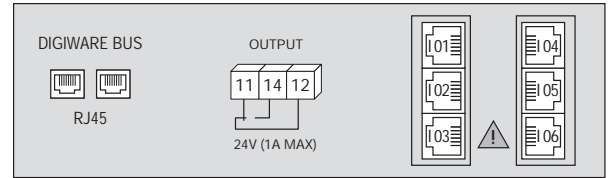

DIGIWARE BUS: RJ45 bus to connect to other Digiware modules

11 - 12 - 14: alarm relay output
I01 - I02 - I03 - I04 - I05 - I06: RJ12 connection of residual CTs (via the T-10 adaptor) and current sensors

isom-dw_038_b_1_x_catal

Technical characteristics

Measurement characteristics

RCM type	Type A according to IEC 62020
Number of RJ12 channels	6
Residual CTs connection	RJ12 cables via Digiware T-10 adaptor
Current sensors connection	RJ12 cables
Current measurement accuracy	Class 0.5 according to IEC 61557-12
Active energy accuracy	Class 0.5 according to IEC 61557-12
Reactive energy accuracy	Class 1 according to IEC 61557-12

Digital output characteristics

Number of contacts	1
Contact type	Changeover switch
Nominal voltage	24 VAC / 24 VDC
Max current	1 A
Default mode	Normally open

Mechanical characteristics

Mounting type	DIN rail or back plate
Casing protection index	IP20
Weight	103 g

Electrical characteristics

Auxiliary power supply	24 VDC with Digiware bus
R-60 consumption	0.5 W

Communication characteristics

Digiware bus	
Function	Connection between Digiware modules
Cable type	Specific Socomec RJ45 cable
USB	
Protocol	Modbus RTU on USB
Function	Configuration of DIRIS Digiware modules
Cable type	Type B micro USB connector

Environmental characteristics

Operating temperature	-10 ... +55°C
Storage temperature	-25 ... +70°C
Operating humidity	55°C / 97% RH
Operating altitude	< 2000 m

References

Module	Reference
DIRIS Digiware R-60	4829 0114
Accessories	Reference
DIRIS Digiware T-10 RJ12 adaptor	4829 0620

RJ12 connection cables	Cable length (m)									
	0.1	0.2	0.3	0.5	1	2	3	5	10	50 m reel + 100 connectors
Number of cables	Reference	Reference	Reference	Reference	Reference	Reference	Reference	Reference	Reference	Reference
1	-	-	-	-	-	-	-	4829 0602	4829 0603	4829 0601
3	4829 0580	4829 0581	4829 0582	4829 0595	4829 0583	4829 0584	4829 0606	-	-	-
4	-	-	-	4829 0596	4829 0588	4829 0589	-	-	-	-
6	4829 0590	4829 0591	4829 0592	4829 0597	4829 0593	4829 0594	-	-	-	-

Expert Services

Require integration onto your network?

No problem for our "Expert Services" team. They will fully integrate all your SOCOMEC devices, **audit** your system, **commission** selected equipment and **train** your staff on its use.

For further information, please contact your nearest SOCOMEC branch.

DIRIS Digiware IO

Digital and analogue input/output modules



DIRIS Digiware IO-10
4 digital inputs/2 digital outputs

DIRIS Digiware IO-20
2 analogue inputs



Configuration
with Easy Config System.

Function

DIRIS Digiware IO modules enrich the measurement system with multiple features:

- DIRIS Digiware IO-10 modules have 4 digital inputs and 2 digital outputs. The 4 digital inputs can be used to monitor the status of third-party devices (position of protective devices, trip counter) or to collect pulses from multi-fluid meters. The 2 digital outputs allow the remote control of third-party equipment signal. Alarms can be configured and assigned to the digital outputs.

- Thanks to their 2 analogue inputs, DIRIS Digiware IO-20 modules can collect data from analogue sensors (pressure, humidity, temperature...).

All the information reported by the IO-10 and IO-20 modules can be viewed on DIRIS Digiware D-xx displays and on Webview, the web server embedded in DIRIS G gateways and in the DIRIS Digiware D-70 display unit.

Advantages

Plug & Play

The IO modules can be easily added anywhere within the measurement system thanks to a quick RJ45 connection.

Multifunction

The combination of voltage measuring modules, current measuring modules, and input/output modules makes DIRIS Digiware a complete and versatile system.

Integrated

All the reported information is accessible from the displays, from WEBVIEW or any other centralised management software.

Compact

The modular format allows the quick connection of a large number of IO-10 and IO-20 modules.

The solution for

- > Industry
- > Building
- > Data center



Strong points

- > Plug & Play
- > Multifunction
- > Integrated
- > Compact

Compliance with standards

- > IEC 61557-12
- > IEC 61010



- > ISO 14025



- > UL



Create your project

- > Find the best DIRIS Digiware configuration:
www.meter-selector.com



Application diagram

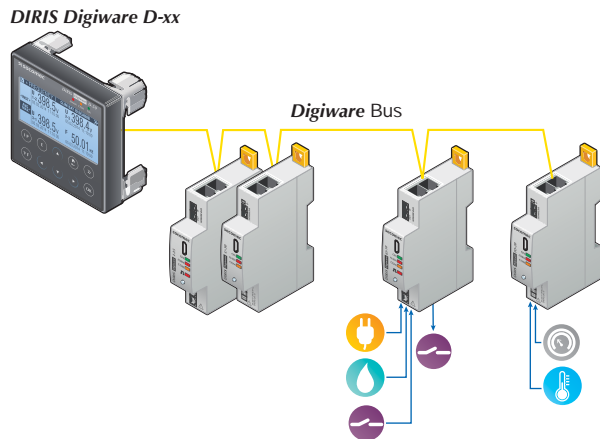

Connections

DIRIS Digiware IO-10

Digital inputs/outputs

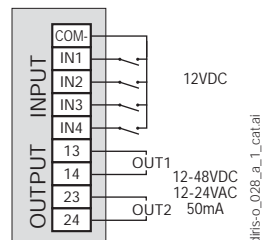

Digiware Bus

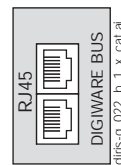

DIRIS Digiware IO-20

Analogue inputs

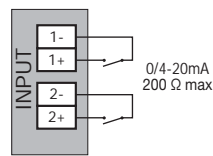

Digiware Bus

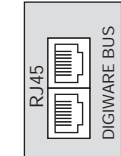

Dimensions (mm)

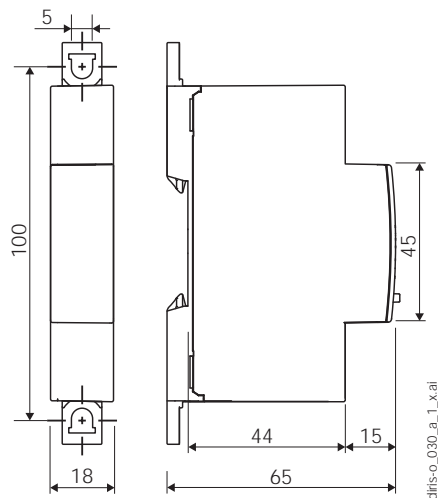

Technical characteristics

Measuring characteristics

Digital inputs/outputs- DIRIS Digiware IO-10

Number of inputs	4
Type/power supply	Insulated input, internal polarisation 12 VDC max., 3 mA
Input function	- Status of third-party devices - Monitoring of protective devices (ON/OFF, Trip) - Pulse counter
Number of outputs	2
Type	Insulated output, 48 VDC max., 50 mA and 24 VAC max.
Output function	- Remote control of devices - Alarm signal linked to the inputs (exceeding threshold, status...)
Input/output connection	Removable screw terminal block, 9 positions (5 dedicated to inputs, 4 dedicated to outputs) Stranded or solid 0.14 to 1.5 mm ² cable

Analogue inputs - DIRIS Digiware IO-20

Number of inputs	2
Type/power supply	0/4-20 mA, 200 Ω max
Accuracy	0.5% full scale
Function	Connection of analogue sensors (pressure, humidity, temperature...) with choice of interpolation (linear or quadratic)
Input connection	Removable screw terminal block 2x2 positions, Stranded or solid 0.14 to 1.5 mm ² cable

References

Digiware connection cables		Reference
RJ45 cables for Digiware Bus	Length 0.06 m	4829 0189
	Length 0.10 m	4829 0181
	Length 0.20 m	4829 0188
	Length 0.50 m	4829 0182
	Length 1 m	4829 0183
	Length 2 m	4829 0184
	Length 3 m	4829 0190
	Length 5 m	4829 0186
	Length 10 m	4829 0187
	Reel 50 m + 100 connectors	4829 0185
Termination for Digiware Bus (supplied with interfaces C and D)		4829 0180
USB configuration cable		4829 0050

DIRIS Digiware input/output modules		Reference
IO-10	4 digital inputs/2 outputs module	4829 0140
IO-20	2 analogue input module	4829 0145

Selection guide

Active energy meters and pulse concentrators

COUNTIS E

Which type
of network?



Which load
current?

Network - Input current	Single-phase Direct up to 40 A			Single-phase Direct up to 80 A				Three-phase Direct up to 80 A	
Active energy meters: <i>COUNTIS E</i>	<i>E00/E02</i> <i>p. 344</i>	<i>E03/E04</i> <i>p. 344</i>	<i>E05/E06</i> <i>p. 344</i>	<i>E11/E12</i> <i>p. 346</i>	<i>E13/E14</i> <i>p. 346</i>	<i>E15/E16</i> <i>p. 346</i>	<i>E17/E18</i> <i>p. 346</i>	<i>E21/E22</i> <i>p. 348</i>	<i>E23/E24</i> <i>p. 348</i>

Main specifications

MID: EN 50470 module B + D certification	• (E02)	• (E04)	• (E06)	• (E12)	• (E14)	• (E16)	• (E18)	• (E22)	• (E24)
RS485 Modbus		•			•				•
M-Bus			•			•			
Ethernet Modbus TCP/RTU							•		
Width	1 module	1 module	1 module	2 modules	2 modules	2 modules	2 modules	4 modules	4 modules
Input voltage	230 VAC	230 VAC	230 VAC	230 VAC	230 VAC	230 VAC	230 VAC	230 ... 400 VAC	230 ... 400 VAC

Functions

Total/partial energy kWh	•/•	•/•	•/•	•/•	•/•	•/•	•/•	•/•	•/•
Active power / Reactive power	•/•	•/•	•/•	•/•	•/•	•/•	•/•	•/•	•/•
Dual tariff for kWh		•	•	•	•	•	•	•	•
Total/partial energy kvarh	•/•	•/•	•/•	•/•	•/•	•/•	•/•	•/•	•/•
kVA		via COM	via COM		•	•	•	•	•
Load curve									
Measurement (I, V, P, Q, S, F and PF)	•	•	•	•	•	•	•	•	•
CT connection indication									
Birectional (energy consumption and production)	•	•	•	•	•	•	•	•	•
Integrated web server							•		
Compatibility with Webview		•			•		•		•

Accuracy

Active energy (IEC 62053-21)	class 1	class 1	class 1	class 1	class 1	class 1	class 1	class 1	class 1
Reactive energy (according to IEC 62053-23)	class 2	class 2	class 2	class 2	class 2	class 2	class 2	class 2	class 2
Active energy (EN 50470)	class B (E02)	class B (E04)	class B (E06)	class B (E12)	class B (E14)	class B (E16)	class B (E18)	class B (E22)	class B (E24)

Characteristics

Metrological LED	•	•	•	•	•	•	•	•	•
Pulse output	100 Wh	100 Wh	100 Wh	100 Wh	100 Wh	100 Wh		100 Wh	100 Wh
Sealing cover (MID version only)	• (E02)	• (E04)	• (E06)	• (E12)	• (E14)	• (E16)	• (E18)	• (E22)	• (E24)
Phase/neutral inversion protection									

Pulse concentrator	<i>COUNTIS ECi2</i> <i>p. 356</i>	<i>COUNTIS ECi3</i> <i>p. 356</i>
Case	4 modules	4 modules
Logical inputs	7	7
Analogue inputs		2
ON/OFF output (alarm)	1	1
Partial, total, daily, weekly or monthly kWh or other types of data (liters, m ³ ...)	•	•
Load curve from 8 to 30 minutes	•	•
RS485 Modbus	•	•



Three-phase Direct up to 80 A		Three-phase Direct up to 100 A			Three-phase CT 1/5 A				Three-phase CT/5 A	
<i>E25/E26</i> <i>p. 348</i>	<i>E27/E28</i> <i>p. 348</i>	<i>E30/E31/E32</i> <i>p. 350</i>	<i>E33/E34</i> <i>p. 350</i>	<i>E35/E36</i> <i>p. 350</i>	<i>E41/E42</i> <i>p. 352</i>	<i>E43/E44</i> <i>p. 352</i>	<i>E45/E46</i> <i>p. 352</i>	<i>E47/E48</i> <i>p. 352</i>	<i>E50</i> <i>p. 354</i>	<i>E53</i> <i>p. 354</i>
• (E26)	• (E28)	• (E32)	• (E34)	• (E36)	• (E42)	• (E44)	• (E46)	• (E48)		
			•			•				•
•				•			•			
	•							•		
4 modules	4 modules	7 modules	7 modules	7 modules	4 modules	4 modules	4 modules	4 modules	96x96	96x96
230 ... 400 VAC	230 ... 400 VAC	230 ... 400 VAC	230 ... 400 VAC	230 ... 400 VAC	230 ... 400 VAC	230 ... 400 VAC	230 ... 400 VAC	230 ... 400 VAC	86 ... 520 VAC	86 ... 520 VAC
•/•	•/•	•/• (E31)	•/via COM (E34)	•/via COM (E36)	•/•	•/•	•/•	•/•	•/•	•/•
•/•	•/•	•/-	•/via COM	•/via COM	•/•	•/•	•/•	•/•	•/•	•/•
•	•	• (E31/E32)	up to 4 via com	up to 4 via com	•	up to 4 via com	up to 4 via com	up to 4 via com	•	•
•/•	•/•		via COM	via COM	•/•	•/•	•/•	•/•	•	•
•	•		via COM	via COM	•	•	•	•	•	•
			via COM	via COM		via COM	via COM	via COM		
•	•		via COM	via COM	•	•	•	•	•	•
					•	•	•	•	•	•
•	•		• (E33)	• (E35)	•	•	•	•		
	•							•		
	•		•			•		•		•
class 1	class 1	class 1	class 1	class 1	class 1	class 1	class 1	class 1	class 1	class 1
class 2	class 2				class 2	class 2	class 2	class 2	class 2	class 2
class B (E26)	class B (E28)	class B (E32)	class B (E34)	class B (E36)	class C (E42)	class C (E44)	class C (E46)	class C (E48)		
•	•	•	•	•	•	•	•	•		
100 Wh	100 Wh				configurable	configurable	configurable	configurable		
• (E26)	• (E28)	• (E32)	• (E34)	• (E36)	• (E42)	• (E44)	• (E46)	• (E48)		
		•	•	•				•	•	•

COUNTIS E0x

Active energy meters for electrical distribution
single-phase - direct 40 A



COUNTIS E04 - MID

Function

The COUNTIS E0x is a modular electrical power meter. It shows kWh and kVAh readings and other measurements on its backlit LCD. These devices connect directly to a 40 A circuit. The COUNTIS E0x is fully integrated into the SOCOMEC monitoring ecosystem (Webview, screens, gateways, configuration software, etc.). COUNTIS E02, E04 and E06 are MID-certified.

Advantages

Compact

Only one module wide.

Communication via RS485 MODBUS, M-BUS or pulse output

COUNTIS E0x units have either one pulse output or an RS485 (MODBUS) or M-BUS communication output.

The pulse output transmits the consumption reading in kWh to a remote system (PC/BMS) so you can use it for billing purposes, to save energy and manage your energy costs.

B+D module, MID-certified

COUNTIS E units meet MID standards and ensure accurate and reliable metering (all crucial prerequisites of power-billing applications).

The "module B+D" certification proves that an external laboratory has verified the design and production process of these devices.

Socomec monitoring ecosystem: user software, remote displays

Inherent compatibility with energy management systems and Socomec gateways (Webview, screens, gateways, etc.).

Functional diagram

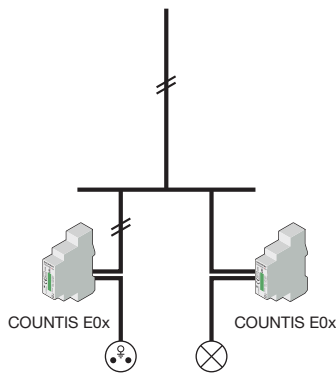

count_211_a_1_x_cat.eps

Common characteristics

- Compact
- Measurement accuracy: 1%.
- Displayed on backlit screen.
- Multiple measurements on-screen.

Models	Specific features
E00	Output (pulses)
E02	Pulse output + MID
E03	Dual-tariff + pulse output + communication via RS485 MODBUS
E04	Dual-tariff + pulse output + communication via RS485 MODBUS + MID
E05	Dual-tariff + pulse output + communication via M-BUS
E06	Dual-tariff + pulse output + communication via M-BUS + MID

The solution for

- > Data centre
- > Building
- > Industrial process



Strong points

- > Compact
- > Communication via RS485 MODBUS, M-BUS or pulse output
- > B+D module, MID-certified
- > Socomec monitoring ecosystem: user software, remote displays

MID certification

- > COUNTIS E units meet MID standards and provide accurate and reliable metering for power-billing applications.
- > The COUNTIS E MID has tamper-proof accessories to prevent fraud.



Compliance with standards

- > IEC 62053-21 Class 1
- > IEC 62053-23 Class 2
- > IEC 62053-31
- > IEC 62052-11
- > EN 50470-1
- > EN 50470-3



Associated current transformers



See "Current transformers".

Front panel

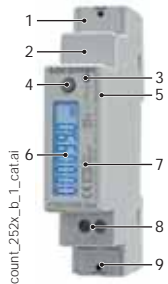

1. Neutral terminal with terminal shroud (COUNTIS E02/E04/E06).
2. M-Bus/MODBUS connection.
3. Metrological LED.
4. Navigation button.
5. Serial number.
6. Backlit LCD.
7. MID marking (COUNTIS E02/E04/E06).
8. Pulse output.
9. Voltage and current terminals.

Dimensions (mm)

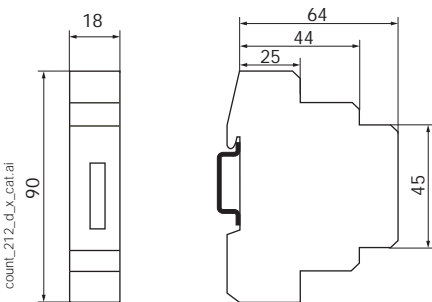

Type	Modular
Number of modules	1
Dimensions W x H x D	18 x 90 x 64 (mm)
Casing protection degree	IP 20
Front panel protection degree	IP 51 ⁽¹⁾
Display type	LCD 7 digits with backlighting
Cross-section of rigid connecting cable	1.5 to 6 mm ²
Cross-section of flexible connecting cable	1.5 to 6 mm ²
Weight	100 g E03/E04 80 g E00/E02/E05/E06

⁽¹⁾ Cabinet installations require a protection degree of at least IP51.

Electrical characteristics

Current monitoring (TRMS)		
Type	Single-phase - direct 40 A	
Input consumption	Max. 0.5 VA	
Permanent overload	40 A	
Transient overload	30 I _{max} over 10 ms	
Inrush current (I _{cfst} /c _f)	20 mA	
Minimum current (I _{min})	0.25 A	
Transient current (I _{cftr} /c _f)	0.5 A	
Reference current (I _{ref})	5 A	
Voltage measurements (TRMS)		
Measurement range	184 to 276 V AC	
Input consumption	1.5 VA max. E00/E02/E03/E04 1 VA max. E05/E06	
Permanent overload	280 V AC	
Power monitoring accuracy		
Active (according to IEC 62053-21)	Class 1	
Active (according to EN 50470)	Class B	
Reactive (according to IEC 62053-22)	Class 2	
Power supply		
Self-powered	Yes	
Frequency	50/60 Hz	
Output (pulses)		
Number	1	
Type of optical coupler	27 V DC - 27 mA (IEC 62053-31)	
Fixed pulses	100 Wh	
Pulse duration	100 ms	
Environment		
Operating temperature	-25 to +55°C	
Storage temperature	-40 to +75°C	
Relative humidity	80%	
Communication		
Link	COUNTIS E03/E04	COUNTIS E05/E06
Type	RS485	Wired
Type	2 to 3 half duplex wires	2 half duplex
Protocol	MODBUS in RTU mode	M-Bus
Baudrate	2400 to 38400 bauds	300, 2400, 9600 bps

Connections

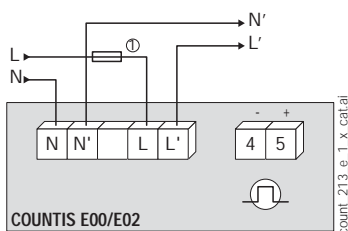

N - L: network input.

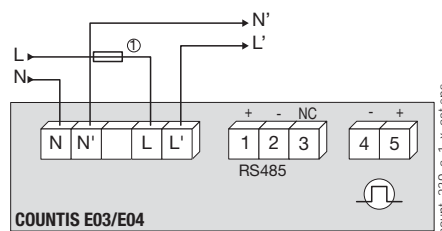

N' - L': network output.

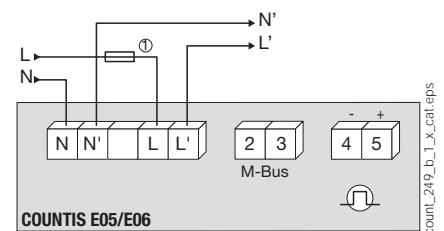

1. 0.5 A gG / 0.5 A class CC fuses.

References

Type	COUNTIS E00 Reference	COUNTIS E02 Reference	COUNTIS E03 Reference	COUNTIS E04 Reference	COUNTIS E05 Reference	COUNTIS E06 Reference
Direct 40 A	4850 3058					
Direct 40 A - MID		4850 3059				
Direct 40 A - Dual-tariff + communication via RS485 MODBUS			4850 3039			
Direct 40 A - Dual-tariff + communication via RS485 MODBUS + MID				4850 3040		
Direct 40 A - Dual-tariff + communication via M-BUS					4850 3041	
Direct 40 A - Dual-tariff + communication via M-BUS + MID						4850 3042
Accessories	Available for order in multiples of				Reference	
10x 1U sealing kits					4850 305U	
Fuse disconnect switches for voltage input protection (RM type) 1-pole	6				5702 5001	
gG 14x51 40 A fuses	10				6022 0040	

COUNTIS E1x

Active energy meters for electrical distribution
single-phase - direct 80 A



COUNTIS E14 - MID

Function

The COUNTIS E1x is a modular electrical power meter. It shows kWh, kVAh and kVA readings and other measurements on its backlit LCD. These devices are suited to single-phase power metering with a direct connection up to 80 A.

The COUNTIS E1x is fully integrated into the SOCOMEC monitoring ecosystem (Webview, screens, gateways, configuration software, etc.).

Advantages

Communication via RS485 (MODBUS), M-Bus, Ethernet or pulse outputs

COUNTIS E1x units have either one pulse output or one RS485 (MODBUS), M-Bus or Ethernet Modbus TCP communication output.

Multi-tariff

Allows you to assign energy metering to different time slots (every hour, off-peak hours) or different sources (normal, replacement) to accurately monitor energy consumption.

B+D module, MID-certified

COUNTIS E units meet MID standards and ensure accurate and reliable metering, all crucial prerequisites of power-billing applications. The "module B+D" certification proves that an external laboratory has verified the design and production process of these devices.

Socomec monitoring ecosystem: user software, remote displays

Inherent compatibility with energy management systems and Socomec gateways (Webview, screens, gateways, etc.).

Functional diagram

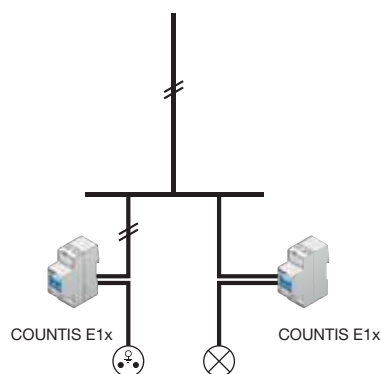

count_223_b_1_x_cat.eps

Common characteristics

- Measurement accuracy: 1%.
- Displayed on backlit screen.
- Multiple measurements on-screen.
- Compact.

Models	Specific features
E11	Dual-tariff + pulse output
E12	Dual-tariff + pulse output + MID
E13	Dual-tariff + pulse output + communication via RS485 MODBUS
E14	Dual-tariff + pulse output + communication via RS485 MODBUS + MID
E15	Dual-tariff + pulse output + communication via M-BUS
E16	Dual-tariff + pulse output + communication via M-BUS + MID
E17	Dual tariff + Ethernet
E18	Dual-tariff + Ethernet + MID

The solution for

- > Data centre
- > Building
- > Industrial process



Strong points

- > Communication via RS485 (MODBUS), M-Bus, Ethernet or pulse outputs
- > Multi-tariff
- > B+D module, MID-certified
- > Socomec monitoring ecosystem: user software, remote displays

MID certification

- > COUNTIS E units meet MID standards and provide accurate and reliable metering for power-billing applications.
- > The COUNTIS E MID has tamper-proof accessories to prevent fraud.



Compliance with standards

- > IEC 62053-21 Class 1
- > IEC 62053-23 Class 2
- > IEC 62053-31
- > IEC 62052-11
- > EN 50470-1
- > EN 50470-3



Associated current transformers



See "Current transformers".

Front panel



1. Serial number.
2. Backlit LCD.
3. MID marking (COUNTIS E12/E14/E16/E18).
4. Metrological LED.
5. Navigation button.
6. Voltage, current, neutral terminals with terminal shrouds (COUNTIS E12/E14/E16/E18).

Dimensions (mm)

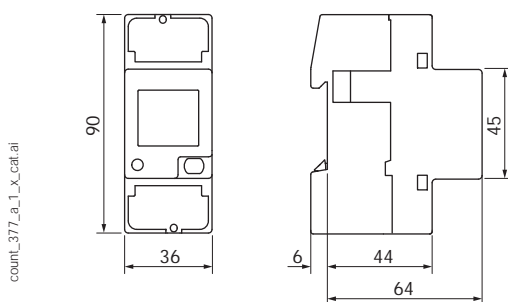

Type	Modular
Number of modules	2
Dimensions W x H x D	36 x 90 x 64 mm
Casing protection degree	IP 20
Front panel protection degree	IP 51 ⁽¹⁾
Display type	Backlit LCD
Cross-section of rigid connecting cable	1.5 to 35 mm ²
Cross-section of flexible connecting cable	1.5 to 35 mm ²
Weight	215 g E13/E14/E17/E18 205 g E11/E12/E15/E16

⁽¹⁾ Cabinet installations require a protection degree of at least IP51.

Electrical characteristics

Measurement of currents			
Type	Single-phase - direct 80 A		
Input consumption	Max. 0.5 VA		
Inrush current (I _{cfst} /c _f)	20 mA		
Minimum current (I _{min})	0.25 A		
Transient current (I _{cftr} /c _f)	0.5 A		
Reference current (I _{ref})	5 A		
Permanent overload (I _{max})	80 A		
Transient overload	30 I _{max} over 10 ms		
Voltage measurement			
Measurement range	230 to 240 V ± 20%		
Consumption (VA)	3.5 VA max. E13/E14/E17/E18 7.5 VA max. E11/E12/E15/E16		
Permanent overload	290 V phase-neutral		
Power monitoring accuracy			
Active (according to IEC 62053-21)	Class 1		
Active (according to EN 50470)	Class B		
Reactive (according to IEC 62053-22)	Class 2		
Power supply			
Self-powered	Yes		
Frequency	50/60 Hz		
Output (pulses)			
Type of optical coupler (IEC 62053-31)	250 V AC/DC - 100 mA (E11/E12) 27 V DC - 27 mA (E13/E14/E15/E16)		
Number	1		
Fixed pulses	100 Wh		
Pulse duration	50 ± 2 ms ON time 30 ± 2 ms OFF time		
Environment			
Operating temperature	-25 to 55 °C		
Storage temperature	-25 to 75 °C		
Relative humidity	80%		
Communication			
Link	COUNTIS E13/14 RS485	COUNTIS E15/E16 Wired	COUNTIS E17/E18 RJ45
Type	2 half duplex 2-3 half duplex (E13/E14)		Bi-directional mode (full duplex)
Protocol	MODBUS [®] RTU	M-BUS	MODBUS TCP, HTTP, NTP, DHCP
Baudrate	1200 to 115200 bauds	300 to 9600 bauds	10/100 Mbps

Connections

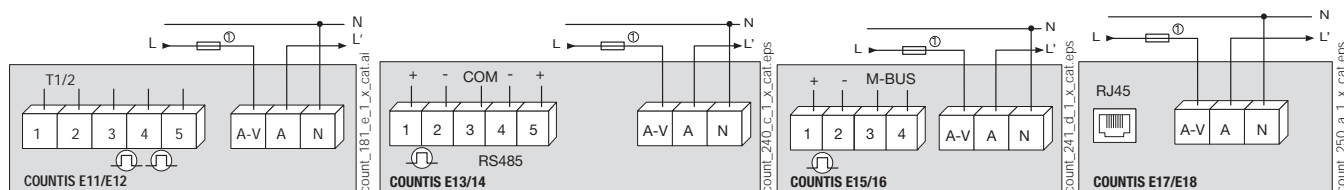

References

Type	COUNTIS E11 Reference	COUNTIS E12 Reference	COUNTIS E13 Reference	COUNTIS E14 Reference	COUNTIS E15 Reference	COUNTIS E16 Reference	COUNTIS E17 Reference	COUNTIS E18 Reference
Direct 80 A - Dual-tariff	4850 3060							
Direct 80 A - Dual-tariff + MID		4850 3061						
Direct 80 A - Dual-tariff + MODBUS communication via RS485			4850 3043					
Direct 80 A - Dual-tariff + MODBUS communication via RS485 + MID				4850 3044				
Direct 80 A - Dual-tariff + communication via M-BUS					4850 3045			
Direct 80 A - Dual-tariff + communication via M-BUS + MID						4850 3046		
Direct 80 A - Dual-tariff + communication via Ethernet Modbus TCP							4850 3047	
Direct 80 A - Dual-tariff + communication via Ethernet Modbus TCP + MID								4850 3048

Accessories	Available for order in multiples of	Reference
10x sealing kits, 2U		4850 306U
Fuse disconnect switches for voltage input protection (RM type) 1-pole	6	5703 5001
gG 22x58 80 A fuses	10	6032 0080

COUNTIS E2x

Active energy meters for electrical distribution
three-phase - direct 80 A



COUNTIS E24 - MID

Function

The COUNTIS E2x is a modular electrical power meter. It shows kWh, kVAh and kVa readings and other measurements on its backlit LCD. These devices are intended for three-phase networks and accommodate a direct connection up to 80 A.

The COUNTIS E2x is fully integrated into the SOCOMEC monitoring ecosystem (Webview, screens, gateways, configuration software, etc.).

Advantages

Communication via RS485 (MODBUS), M-Bus, Ethernet or pulse outputs

COUNTIS E2x units have either one pulse output or one RS485 (MODBUS), M-Bus or Ethernet Modbus TCP communication output.

Multi-tariff

Allows you to assign energy metering to different time slots (every hour, off-peak hours) or different sources (normal, replacement) to accurately monitor energy consumption.

B+D module, MID-certified

COUNTIS E units meet MID standards and ensure accurate and reliable metering (crucial prerequisites of power-billing applications). The "module B+D" certification proves that an external laboratory has verified the design and production process of these devices.

Socomec monitoring ecosystem: user software, remote displays

Inherent compatibility with energy management systems and Socomec gateways (Webview, screens, gateways, etc.).

Functional diagram

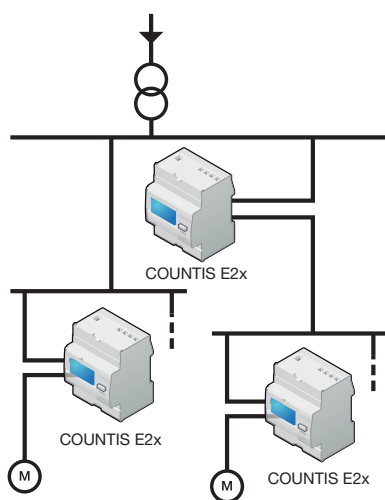

count_224_a_1_x_cat.eps

Common characteristics

- Measurement accuracy: 1%.
- Displayed on backlit screen.
- Multiple measurements on-screen.

Models	Specific features
E21	Dual-tariff + pulse output
E22	Dual-tariff + pulse output + MID
E23	Dual-tariff + pulse output + communication via RS485 MODBUS
E24	Dual-tariff + pulse output + communication via RS485 MODBUS + MID
E25	Dual-tariff + pulse output + communication via M-BUS
E26	Dual-tariff + pulse output + communication via M-BUS + MID
E27	Dual-tariff + pulse output + Ethernet
E28	Dual-tariff + pulse output + Ethernet + MID

The solution for

- > Data centre
- > Building
- > Industrial process



Strong points

- > Communication via RS485 (MODBUS), M-Bus, Ethernet or pulse outputs
- > Multi-tariff
- > B+D module, MID-certified
- > Socomec monitoring ecosystem: user software, remote displays

MID certification

- > COUNTIS E units meet MID standards and provide accurate and reliable metering for power-billing applications.
- > The COUNTIS E MID has tamper-proof accessories to prevent fraud.



Compliance with standards

- > IEC 62053-21 Class 1
- > IEC 62053-23 Class 2
- > IEC 62053-31
- > IEC 62052-11
- > EN 50470-1
- > EN 50470-3



Associated current transformers



See "Current transformers".

Front panel

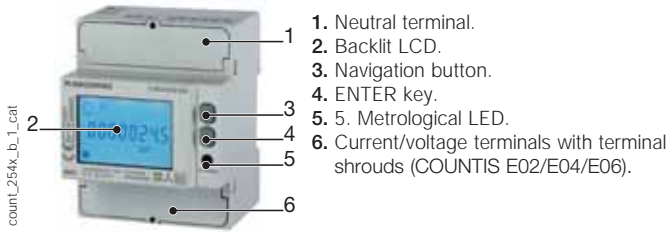

Dimensions (mm)

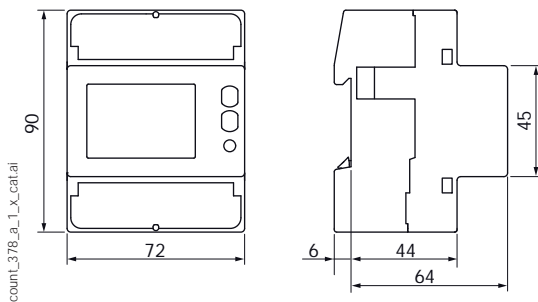

Type	Modular
Number of modules	4
Dimensions W x H x D	72 x 90 x 64 mm
Casing protection degree	IP 20
Front panel protection degree	IP 51 ⁽¹⁾
Display type	Backlit LCD, 8 digits
Cross-section of rigid connecting cable	1.5 to 35 mm ²
Cross-section of flexible connecting cable	1.5 to 35 mm ²
Weight	440 g

(1) Cabinet installations require a protection degree of at least IP51.

Electrical characteristics

Measurement of currents			
Type	Three-phase - direct 80 A		
Input consumption	0.5 VA max. per phase		
Inrush current (I _{cfst/cf})	20 mA		
Minimum current (I _{min})	0.25 A		
Transient current (I _{cftr/cf})	0.5 A		
Reference current (I _{ref})	5 A		
Permanent overload (I _{max})	80 A		
Transient overload	30 I _{max} over 10 ms		
Voltage measurement			
Measurement range	230 to 240 V ±20%		
Consumption (VA)	7.5 VA max. (0.5 W) per phase E21/E22/E25/E26 3.5 VA max. (1 W) per phase E23/E24/E27/E28		
Permanent overload	290 V phase-neutral / 500 V phase-phase		
Power monitoring accuracy			
Active (according to IEC 62053-21)	Class 1		
Active (according to EN 50470)	Class B		
Reactive (according to IEC 62053-22)	Class 2		
Power supply			
Self-powered	Yes		
Frequency	50/60 Hz		
Output (pulses)			
Type of optical coupler (IEC 62053-31)	250 V AC/DC - 100 mA (E21/E22) 27 V DC - 27 mA (E23 to E28)		
Number	2 (E21/E22) 1 (E23 to E28)		
Fixed pulse	100 Wh		
Pulse duration	50 ± 2 ms ON time 30 ± 2 ms OFF time		
Environment			
Operating temperature	-25 to 55°C		
Storage temperature	-25 to 75°C		
Relative humidity	80%		
Communication			
	COUNTIS E23/24	COUNTIS E25/ E26	COUNTIS E27/ E28
Link	RS485	Wired	RJ45
Type	2 half duplex 2 to 3 half duplex (E23/E24)		Bi-directional mode (full duplex)
Protocol	MODBUS in RTU mode	M-BUS	MODBUS TCP, HTTP, NTP, DHCP
Baudrate	1200 to 115200 bauds	300 to 9600 bauds	10/100 Mbps

Connections

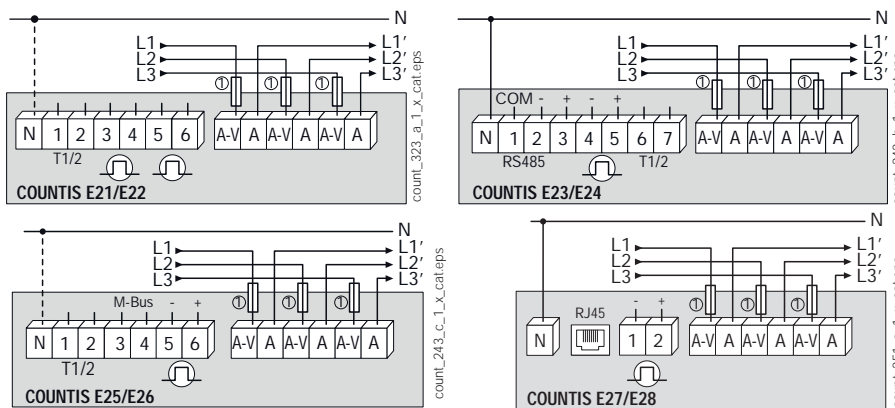

IMPORTANT: Neutral connection is mandatory on COUNTIS E23/E24/E27/E28 (neutral is represented by the solid line in the image opposite).

Neutral is optional on COUNTIS E21/E22/E25/E26 (neutral is represented by the dashed line in the image opposite).

1. 0.5 A gG / 0.5 A class CC fuses.

References

Type	COUNTIS E21 Reference	COUNTIS E22 Reference	COUNTIS E23 Reference	COUNTIS E24 Reference	COUNTIS E25 Reference	COUNTIS E26 Reference	COUNTIS E27 Reference	COUNTIS E28 Reference
Direct 80 A - Dual-tariff	4850 3062							
Direct 80 A - Dual-tariff + MID		4850 3049						
Direct 80 A - Dual-tariff + MODBUS communication via RS485			4850 3050					
Direct 80 A - Dual-tariff + MODBUS communication via RS485 + MID				4850 3051				
Direct 80 A - Dual-tariff + communication via M-BUS					4850 3052			
Direct 80 A - Dual-tariff + communication via M-BUS + MID						4850 3053		
Direct 80 A - Dual-tariff + communication via Ethernet Modbus TCP							4850 3054	
Direct 80 A - Dual-tariff + Ethernet Modbus TCP + MID								4850 3055
Accessories	Available for order in multiples of						Reference	
Panel mounting kit, 4 modules							192J 8015	
10x sealing kits, 4U							4850 309U	
Fuse disconnect switches for voltage input protection (RM type) 3-pole	2						5703 5003	
gG 22x58 80 A fuses	10						6032 0080	

COUNTIS E3x

Active energy meters for electrical distribution
three-phase - direct 100 A



COUNTIS E32 - MID

Function

The **COUNTIS E3x** is a modular electrical power meter. It shows power readings (kWh and kW) on its backlit LCD. These devices are intended for three-phase power metering and accommodate a direct connection up to 100 A.

The **COUNTIS E3x** is fully integrated into the **SOCOMECC** monitoring ecosystem (Webview, screens, gateways, configuration software, etc.).

COUNTIS E32, E34 and E36 are also MID-certified.

Advantages

Communication via RS485 (MODBUS or M-BUS) or pulse outputs

COUNTIS E3x units have either one pulse output or one RS485 MODBUS or M-BUS communication output.

Connection error detection

The devices are protected against phase/neutral inversion and detect wiring errors. Easy to install and commission – reduces costs and ensures the proper functioning of the devices.

B+D module, MID-certified

COUNTIS E units meet MID standards and ensure accurate and reliable metering (crucial prerequisites of power-billing applications). The "module B+D" certification proves that an external laboratory has verified the design and production process of these devices.

Functional diagram

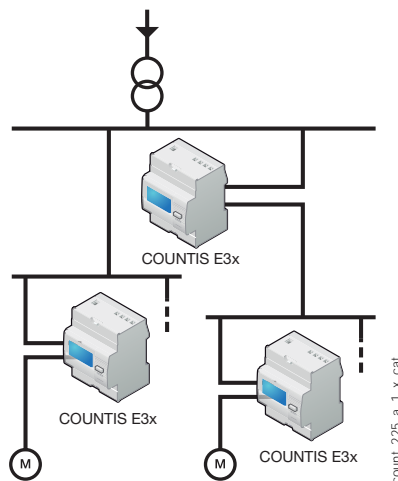

Multi-power monitoring and load curves

Shows electrical readings (I, U, V, P, Q, S, PF) and the load curve over a 7-day period via the communication methods.

Socomec monitoring ecosystem

Inherent compatibility with energy management systems and Socomec gateways (Webview, screens, gateways, etc.).

General characteristics

- Measurement accuracy: 1%
- Backlit LCD.
- Detects connection errors.

The solution for

- > Data centre
- > Building
- > Industrial process



Strong points

- > Communication via RS485 (MODBUS or M-BUS) or pulse outputs
- > Connection error detection
- > B+D modules are MID-certified, providing multi-power monitoring and load curves
- > Socomec monitoring ecosystem: user software, remote displays

MID certification

- > COUNTIS E units meet MID standards and provide accurate and reliable metering for power-billing applications.
- > The COUNTIS E MID has tamper-proof accessories to prevent fraud.



Compliance with standards

- > IEC 62053-21 Class 1
- > IEC 62053-31
- > IEC 62053-11
- > EN 50470-1
- > EN 50470-3



Associated current transformers



See "Current transformers".

Models	Main specifications
E30	Output (pulses)
E31	Dual-tariff (2 partial meters) + pulse output
E32	Dual-tariff + MID + pulse output
E33	Dual-tariff + communication via RS485 MODBUS
E34	Dual-tariff + communication via RS485 MODBUS + MID
E35	Dual-tariff + communication via M-BUS
E36	Dual-tariff + communication via M-BUS + MID

Front panel

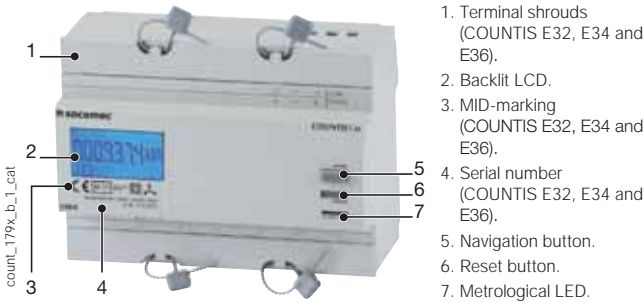

Dimensions (mm)

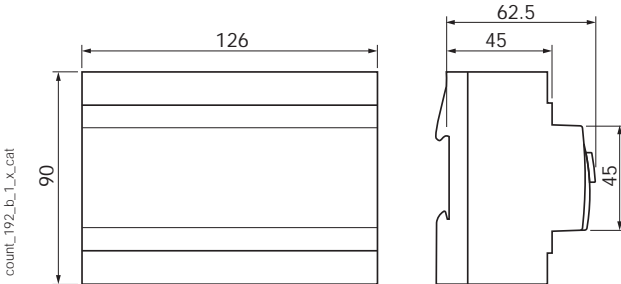

Type	Modular
Number of modules	7
Dimensions W x H x D	126 x 90 x 62.5 mm
Casing protection degree	IP20
Front panel protection degree	IP51
Display type	Backlit LCD
Cross-section of rigid connecting cable	2.5 to 35 mm ²
Cross-section of flexible connecting cable	2.5 to 35 mm ²
Weight	490 g

Electrical characteristics

Current measurement		
Type	Three-phase - direct 100 A	
Input consumption	0.5 VA max. per phase	
Inrush current (I _{cfst} /cf)	80 mA	
Minimum current (I _{min})	0.5 A ⁽¹⁾	
Transient current (I _{cftr} /cf)	2 A ⁽²⁾	
Reference current (I _{ref})	20 A ⁽³⁾	
Permanent overload (I _{max})	100 A	
Transient overload	3000 A over 10 ms	
Voltage measurement		
Measurement range	230 to 400 V ± 20%	
Consumption (VA)	2	
Permanent overload	280 V phase-neutral / 480 V phase-phase	
Power monitoring accuracy		
Active (according to IEC 62053-21)	Class 1	
Active (according to EN 50470)	Class B	
Power supply		
Self-powered	Yes	
Frequency	50 / 60 Hz	
Output (pulse) (COUNTIS E30/E31/E32)		
Number	1	
Type of optical coupler	IEC 62053-31 Class A (20 to 30 VDC)	
Fixed pulses	100 Wh	
Pulse duration	100 ms	
Environment		
Operating temperature	-10 to 55°C	
Storage temperature	-20 to 70°C	
Relative humidity	85%	
Communication		
Link	COUNTIS E33/34	COUNTIS E35/E36
Type	RS485	Master/Slave
Protocol	2-wire half duplex	2-wire half duplex
Protocol	MODBUS in RTU mode	M-BUS
Baudrate	4800 to 38400 bauds	300 to 9600 bauds

(1) $I_{min} \leq 0.5 \cdot I_{tr}$
 (2) Guaranteed accuracy between I_{tr} and I_{max} .
 (3) $I_{ref} = I_{(0)}$ (base current) = $10 \cdot I_{(0)}$ for direct connection COUNTIS devices.

Connections

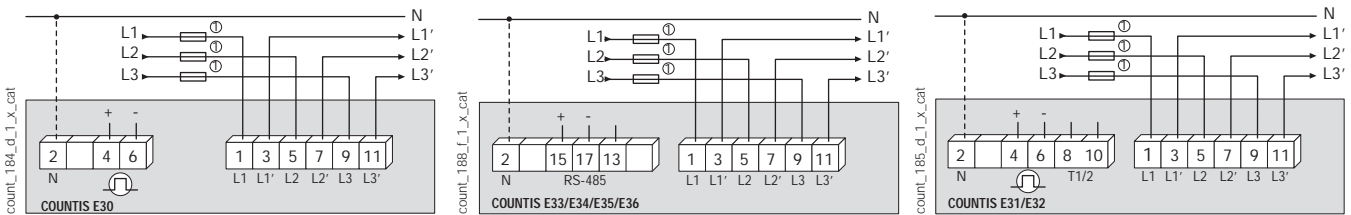

1. Max. 100 A gG / Am fuse

IMPORTANT: Neutral is optional on COUNTIS E3x (neutral is represented by the dashed line in the image opposite).

References

Type	COUNTIS E30 Reference	COUNTIS E31 Reference	COUNTIS E32 Reference	COUNTIS E33 Reference	COUNTIS E34 Reference	COUNTIS E35 Reference	COUNTIS E36 Reference
Direct 100 A	4850 3005						
Direct 100 A- Dual tariff		4850 3006					
Direct 100 A - Dual-tariff + MID			4850 3007				
Direct 100 A - Dual-tariff + MODBUS communication via RS485 ⁽¹⁾				4850 3012			
Direct 100 A - Dual-tariff + MODBUS communication via RS485 + MID ⁽¹⁾					4850 3013		
Direct 100 A - Dual-tariff + communication via M-BUS ⁽¹⁾						4850 3025	
Direct 100 A - Dual-tariff + communication via M-BUS + MID ⁽¹⁾							4850 3026

(1) 4-tariff via RS485 communication.

Accessories	Available for order in multiples of	Reference
10x sealing kits, 4U		4850 307U
Fuse disconnect switches for voltage input protection (RM type) 3-pole	2	5703 5003
gG 22x58 100 A fuses	10	6032 0100

COUNTIS E4x

Active energy meters for electrical distribution

three-phase – connect to current transformers up to 12000 A



count_347.psd

COUNTIS E44 - MID

The solution for

- > Data centre
- > Building
- > Industrial process



Strong points

- > Communication via RS485 (MODBUS), M-Bus, Ethernet or pulse outputs
- > B+D module, MID-certified
- > Bi-directional, multi-reading and load-curve metering
- > Socomec monitoring ecosystem: user software, remote displays
- > Multi-tariff

MID certification

- > COUNTIS E units meet MID standards and provide accurate and reliable metering for power-billing applications.
- > The COUNTIS E MID has tamper-proof accessories to prevent fraud.



Compliance with standards

- > IEC 62053-21 Class 1
- > IEC 62053-23 Class 2
- > IEC 62053-31
- > IEC 62053-11
- > EN 50470-1
- > EN 50470-3



Associated current transformers



See "Current transformers".

Function

The COUNTIS E4x is a modular electrical power meter. It shows kWh, kVAh and kVA readings and other measurements on its backlit LCD. These devices are intended for three-phase power metering via CT, they are suitable for applications up to 12000 A.

The COUNTIS E4x is fully integrated into the SOCOMEC monitoring ecosystem (Webview, screens, gateways, configuration software, etc.). COUNTIS E42, E44, E46 and E48 are MID-certified.

Advantages

Communication via RS485 (MODBUS), M-Bus, Ethernet or pulse outputs

COUNTIS E4x have either one or two pulse output(s), or one RS485 (MODBUS), M-BUS or Ethernet Modbus TCP communication output.

B+D module, MID-certified

COUNTIS E units meet MID standards and ensure accurate and reliable metering (crucial prerequisites of power-billing applications). The "module B+D" certification proves that an external laboratory has verified the design and production process of these devices.

Bi-directional, multi-reading and load-curve metering

In bi-directional mode, the device can measure both consumed and generated energy at the same time. Shows electrical readings (I, U, V, P, Q, S, PF) and the load curve over a 7-day period via the communication methods.

Functional diagram

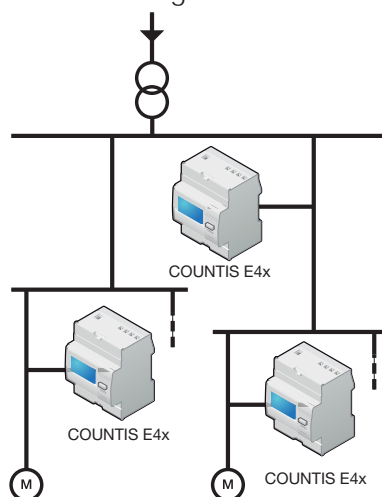

Socomec monitoring ecosystem

Inherent compatibility with energy management systems and Socomec gateways (Webview, screens, gateways, etc.).

Multi-tariff

Allows you to assign energy metering to different time slots (every hour, off-peak hours) or different sources (normal, replacement) to accurately monitor energy consumption.

General characteristics

- Measurement accuracy: 1% / 0.5% (MID).
- Backlit LCD.
- Multiple measurements on-screen.

Models	Specific features
E41	Dual-tariff + pulse output
E42	Dual-tariff + pulse output + MID
E43	4-tariff + pulse output + communication via RS485 MODBUS
E44	4-tariff + pulse output + communication via RS485 MODBUS + MID
E45	4-tariff + pulse output + communication via M-BUS
E46	4-tariff + pulse output + communication via M-BUS + MID
E47	4-tariff + pulse output + Ethernet
E48	4-tariff + pulse output + Ethernet + MID

Front panel

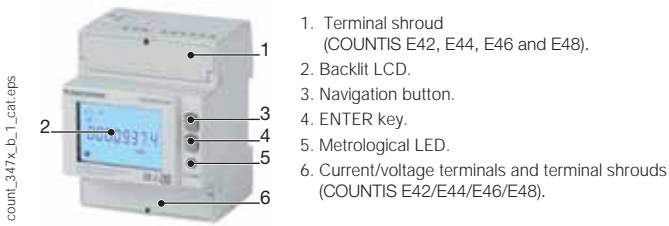

Dimensions (mm)

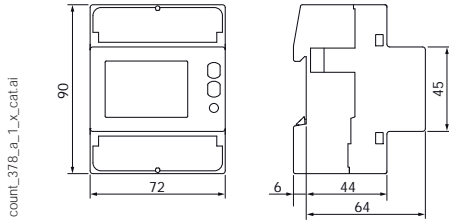

Type	Modular
Number of modules	4
Dimensions W x H x D	72 x 90 x 64 mm
Casing protection degree	IP20
Front panel protection degree	IP51
Display type	Backlit LCD, 8 digits
Cross-section of rigid connecting cable	1.5 to 6 mm ²
Cross-section of flexible connecting cable	1.5 to 6 mm ²
Weight	322 g

Connections

We recommend:

- Connecting CT secondaries is strictly prohibited with IT earthing arrangements; it is, however, optional in TT/TN earthing arrangements.
 - When disconnecting the COUNTIS device, it is essential to short-circuit the secondaries of each current transformer. This operation can be carried out automatically by a PTI, which can be found in the SOCOMEC catalogue.
- Contact us

IMPORTANT: Neutral connection is mandatory on COUNTIS E43 / E44 / E47 / E48 (neutral is represented by the solid line in the image opposite). Neutral is optional on COUNTIS E41 / E42 / E45 / E46 (neutral is represented by the dashed line in the image opposite).

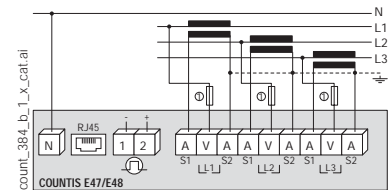
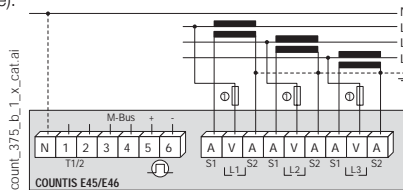
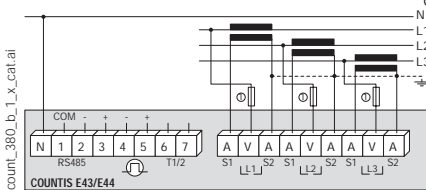
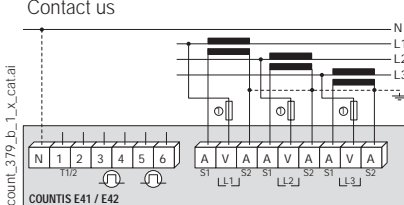

1. 0.5 A gG / 0.5 A class CC fuses.

References

Type	COUNTIS E41 Reference	COUNTIS E42 Reference	COUNTIS E43 Reference	COUNTIS E44 Reference	COUNTIS E45 Reference	COUNTIS E46 Reference	COUNTIS E47 Reference	COUNTIS E48 Reference
Via CT - Dual-tariff	4850 3063							
Via CT - Dual-tariff + MID		4850 3064						
Via CT - Dual-tariff + MODBUS communication via RS485 ⁽¹⁾			4850 3065					
Via CT - Dual-tariff + MODBUS communication via RS485 + MID ⁽¹⁾				4850 3066				
Via CT - Dual-tariff + communication via M-BUS ⁽¹⁾					4850 3067			
Via CT - Dual-tariff + communication via M-BUS + MID ⁽¹⁾						4850 3068		
Via CT - Dual-tariff + communication via Ethernet Modbus CTP ⁽¹⁾							4850 3056	
Via CT - Dual-tariff + communication via Ethernet Modbus CTP + MID ⁽¹⁾								4850 3057

(1) 4-tariff via RS485 communication.

Accessories	Available for order in multiples of	Reference
Panel mounting kit, 4 modules		192J 8015
10x sealing kits, 4U		4850 309U
Fuse disconnect switches for voltage input protection (RM type) 3-pole	2	5701 0018
gG 10x38 0.5 A fuses	10	6012 0000

Electrical characteristics

Current measurement			
Type	Three-phase on CT 1 and 5A up to 12000 A		
Input consumption	0.5 VA max. per phase		
Inrush current (I _{cfst/cf})	1 mA - Class C 2 mA - Class 1		
Minimum current (I _{min})	10 mA		
Transient current (I _{cftr/cf})	50 mA		
Reference current (I _{ref})	1 A		
Permanent overload (I _{max})	6 A		
Transient overload	120 A for 0.5 s		
Voltage measurement			
Measurement range	230 to 240 V ± 20%		
Consumption (VA)	Max. 7.5 VA (0.5 W) per phase E41/E42/E45/E46 Max. 3.5 VA (1 W) per phase E43/E44/E47/E48		
Permanent overload	290 V phase-neutral / 500 V phase-phase		
Power monitoring accuracy			
Active (according to IEC 62053-21)	Class 1		
Active (according to EN 50470)	Class C		
Reactive (according to IEC 62053-22)	Class 2		
Power supply			
Self-powered	Yes		
Frequency	50 / 60 Hz		
Output (pulses)			
Number	2 (E41/E42) 1 (E43 to E48)		
Type of optical coupler	250 V AC/DC - 100 mA (E41/E42) 27 V DC - 27 mA (E43 to E48)		
Pulses	1 Wh ⇒ CT = 1 to 4 5 Wh ⇒ TC = 5 to 24 25 Wh ⇒ TC = 25 to 124 125 Wh ⇒ TC = 125 to 624 1000 Wh ⇒ CT = 625 to 3124 10000 Wh ⇒ TC = 3125 to 12000		
Pulse duration	50 ± 2 ms ON time 30 ± 2 ms OFF time		
Environment			
Operating temperature	-25 to +55°C		
Storage temperature	-25 to +75°C		
Relative humidity	80%		
Communication			
	COUNTIS E43/E44	COUNTIS E45/E46	COUNTIS E47/E48
Link	RS485	Master/Slave	RJ45
Type	2 to 3 half duplex	2 half duplex	Bi-directional mode (full duplex)
Protocol	MODBUS in RTU mode	M-BUS	MODBUS CTP, HTTP, NTP, DHCP
Baudrate	1200 to 115200 bauds	300 to 9600 bauds	10/100 Mbps

COUNTIS E5x

Active energy meters for electrical distribution

three-phase – connect to current transformers up to 6000 A – door-mounted



COUNTIS E53 - up to 6000 A (via CT)

The solution for

- > Data centre
- > Building
- > Industrial process



Strong points

- > RS485 (MODBUS) communication or pulse outputs
- > Detection of connection errors
- > Large backlit screen
- > Multi-power monitoring and meter readings on-screen
- > Socomec monitoring ecosystem: user software, remote displays

Compliance with standards

- > IEC 62053-23 Class 2
- > IEC 62053-22 Class 0.5S
- > IEC 61557-12



Measurement index

- > 210

Related software

- > We offer a range of specially designed application tools, to help you make the most of your Socomec metering and monitoring devices.

Associated current transformers



See "Current transformers".

Function

The COUNTIS E5x is an active and reactive plug-in electrical energy meter intended for three-phase networks. It accommodates CT wiring up to 6000 A.

The COUNTIS E5x is fully integrated into the SOCOMEC monitoring ecosystem (Webview, screens, gateways, configuration software, etc.).

The user can configure the CT connection by using the keyboard and the display.

Advantages

RS485 (MODBUS) communication or pulse outputs

As an easy way to centralise your consumption readings, the COUNTIS E5x is equipped with either a pulse output or an RS485 MODBUS communication output.

Detection of connection errors

The COUNTIS E5x is protected against phase/neutral inversion and has an integrated test mode to detect wiring errors. Any installation errors can be corrected without having to re-arrange the wiring.

Easy to install and commission – reduces costs and ensures the proper functioning of the devices.

Large backlit screen

With its multi-display screen and hotkeys, the COUNTIS E5x is easy to use. It shows you your consumption and a wide range of electrical readings: I, U, V, S, FP, etc.

Multi-power monitoring and meter readings on-screen

- Multi-power monitoring:
Currents: realtime: I1, I2, I3
Voltages: realtime: V1, V2, V3, U12, U23, U31, F
Power: realtime 3P, 3Q, 3S, average, maximum: 3P
Power factor: realtime: 3PF

Functional diagram

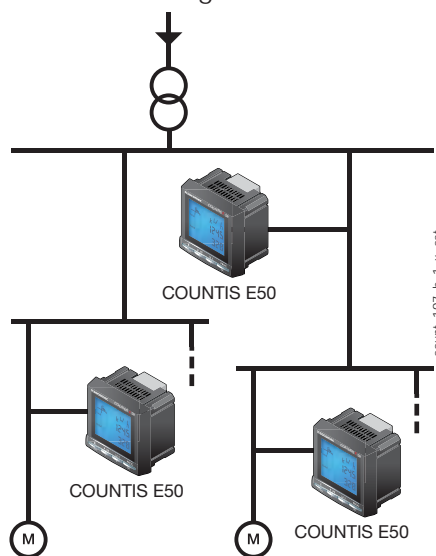

- Metering:
Active power: \pm kWh
Reactive power: \pm kvarh
Apparent power: kVAh

Socomec monitoring ecosystem: user software, remote displays

Inherent compatibility with energy management systems and Socomec gateways (Webview, screens, gateways, etc.).

General characteristics

- Measurement accuracy: 0.5%.
- Large backlit screen.
- Shows multi-measurement and meter readings on-screen.
- Connection guaranteed.

Models	Model-related specifications
E50	Pulse output
E53	RS485 MODBUS communication

Front panel



1. Backlit LCD
2. Button to show energy values and test mode
3. Button to show power readings and power factor
4. Button to show currents and voltages
5. Enter button for programming mode

Case

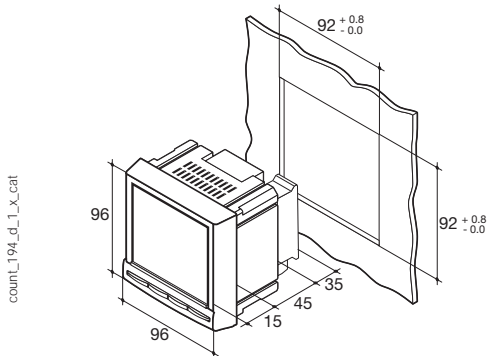

Type	Plug-in
Dimensions W x H x D	96 x 96 x 60 mm
Casing protection degree	IP30
Front panel protection degree	IP52
Display type	LCD with blue backlighting
Cross-section of cables for voltage and other terminals	0.5 to 2.5 mm ²
Cross-section of cables for current	1.5 to 6 mm ²
Weight	370 g

(1) $I_{min} \leq 0.5 \cdot I_N$

(2) Guaranteed accuracy index between I_{10} and I_{max} .

(3) $I_{ref} = I_{10}$ (base current) = $10 \cdot I_{10}$ for direct connection COUNTIS devices.

Electrical characteristics

Measurement of currents

Type	Three-phase on CT/5A up to 6000 A
Input consumption	< 0.6 VA
Startup current (I_{st})	40 mA
Minimum current (I_{min})	50 mA ⁽¹⁾
Transition current (I_T)	250 mA ⁽²⁾
Reference current (I_{ref})	5 A ⁽³⁾
Permanent overload (I_{max})	6 A
Intermittent overload	50 A for 1 s

Voltage measurement

Range of measurement	86 to 520 VAC
Input consumption	< 0.1 VA
Permanent overload	800 VAC

Power accuracy

Reactive (according to IEC 62053-23)	Class 2
Active (according to IEC 62053-22)	Class 0.5s

Power supply

Self-powered	No
Auxiliary power supply U_s	110 to 400 VAC / 125 to 350 VDC $\pm 10\%$
Frequency	45 to 65 Hz

Output (pulses)

Number	1
Type	100 VDC - 0.5 A - 10 VA
Max. number of actions	$\leq 10^8$

Operating conditions

Operating temperature	-10 to 55°C
Storage temperature	-20 to 85°C
Relative humidity	95%

Communication

Link	RS485
Type	2 to 3 half duplex wires
Protocol	MODBUS® RTU
MODBUS® speed	1400 to 38400 bauds

References

Type	COUNTIS E50 Reference	COUNTIS E53 Reference
Output (pulses)	4850 3010	
MODBUS RS485 communication ⁽¹⁾		4850 3011
COUNTIS software		

(1) 4-tariff via RS485 communication.

Accessories	Available for order in multiples of	Reference
Fuse disconnect switches for voltage input protection (RM type) 3-pole	4	5701 0018
Fuse disconnect switches to protect the 1-pole + neutral auxiliary power supply (RM type)	6	5701 0017
gG 10x38 0.5 A fuses	10	6012 0000

Connection

Recommendation:

- With an IT arrangement, you are recommended not to earth CT secondaries.

- When disconnecting the COUNTIS device, the secondary of each current transformer must be short-circuited. This operation can be carried out automatically by a PTI, which can be found in the SOCOMEC catalogue. Contact us.

Low voltage balanced network

3/4 wires with 1 CTs

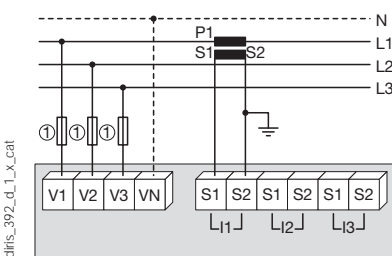

The use of 1 CT reduces the accuracy of the phase from which the current is derived by 0.5% (using a vector calculation).

Low voltage unbalanced network

3/4 wires with 3 CTs

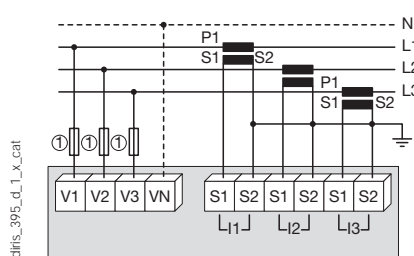

3 wires with 2 CTs

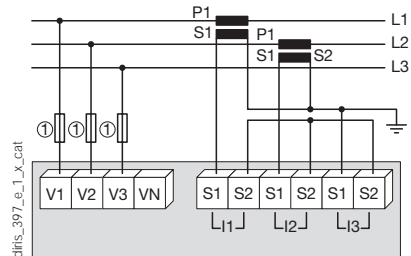

The use of 2 CTs reduces the accuracy of the phase from which the current is derived by 0.5% (using a vector calculation).

Additional information

Communication via RS485 link

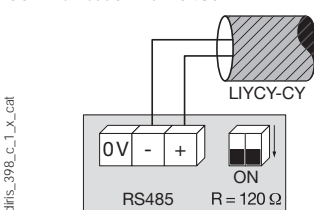

AC and DC auxiliary power supply

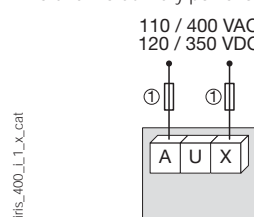

1. 0.5 A gG / 0.5 A class CC fuses.

COUNTIS ECix

multifluid pulse concentrator



COUNTIS ECi3

The solution for

- > Data centres
- > Industry
- > Infrastructure



Strong points

- > Up to 7 multifluid meters and 2 analogue sensors
- > Load curves
- > RS485 MODBUS communication
- > Improved customisation

Management software

- > To get the most effective use from your Socomec measurement and metering devices, we offer a range of dedicated software tools.

Function

The COUNTIS ECix is a multifluid pulse concentrator which communicates via an RS485 link using MODBUS protocol.

It enables pulses from water, gas, compressed air, electricity meters and, for the COUNTIS ECi3, the output of analogue sensors (light, temperature, wind etc.) to be registered and stored. All data, ie. total and partial meters and load curves (available for all logical and analogue inputs) can be centralised via RS485 communication using MODBUS protocol.

Principle diagram

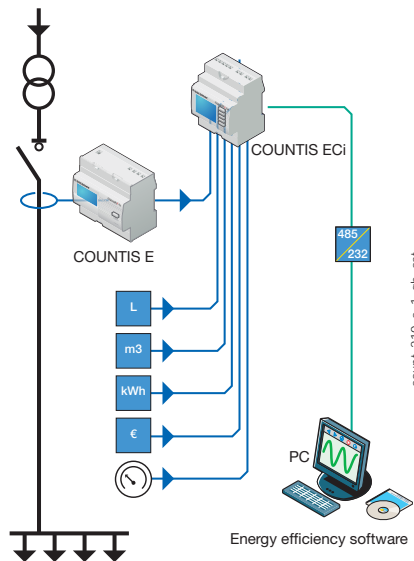

Advantages

Up to 7 multifluid meters and 2 analogue sensors

- 7 digital inputs + 2 analogue inputs.
- Total, partial and programmable metering (day, week, month, year).

Load curves

Load curves are available for each of the 7 logical inputs.

A history of average values are available for the 2 analogue inputs (ECi3).

RS485 MODBUS communication

- Centralisation and transmission of pulse and analogue data to a supervision station.
- Remote configuration of COUNTIS ECi device.

Improved customisation

- Selection of the measuring unit: kWh, m³, liters.
- Selection of the currency unit: €, K€, £, \$.

Values can be displayed in the unit of your choice and energy costs can be directly calculated.

Models	Key characteristics
ECi2	7 insulated inputs
ECi3	7 insulated inputs + 2 analogue inputs.

Front panel

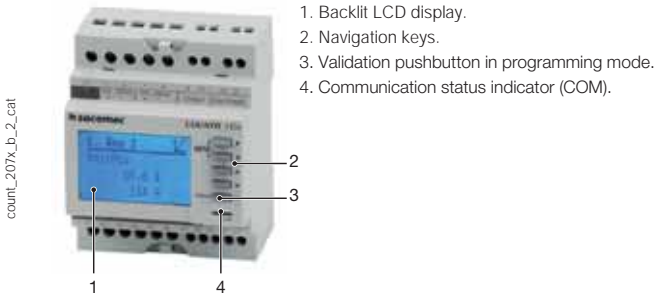

Dimensions (mm)

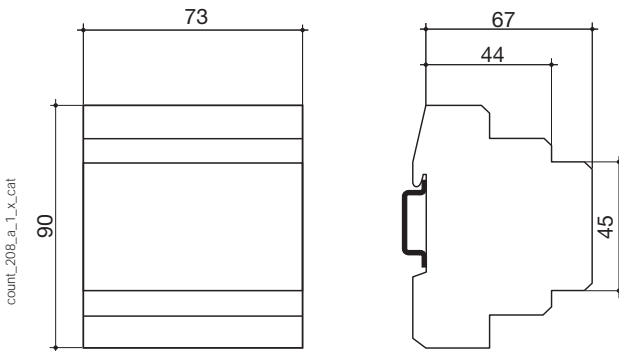

Type	modular
Number of modules	4
Dimensions W x H x D	73 x 90 x 67 mm
Case degree of protection	IP20
Front degree of protection	IP51
Display type	backlit LCD display
Terminal blocks type	fixed
Rigid cable cross-section	1 ... 10 mm ²
Flexible cable cross-section	0.5 ... 6 mm ²
Weight	215 g

Characteristics

Auxiliary power supply	
Self-supplied	no
Alternating voltage	110 / 400 VAC
Direct voltage	120 / 300 VDC
Tolerance	± 10 %
Frequency	45 / 65 Hz
Consumption	5 VA
Insulation voltage	3.5 kV
Communication	
Link	RS485
Type	2 ... 3 half duplex wires
Protocol	MODBUS RTU
MODBUS [®] speed	9600 ... 38400 bauds
Inputs	
Number	7
Control voltage (integrated)	10...30 VDC
Minimum signal width	10 ms
Maximum signal width	2 s
Minimum duration between 2 pulses	30 ms
Edge triggering	rising
Analogue inputs (ECi3)	
Number	2
Current	25 mA
Accuracy	0.5 %
Response time	500 ms
Input resistance	200 Ω
Consumption	0.1 VA
Operating conditions	
Operating temperature	-10 ... +55 °C
Storage temperature	-20 ... +70 °C
Relative humidity	95 %

Connection

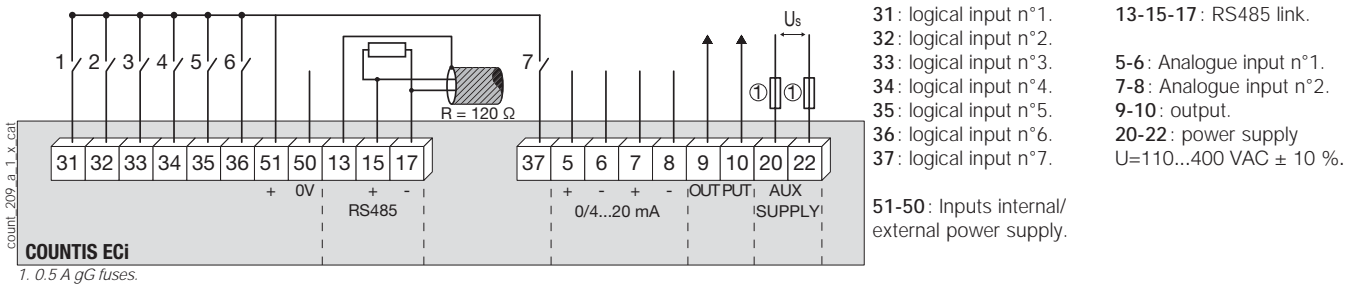

References

Auxiliary power supply U _s	COUNTIS ECi2 Reference	COUNTIS ECi3 Reference
230 / 400 VAC	4853 0000	
230 / 400 VAC + 2 analogue inputs		4853 0001
Accessories	To be ordered in multiples of	Reference
Door mounting kit		192J 8015
Fuse disconnect switches to protect the 1-pole + neutral auxiliary power supply (RM type)	6	5701 0017
gG 10x38 0,5 A fuses	10	6012 0000

MULTIS L50

Digital panel meter

three-phases - via CT up to 6000 A dimensions 96 x 96 mm



MULTIS L50

The solution for

- > Industry
- > Infrastructure



Strong points

- > Large backlit LCD display
- > Direct display of multimeasurement and metering values
- > RS485 MODBUS communication
- > Inputs/Output for control/command or pulses

Conformity to standards

- > IEC 62053-21 class 1
- > IEC 62053-23 class 2



Function

The MULTIS L50 is a panel mounted digital meter displaying multi-measurement and energy values directly on its large backlit LCD display. It is designed for utilisation on three-phase or single-phase networks with connection via CT and is suitable for applications of up to 6000 A. The product can be configured by the user via the keypad and the display.

Advantages

Easy to use

Thanks to its large backlit LCD display and its multiple viewing screens with direct pushbutton access, MULTIS L50 provide clear readings and are easy to use. They directly display a number of multi-measurement and metering values.

Advanced functionalities

The MULTIS L50 offers input/output functions as standard and has a pulse output or RS485 MODBUS communication output.

Principle diagram

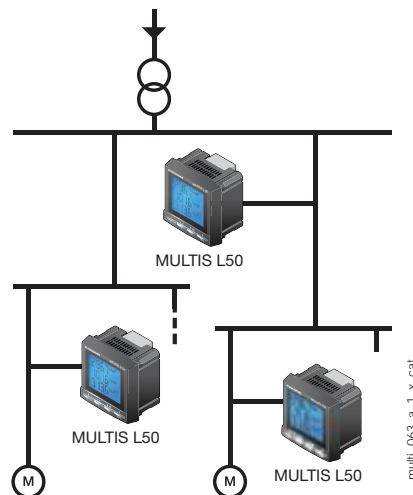

Functions

Multi-measurement

- Currents
 - instantaneous: I1, I2, I3, In
 - maximum average: I1, I2, I3, In
- Voltages & frequency
 - instantaneous: V1, V2, V3, U12, U23, U31, F
- Power
 - instantaneous: 3P, ΣP, 3Q, ΣQ, 3S, ΣS
 - maximum average: ΣP, ΣQ, ΣS
 - unbalance: U unb
- Power factors
 - instantaneous: 3PF, Σ

Metering

- Active energy: ± kWh
- Reactive energy: ± kvarh
- Hours: ⌚

Harmonic analysis

- Total harmonic distortion (level 51)
 - Currents: thd I1, thd I2, thd I3
 - Phase-to-neutral voltage: thd V1, thd V2, thd V3
 - Phase-to-phase voltage: thd U12, thd U23, thd U31

Communications⁽¹⁾

RS485 with MODBUS protocol

Output

- Remote command of device
- Pulse report

Inputs

- Remote status device

(1) Available as an option (see the following pages).

Front panel



1. Backlit LCD display.
2. Direct access key for currents (instantaneous and max. values), current THD.
3. Direct access key for voltages, frequency and voltage THD.
4. Pushbutton for active, reactive, and apparent power (instantaneous and max. values) and power factor.
5. Direct access key for energies, hour meter and programming menu.

Case

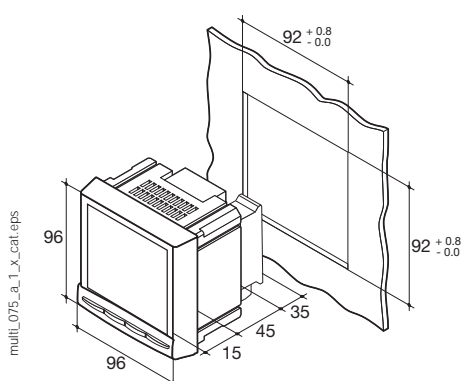

Type	panel mounting
Dimensions W x H x D	96 x 96 x 60 mm
Case degree of protection	IP30
Front degree of protection	IP52
Display type	backlit LCD display
Terminal block type	fixed or plug-in
Voltage and other connection cross-section	0.2 ... 2.5 mm ²
Current connection cross-section	0.5 ... 6 mm ²
Weight	400 g

Plug-in modules

MULTIS L50



1 Output

1 output assignable to:

- Pulses: configurable (type, weight, duration) in kWh or kvarh.
- Remote command of device.



Communication

RS485 link with JBUS / MODBUS protocol (speed up to 38400 bauds)



3 inputs, 1 output

3 inputs assignable to:

- Remote status device.

1 output assignable to:

- Pulses: configurable (type, weight, duration) in kWh or kvarh.
- Remote command of device.

Accessories

Current transformers

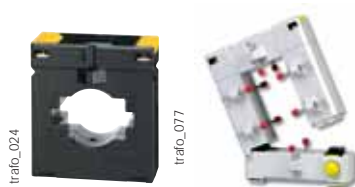

IP65 protection



Panel mounting kit for a 144 x 96 mm cut-out



MULTIS L50

Digital panel meter

three-phases - via CT up to 6000 A dimensions 96 x 96 mm

Electrical characteristics

Current measurement (TRMS)	
Via CT primary	9 999 A
Via CT secondary	5 A
Measurement range	0 ... 11 kA
Input consumption	0.6 VA
Measurement updating period	1 s
Accuracy	1%
Permanent overload	6 A
Intermittent overload	10 I _n for 1 s
Voltage measurements (TRMS)	
Direct measurement between phases	50 ... 500 VAC
Direct measurement between phase and neutral	28 ... 289 VAC
Input consumption	≤ 0.1 VA
Measurement updating period	1 s
Accuracy	1%
Permanent overload	800 VAC
Power measurement	
Measurement updating period	1 s
Accuracy	1%
Power factor measurement	
Measurement updating period	1 s
Accuracy	1%
Frequency measurement	
Measurement range	45 ... 65 Hz
Measurement updating period	1 s
Accuracy	0.1 %

Energy accuracy	
Active (according to IEC 62053-21)	Class 1
Reactive (according to IEC 62053-23)	Class 2
Auxiliary power supply	
Alternating voltage	110 ... 250 VAC
AC tolerance	± 10 %
Direct voltage	120 ... 250 VDC
DC tolerance	± 10%
Frequency	50 / 60 Hz
Consumption	10 VA
Pulse or alarm output	
Number	1
Type	100 VDC - 0.5 A - 10 VA
Max. number of operations	≤ 10 ⁸
Inputs	
Number	3
Power supply	10 ... 30 VDC
Minimum signal width	10 ms
Minimum duration between 2 pulses	18 ms
Type	Phototransistors
Communication	
Link	RS485
Type	2 ... 3 half duplex wires
Protocol	MODBUS RTU
MODBUS® speed	1400 ... 38400 bauds
Operating conditions	
Operating temperature	- 10 ... + 55 °C
Storage temperature	- 20 ... + 85 °C
Relative humidity	95 %

Terminals

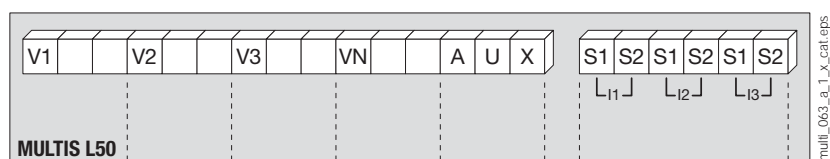

S1 - S2: current inputs.

AUX: auxiliary power supply U_s.
V1, V2, V3 & VN: voltage inputs.

Communication module

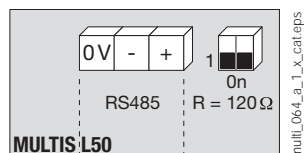

RS485 link.

R = 120 Ω: selectable internal resistance for RS485 end of line termination.

Output or alarm module

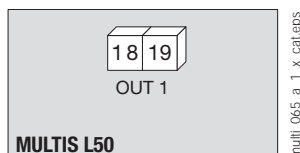

18 - 19: output n°1

3 inputs, 1 output module

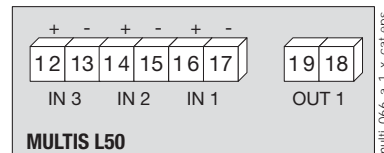

Connection

Recommendation:

- For IT earthing systems, it is recommended that the CT secondary is not connected to earth.
- When disconnecting the DIRIS, the secondary of each current transformer must be short-circuited. This operation can be carried out automatically by a SOCOMEC PTI, an accessory which is included in this catalogue. Please consult us.

Low voltage balanced network

3/4 wires with 1 CT

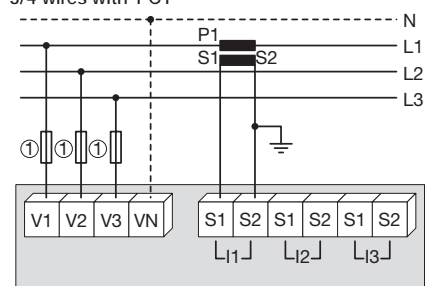

Use of 1 CT reduces by 0.5% the accuracy of the phases, the current of which is worked out by vector calculation.
1. Fuses 0.5 A gG / 0.5 A class CC.

Single-phase

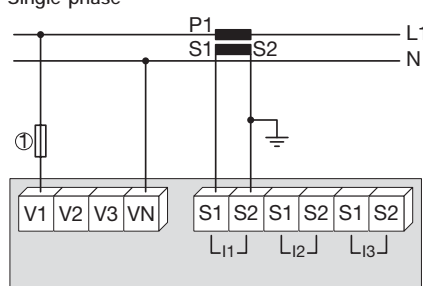

1. Fuses 0.5 A gG / 0.5 A class CC.

Two-phase

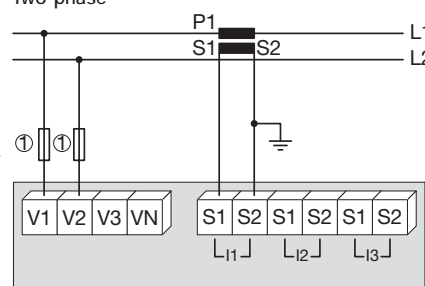

1. Fuses 0.5 A gG / 0.5 A class CC.

Low voltage unbalanced network

3/4 wires with 3 CTs

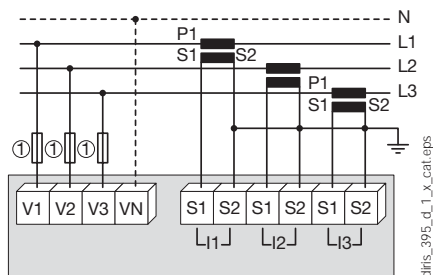

1. Fuses 0.5 A gG / 0.5 A class CC.

3 wires with 2 CTs

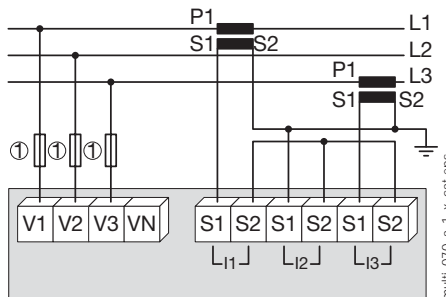

Use of 2 CTs reduces by 0.5% the accuracy of the phases, the current of which is worked out by vector calculation.

1. Fuses 0.5 A gG / 0.5 A class CC.

3 wires with 2 CTs

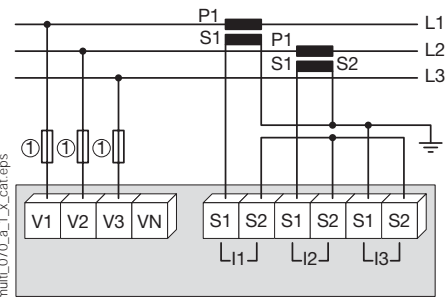

Use of 2 CTs reduces by 0.5% the accuracy of the phases, the current of which is worked out by vector calculation.

1. Fuses 0.5 A gG / 0.5 A class CC.

Additional information

Communication via RS485 link

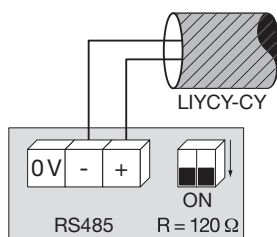

AC & DC auxiliary power supply

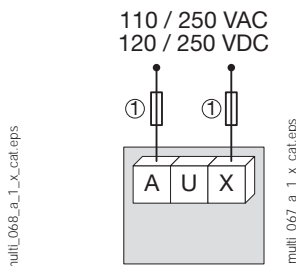

1. Fuses 0.5 A gG / 0.5 A class CC.

References

Basic device		MULTIS L50
MULTIS L50		Reference 192J 9120
Optional plug-in modules		Reference
1 output		4825 0080
RS485 MODBUS® communication		4825 0082
3 inputs, 1 output		4825 0083
Accessories		
Description of accessories	To be ordered in multiples of	Reference
IP65 protection	1	4825 0089
Panel mounting kit for a 144 x 96 mm cut-out	1	4825 0088
Fuse holder for the protection of voltage inputs (type RM) 3 poles	4	5601 0018
Fuse holder for the protection of the auxiliary supply (type RM) 1 pole + neutral	6	5601 0017
Fuse type gG 10x38 0.5 A	10	6012 0000
Ferrite to be associated with communication modules	1	4899 0011
Current transformer range	1	See "TE sensors" pages

Expert Services

> Study, definition, advice, implementation, maintenance and training...
Our experts "Expert Services" offer complete support for the success of your project.



Selection guide



Multifunction meters

DIRIS

Which application?



Which functions?

					
		DIRIS A-10 <i>p. 364</i>	DIRIS A-14 DIN <i>p. 368</i>	DIRIS A-14 96 x 96 <i>p. 368</i>	
		CURRENT TRANSFORMERS			
General characteristics	Functions				
	Remote display				
	Number of loads	1	1	1	
	Mounting	DIN	DIN or 96*96	DIN or 96*96	
	Power supply	AC	AC	AC	
	All In One	•	•	•	
	Optional modules				
	Ethernet (Modbus TCP / Bacnet IP)	o / -	o / -	o / -	
	RS485 (Modbus / Bacnet MSTP)	• / -	• / -	• / -	
	Profibus DPV1				
Webserver / File export	o / -	o / o	o / o		
Max. number of inputs (digital / analogue)	1 / -				
Max. number of outputs (digital / analogue)	1 / -				
Manage energy consumptions	4-quadrant energy metering	•	•	•	
	Load curves (local memory)				
	Rebilling of energy (MID approved)				
	Multi-tariff management	2	4	4	
Monitor the electrical installation	Instantaneous, average, min and max values	•	•	•	
	Voltage unbalance measurement				
	Neutral current (measured / calculated)	- / •	- / •	- / •	
Check the power quality	Harmonic analysis (THD / Individual)	• / -	• / -	• / -	
	Dip and swell detection				
	Overcurrent detection				
	1/2 cycle RMS curves on events				
Manage the loads	Operating hours	•			
	Number of operations (info / alarm)				
	Protective device monitoring (on / off / tripped)	•			
	Predictive power analysis and load shedding				

•: integrated in the product.

o: optional via DIRIS Digiware M-50/M-70 or modules.



Which dimensions?



Which communication protocol?



Which options?

										
DIRIS A-20 <i>p. 372</i>		DIRIS A-30/A-41 <i>p. 376</i>		DIRIS B-10L <i>p. 386</i>		DIRIS B-30 <i>p. 386</i>		DIRIS A-40 Modbus <i>p. 382</i>	DIRIS A-40 Modbus + Profibus <i>p. 382</i>	DIRIS A-40 Modbus + Ethernet <i>p. 382</i>
CURRENT TRANSFORMERS				SMART SENSORS						
1		1		1 to 4		1 to 4		1		
96 x 96		96 x 96		DIN		DIN		96 x 96		
AC		AC/DC		AC		AC		AC/DC		
•		•		•		•		•		
0/-		0/-		•/0		•/0		-/-	-/-	•/•
•/-		•/-		•/0		•/0		•/-	•/-	•/-
0		0		0		0		-	•	-
0/0		Via DIRIS G		0/0		0/0		0/0	0/0	•/•
3/-		6/4		2/2		2/2		3/-		
1/-		6/4		2/2		2/2		2/-		
•		•		•		•		•		
		0		•		•		•		
				8		8		4		
•		•		•		•		•		
•		•		•		•		•		
-/•		• (with A-41)		•/•		•/•		-/•		
•/-		•/•		•/-		•/•		•/•		
				•		•		•		
				•		•		•		
•		•		•		•		•		
•/-		•/-		•/-		•/•		•/•		
•		•		•		•		•		
				•		•		•		

DIRIS A-10

Multifunction meters - PMD

measuring and monitoring - modular format



DIRIS A-10

diris_978_front.psd

Function

The DIRIS A-10 is a modular multifunction meter for measuring electrical values in low voltage networks with connection to current transformers.

It allows all electrical parameters to be displayed and utilised for communication and/or output functions.

Advantages

Easy to use

Five direct access pushbuttons enable all measurements to be clearly viewed on its backlit LCD display.

Integrated temperature sensor

It allows variations in temperature to be detected.

Detects wiring errors

An integrated test function can be utilised to detect incorrect wiring and to automatically correct CT installation errors.

Compliant with IEC 61557-12

IEC 61557-12 is a high-level standard for all PMDs (Performance Monitoring Devices) that are designed to measure and monitor electrical parameters in distribution networks. Compliance with IEC 61557-12 ensures a high level of equipment performance, in terms of metrology, and the mechanical and environmental aspects (EMC, temperature, etc.).

Principle diagram

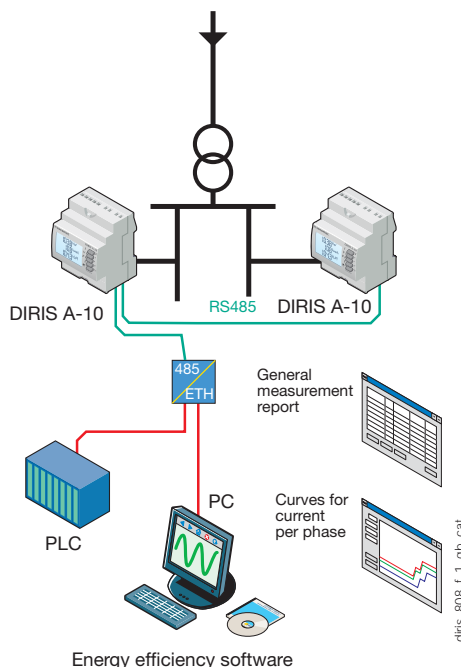

diris_808_L1_ghb_cat

The solution for

- > Industry
- > Infrastructures
- > Tertiary



Strong points

- > Easy to use
- > Integrated temperature sensor
- > Detects wiring errors
- > Compliant with IEC 61557-12

Conformity to standards

- > IEC 61557-12
- > IEC 62053-22 class 0.5S
- > IEC 62053-23 class 2
- > UL



Associated with current transformers



See "Current transformers".

Functions

Multi-measurement

- Currents
 - instantaneous: I1, I2, I3, In
 - maximum average: I1, I2, I3, In
- Voltages & frequency
 - instantaneous: V1, V2, V3, U12, U23, U31, F
- Power
 - instantaneous: 3P, ΣP, 3Q, ΣQ, 3S, ΣS
 - maximum average: ΣP, ΣQ, ΣS
- Power factors
 - instantaneous: 3PF, ΣPF

Metering

- Active energy: +/- kWh
- Reactive energy: +/- kVarh
- Hours: ⌚

Harmonic analysis

- Total harmonic distortion (level 51)
 - Currents: thd I1, thd I2, thd I3
 - Phase-to-neutral voltage: thd V1, thd V2, thd V3
 - Phase-to-phase voltage: thd U12, thd U23, thd U31

Dual tariff function

Selection of one out of 2 billing tariffs

Events

Alarms on all electrical values

Communications⁽¹⁾

RS485 with MODBUS protocol

Input

- Tariff selection
- Remote device status

Output

- Remote command of device
- Alarm report
- Pulse report

⁽¹⁾ Available on specific version (see the following pages).

Front panel

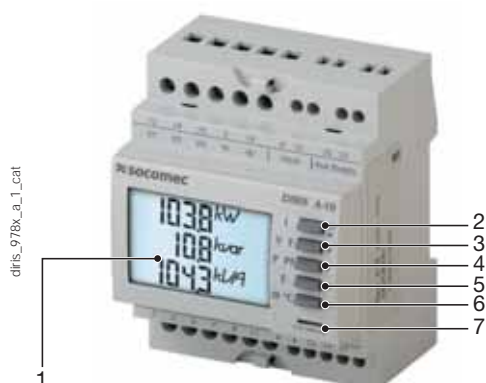

Case

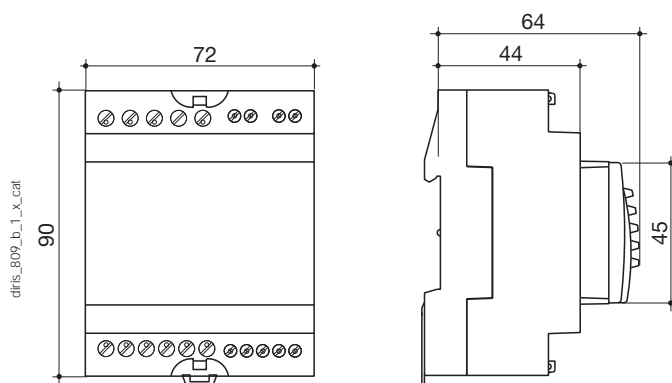

Type	modular
Number of modules	4
Dimensions W x H x D	72 x 90 x 64 mm
Case degree of protection	IP 30
Front degree of protection	IP 52
Display type	backlit LCD display
Voltage and current connection cross-section	4 mm ²
Connection cross-section for AUX supply, input, output and comms.	2.5 mm ²
Weight	205 g (4825 0010) - 215 g (4825 0011)

Electrical characteristics

Current measurement (TRMS)	
Via CT primary	9 999 A
Via CT secondary	5 A
Measurement range	0 ... 11 kA
Input consumption	0.6 VA
Measurement updating period	1 s
Accuracy	0.2 %
Permanent overload	6 A
Intermittent overload	10 I _n for 1 s
Voltage measurements (TRMS)	
Direct measurement between phases	50 ... 500 VAC
Direct measurement between phase and neutral	28 ... 289 VAC
Input consumption	≤ 0.1 VA
Measurement updating period	1 s
Accuracy	0.2 %
Power measurement	
Measurement updating period	1 s
Accuracy	0.5 %
Power factor measurement	
Measurement updating period	1 s
Accuracy	0.5 %
Frequency measurement	
Measurement range	45 ... 65 Hz
Measurement updating period	1 s
Accuracy	0.1 %

Energy accuracy	
Active (according to IEC 62053-22)	Class 0.5 S
Reactive (according to IEC 62053-23)	Class 2
Auxiliary power supply	
Alternating voltage	110 ... 277 VAC
AC tolerance	± 15 %
Frequency	50 / 60 Hz
Consumption	< 3 VA
Digital output (pulses)	
Number	1
Optocoupler type (IEC 62053-31)	Class A and B (10 ... 30 VDC, 27mA)
Input (tariff)	
Number	1
Type	0 VAC: T1 / 200-277 VAC: T2
Communication	
Link	RS485
Type	2 ... 3 half duplex wires
Protocol	MODBUS RTU
MODBUS® speed	2400 ... 38400 bauds
Operating conditions	
Operating temperature	- 10 ... + 55 °C
Storage temperature	- 20 ... + 70 °C
Relative humidity	85 %

DIRIS A-10

Multifunction meters - PMD

measuring and monitoring - modular format

Connection

Recommendation:

- For IT earthing systems, it is recommended that the CT secondary is not connected to earth.
- When disconnecting the DIRIS, the secondary of each current transformer must be short-circuited. This operation can be carried out automatically by a SOCOMEC PTI, an accessory which is included in this catalogue. Please consult us.
- It is recommended that the earthing point for the DIRIS A-10 and the current transformer secondaries are not earthed at the same time.

Low voltage balanced network

3/4 wires with 1 CT

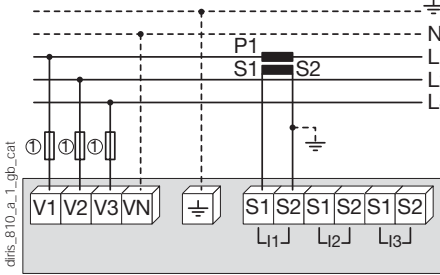

1. Fuses 0.5 A gG / 0.5 A class CC.

Single-phase

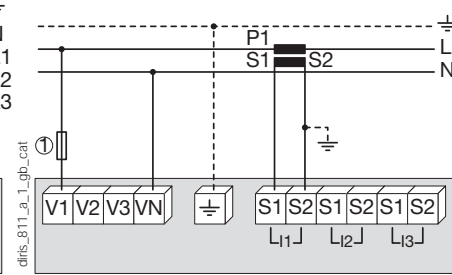

1. Fuses 0.5 A gG / 0.5 A class CC.

Two-phase

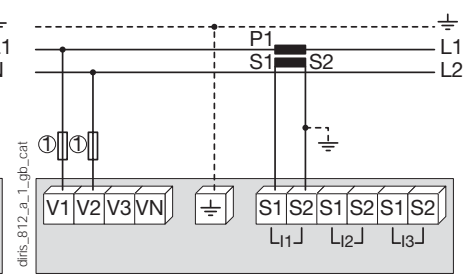

1. Fuses 0.5 A gG / 0.5 A class CC.

Low voltage unbalanced network

3/4 wires with 3 CTs

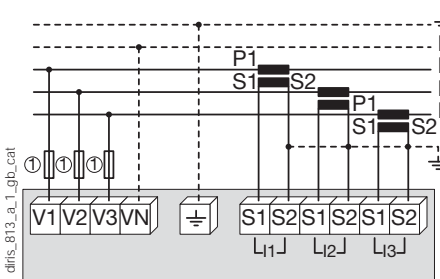

1. Fuses 0.5 A gG / 0.5 A class CC.

3 wires with 2 CTs

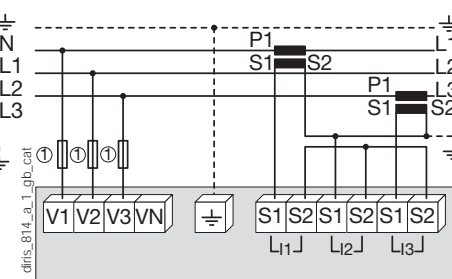

Use of 2 CTs reduces by 0.5% the accuracy of the phases, the current of which is worked out by vector calculation.

1. Fuses 0.5 A gG / 0.5 A class CC.

3 wires with 2 CTs

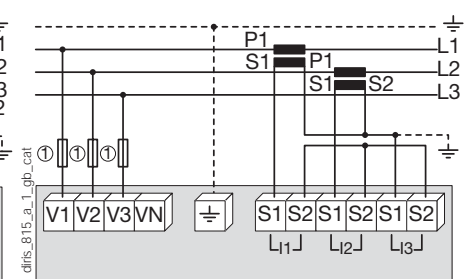

Use of 2 CTs reduces by 0.5% the accuracy of the phases, the current of which is worked out by vector calculation.

1. Fuses 0.5 A gG / 0.5 A class CC.

Additional information

Communication via RS485 link

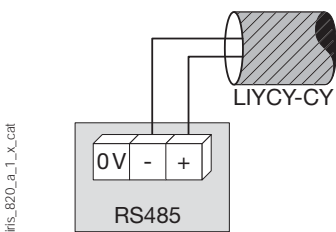

AC auxiliary power supply

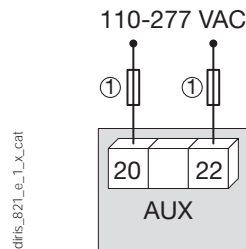

1. Fuses 0.5 A gG / 0.5 A class CC.

Terminals

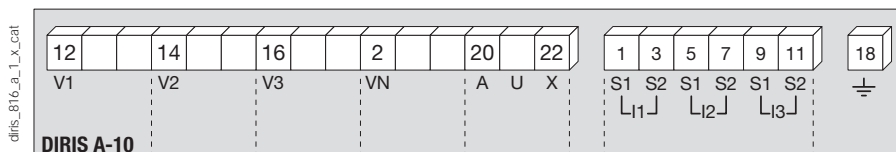

AUX: auxiliary power supply U_s .
V1, V2, V3 & VN: voltage inputs.

S1 - S2: current inputs.

Communication terminals

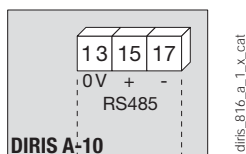

RS485 link.

Pulse or alarm output terminals

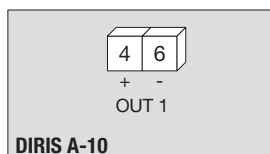

4 - 6: output n°1

Input terminals

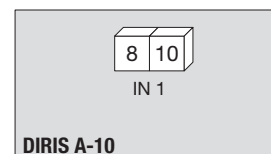

8 - 10: input n°1

References

Basic device	DIRIS A-10	
Description	Reference	
DIRIS A-10	4825 0400	
DIRIS A-10 with RS485 MODBUS communication	4825 0401	
Accessories	To be ordered in multiples of	Reference
Fuse disconnect switches for the protection of voltage inputs (type RM) 3 poles	4	5701 0018
Fuse disconnect switches for the protection of the auxiliary supply (type RM) 1 pole + neutral	6	5701 0017
Fuses type gG 10x38 0.5 A	10	6012 0000
Current transformer range	1	See "Current transformers" pages
Management software for DIRIS	See "Easy Config System" pages	
Door mounting kit	4825 0088	
Automatic CT short-circuiting device	See "Current transformers" pages	

Expert Services

- > Study, definition, advice, implementation, maintenance and training... Our experts "Expert Services" offer complete support for the success of your project.



DIRIS A14

PMD - MID multifunction measuring unit
measuring and monitoring - modular format



DIRIS A14 panel mounted



DIRIS A14 DIN rail mounted

The solution for

- > Industry
- > Infrastructures
- > Data centers



Strong points

- > Single-phase and three-phases MID certified
- > Bi-directional metering
- > Multi-measurement and load curves
- > IEC 61557-12 measuring method
- > Detection of connection errors

Compliance with standards

- > IEC 61557-12
- > IEC 62053-23 class 2
- > EN50470-1
- > EN50470-3 class C



Associated with current transformers



See "Current transformers".

Function

The DIRIS A14 is an MID approved multifunction meter - for measuring electrical values in low voltage networks. It allows all electrical parameters to be displayed and utilised for communication and/or output functions.

Advantages

Single-phase and three-phases MID certified

DIRIS A14 products with MID certification provide the guaranteed accuracy required for applications in which sub-billing of the electrical energy consumed is necessary, whether on a three-phase or single-phase network. "Module B+D" certification guarantees that the design and manufacturing process of products are approved by an accredited laboratory.

Bi-directional metering (four quadrants)

This function is for metering energy production or energy consumption.

Multi-measurement and load curve

Display of electrical values (I, U, V, ΣP , ΣQ , ΣS , PF) and P+ load curve over a 7 day period via communication.

IEC 61557-12 measuring method

IEC 61557-12 is a high-level standard covering all PMDs (Performance Monitoring Devices). By using the measuring method of IEC 61557-12 ensures a high level of equipment performance, in terms of metrology.

Functional diagram

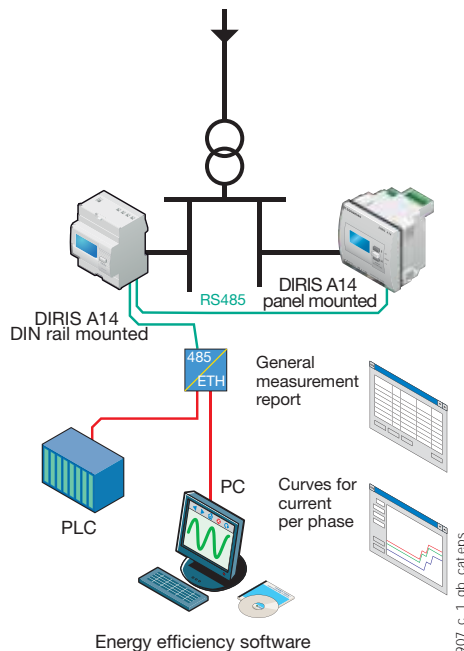

Detection of connection errors

The product is protected against phase/neutral inversion and detects wiring errors. The power supply internally derived from the voltage connections ensures realtime MID counting as soon as the mains voltage is present.

Functions

Multi-measurement

- Currents
 - instantaneous: I1, I2, I3, In
 - maximum average: I1, I2, I3, In
- Frequency
- Voltages
 - instantaneous: V1, V2, V3, U12, U23, U31, F
- Powers
 - instantaneous: ΣP , ΣQ , ΣS
 - maximum average: ΣP , ΣQ , ΣS
- Power factor ($\cos \phi$)
 - instantaneous: $\Sigma \cos \phi$
 - maximum average: $\Sigma \cos \phi$

Total and partial metering

- Active energy: + kWh, - kWh
- Reactive energy: + kvarh, - kvarh

Harmonic analysis (via communication)

- Total harmonic distortion (rank 63)
 - Currents: thd I1, thd I2, thd I3
 - Phase-to-neutral voltage: thd V1, thd V2, thd V3
 - Phase-to-phase voltage: thd U12, thd U23, thd U31

Multi tariff function (via communication)

- Selection of one out of 4 billing tariffs

Events (via communication)

- Active energy consumption: day n-1 / week n-1 / month n-1
- Active power load curves: P 10 minutes over 7 days with time-log

Communications

- RS485 with MODBUS protocol

Front panel

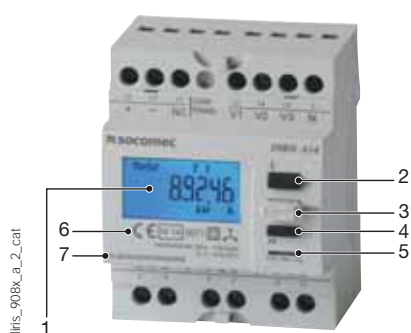

1. Backlit LCD display
2. Direct access for energies and validation key
3. Programming key
4. Navigation key for measurements
5. Metrological LED
6. MID marking
7. Serial Number



Case

DIRIS A14 DIN rail mounted

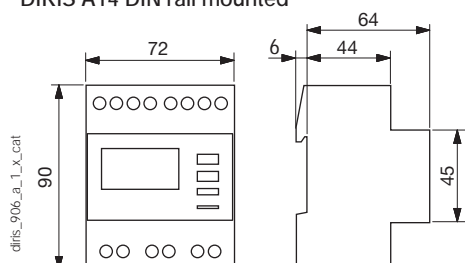

DIRIS A14 door mounted

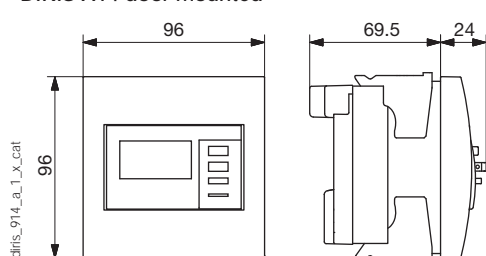

	DIRIS A14 DIN rail mounted	DIRIS A14 door mounted
Type	modular	Recessed
Number of modules	4	-
Dimensions W x H x D	72 x 90 x 64 mm	96 x 96 x 69.5 mm
Case degree of protection		IP20
Front degree of protection		IP51
Display type		Backlit LCD
Rigid cable cross-section		1.5 ... 10 mm ²
Flexible cable cross-section		1 ... 6 mm ²
Weight	240 g	450 g

Electrical characteristics

Current measurement (TRMS)	
Via CT primary	10 ... 2500 A
Via CT secondary	5 A
Input consumption	0.6 VA
Startup current (Ist)	5 mA
Minimum current (Imin)	50 mA
Transmission current (Itr)	250 mA
Reference current (Iref)	5 A
Measurement updating period	1 s
Accuracy	0.5%
Permanent overload	6 A
Intermittent overload	120 A for 0.5 s
Voltage measurements (TRMS)	
Direct measurement (four phases)	50 ... 460 VAC
Input consumption	2 VA
Measurement updating period	1 s
Accuracy	0.2%
Permanent overload	480 V (phase-to-phase measurement)
Power measurement	
Measurement updating period	1 s
Accuracy	0.5%
Power factor measurement (cos φ)	
Measurement updating period	1 s
Accuracy	0.01

Energy accuracy	
Active (according to IEC 62053-22)	Class 0.5 S
Reactive (according to IEC 62053-23)	Class 2
Active (according to EN 50470)	Class C
Metrological LED (EA*, EA*)	
Pulse weight	10000 pulses/kWh
Colour	Red
Auxiliary power supply	
Self-powered	Yes
Frequency	50 / 60 Hz
Communication	
Link	RS485
Type	2 to 3 half duplex wires
Protocol	MODBUS® RTU
MODBUS® speed	4800 ... 38400 bauds
Operating conditions	
Operating temperature	-10 ... +55°C
Storage temperature	-20 ... +70°C
Relative humidity	95% non-condensing

DIRIS A14

PMD - MID multifunction measuring unit
measuring and monitoring - modular format

Connection

Low voltage balanced network

Recommendation:

- For IT earthing systems, it is recommended that the CT secondary is not connected to earth.
 - When disconnecting the DIRIS, the secondary of each current transformer must be short-circuited.
- This operation can be carried out automatically by a SOCOMEC PTI, which can be found in the SOCOMEC catalogue: please consult us.

Low voltage unbalanced network

3/4 wires with 3 CTs

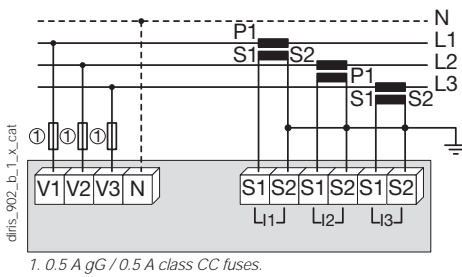

Single-phase

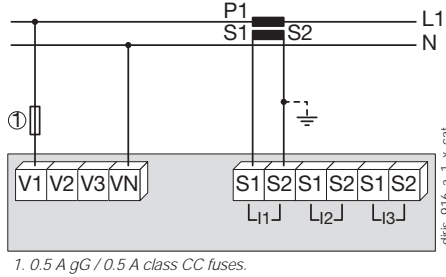

3 wires with 2 CTs

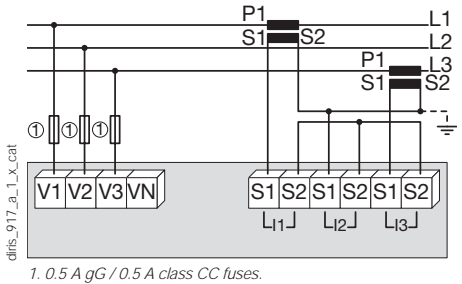

3 wires with 2 CTs

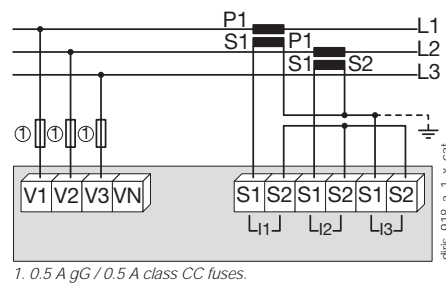

Additional information

Communication via RS485 link

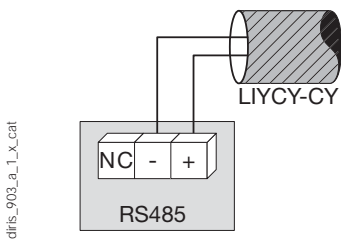

Terminals

Communication Module

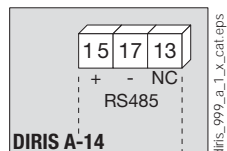

RS485 link.

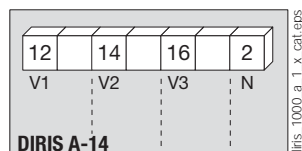

V1, V2, V3 & N: voltage inputs.

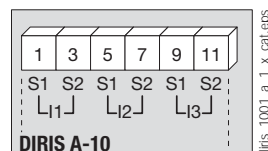

S1 - S2: current inputs.

References

Basic device		DIRIS A14 Reference
Description		
DIRIS A14 MID DIN rail mounted		4825 0020
DIRIS A14 MID door mounted		4825 0021
Accessories		Reference
	To be ordered in multiples of	
Fuse disconnect switches for the protection of voltage inputs (type RM)	4	5701 0018
Fuse disconnect switches to protect the 1-pole + neutral auxiliary power supply (RM type)	6	5701 0017
gG 10x38 0,5 A fuses type	10	6012 0000
Automatic CT short-circuiting device	See "Current transformers" pages	

Expert Services

- > Study, definition, advice, implementation, maintenance and training... Our experts "Expert Services" offer complete support for the success of your project.



DIRIS A-20

Multifunction measuring unit - PMD
measurement and monitoring - door mounting



DIRIS A-20

diris_981_front.eps

The solution for

- > Industry
- > Infrastructure
- > Building



Strong points

- > User-friendly operation
- > Compliant with IEC 61557-12
- > Detects wiring errors
- > Customisable

Compliance with standards

- > IEC 61557-12
- > IEC 62053-22 class 0.5S
- > IEC 62053-23 class 2
- > UL



Related software

- > To use Socomec PMDs effectively, we can offer you several dedicated software tools. See "Easy Config System" pages.

Function

DIRIS A-20 units are performance metering and monitoring devices that provide the user with all of the measurements needed to complete energy efficient projects successfully and to provide assured monitoring of electrical distribution.

All of this information can be used and analysed remotely with the help of energy efficiency software programs.

Advantages

User-friendly operation

With its large backlit multiple-display screen with 4 hot keys, the DIRIS A-20 is easy to use.

Compliant with IEC 61557-12

Reference standard for PMDs (Performance metering & monitoring devices), IEC 61557-12 guarantees performance levels and satisfactory performance from the PMDs under the environmental conditions typical of industrial and tertiary applications.

Detects wiring errors

The DIRIS A-20 is equipped with an error correction function for CT connection.

Customisable

Additional communication and input/output modules can extend the basic functional scope of this product. Equipped with additional modules, the DIRIS A-20 can provide the user with flexibility and expandability throughout the service life of the product.

Functional diagram

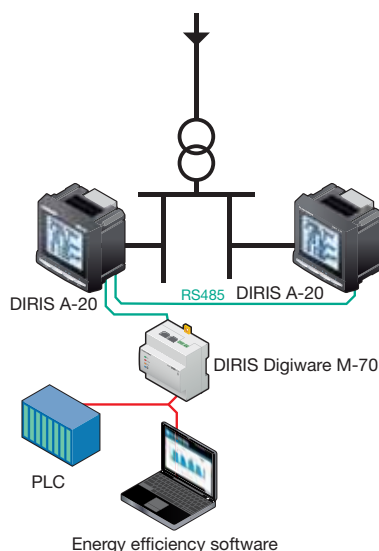

DIRIS_576_L1_en_cat

Functions

Multi-measurement

- Currents
 - instantaneous: I1, I2, I3, In
 - maximum average: I1, I2, I3, In
- Voltages & frequency
 - instantaneous: V1, V2, V3, U12, U23, U31, F
- Powers
 - instantaneous: 3P, ΣP, 3Q, ΣQ, 3S, ΣS
 - maximum average: ΣP, ΣQ, ΣS
- Power factors
 - instantaneous: 3PF, ΣPF

Metering

- Active energy: +/- kWh
- Reactive energy: +/- kvarh
- Hours: ⌚

Harmonic analysis

- Total harmonic distortion (rank 51)
 - Currents: thd I1, thd I2, thd I3
 - Phase-to-neutral voltage: thd V1, thd V2, thd V3
 - Phase-to-phase voltage: thd U12, thd U23, thd U31

Events

Alarms on all electrical parameters

Communications⁽¹⁾

RS485 with MODBUS protocol

Output

- Equipment control
- Alarm report
- Pulse report

Input

- Information report from a dry external contact

(1) Available as an option (see the following pages).

Front panel



1. Backlit LCD display
2. Pushbutton for currents (instantaneous and maximum), THD currents and the connection correction function.
3. Pushbutton for voltages, frequency and THD voltages.
4. Pushbutton for power (instantaneous and maximum), active, reactive and effective, power factor.
5. Pushbutton for energy sources and timer counter.

Case

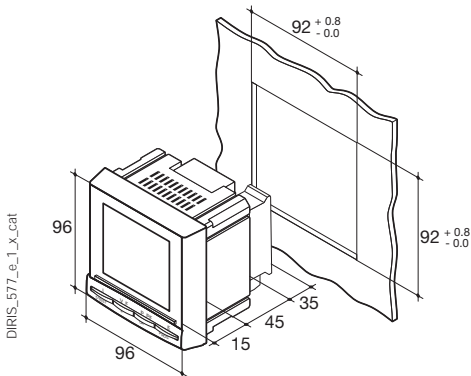

Type	Plug-in
Dimensions W x H x D	96 x 96 x 60 mm
Case degree of protection	IP30
Front degree of protection	IP52
Display type	Backlit LCD
Type of terminal strips	Fixed or removable
Section for connection of voltages and other terminals	0.2 ... 2.5 mm ²
Section for connection of currents	0.5 ... 6 mm ²
Weight	400 g

Plug-in optional modules

DIRIS® A-20



1 output

- 1 output that can be configured for:
- pulses: configurable (type, weight, duration) to kWh or kVarh.
 - Monitoring: 3I, In, 3V, 3U, F, ΣP, ΣQ, ΣS, ΣPFL/C, THD 3I, THD 3V, THD 3U and timer meter.
 - Equipment control



Communication

RS485 link with MODBUS protocol (speed up to 38 400 baud).



3 inputs , 1 output

- 3 inputs can be configured into:
- Information report from an external contact.
- 1 output that can be configured for:
- pulses: configurable (type, weight, duration) to kWh or kVarh.
 - Monitoring: 3I, In, 3V, 3U, F, ΣP, ΣQ, ΣS, ΣPFL/C, THD 3I, THD 3V, THD 3U and timer meter.
 - Equipment control

Accessories

Current transformer

See "Current transformers" pages.

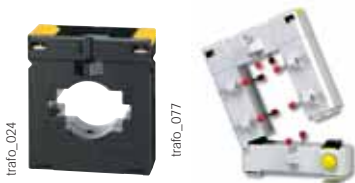

IP65 protection



DIRIS A-20

Multifunction measuring unit - PMD

measurement and monitoring - door mounting

Electrical characteristics

Current measurement (TRMS)	
Via CT primary	9 999 A
Via CT secondary	5 A
Measurement range	0 ... 11 kA
Input consumption	0.6 VA
Measurement updating period	1 s
Accuracy	0.2%
Permanent overload	6 A
Intermittent overload	10 I _n over 1 sec
Voltage measurements (TRMS)	
Direct measurement between phases	50 ... 500 VAC
Direct measurement between phase and neutral	28 ... 289 VAC
Input consumption	≤ 0.1 VA
Measurement updating period	1 s
Accuracy	0.2%
Power measurement	
Measurement updating period	1 s
Accuracy	0.5%
Power factor measurement	
Measurement updating period	1 s
Accuracy	0.5%
Frequency measurement	
Measurement range	45 ... 65 Hz
Measurement updating period	1 s
Accuracy	0.1%

Energy accuracy	
Active (according to IEC 62053-22)	Class 0.5 S
Reactive (in acc. with CEI 62053-23)	Class 2
Auxiliary power supply	
Alternative voltage	110 ... 400 VAC
AC tolerance	± 10%
DC voltage	120 ... 289 VDC
DC tolerance	± 20%
Frequency	50 / 60 Hz
Power consumption	10 VA
Pulse or alarm output	
Number	1
Type	100 VDC - 0,5 A - 10 VA
Max. number of manoeuvres	≤ 10 ⁸
Inputs	
Number	3
Power supply	10 ... 30 VDC
Minimum width of signal	10 ms
Minimum length between 2 pulses	18 ms
Type	Optical couplers
Communication	
Link	RS485
Type	2 to 3 half duplex wires
Protocol	MODBUS® in RTU mode
MODBUS® speed	1400 ... 38400 baud
Operating conditions	
Operating temperature range	- 10 ... + 55°C
Storage temperature	- 20 ... + 85°C
Relative humidity	95%

Terminals

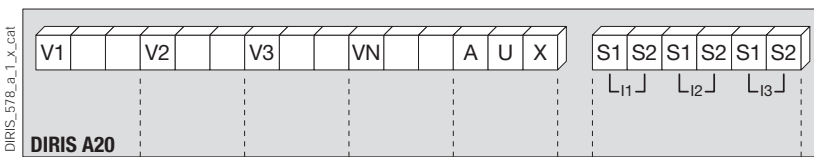

S1 - S2: current inputs.

AUX: auxiliary power supply U_s.
V1, V2, V3 & VN: voltage inputs.

Module communication

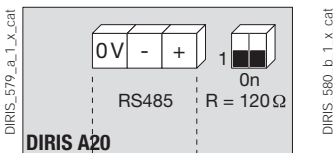

RS485 link.
R = 120 Ω: internal resistance for the RS485 link.

Output or alarm module

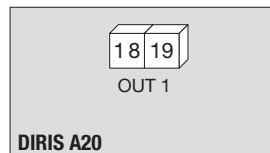

18 - 19: output n°1

Module with 3 inputs, 1 output

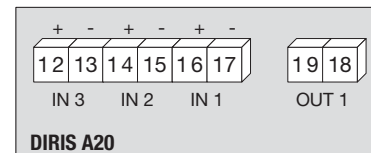

Connection

Low voltage balanced network

Recommendation

- For IT earthing systems, it is recommended that the CT secondary is not connected to earth.
- When disconnecting the DIRIS, the secondary of each current transformer must be short-circuited. This operation can be carried out automatically by a SOCOMEC PTI, which can be found in the SOCOMEC catalogue: please consult us.

3/4 wires with 1 CT

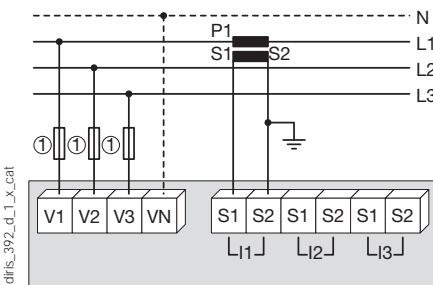

The 1CT solution reduces by 0.5% the accuracy of the phase for which the current is deduced by a vector calculation.
1. 0.5 A gG / 0.5 A class CC fuses.

Single-phase

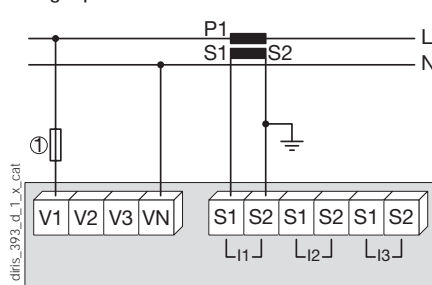

1. 0.5 A gG / 0.5 A class CC fuses.

Two-phase

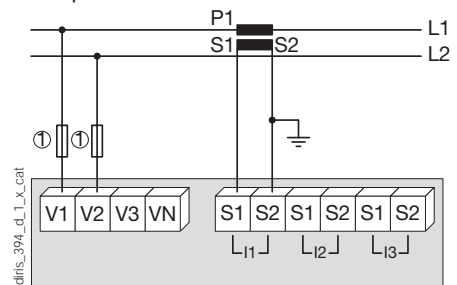

1. 0.5 A gG / 0.5 A class CC fuses.

Low voltage unbalanced network

3/4 wires with 3 CTs

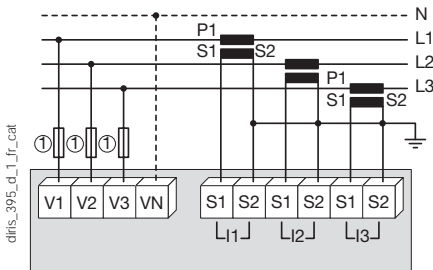

1. 0.5 A gG / 0.5 A class CC fuses.

3 wires with 2 CTs

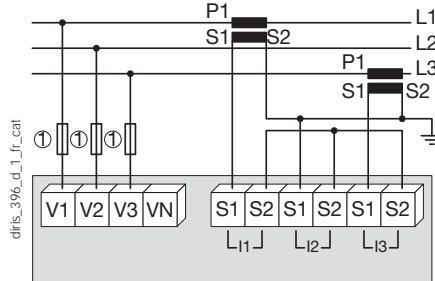

The 2CT solution reduces by 0.5% the accuracy of the phase for which the current is deduced by a vector calculation.
1. 0.5 A gG / 0.5 A class CC fuses.

3 wires with 2 CTs

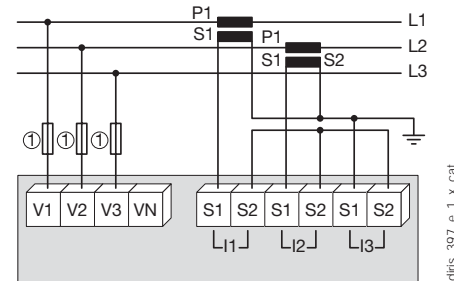

The 2CT solution reduces by 0.5% the accuracy of the phase for which the current is deduced by a vector calculation.
1. 0.5 A gG / 0.5 A class CC fuses.

Additional information

Communication via RS485 link

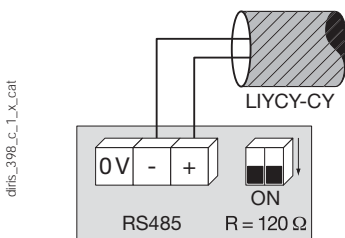

AC and DC auxiliary power supply

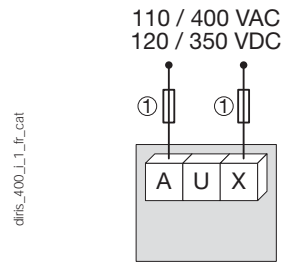

1. 0.5 A gG / 0.5 A class CC fuses.

References

Basic device		DIRIS A-20
Auxiliary power supply U_s		Reference
110 ... 400 VAC / 120 ... 350 VDC		4825 0402
Options		
Plug-in modules		Reference
On/Off output.		4825 0080
RS485 MODBUS® communication		4825 0082
3 inputs, 1 output		4825 0083
Accessoires	To be ordered in multiples of	Reference
Protection IP65	1	4825 0089
Plug-in kit for cutout 144 x 96 mm	1	4825 0088
3-pole fuse disconnect switches to protect input voltages (RM type)	4	5601 0018
1-pole + neutral fuse disconnect switches to protect the auxiliary supply (RM type)	6	5601 0017
gG 10x38 0.5 A fuses	10	6012 0000
Ferrite for use with communication modules	1	4899 0011
Current transformer range	1	See "Current transformers" pages
Software associated with DIRIS		See "Easy Config System" pages
Automatic CT short-circuiting device		See "Current transformers" pages

Expert Services

> Study, definition, advice, implementation, maintenance and training...
Our experts "Expert Services" offer complete support for the success of your project.



DIRIS A-30/A-41

Multifunction measuring unit - PMD
measurement and advanced monitoring - door mounting



DIRIS A-30

The solution for

- > Industry
- > Building
- > Infrastructures



Strong points

- > User-friendly operation
- > Detects wiring errors
- > Customisable
- > Compliant with IEC 61557-12

Compliance with standards

- > IEC 61557-12
- > IEC 62053-22 class 0.5 S
- > IEC 62053-23 class 2
- > UL



Function

The DIRIS A-30 and A-41 are power monitoring devices that provide the user with all of the measurements needed to complete energy efficiency projects and to assure the monitoring of electrical distribution.

All the information can be used and analysed remotely using energy efficiency software packages.

Advantages

User-friendly operation

With its large backlit multiple-display screen with 6 hot keys, the DIRIS A-30 is easy to use.

Detects wiring errors

The DIRIS A-30 is provided with a correction function for TC wiring errors.

Customisable

The DIRIS A-30 can be equipped with additional modules that give the user flexibility throughout the service life of the product. Communication modules and additional digital or analogue inputs/outputs can be used to increase its range of functionality.

Functional diagram

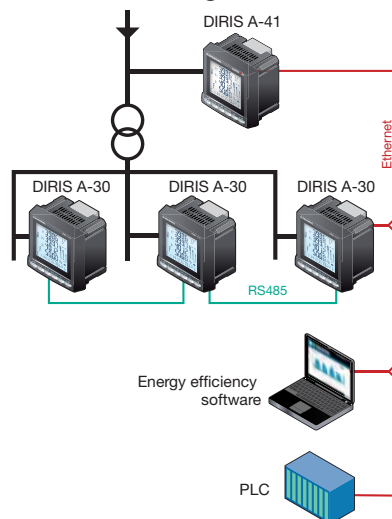

Compliant with IEC 61557-12

Reference standard for PMDs (Performance metering & monitoring devices), IEC 61557-12 guarantees performance levels and satisfactory performance from the PMDs under the environmental conditions typical of industrial and tertiary applications.

Functions

Multi-measurement

- Currents
 - instantaneous: I1, I2, I3, In, Isystem
 - average/max average: I1, I2, I3, In
- Voltages & frequency
 - instantaneous: V1, V2, V3, U12, U23, U31, F, Vsystem, Usystem
 - average/max average: V1, V2, V3, U12, U23, U31, F
- Powers
 - instantaneous: 3P, ΣP, 3Q, ΣQ, 3S, ΣS
 - max average: ΣP, ΣQ, ΣS
 - predictive: (ΣP), (ΣQ), (ΣS)
- Power factors
 - instantaneous: 3PF, ΣPF
 - average/max average: ΣPF

- Kfactor
- Temperatures⁽¹⁾
 - internal
 - external via 3 PT100 probes

Metering

- Active energy: +/- kWh
- Reactive energy: +/- kvarh
- Effective power: kVAh
- Hours: ⌚

Harmonic analysis

- Level of harmonic distortion
- Currents: thd I1, thd I2, thd I3, thd In
- Phase-to-neutral voltage: thd V1, thd V2, thd V3
- Phase-to-phase voltage: thd U12, thd U23, thd U31

Individual harmonics up to 63rd

- Currents: HI1, HI2, HI3, HIn
- Phase-to-neutral voltage: HV1, HV2, HV3,
- Phase-to-phase voltages: HU12, HU23, HU31

Load curve⁽¹⁾

- Active & reactive power: ΣP+/-; ΣQ+/-
- Voltages & frequency: V1, V2, V3, U12, U23, U31, F

Events⁽¹⁾

- Alarms on all electrical parameters.

Communications⁽¹⁾

- RS485 (Modbus)
- Ethernet (Modbus/TCP or Modbus RTU)
- Ethernet with RS485 Modbus RTU gateway over TCP
- Profibus DP Sub-D9

Inputs/Outputs⁽¹⁾

- Pulse counting
- Checking / control of equipment
- Alarm report
- Pulse report

Analogue output

- Analogue 0/4- 20 mA
- ⁽¹⁾ Available as an option (see following pages).

Front panel



1. Backlit LCD display
2. Pushbutton for currents and for connection correction function
3. Pushbutton for voltages and frequency.
4. Pushbutton for active, reactive and effective powers and for power factor.
5. Pushbutton for maximum and average values for currents and power levels.
6. Pushbutton for harmonics.
7. Pushbutton for electrical energy meters, timers and impulse counters

Plug-in modules

DIRIS® A-30



dfis_773_a

DIRIS® A-41*



dfis_774_a

* With current measurement module for Neutral as standard.



Pulse outputs

2 configurable pulse outputs (type, weight and run) on \pm kWh, \pm kvarh and kVAh.



MODBUS® communication

RS485 link with MODBUS® protocol (speed up to 38400 baud).



PROFIBUS® DP communication

SUB-D9 link with PROFIBUS® DP protocol (speed up to 12 Mbaud).



Analogue outputs

You can connect a maximum of 2 modules, i.e. 4 analogue outputs.
2 outputs can be allocated to:
3I, In, 3V, 3U, F, \pm Σ P, \pm Σ Q, Σ S, Σ PFL/C, Isys, Vsys, Usys, Ppred, Qpred, Spred, T°C internal, T°C 1, T°C 2, T°C3 and to 30 VDC power supply.



2 inputs - 2 outputs

You can connect a maximum of 3 modules, i.e. 6 inputs / 6 outputs.
2 outputs can be allocated to:
- monitoring: 3I, In, 3V, 3U, F, \pm Σ P, \pm Σ Q, Σ S, Σ PFL/C, THD 3I, THD In, THD 3V, THD 3U, Ppred, Qpred, Spred, T°C internal, T°C 1, T°C2, T°C3 and of time counter,
- remote control,
- timed remote control,
- 2 inputs for pulse counting.



Storage capability

- Memory function up to max. 62 days for P+, P-, Q+, Q- with a TOP for internal or external synchronisation of 5, 8, 10, 15, 20, 30 and 60 minutes.
- Memory function for the last 10 timed and dated alarms.
- Memory function for the last min and max instantaneous values for 3U, 3V, 3I, In, F, Σ P \pm , Σ Q \pm , Σ S, THD 3U, THD 3V, THD, 3U, THD, 3V, THD, 3I, THD In.
- Memory function of average values 3U, 3V et F as a function of synchronisation (maximum 60 days).



Ethernet communication

- Ethernet link with MODBUS/TCP or MODBUS RTU over TCP.



Ethernet communication with RS485 MODBUS gateway

- Ethernet link with MODBUS/TCP or MODBUS RTU over TCP.
- Connect 1 to 247 RS485 MODBUS slaves.

DIRIS A-30/A-41

Multifunction measuring unit - PMD

measurement and advanced monitoring - door mounting

Accessories

Current transformer

See "Current transformers" pages.

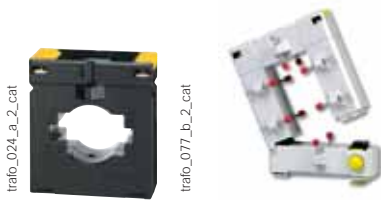

IP65 protection



Terminals

DIRIS A-30

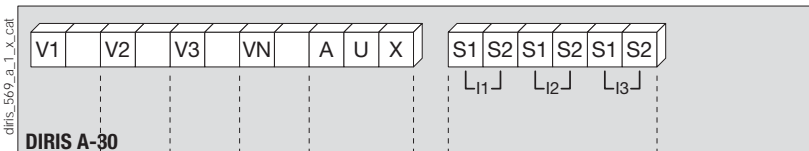

S1 - S2: current inputs

AUX: auxiliary power supplies U_s
V1 - V2 - V3 - VN: voltage inputs

DIRIS A-41

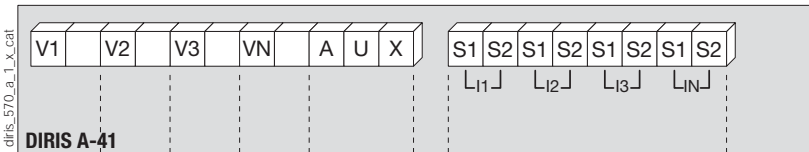

S1 - S2: current inputs

AUX: auxiliary power supplies U_s
V1 - V2 - V3 - VN: voltage inputs

Communication module

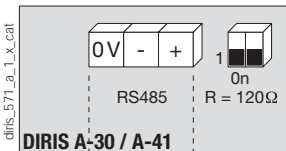

RS485 link.

R = 120 Ω : internal resistance for the RS485 link.

Pulse output module

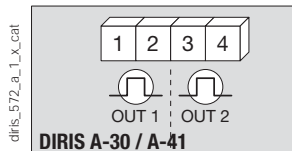

1 - 2: pulse output n°1.

3 - 4: relay output n°2.

Analogue output module

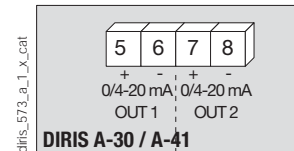

5 - 6: analogue output n°1.

7 - 8: analogue output n°2.

2 input / 2 output module

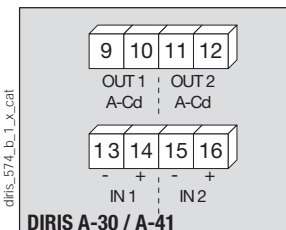

9 - 10: relay output n°1.

11 - 12: relay output n°2.

13 - 14: optical input n°1.

15 - 16: optical input n°2.

Memory module

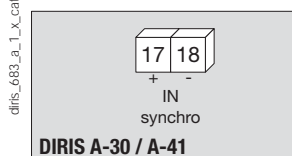

17 - 18: synchronisation input.

Temperature module

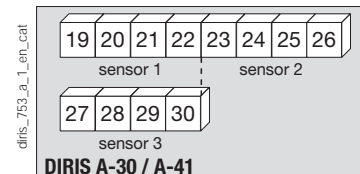

Probe 1	Probe 2	Probe 3
19: red	23: red	27: red
20: red	24: red	28: red
21: white	25: white	29: white
22: white	26: white	30: white

Ethernet module

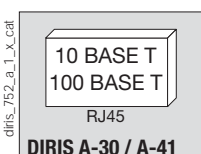

Ethernet module + RS485 MODBUS gateway

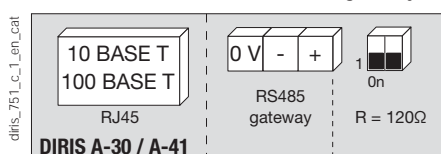

Electrical characteristics

Measurement of currents on insulated inputs (TRMS)	
Via CT primary	9,999 A
Via CT secondary	1 or 5 A
Measurement range	0 ... 11 kA
Input consumption	≤ 0,1 VA
Measurement updating period	1 s
Accuracy	0.2%
Permanent overload	6 A
Intermittent overload	10 I _n for 1 s
Voltage measurements (TRMS)	
Direct measurement between phases	50 to 1039 VAC
Direct measurement between phase and neutral	28 to 600 VAC
VT primary measurement	500,000 VAC
VT secondary measurement	60, 100, 110, 173, 190 VAC
Frequency	50 / 60 Hz
Input consumption	≤ 0,1 VA
Measurement updating period	1 s
Accuracy	0.2%
Current - voltage product	
Limitation for TC 1 A	10,000,000
Limitation for TC 5 A	10,000,000
Power measurement	
Measurement updating period	1 s
Accuracy	0.5%
Power factor measurement	
Measurement updating period	1 s
Accuracy	0.5%
Frequency measurement	
Measurement range	45 ... 65 Hz
Measurement updating period	1 s
Accuracy	0.1%
Energy accuracy	
Active (according to IEC 62053-22)	Class 0.5 S
Reactive (according to IEC 62053-23)	Class 2
Auxiliary power supply	
Alternative voltage	110 ... 400 VAC
AC tolerance	± 10 %
Direct current	120 ... 350 VDC / 12 ... 48 VDC
DC tolerance	± 20 % / - 6 ... + 20 %
Frequency	50 / 60 Hz
Power consumption	≤ 10 VA

Module 2 inputs - 2 outputs: outputs (alarms / control)	
Number of relays	2 ⁽¹⁾
Type	250 VAC - 5 A - 1150 VA
Module 2 inputs - 2 outputs: optical coupler inputs	
Number	2 ⁽¹⁾
Power supply	10 ... 30 VDC
Minimum width of signal	10 ms
Minimum length between 2 pulses	18 ms
Type	Optical couplers
Pulse output module	
Number of relays	2
Type	100 VDC - 0.5 A - 10 VA
Max. number of manoeuvres	≤ 10 ⁸
Analogue output module	
Number of outputs	2 ⁽²⁾
Type	Insulated
Scale	0 / 4 ... 20 mA
Load resistance	600 Ω
Maximum current	30 mA
MODBUS communication module	
Link	RS485
Type	2 to 3 half duplex wires
Protocol	MODBUS [®] RTU
MODBUS [®] speed	4800 to 38400 baud
PROFIBUS DP communication module	
Link	SUB-D9
Protocol	PROFIBUS [®] DP
PROFIBUS [®] speed	9.8 kbaud ... 12 Mbaud
Ethernet communication module	
Connection technology	RJ45
Baud rate	10 base T / 100 base T
Protocol	MODBUS TCP or MODBUS RTU on TCP
Temperature module (inputs)	
Type	PT100
Connection	2, 3 or 4 wires
Dynamic	- 20°C ... 150°C
Accuracy	± 1 digit
Maximum length	300 cm
Operating conditions	
Operating temperature range	-10 to +55°C
Storage temperature	-20 to 85°C
Relative humidity	95%

(1) Max. 3 modules / DIRIS.
(2) Max. 2 modules / DIRIS.

Case

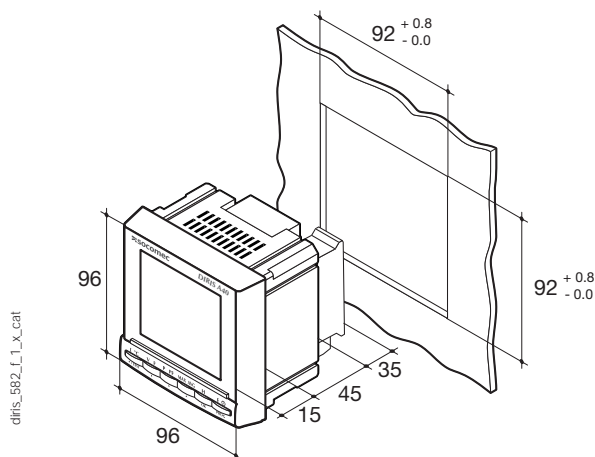

Type	Panel mounting
Dimensions W x H x D	96 x 96 x 60 mm
Case degree of protection	IP30
Front degree of protection	IP52
Display type	Backlit LCD display
Type of terminal strips	Fixed or detachable
Section of connection for voltages and other terminals	0,2 ... 2,5 mm ²
Section of connection for currents	0,5 ... 6 mm ²
Weight	400 g

DIRIS A-30/A-41

Multifunction measuring unit - PMD

measurement and advanced monitoring - door mounting

Connections

Balanced low-voltage network for DIRIS A-30

Recommendation: When disconnecting the DIRIS, the secondary of each current transformer must be short-circuited. This operation can be carried out automatically by a SOCOMEC PTI, which can be found in the SOCOMEC catalogue: please consult us. In TNC mode, it is advisable to connect the DIRIS A-30/A-41 to earth using the functional earth module.

3/4 wires with 1 CT

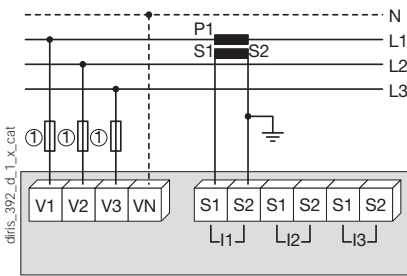

The use of 1 TC reduces by 0.5% the accuracy of the phases, the current for which is worked out by vector calculation.
1. 0.5 A gG / 0.5 A class CC fuses.

Single-phase

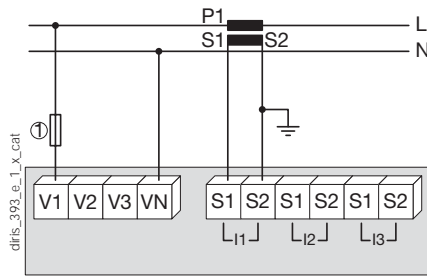

1. 0.5 A gG / 0.5 A class CC fuses.

Two-phase

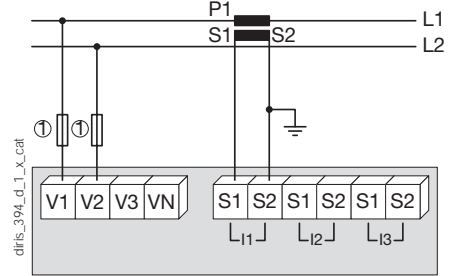

1. 0.5 A gG / 0.5 A class CC fuses.

Balanced low-voltage network for DIRIS A-30

3/4 wires with 3 CTs

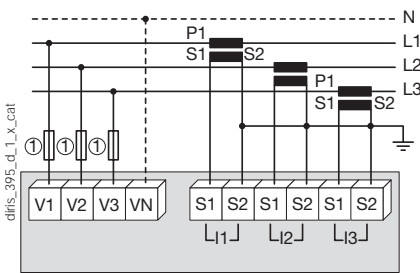

1. 0.5 A gG / 0.5 A class CC fuses.

3 wires with 2 CTs

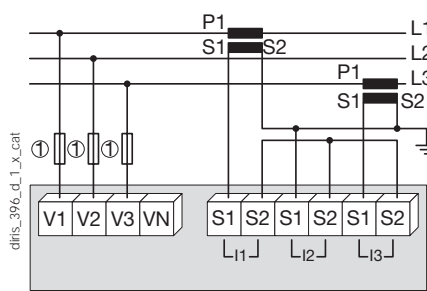

The use of 2 TC reduces by 0.5% the accuracy of the phase, the current for which is worked out by vector calculation.
1. 0.5 A gG / 0.5 A class CC fuses.

3 wires with 2 CTs

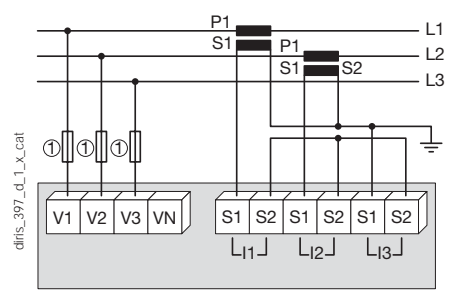

The use of 2 TC reduces by 0.5% the accuracy of the phase, the current for which is worked out by vector calculation.
1. 0.5 A gG / 0.5 A class CC fuses.

Balanced low-voltage network for DIRIS A-41

4 wires with 4 CTs

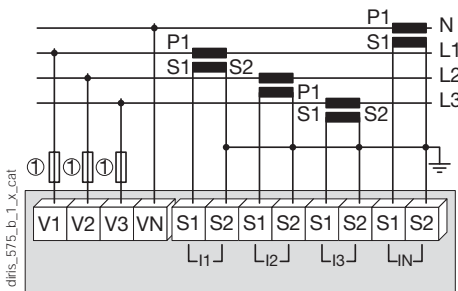

1. 0.5 A gG / 0.5 A class CC fuses.

Additional information

Communication via RS485 link

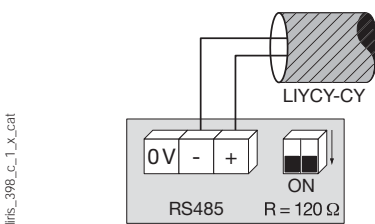

Connection of potential transformer for HV networks

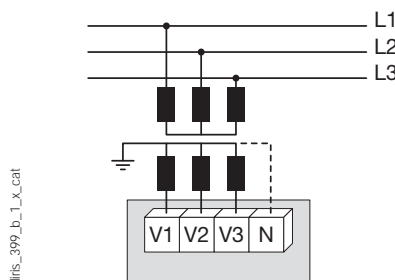

AC and DC auxiliary power supply

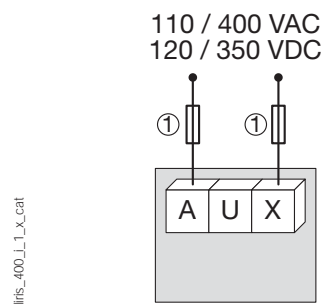

References

Basic device	DIRIS A-30		DIRIS A-41 With CT on the neutral
Auxiliary power supply U_s	Reference		Reference
110 ... 400 VAC / 120 ... 350 VDC	4825 0403		4825 0404
12 ... 48 VDC	4825 0405		4825 0406

Options			
Plug-in modules⁽¹⁾	Reference		Reference
Pulse outputs	4825 0090		4825 0090
RS485 MODBUS® communication	4825 0092		4825 0092
PROFIBUS® DP communication	4825 0205		4825 0205
Analogue outputs	4825 0093		4825 0093
2 inputs - 2 outputs	4825 0094		4825 0094
Storage capability	4825 0097		4825 0097
Ethernet communication ⁽²⁾	4825 0203		4825 0203
Ethernet communication + RS485 gateway ⁽²⁾	4825 0204		4825 0204
Temperature inputs.	4825 0206		4825 0206

(1) Ease of integration of additional functions (maximum 4 slots on A-30 and 3 on A-41).

(2) Dimensions: 2 slots.

Accessories	To be ordered in multiples of	Reference	To be ordered in multiples of	Reference
IP65 protection.	1	4825 0089	1	4825 0089
Integration kit for 144 x 96 mm cutout	1	4825 0088	1	4825 0088
Fuse holders to protect voltage inputs (type RM) 3 pole	4	5701 0018	4	5701 0018
Fuse holders to protect the auxiliary power supply (type RM) 1 pole + neutral	6	5701 0017	6	5701 0017
gG 10x38 0.5 A fuses	10	6012 0000	10	6012 0000
Range of current transformers	1	See "Current transformers" pages	1	See "Current transformers" pages
Ferrite for use with communication modules	1	4899 0011		4899 0011
PT100 temperature probe, M6 screw	1	4825 0208	1	4825 0208
PT100 temperature probe, M6 lug	1	4825 0209	1	4825 0209
Associated DIRIS software		See "Easy Config System" pages		
Automatic CT short-circuiting device		See "Current transformers" pages		

Expert Services

- > Study, definition, advice, implementation, maintenance and training... Our experts "Expert Services" offer complete support for the success of your project.



DIRIS A-40

Multifunction measuring unit - PMD

measurement, monitoring and event analysis with smart sensors - door mounting



DIRIS A-40

The solution for

- > Industry
- > Building
- > Infrastructure



Strong points

- > Assisted configuration
- > Connected to the Cloud
- > Compliant with IEC 61557-12
- > Smart sensors

Integrated technologies



For more information see our website
www.socomec.com

Conformity to standards

- > IEC 61557-12
- > UL E257746
- > EN 50160



Function

The DIRIS A-40 is a panel-mounted power monitoring device (PMD). It is designed for measuring, monitoring and reporting electrical energy.

The DIRIS A-40 offers a range of functions for measuring voltage, current, power, energy and quality.

It allows the analysis of a single-phase or three-phase load.

Advantages

Assisted configuration

The configuration wizard guides the user step by step. It also detects and corrects configuration errors. This cuts the commissioning time in half and always delivers a reliable result.

Connected to the Cloud

The range comprises IoT ready connected products that enable data to be exported automatically for remote operation without any limit on time, distance and time in storage.

Smart sensors

Three current sensor formats (solid-core TE, split-core TR/ITR and Rogowski coil TF) allow integration of the DIRIS A-40 into new and existing electrical installations.

Compliant with IEC 61557-12

Reference standard for PMDs (Performance metering & monitoring devices), IEC 61557-12 standard guarantees performance levels and satisfactory performance from the PMDs under the environmental conditions typical of industrial and tertiary applications.

Functions

Multi-measurement

- Currents
 - I1, I2, I3, In, Isystem
- Voltages & frequency
 - V1, V2, V3, VN, Vsystem, U12, U23, U31, Ussystem, f
- Powers
 - P1, P2, P3, ΣP, Q1, Q2, Q3, ΣQ, S1, S2, S3, ΣS
 - Predictive powers ΣP, ΣQ, ΣS
- Power factor
 - PF1, PF2, PF3, ΣPF
- Cos φ & tangent φ
 - Instantaneous values per phase

Metering

- Active energy: +/- kWh
- Reactive energy: +/- kvarh
- Apparent power: kVAh
- Multi-tariff (8 max.)
- Hour Meter

Quality

- Voltage Unbalance
 - Vdir, Vinv, Vhom, Udir, Uinv, Unba, Vhba, Vnb, Unb
- Current unbalance
 - Idir, linv, Ihom, Inba, Inb
- Total harmonic distortion
 - Currents THDi1, THDi2, THDi3, THDIN, TDDI
 - Phase-to-neutral voltage THDv1, THDv2, THDv3
 - Phase-to-phase voltage THDu12, THDu23, THDu31
- Individual harmonics up to 63rd
 - Currents: HI1, HI2, HI3, HIn
 - Phase-to-neutral voltage: HV1, HV2, HV3
 - Phase-to-phase voltage: HU12, HU23, HU31
- Kfactor & Crest factor
- Events according to EN 50160
 - Voltage dips, outages, interruptions, swells
- Waveform capture
 - Automatic waveform captures when event occurs, and manual recording of the waveform
 - Available through communication

Monitoring of protection

- Auxiliary contact monitoring
- Report and alarm on trips
- Number of operations

Load curves and historical records (max. 130 days)

- Active, reactive and apparent power
- Currents, voltages and frequency

Alarms

- Alarms for all electrical values, events and input status changes, possibility of logical combination
- Time-stamping of events

Communication

- DIRIS A-40 RS485 Modbus as standard
- DIRIS A-40 Ethernet Modbus
- DIRIS A-40 PROFIBUS DPV1

Inputs

- 3 digital inputs
 - Power supplied from DIRIS A-40 or an external source
 - Function: logic status, status of circuit breaker, counting of pulses or synchronization multifund metering
- 2 logical outputs
 - Function: Command, energy pulse output, load shedding, alarm

Functions

Monitoring

- Real-time measurement of electrical values.
- View data as graphs or tables.
- Power quality analysis of the utility supply and of loads.



Metering

- Measurement of active, reactive and apparent energies.
- Historical record of measurements.
- Graphic display on monthly, weekly, daily or hourly basis.



Alarming

- Display of alarms.
- History of alarms.



Terminals

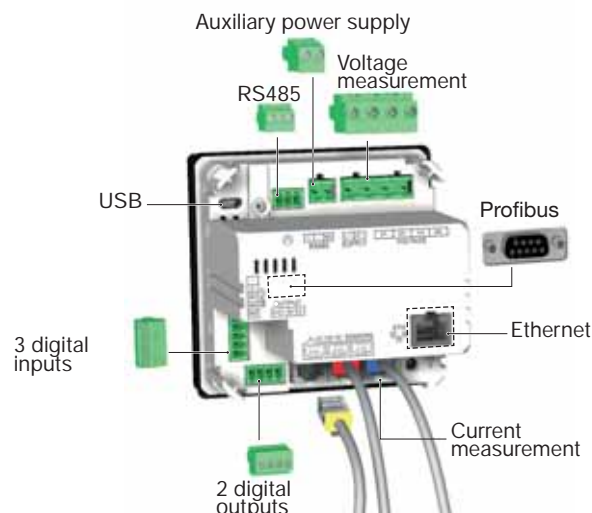

Dimensions (mm)

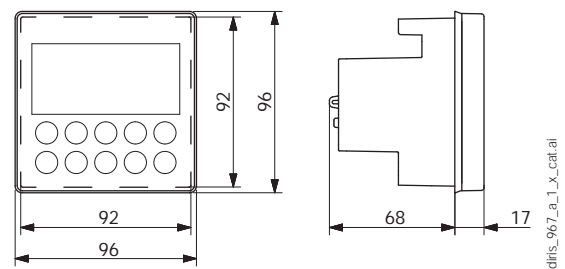

Current measurement

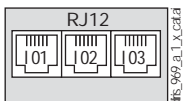

3 inputs supplied by the product

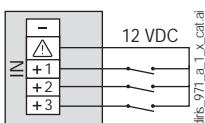

3 inputs with external power supply

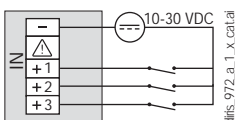

Voltage connections inc auxiliary power supply

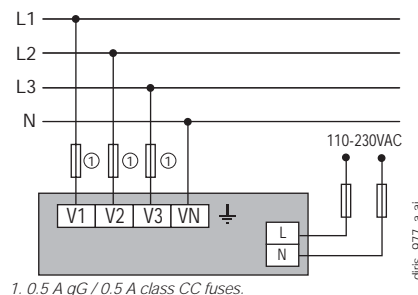

2 outputs

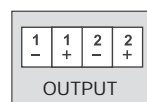

Earth



RS485

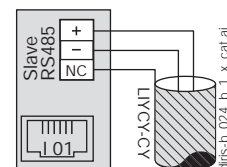

DIRIS A-40

Multifunction measuring unit - PMD

measurement, monitoring and event analysis with smart sensors - door mounting

Connections

Associated current sensors

Various types of current sensors can be connected to the DIRIS A-40: solid-core (TE), split-core (TR/iTR) or Rogowski (TF). This range of sensors is suitable for all types of new or existing installations. A quick RJ12 connection makes wiring easy and reliable and prevents wiring errors. The DIRIS A-40 automatically recognizes the sensor size and type. This guarantees the overall accuracy of the DIRIS A-40 + current sensor measurement chain. For more information: see "TE, TR/iTR, TF sensors" pages.

TE solid current sensors



TE / TR/iTR / TF current sensors



Network and connection examples

Three-phase + Neutral

3P+N - 3 CT (1 three-phase load + calculated Neutral)

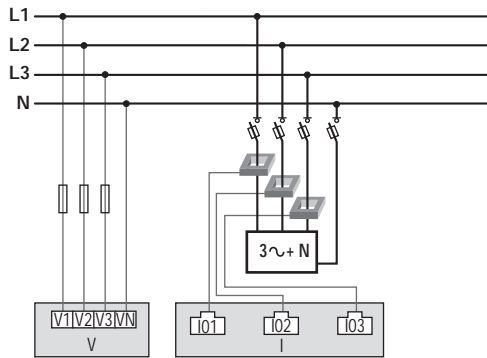

Three-phase

3P - 3CT (1 three-phase load)

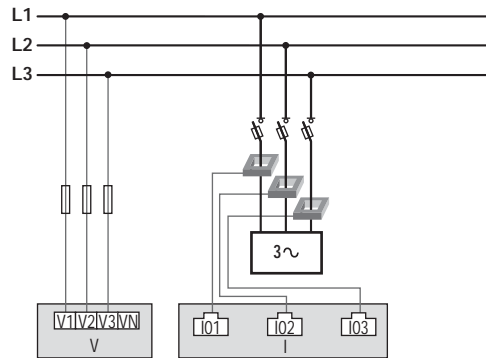

Three-phase

3P - 1CT (1 balanced three-phase load)

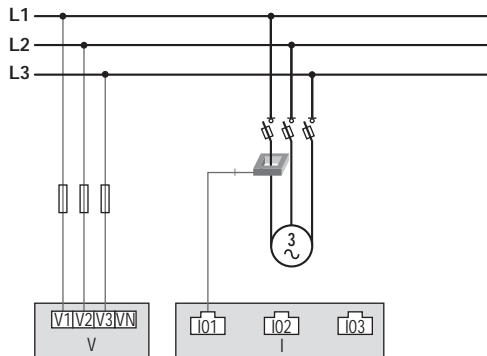

Single-phase

1P+N - 1CT (1 single-phase load)

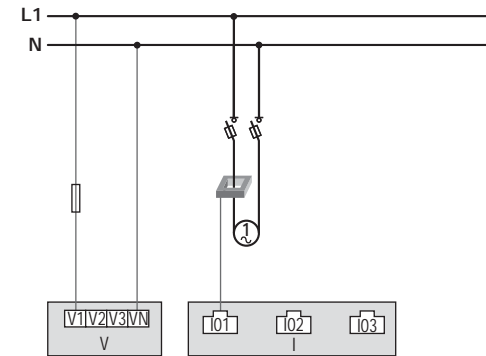

1. 0.5 A gG / 0.5 A class CC fuses.
If self-supplied, a fuse must always be added to the Neutral.



DIRIS A-40 characteristics

Electrical characteristics

Auxiliary power supply	
Alternative voltage	110/400 VAC or 120/300 VDC - Cat III
Frequency	50/60 Hz
Power consumption	5VA AC / 1,5VA DC (48250500) 8VA AC / 2,5VA DC (48250501 & 48250502)
Connection	Removable spring-cage terminal block, 2x 2 positions, 0.5 - 2.5 mm ² solid cable or 0.25 - 1.5 mm ² stranded cable with end piece

Measurement characteristics

Power and energy measurement	
Accuracy	Class 0.2 DIRIS A-40 only
Active energy and active power	Class 0.5 with TE, TF or iTR sensors Class 1 with TR sensors
Accuracy of reactive energy	Class 2 with TE, TR/iTR or TF sensors

Power factor measurement	
Accuracy	Class 0.5 with TE, TF or iTR sensors Class 1 with TR sensors

Voltage measurement	
Characteristics of the network measured	50-300VAC (Ph/N) - 87-520VAC (Ph/Ph) - CAT III
Frequency range	45 to 65Hz
Frequency accuracy	Class 0.02
Network type	Single-phase/ Two-phase / Two-phase with neutral / Three-phase / Three-phase with neutral
Measurement by voltage transformer	Primary: 400 000 VAC Secondary: 60, 100, 110, 173, 190 VAC
Input consumption	≤ 0,1 VA
Accuracy of voltage measurement	Class 0.2

Current measurement	
Number of current inputs	3
Associated current sensors	Solid TE, split-core TR/iTR, flexible TF current sensors
Accuracy	0.2 DIRIS A-40 class only Class 0.5 with TE, TF or iTR sensors Class 1 with TR sensors
Connection	Specific Socomec cable with RJ12 connectors

Input characteristics

Number	3
Type / Power supply	Optocoupler with internal (12 VDC ± 10%) or external (12-24 VDC ± 20%) polarisation
Input function	Logic status, status of circuit breaker, synchronization topography, multifluid pulse metering
Connection	Removable screw terminal block, 5 positions, stranded or solid 0.14 - 1.5 mm ² cable

Output characteristics

Number	2
Type	Optocoupler 30 Vd.c. max 20mA max - SELV
Output function	Command, energy pulse output, load shedding, alarm
Connection	Removable screw terminal block, 4 positions, stranded or solid 0.14 - 1.5 mm ² cable

Communication characteristics

DIRIS A-40 RS485	
Link	RS485
Connection type	2 to 3 half duplex wires
Protocol	Modbus RTU
Baud rate	1200 to 115 200 baud
USB	Configuration of DIRIS A-40

References

DIRIS A-40 monitoring devices		Reference
DIRIS A-40	RS485 Modbus - 3 inputs / 2 outputs	4825 0500
DIRIS A-40	Ethernet Modbus TCP or BACnet IP - webserver - RS485 Modbus - 3 inputs / 2 outputs	4825 0501
DIRIS A-40	Profibus DPV1 - RS485 Modbus - 3 inputs / 2 outputs	4825 0502
Accessories		Reference
Fuse disconnect switches to protect voltage inputs (RM type)		To be ordered in multiples of 4 5701 0018
Fuse disconnect switches to protect the 1-pole + neutral auxiliary power supply (RM type)		6 5701 0017
gG 10x38 0.5 A fuses		10 6012 0000

DIRIS B

Multifunction measuring unit - PMD

measurement, monitoring and event analysis with smart sensors - modular format



DIRIS B-10 / B-30
RS485

diris-b_038.eps



Configuration
with Easy Config System.

Function

The DIRIS B is a power monitoring device in a modular format that communicates via RS485. The 4 RJ12 independent current inputs of the device allow it to manage several types and number of circuits: for example, 4 single-phase loads or 1 three-phase load + 1 single-phase load.

The DIRIS B is connected to current sensors (RJ12 connection) that are suitable for all types of installation: solid TE, split-core TR/ITR, and flexible TF current sensors.

Advantages

Plug & Play

A rapid RJ12 connection makes wiring easy and reliable and prevents wiring errors. Automatically addressing and configuring the product (communication address, load type, type and ratio of current sensor) allow you to simplify implementation and to save time.

Class 0.5 in accordance with IEC 61557-12

- Class 0.2 for the meter alone.
- Class 0.5 from 2% to 120% of nominal current for the global measurement chain (associated with TE/ITR/TF current sensors).

Multi-circuit

- 4 current measurement inputs allow you to configure multiple circuits in order to optimise the number of measurement devices per installation.

Communication

- The DIRIS B can be connected to:
 - a remote DIRIS D-30 screen for displaying measurement and metering data,
 - DIRIS Digiware M-50/M-70 gateways for centralisation and communication of data via Ethernet. DIRIS Digiware M-70 embeds WEBVIEW-M, a webserver for remote visualisation of measurement data,
 - optional modules for more communication options including a second RS485 port or PROFIBUS DP protocol. Digital or Analog input/output, as well as temperature input modules can also be connected.

The solution for

- > Industry
- > Building
- > Infrastructure
- > Local authority



Strong points

- > Plug & Play
- > Global accuracy class 0.5 in accordance with IEC 61557-12
- > Multi-circuit
- > Communication

Integrated technologies





For more information see our website
www.socomec.com

Conformity to standards

- > UL E257746
- > IEC 61557-12
- > EN 50160
- > ISO 14025



Application	Local metering	Local analysis
		
DIRIS B	B-10 RS485	B-30 RS485
Number of current inputs	4	4
Metering		
± kWh, ± kvarh, kVAh	•	•
Load curves		•
Multi-tariff	•	•
Multi-measurement		
U12, U23, U31, V1, V2, V3, f	•	•
U system, V system	•	•
I1, I2, I3, In, ΣP, ΣQ, ΣS, ΣPF	•	•
P, Q, S, PF per phase	•	•
Predictive power	•	•
Ph/N unbalance	•	•
Ph/Ph unbalance	•	•
Current unbalance (Inba, Idir, linv, lhom, lnb)	•	•
Phi, cos Phi, tan Phi	•	•
Quality analysis		
THDv1, THDv2, THDv3, THDu12, THDu23, THDu31	•	•
THDi1, THDi2, THDi3, THDin	•	•
Individual harmonics U & V (up to 63 rd)		•
Individual harmonics I (up to 63 rd)		•
Crest factor I1, I2, I3, In		•
Crest factor V1, V2, V3, U12, U23, U31		•
Voltage dips, interruptions, swells (EN 50160)		•
Overcurrents		•
Alarms		
On threshold		•
Inputs/outputs		•
History of average values		
45 days (max)		•
Communication		
RS485 Modbus	•	•
2 inputs (status/pulse)	•	•

Accessories

DIRIS B sealing cover

- Prevents access to the cabling of the monitoring device.



USB configuration cable (2 m)

- Advanced configuration of DIRIS B gateways can be achieved using the EASY CONFIG software via Ethernet or direct USB connection.

DIRIS B

Multifunction measuring unit - PMD

measurement, monitoring and event analysis with smart sensors - modular format

DIRIS D-30 display

DIRIS D-30

Connection



diris-d_001_a_1_cat



diris-d_004_b_1_x_cat

DIRIS D-30

DIRIS B

Optional modules

DIRIS O



diris-b_031_a

Optional module

DIRIS B



Optional modules (4 max.)*

- Digital inputs/outputs
- Analogue inputs/outputs
- Temperature inputs
- Communication protocols

* maximum 4 optional modules with maximum 1 temperature module and 1 communication module (Modbus, PROFIBUS).



diris-o_019_a

DIRIS O-iod

- 2 digital inputs centralises the metering pulses or the input status changes of the auxiliary contacts.
- 2 digital outputs can be connected to configurable alarms warning of exceeded thresholds (power, current, etc.) or can be piloted remotely.



diris-o_018_a

DIRIS O-ioa

- 2 inputs (4-20 mA) centralise analogue sensors (pressure, humidity, temperature, etc.)
- 2 outputs (4-20 mA) report the measurements (power, currents, etc.) to PLCs.



diris-o_020_a

DIRIS O-it

- 3 temperature inputs to be connected to PT100 or PT1000 sensors.
- Ambient air temperature.



diris-o_024_a

DIRIS O-m

- Provides a second RS485 Modbus communication port to the DIRIS B for simultaneous sending of information via RS485 to two supervision stations.



diris-o_023_a

DIRIS O-p

- Adds a PROFIBUS DPV1 communication port to the DIRIS B.

DIRIS B terminals

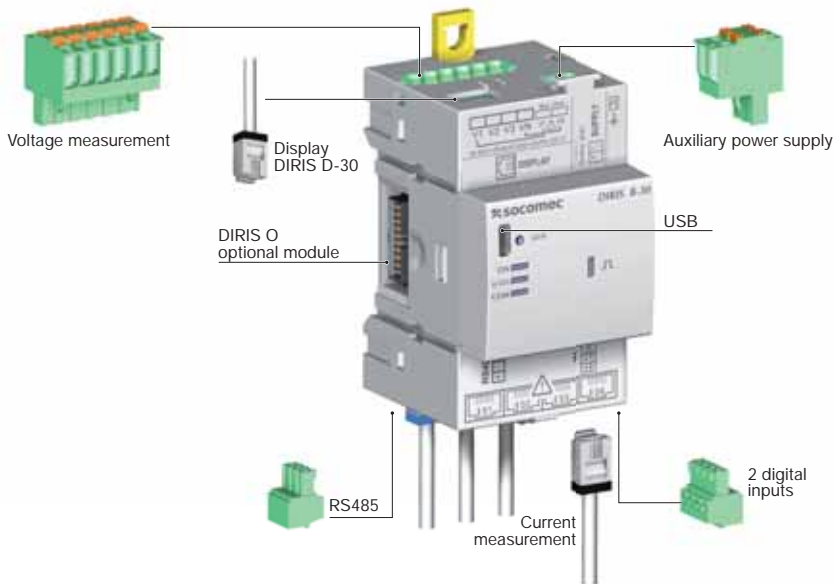

dfiris-d_027_b_1_gb_cat

Current measurement

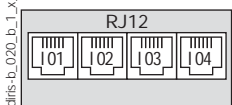

Voltage measurement and auxiliary power supply

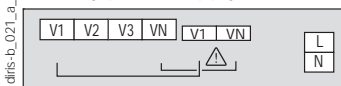

2 inputs supplied by the product

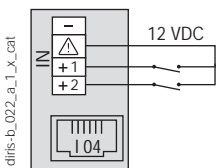

dfiris-b_022_a_1_x_cat

Self supply

Easy connection of the power supply from the measurement terminal (specific terminals)

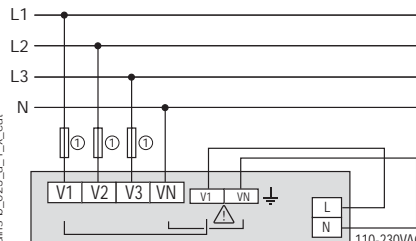

1. Fuses 0.5 A gG / 0.5 A class CC.

2 inputs with external power supply

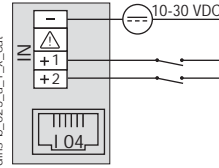

dfiris-b_023_a_1_x_cat

Separate power supply

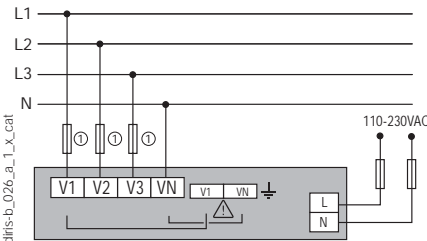

1. Fuses 0.5 A gG / 0.5 A class CC.

RS485

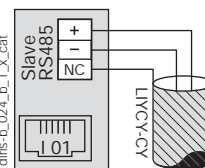

dfiris-b_024_b_1_x_cat

RJ9 for DIRIS D-30 (self-supply and data)



dfiris-b_019_a_1_x_cat

Terminals of optional DIRIS O modules

Optional module power supply

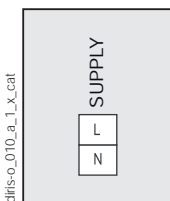

dfiris-o_010_a_1_x_cat

DIRIS O-iod

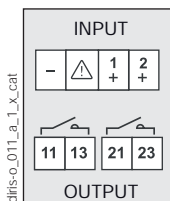

dfiris-o_011_a_1_x_cat

DIRIS O-ioa

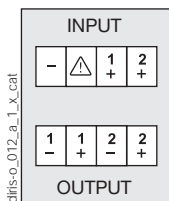

dfiris-o_012_a_1_x_cat

DIRIS O-it

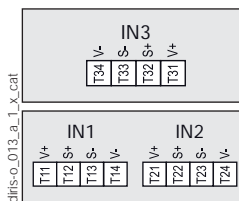

dfiris-o_013_a_1_x_cat

DIRIS O-m RS485

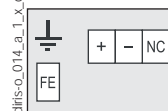

dfiris-o_014_a_1_x_cat

DIRIS O-p

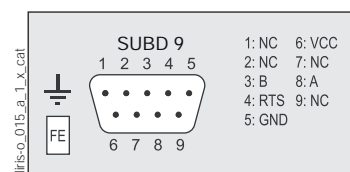

dfiris-o_015_a_1_x_cat

DIRIS B

Multifunction measuring unit - PMD

measurement, monitoring and event analysis with smart sensors - modular format

Connections

Associated current sensors

Various types of current sensors can be connected to the DIRIS B: solid-core TE, split-core TR/iTR, flexible TF current sensors. This range of sensors can be adapted to all types of new or existing installations. A rapid RJ12 connection makes wiring easy and reliable and prevents wiring errors. The DIRIS B automatically recognises the type of sensor used and its current rating. This guarantees the overall accuracy of the DIRIS B + current sensor measurement chain. For more information: see "TE, TR/iTR, TF sensors" pages.

TE solid-core current sensors

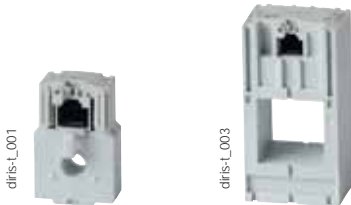

TR/iTR split-core current sensors



TE / TR / iTR / TF current sensors



Network and connection examples

Three-phase + neutral

3P+N - 4CTs (measurement for 1 three-phase load + Neutral)

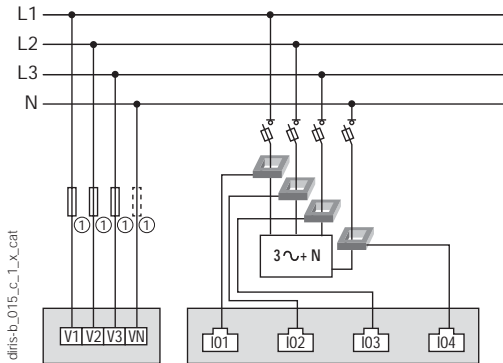

1. Fuses 0.5 A gG / 0.5 A class CC.

Three-phase

3P - 2CTs (2 three-phase loads without neutral)

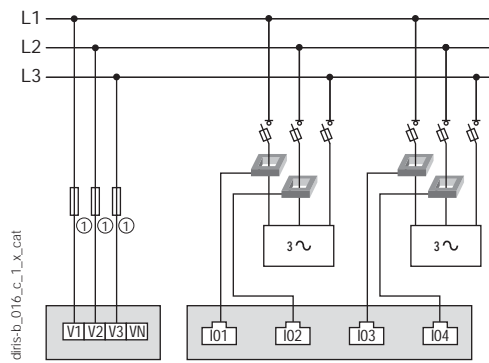

1. Fuses 0.5 A gG / 0.5 A class CC.

Three-phase

3P+N - 3CTs & 1P+N - 1CT (1 three-phase load & 1 single-phase load)

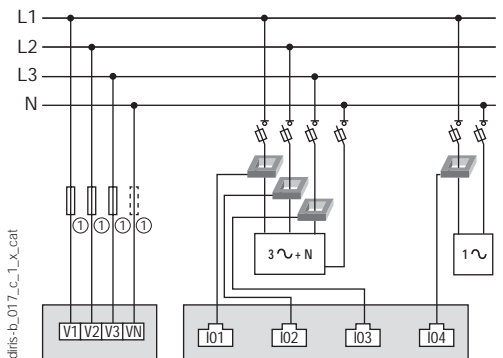

1. Fuses 0.5 A gG / 0.5 A class CC.

In case of self-supply, a fuse must be added on the neutral.

Single-phase

1P+N-1CT (4 single-phase loads)

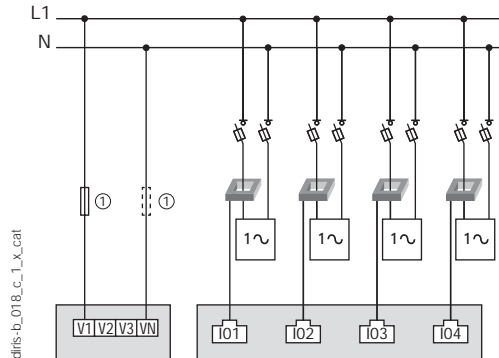

1. Fuses 0.5 A gG / 0.5 A class CC.

CT: Current sensors 3~ Load

Dimensions (mm)

DIRIS B

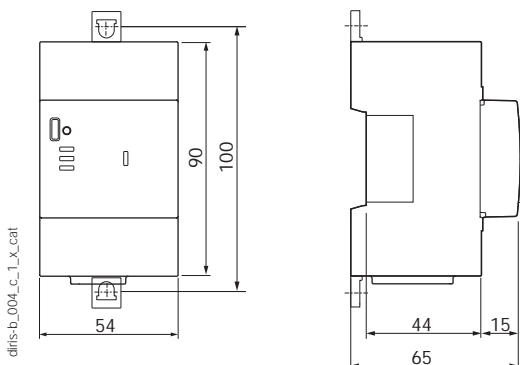

DIRIS O optional modules

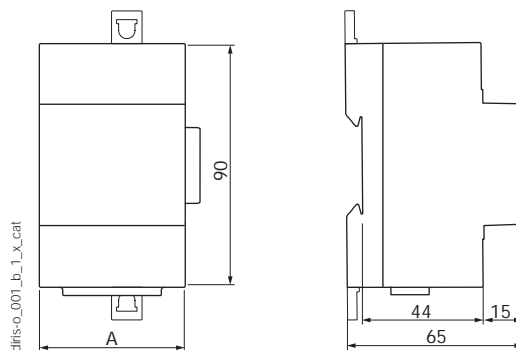

DIRIS O optional modules	A (mm)
DIRIS O-iod - DIRIS O-ioa - DIRIS O-it	45
DIRIS O-m - DIRIS O-p	54

DIRIS D-30

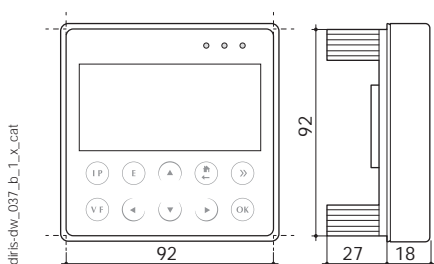

Communication architecture

Example of communication architecture with DIRIS Digiware M-70 gateway and WEBVIEW-M embedded web server.

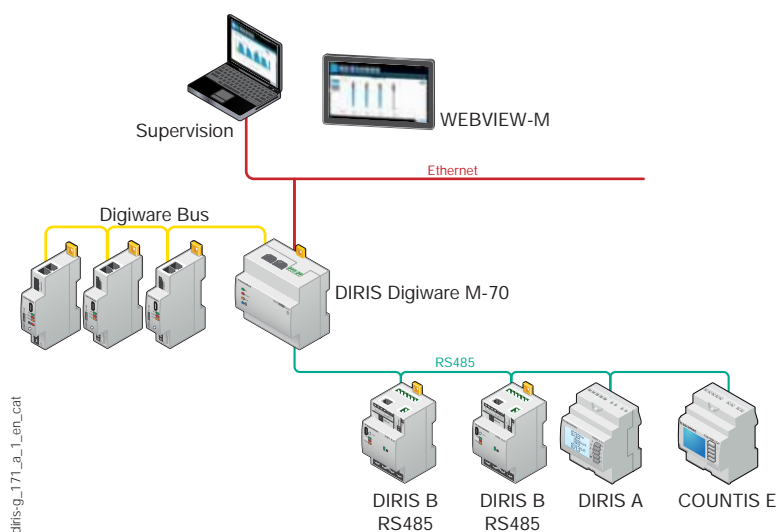

DIRIS B

Multifunction measuring unit - PMD

measurement, monitoring and event analysis with smart sensors - modular format

DIRIS B characteristics

Electrical characteristics

Auxiliary power supply	
AC voltage	110-230 VAC ±15 % (Ph/N ou Ph/Ph) Cat III
Frequency	50/60 Hz
Consumption	< 2 VA without display < 6VA with display
Connection	Removable spring-cage terminal, 2 x 2 positions, 0.5 ... 2.5 mm ² solid cable or 0.25 ... 1.5 mm ² stranded cable with ferrule

Measurement characteristics

Energy and power measurement	
Accuracy	Class 0.2 DIRIS B alone
Active energy and active power	Class 0.5 with TE, iTR or TF current sensors Class 1 with TR current sensors
Reactive energy accuracy	Class 2 with TE, TR or TF current sensors

Power factor measurement	
Accuracy	Class 0.5 with TE, iTR or TF current sensors Class 1 with TR current sensors

Voltage measurement	
Network characteristics measured	50-300VAC (PhN) - 87-520VAC (Ph/Ph) - CAT III
Frequency range	45 ... 65Hz
Frequency accuracy	Class 0.02
Network type	Single-phase / Two-phase / Two-phase with neutral / Three-phase / Three-phase with neutral
Measurement by voltage transformer	Primary: 400 000 VAC Secondary: 60, 100, 110, 173, 190 VAC
Input consumption	≤ 0.1 VA
Permanent overload	300VAC Ph/N
Voltage measurement accuracy	Class 0.2

Current measurement	
Number of current inputs	4
Associated current sensors	Solid TE , split-core TR/iTR , flexible TF current sensors
Accuracy	Class 0.2 DIRIS B alone Class 0.5 with TE, iTR or TF current sensors Class 1 with TR current sensors

Input characteristics

Number	2
Type / Power supply	Optocoupler internal polarisation (12 VDC ± 10 %) or external polarisation (10-30 VDC ± 10%)

Communication characteristics

DIRIS B RS485	
Link	RS485
Connection type	2 ... 3 half duplex wires
Protocol	Modbus RTU
Speed	1200 ... 115200 bauds
USB	DIRIS B RS485 configuration

Environment characteristics

Operating temperature	-10 ... +70 °C
Storage temperature	-25 ... +85 °C
Operating humidity	55 °C / 97% relative humidity
Operating altitude	2000 m
Vibration	1G from 10 to 100Hz

DIRIS D-30 display characteristics

Mechanical characteristics	
Screen type	Capacitive touch-screen technology, 10 keys
Screen resolution	350 x 160 pixels
Single product connection	
RJ9	Self-supply and data
Micro-USB	Updating
Degree of protection	IP65 (front face)
Environment	
Storage temperature (°C)	-20 ... +70°C
Operating temperature (°C)	-20 ... +70°C
Humidity	95 % to 40°C
Installation category	CAT III
Degree of pollution	2

DIRIS O optional modules characteristics

Power supply ⁽¹⁾	
AC voltage	110-230 VAC ±15 %
Frequency	50/60 Hz

(1) No power supply on DIRIS O-it.

DIRIS O-iod - 2 digital inputs/2 digital outputs	
Number of inputs	2 per optional modules - max. 4 optional modules
Type	Optocoupler internal polarisation (12 VDC ± 10 %) or external polarisation (10-30 VDC ± 10%)
Function	Logic status or pulse meter
Number of outputs	2 per optional modules - max. 4 optional modules
Type	Relay / 230 VAC ±15 % - 1 A
Function	Configurable alarm (current, power...) on threshold overruns or remote controlled status
Inputs/Outputs connection	Removable screw terminal, 4 positions, 0.14 to 1.5 mm ² stranded or solid cable

DIRIS O-ioa - 2 analogue inputs/2 analogue outputs	
Number of inputs	2 per optional modules - max. 4 optional modules
Type	4-20 mA
Function	Connection of analogue sensors (pressure, humidity, temperature...)
Number of outputs	2 per optional modules - max. 4 optional modules
Type	4-20 mA

DIRIS O-it - 3 temperature inputs	
Number of inputs	3 external inputs + 1 measurement for ambient temperature
Dynamic	-20 ... 150 °C
Type	PT100 or PT1000

DIRIS O-m - RS485 communication	
Link	RS485 2 ... 3 half duplex wires
Protocol	Modbus RTU
Speed	1200 ... 115200 bauds
Connection	Removable screw terminal, 3 positions, 0.14 to 1.5 mm ² stranded or solid cable

DIRIS O-p - PROFIBUS communication	
Protocol	PROFIBUS DPV1

References

DIRIS B monitoring devices		Reference
DIRIS B-10	RS485 - Modbus - 230 VAC	4829 0010
DIRIS B-30	RS485 - Modbus - 230 VAC	4829 0000
DIRIS O optional modules		Reference
DIRIS O-iod	2 digital inputs / 2 digital outputs	4829 0030
DIRIS O-ioa	2 analogue inputs/2 analogue outputs 4-20 mA	4829 0031
DIRIS O-it	3 temperature inputs PT 100 / PT 1000	4829 0032
DIRIS O-m	RS485 Modbus communication	4829 0033
DIRIS O-p	PROFIBUS communication	4829 0034
Accessories		To be ordered in multiples of
DIRIS D-30 - Single-point display		4829 0200
RJ9 cable for DIRIS D-30 display - 1.5 m		4829 0280
RJ9 cable for DIRIS D-30 display - 3 m		4829 0281
DIRIS B sealing cover for I/O terminals		4829 0049
USB configuration cable		4829 0050
Fuse disconnect switches to protect voltage inputs (RM type)	4	5701 0018
Fuse disconnect switches to protect the 1-pole + neutral auxiliary power supply (RM type)	6	5701 0017
gG 10x38 0.5 A fuses	10	6012 0000

DIRIS B-10L*

LoRaWAN® Power Monitoring Device

new



DIRIS B-10L



Configuration with
Easy Config System.

Function

The **DIRIS B-10L** is a modular power monitoring device embedding a LoRaWAN® wireless communication.

Its four independent RJ12 current inputs make it possible to manage several types of loads: e.g. 4 single-phase loads or one 3-phase load + 1 single-phase load.

The DIRIS B-10L is associated with current sensors (RJ12 connection), suitable for any type of installation: TE solid core, TR / ITR split core and TF flexible current sensors.

Advantages

Plug & Play

The connection is simple thanks to the RJ12 rapid connector which limits the risk of wiring errors. Addressing and automatic configuration of the product (type of load, type and size of current sensor) make it possible to simplify the implementation and to save time.

Accurate

- In accordance with standard IEC 61557-12.
- Class 0.2 for just the DIRIS B-10L alone.
- Class 0.5 for the global measuring chain (DIRIS B-10L + TE/ITR/TF current sensors) from 2 to 120% of rated current In.

Wireless communication

LoRaWAN® communication permits the transmission and use of data from remote isolated measuring points that do not have wired communication.

Long range

The choice of use over both private or operated LoRaWAN® networks makes it possible to cover single-site or multi-site applications, reducing the range limitations.

Secure communication

Communication between B-10L and the LoRaWAN gateways feature end-to-end encryption that ensures confidentiality and integrity of measurement data.

*Europe only

The solution for

- > Industry
- > Buildings
- > Infrastructure



Strong points

- > Plug & Play
- > Accurate
- > Wireless communication
- > Long range
- > Secure communication

Créez votre projet

- > Assistance à la définition de votre architecture LoRaWAN®

IoT SELECTOR



www.socomec-iot-selector.com

Compliance with standards

- > IEC 61557-12
- > LoRaWAN®



- > ISO 14025



Services experts



Socomec offers a range of services to ensure a functional, accurate and reliable energy monitoring system as part of your ISO 50001 strategy.

SERVICES
EXPERTS

- Verification of LoRaWAN® network coverage on site.
- Commissioning of equipment.
- Verification of consistent data reporting in the EMS software.

For more information, contact your Socomec representative.omec.

Application	
	DIRIS B-10 LoRaWAN®
Metering	
± kWh, ± kvarh, kVAh	•
Multi-tariff	•
Multi-measurement	
U12, U23, U31, V1, V2, V3, f	•
U system, V system	•
I1, I2, I3, In, ΣP, ΣQ, ΣS, PF	•
P, Q, S, PF per phase	•
Predictive power	•
Phi, cos Phi, tan Phi	•
Temperatures	•
Analysis of quality	
THDv1, THDv2, THDv3, THDu12, THDu23, THDu31	•
THDi1, THDi2, THDi3, THDin	•
Voltage imbalances Ph/N and Ph/Ph	•
Current imbalances (Inba, Idir, linv, lhom, Inb)	•
Alarms	
Systems (CT disconnected, VI association, bad CT primary)	•
Protection (VirtualMonitor)	•
Logical (digital inputs)	•
Measurement	•

Accessories

Sealing kit for DIRIS B-10L

Prevents access to the cabling of the monitoring device.

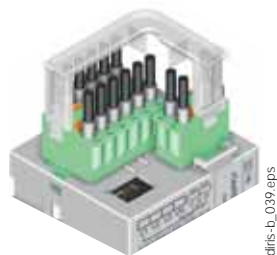

Wireless antenna kit, extended length 3 m

The antenna can be extended outside the cabinet in which the DIRIS B-10L is housed. This allows to improve the transmission range within constraining infrastructures.

USB configuration cable (2 m)

The configuration of the DIRIS B-10L is done from the Easy Config System software via a direct USB connection to a PC.

DIRIS B-10L

LoRaWAN® Power Monitoring Device

DIRIS D-30 monitor

DIRIS D-30

Connection



diris-d_001_a_1_cat



diris-b_043_b_1_x_catal

DIRIS D-30

DIRIS B-10L

Optional modules

DIRIS O



Optional module

DIRIS B-10L

diris-b_045_a_psd



diris-b_046_b_psd

Optional modules (4 max.)*

- Digital inputs/outputs
- Temperature inputs

* A maximum of 4 modules with a maximum of 1 temperature module.



diris-o_019_a

DIRIS O-iod

- 2 digital inputs enable meter impulses to be retrieved, or the uploading of information relating to the statuses of auxiliary contacts.
- 2 digital outputs can be connected to configurable alarms warning of exceeded thresholds (power, current, etc.) or can be piloted remotely.



diris-o_020_a

DIRIS O-it

- 3 temperature inputs to be connected to PT100 or PT1000 sensors.
- Ambient temperature

DIRIS B terminal strips

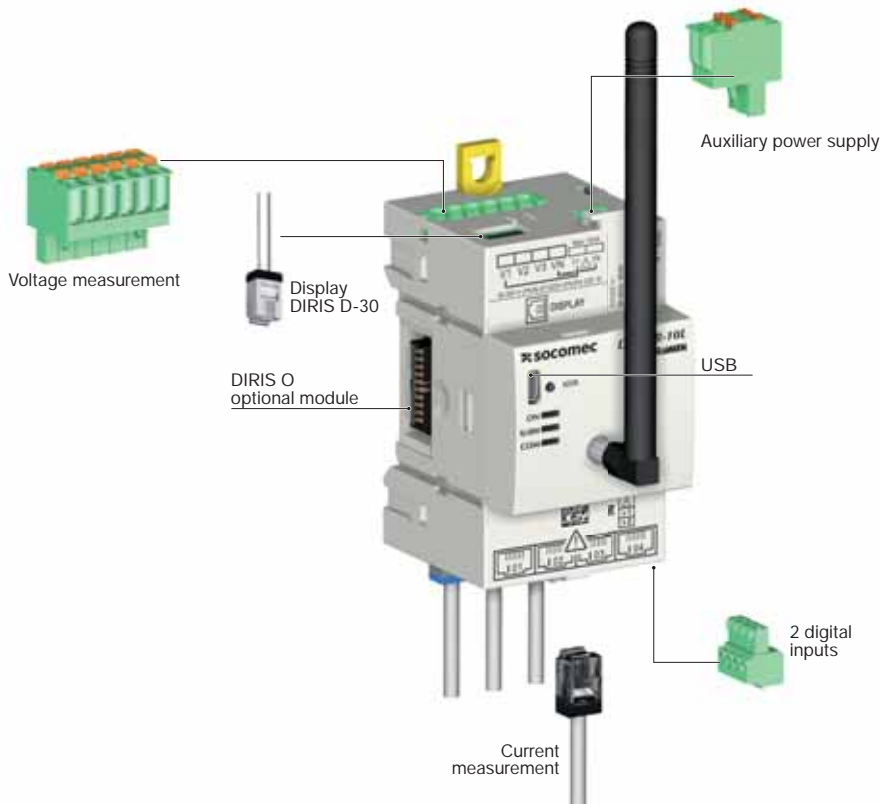

dfiris-b_050_b_1_en_cat.ai

Current measurement

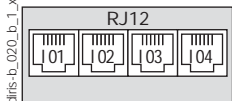

Voltage measurement and auxiliary power supply

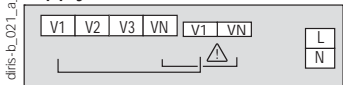

2 inputs supplied with power by the product

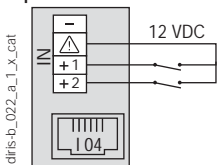

Self-powered

Scope for simplifying linking up the power supply using the measurement terminal strip (terminals provided for this purpose)

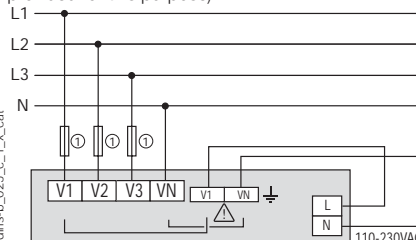

1. 0.5 A gG / 0.5 A class CC fuses.

Separate power sources

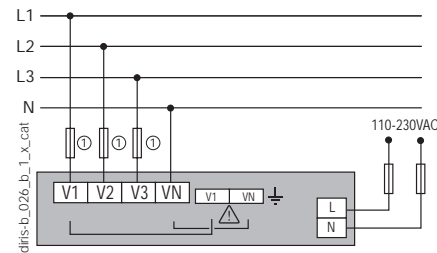

1. 0.5 A gG / 0.5 A class CC fuses.

2 inputs with an external power source

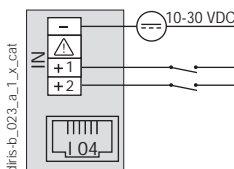

RJ9 for DIRIS D-30

(Autonomous power supply and data)



Terminals of DIRIS O optional modules

Power supply for optional modules

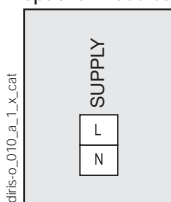

NC: not connected

DIRIS O-iod

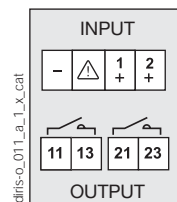

DIRIS O-it

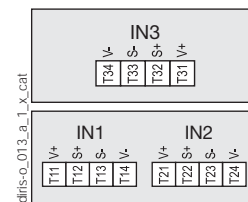

DIRIS B-10L

LoRaWAN® Power Monitoring Device

Connections

Associated current sensors

Various types of current sensors can be connected to the DIRIS B-10L: solid-core TE, split-core TR/iTR, flexible TF current sensors. This range of sensors can be adapted to all types of new or existing installations. A rapid RJ12 connection makes wiring easy and reliable and prevents wiring errors. The DIRIS B-10L automatically recognises the type of sensor used and its current rating. This guarantees the overall accuracy of the DIRIS B-10L + current sensor measurement chain. For more information: see "TE, TR/iTR, TF sensors" pages.

TE solid-core current sensors

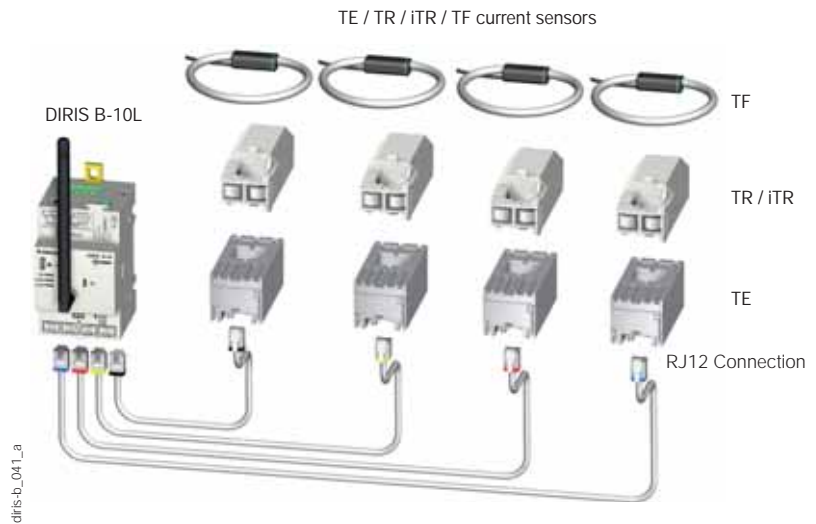
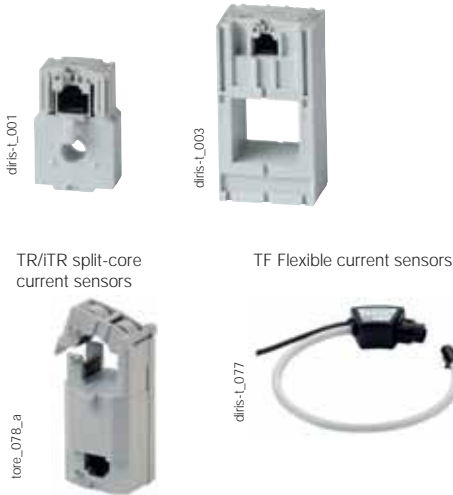

Network and connection examples

Three-phase + Neutral

3P+N - 4CT (measurement for 1 three-phase load + Neutral)

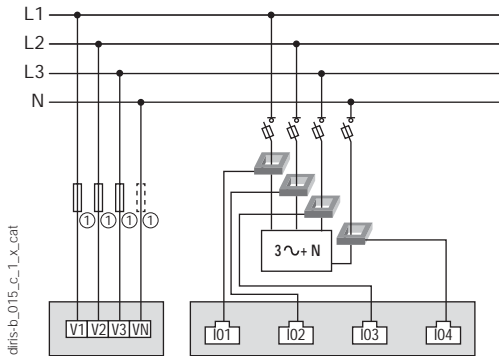

Three-phase

3P - 2CT (2 three-phase loads without neutral)

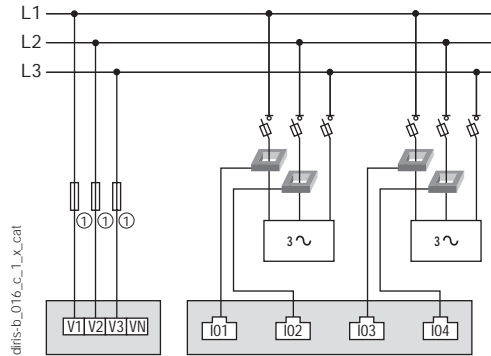

Three-phase

3P+N - 3CT & 1P+N - 1CT (1 three-phase load & 1 single-phase load)

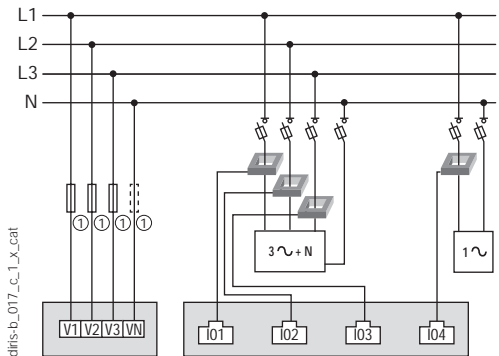

Single-phase

1P+N-1CT (4 single-phase loads)

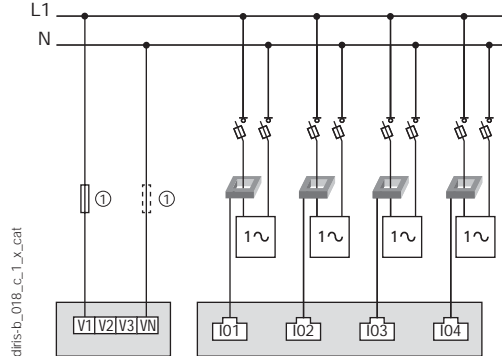

1. 0.5 A gG / 0.5 A class CC fuses.
On units with an autonomous power supply, a fuse must be added to the neutral wire.



Dimensions (mm)

DIRIS B-10L

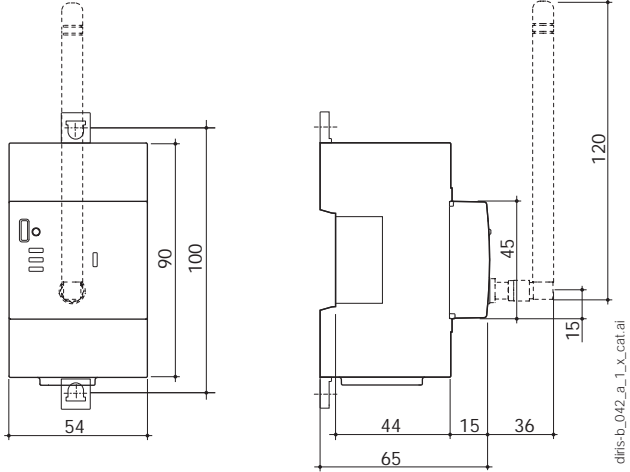

DIRIS O optional modules

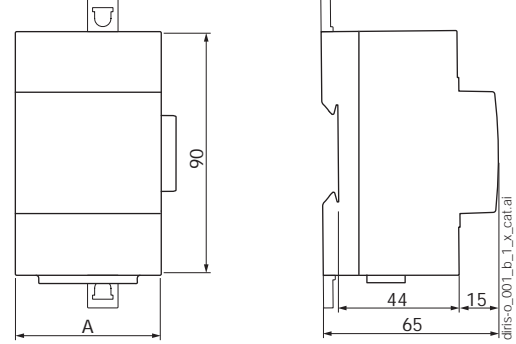

DIRIS O optional modules	A (mm)
DIRIS O-lod - DIRIS O-it	45

DIRIS D-30

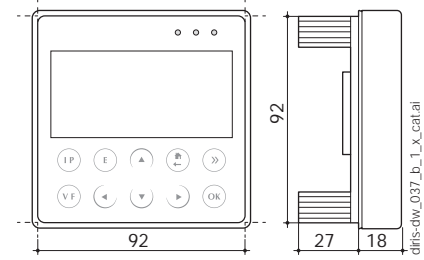

DIRIS B-10L

LoRaWAN® Power Monitoring Device

Communication architecture

Architecture of private network and local retrieval of data

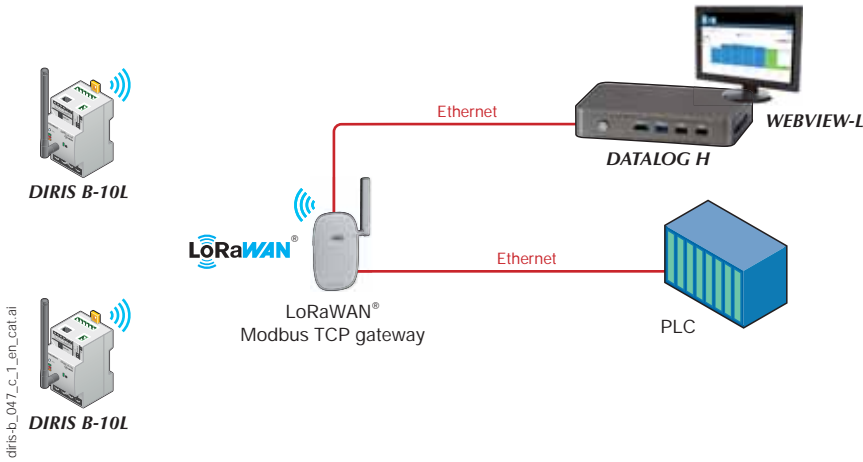

Cloud Architecture – private network

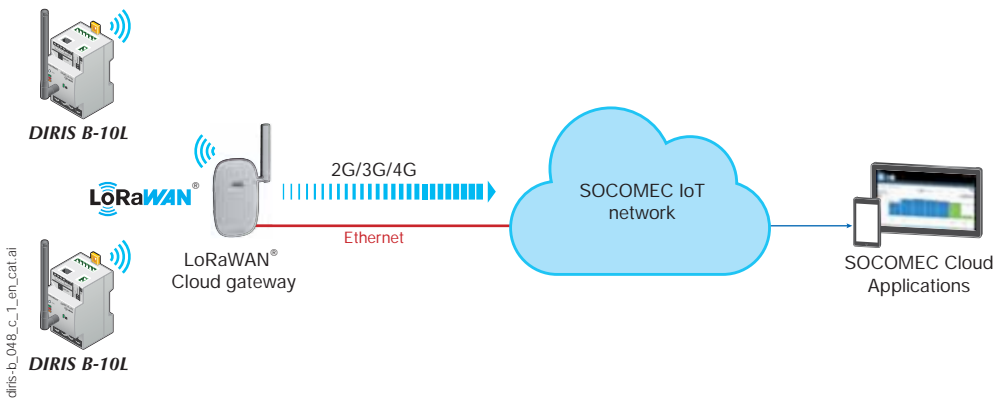

Cloud Architecture – operated network

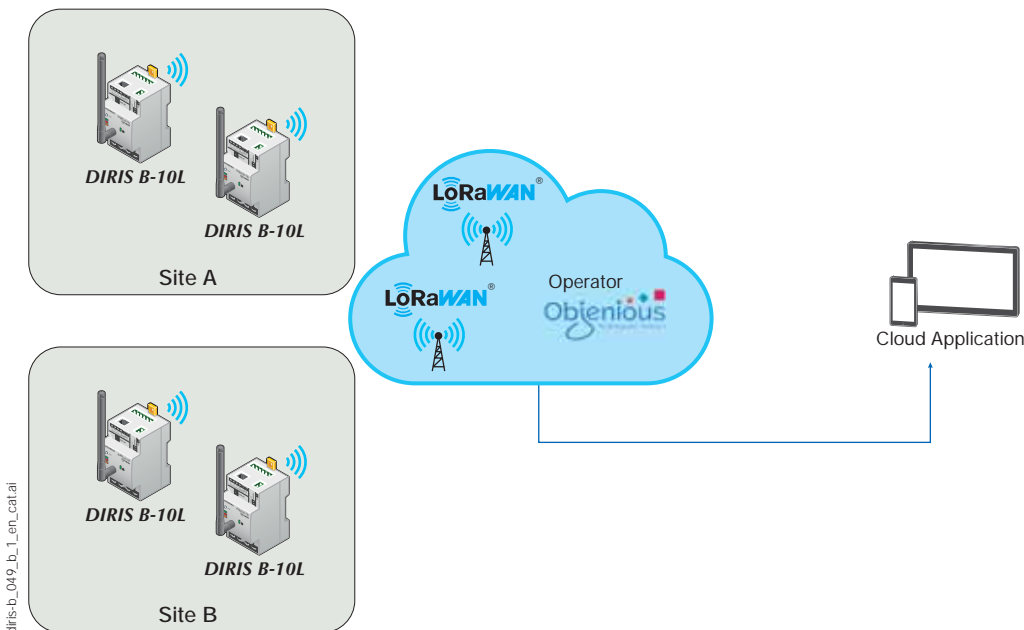

DIRIS B-10L characteristics

Electrical characteristics

Auxiliary power supply	
AC voltage	110-230 VAC ±15% (Ph/N or Ph/Ph) Cat III
Frequency	50/60 Hz
Power consumption	< 2 VA without display unit, < 6 VA with display unit
Connection	Unpluggable spring-cage terminal strip, 2 x 2 positions, rigid cable 0.5 ... 2.5 mm ² or flexible with tip 0.25 ... 1.5 mm ²

Measurement characteristics

Measurement of energy and power levels	
Accuracy	Class 0.2 DIRIS B-10L alone
Active energy and active power	Class 0.5 with TE, ITR or TF sensors Class 1 with TR sensors
Reactive energy accuracy	Class 2 with TE, TR/ITR or TF sensors

Measurement of power factor	
Accuracy	Class 0.5 with sensors TE, ITR or TF Class 1 with TR sensors

Voltage measurement	
Characteristics of the measured network	50-300VAC (Ph/N) - 87-520VAC (Ph/Ph) - CAT III
Frequency range	45 to 65Hz
Frequency accuracy	Class 0.02
Network type	Single-phase / two-phase / two-phase with neutral / 3-phase / 3-phase with neutral
Measurement by voltage transformer	Primary: 400 000 VAC Secondary: 60, 100, 110, 173, 190 VAC
Input consumption	≤ 0,1 VA
Permanent overload	300 VAC Ph/N
Accuracy of voltage measurement	Class 0.2
Connection	Pullout spring-cage terminal strip, 2 x 6 positions, rigid cable 0.5 ... 2.5 mm ² or flexible with tip 0.25 ... 1.5 mm ²

Measurement of currents	
Number of current inputs	4
Associated current sensors	Solid TE sensors, split-core TR/ITR, flexible TF
Accuracy	Class 0.2 DIRIS B-10L alone Class 0.5 with TE, ITR or TF sensors Class 1 with TR sensors
Connection	Specific Socomec cable with RJ12 connectors

Communication characteristics	
Link	Wireless radio frequency
Protocol	LoRaWAN®
Frequency range	863-870 MHz
Class	Class C
Version	1.0.3
Activation method	OTAA
Use	Europe

Environmental characteristics	
Ambient operating temperature	-10 ... +70 °C
Storage temperature	-25 ... +85 °C
Operating humidity	55 °C / 97% relative humidity
Operating altitude	< 2000 m
Vibration	1 G from 10 to 100 Hz

Characteristics of the DIRIS D-30 display unit

Mechanical characteristics	
Type of monitor	Capacitive touch-screen technology, 10 keys
Screen resolution	350 x 160 pixels
Single-product connection	
RJ9	Autonomous power supply and data
Micro-USB	Firmware Upgrade
Degree of protection	IP65 (front face)
Environment	
Storage temperature (°C)	-20 ... +70 °C
Operating temperature (°C)	-20 ... +70 °C
Humidity	95% ... 40 °C
Installation category	CAT III
Degree of pollution	2

DIRIS O optional modules characteristics

Power supply ⁽¹⁾	
AC voltage	110-230 VAC ±15%
Frequency	50/60 Hz

(1) No power supply on DIRIS O-it.

DIRIS O-iod - 2 digital inputs / 2 digital outputs	
Number of inputs	2 per optional module - max. 4 optional modules
Type	Optocoupler, internal polarisation (12 VDC ± 10%) or external (10-30 VDC ± 10%)
Function	Logical status or pulse collection
Number of outputs	2 per optional module - max. 4 optional modules
Type	Relay / 230 VAC ±15% - 1A
Function	Alarm report on digital outputs
Connection of inputs / outputs	Unpluggable screw-type terminal strip, 4 positions, rigid or flexible cable, 0.14 to 1.5 mm ²

DIRIS O-it - 3 temperature inputs	
Number of inputs	3 external inputs + 1 ambient measurement
Dynamic	-20 ... +150 °C
Type	PT100 or PT1000

References

Power Monitoring Device		Reference
DIRIS B-10L	LoRaWAN® - 230 VAC	4829 0900
DIRIS O optional modules		Reference
DIRIS O-iod	2 digital inputs/2 digital outputs	4829 0030
DIRIS O-it	3 temperature inputs PT 100 / PT 1000	4829 0032

Accessories		Reference
DIRIS D-30 - Single-point display unit		4829 0200
RJ9 cable for DIRIS D-30 monitor - 1.5 m		4829 0280
RJ9 cable for DIRIS D-30 monitor - 3 m		4829 0281
USB configuration cable		4829 0050
Remote antenna kit (antenna + 3 m extension cable + mounting bracket)		4829 0922

DIRIS Q800

Electrical network analyser

quality analysis of electrical energy and power grids



DIRIS Q800

The solution for

- > Industry
- > Infrastructure
- > Healthcare buildings
- > Data centers



Strong points

- > Large colour touchscreen
- > High performance and accuracy
- > Regulatory compliance
- > Multiple communication channels

Compliance with standards

- > IEC 61000-4-30 :2015 Ed.3 class A
- > IEC 62586-1
- > IEC 62586-2
- > IEC 62053-22
- > IEC 62053-24
- > EN 50160



Function

The **DIRIS Q800** is a multifunction network analyser for all energy efficiency projects. It helps to actively ensure the electrical system runs continuously and at optimised rates.

As such, with this system you can:

- Improve the efficiency of your facility.
- Reduce production losses.
- Optimise running costs.
- Reduce maintenance costs.

To achieve these objectives, the DIRIS Q800 does the following:

- Measures electrical parameters and status (via auxiliary contacts).
- Analyses the quality of energy according to class A IEC 61000-4-30:2015 Ed.3.
- Measures differential current.
- GPS synchronisation.
- Sends an email in the event of an alarm.

Advantages

Large colour touchscreen

The 192 x 144 mm color touchscreen is tactile, easy to operate and provides intuitive navigation.

Regulatory compliance

By its compliance with IEC 61000-4-30:2015 Ed.3 Class A for all electrical parameters and IEC 62586-2, you have the assurance of a certified and high quality product.

Multiple communication channels

With its multiple communication options, the DIRIS Q800 can be integrated into any type of communication infrastructure:

- 1 rear Ethernet port for permanent cable connection.
- 1 front Ethernet for local diagnostics.
- 1 Wifi port.
- 1 RS485 port.
- 1 USB port.
- GPS synchronisation.
- Built-in Webserver.
- Protocols: HTTP, HTTPS, FTP, NTP, MODBUS, QDIF, SMTP.

Functions

Measurements

- Measures across 4 quadrants
- Voltage by phase, current by phase, frequency.
- Neutral current, differential current.
- Neutral/earth voltage.
- Active, reactive and apparent power.
- Cos phi and power factor.
- THD and spectral analysis up to the 63rd for current and voltage.
- Flicker (Pst, Plt).
- Voltage and current unbalance.
- Remote control signals.
- Current and Power Demand: average and maximum (timestamped)

Logging

- EN 50160 events ½ period (10 ms): voltage dips, voltage cutouts, voltage surges.
- Current events 1/2 period (10 ms): inrush
- Data exported automatically via FTP.
- EN 50160 reports with CBEMA / ITIC curves for PQ events.
- Transients (20 micro seconds).

Inputs/outputs

- 4 digital inputs.
- 4 digital outputs.
- 4 analogue outputs.

Dimensions (mm)

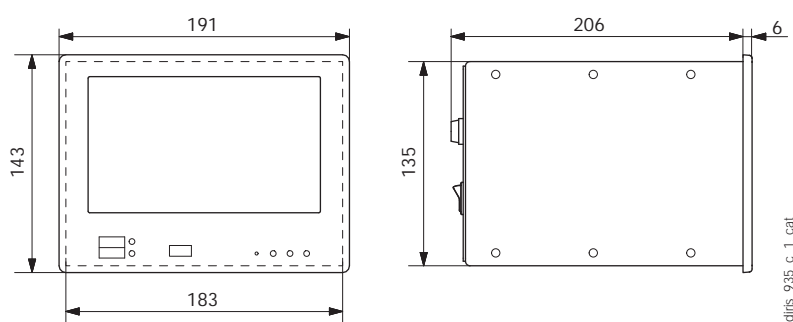

Dimensions	
Cutout	192 x 144 DIN / 186 x 138 mm
Front panel (W x H)	191 x 143 mm
Enclosures (W x H x D)	183 x 135 x 190 mm
Weight	1400 g

Specifications

Auxiliary power supply	
Voltage range	100 ... 240 VAC / 65 ... 250 VDC
Frequency	50/60 Hz
Power consumption	Max. 15 VA
Backup battery	Li-ion 2500 mAh (>15 min autonomy)
Measurement inputs	
Direct voltage measurement input	P-N: max 580 V RMS CAT III L-L: max 1000 V RMS CAT III
U4 direct voltage measurement input	Max 580 V RMS CAT II
Voltage input crest factor	2
Current inputs	Max 7 A RMS
Current input consumption	0.04 VA
Current input crest factor	3
Voltage input impedance	> 6 MΩ
Frequency range	42.5 to 57.5 Hz/51 to 69 Hz
Voltage reference channel	U1N/U12
Sampling	51.2 kHz @50 Hz
Accuracy	
Three-phase voltage	± 0.1%
4 th voltage (neutral/earth)	± 0.2%
Currents	± 0.2%
Power	± 0.2%
Frequency	± 10 mHz
Harmonics	Class 1 IEC/EN 61000-4-7
Active energy	Class 0.2S IEC/EN 62053-22
Reactive energy	Class 1 IEC/EN 62053-24

Communication	
Ethernet ports	2 Auto MDIX RJ45 10/100 Base Ethernet
RS485 opto-insulated port (slave)	0.5 UL 4800 to 115200 bps
Passive WIFI antenna	RP-SMA female
Active GPS antenna	SMA female
Protocols	HTTP, HTTPS, FTP, SFTP, NTP, NMEA, Modbus RTU/TCP, SMTP
USB port	USB 2.0
Environmental conditions	
Operating temperature (max. range)	-25 ... +55°C
Storage temperature	-25 ... +75°C
Humidity	Max. 95 %
Max. altitude	2000 m
Standards and safety	
Product conformity	IEC/EN 62586-1, IEC/EN 62586-2
Safety	EN 61010-2-030
Degree of pollution	2 (EN 61010-1)
Degree of protection	IP40 front, IP20 rear
Directive	RED §3.1a Health EN 62311 :2008 RED § 3.1b EMC

References

Designation	Reference
DIRIS Q800 100 ... 240 VAC / 65 ... 250 VDC	4826 0100 ⁽¹⁾

(1) Power supply 19 ... 60 VDC: please contact us.

DIRIS Q800

Electrical network analyser

quality analysis of electrical energy and power grids

Terminals

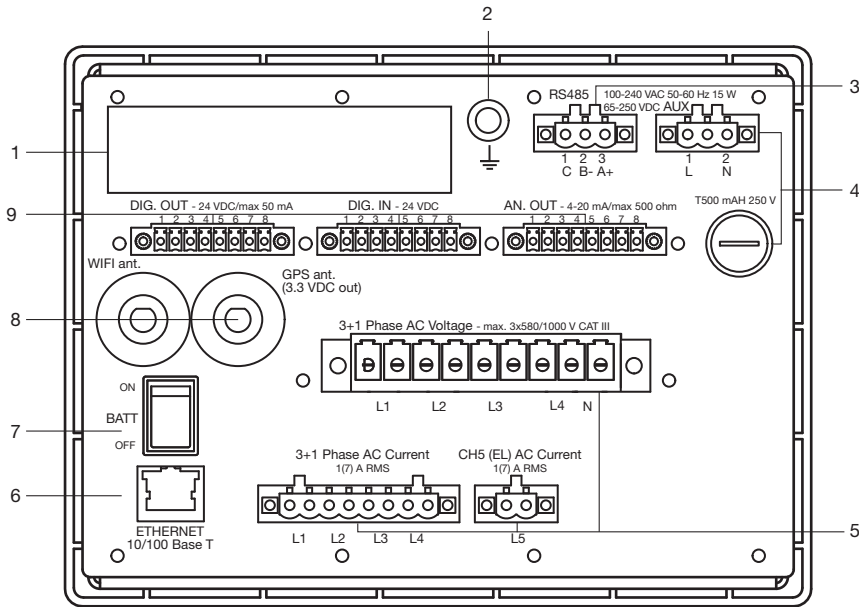

1. Product label
2. Earth connection
3. RS485 MODBUS RTU communication
4. Auxiliary power supply and fuse
5. Voltage and current inputs
6. Auto MDIX ETHERNET port
7. Battery switch
8. GPS and WIFI antenna
9. Logical outputs, analogue inputs/outputs

diris_933_a_1_x_cat

Communication via RS485 link

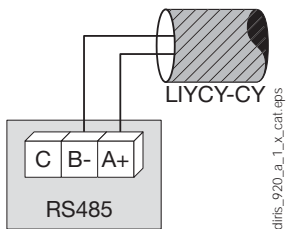

diris_920_a_1_x_cat.eps

AC and DC auxiliary power supply

100-240 VAC
65/250 VDC

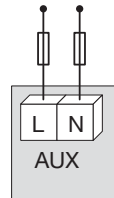

diris_921_b_1_x_cat.eps

Ethernet communication

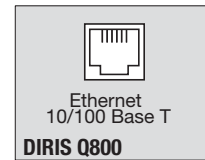

diris_928_a_1_x_cat.eps

Digital outputs

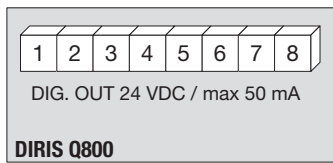

diris_922_a_1_x_cat.eps

DIRIS Q800

- 1-2: optocoupler output 1
- 3-4: optocoupler output 2
- 5-6: optocoupler output 3
- 7-8: optocoupler output 4

Digital inputs

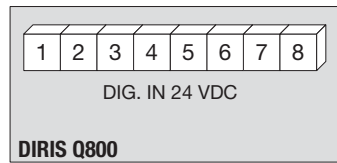

diris_923_a_1_x_cat.eps

DIRIS Q800

- 1-2: optocoupler input 1
- 3-4: optocoupler input 2
- 5-6: optocoupler input 3
- 7-8: optocoupler input 4

Analogue outputs

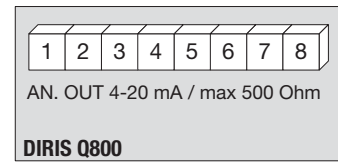

diris_924_a_1_x_cat.eps

DIRIS Q800

- 1-2: analogue output 1
- 3-4: analogue output 2
- 5-6: analogue output 3
- 7-8: analogue output 4

Current and voltage inputs

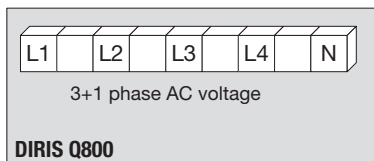

diris_925_a_1_x_cat.eps

DIRIS Q800

L1, L2, L3, L4, N: voltage inputs

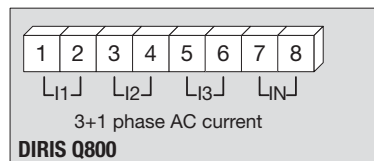

diris_926_a_1_x_cat.eps

DIRIS Q800

- 1-2: current input i1
- 3-4: current input i2
- 5-6: current input i3
- 7-8: current input iN

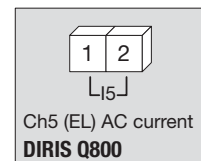

diris_927_a_1_x_cat.eps

DIRIS Q800

1-2: differential core connections

Connections

Three-phase + neutral, 4 CT + differential measurements (1/5 A)

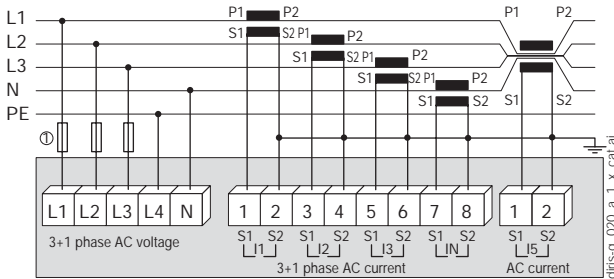

1. 0.5 A gG / 0.5 A class CC fuses.

Three-phase + neutral, 3 CT + differential measurements (1/5 A)

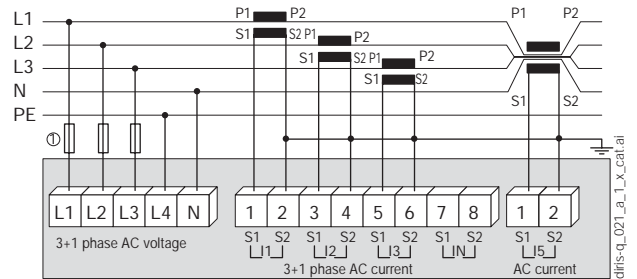

1. 0.5 A gG / 0.5 A class CC fuses.

Three-phase, 3 CT + differential measurements (1/5 A)

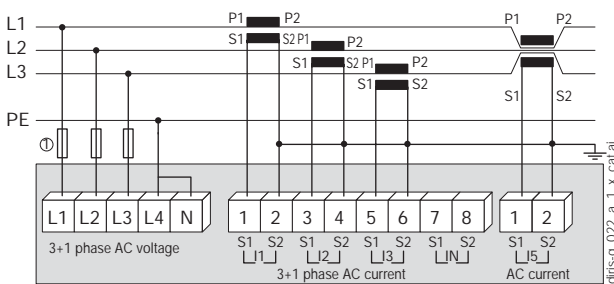

1. 0.5 A gG / 0.5 A class CC fuses.

Three-phase, 2 CT + differential measurements (1/5 A)

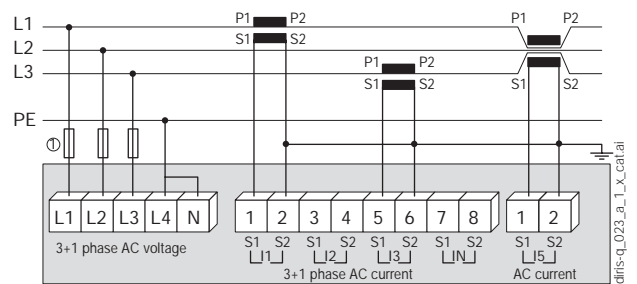

1. 0.5 A gG / 0.5 A class CC fuses.

Two-phase + neutral, 3 CT + differential measurements (1/5 A)

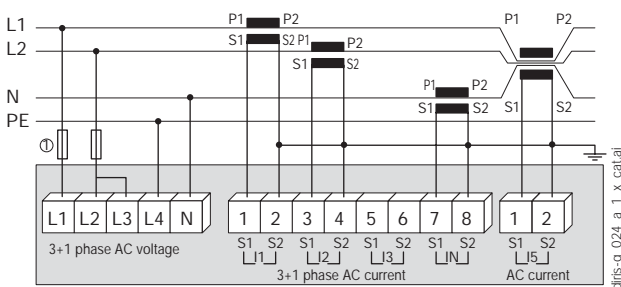

1. 0.5 A gG / 0.5 A class CC fuses.

Single-phase, 1 CT + differential measurements (1/5 A)

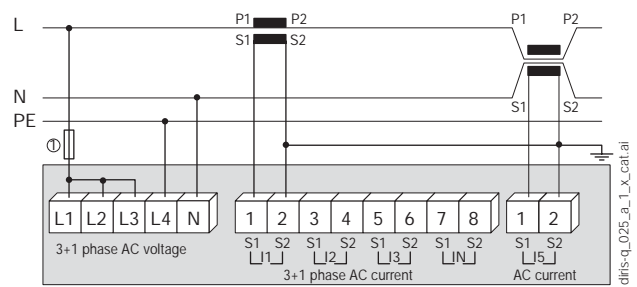

1. 0.5 A gG / 0.5 A class CC fuses.

Expert Services

- > Study, definition, advice, implementation, maintenance and training... Our experts "Expert Services" offer complete support for the success of your project.



Selection guide

Current transformers

Type	TRB 60	TRB 70	TRB 135	TCA 14	TCA 21	TCA 22	TCB 17-20	TCB 26-30	TCB 28-30	TCB 26-40	TCB 32-40	TCB 44-50
Format	Wound primary			Cable			Cable – busbar					
Class	0.5	0.5	0.5	1	0.5/1	1	1	0.5/1	0.5/1	1	0.5/1	0.5/1
Version 0.2s			(1)			(2)		T2CB 26-30			T2CB 32-40	
	<i>p. 409</i>			<i>p. 411</i>			<i>p. 412</i>					

Rating (A)

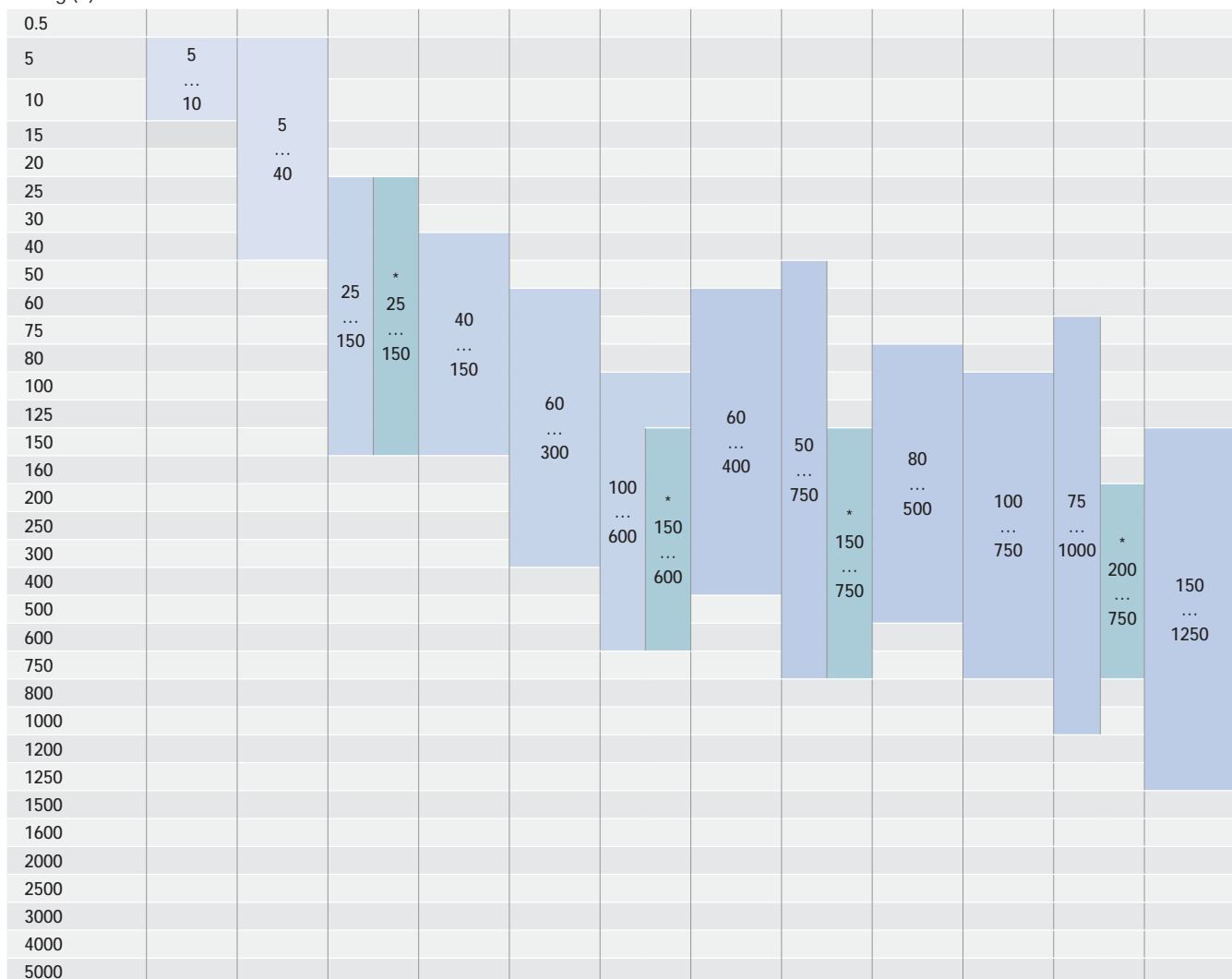

Dimensions

Height	75.5	85.5	85	65	65	65	65	61	70	75.5	88.5	98.5
Width	61	71	135	45	45	49.5	49.5	75.5	49.9	61	71	86
Depth	35	45	60	30	30	35	50	48	68	48	58	58
Cable (Ø mm)				14	21	22.5	17.5	26	28	26	32	44
Busbar 1							20x5	30x10	30x10	32x18	40x10	50x12
Busbar 2								20x10 (x2)		40x12	30x5 (x2)	40x10 (x2)
Busbar 3												

* Class 1.

(1) See T2RB 115 for a 0.2S wound primary version. Dimensions differ from TRB 135.

(2) See T2CA 225 for a 0.2S closed-loop cable version. Dimensions differ from TCA 22.

TCB 44-63	TCB 55-80	TCD 85-100	TCB 100-125	TBA 60	TBA 80	TBA 100	TBA 103	TBA 127	T0 23	T0 58	T0 812	T0 816
Cable – busbar				Busbar					Split-core			
0.5	0.5	0.5	0.5	0.5/1	0.5	0.5	0.5	0.5	1/3	0.5/1	0.5/1	0.5
T2CB 44-63						T2BA 100	T2BA 103	T2BA 127				
<i>p. 413</i>				<i>p. 416</i>					<i>p. 420</i>			

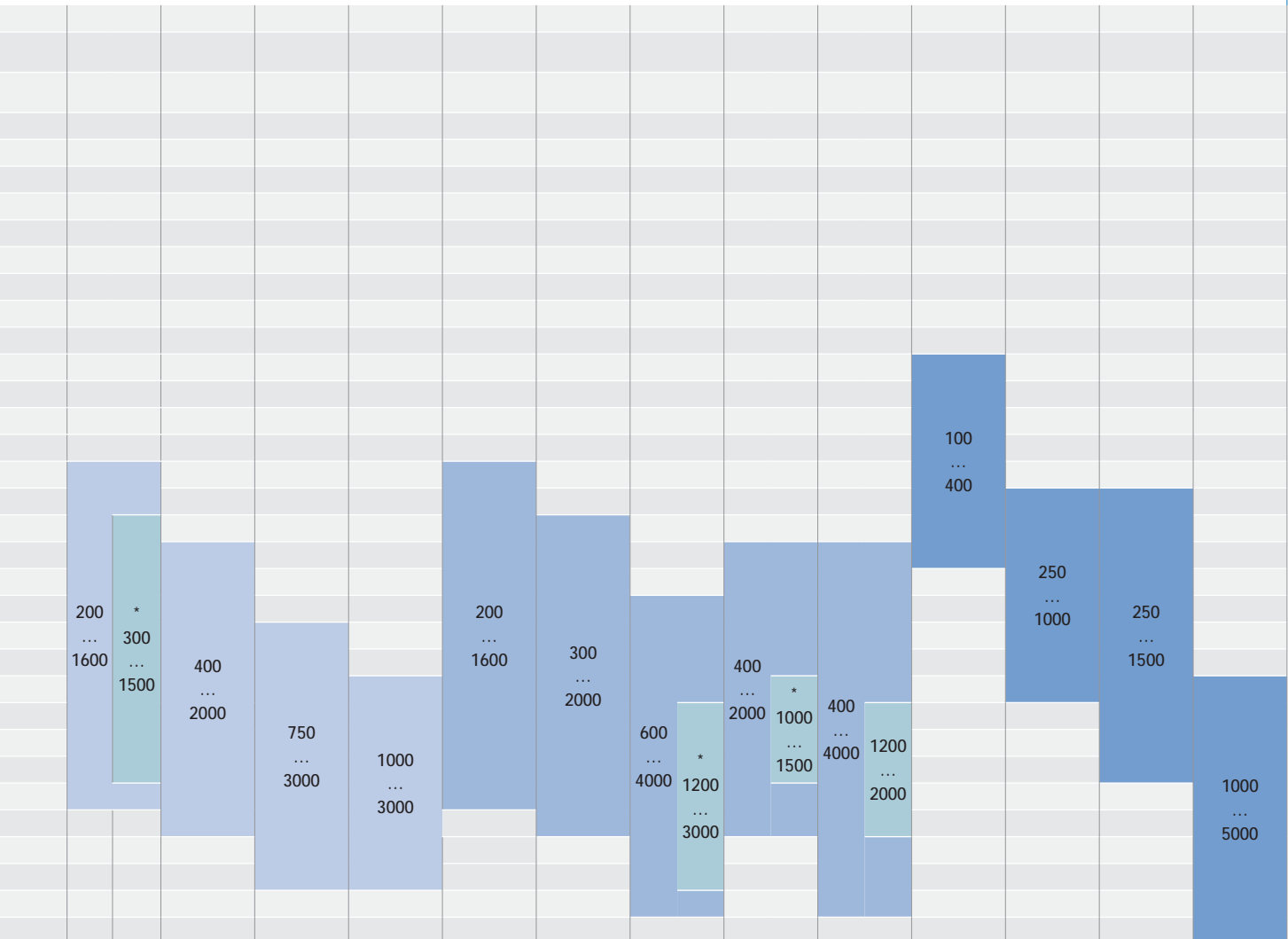

105.5	123.5	184.8	184.8	129	117	167	150	175	106	158	198	243
96	120	172	172	88	96	129	99	100	93	125	155	195
58	58	52	52	48	68	78	58	55	58	58	58	79
44	55	85	100									
63x10	80x10	100x10	123x30	60x30	84x34	100x55	103x41	128x38	33x23	85x55	125x85	165x85
50x10 (x2)	60x30 60x10 (x2)	80x10 (x3)	100x10 (x3)									

Current transformers

Measurement devices

from 5 to 5000 A



Three-phase CT

Bar-through CT

Split-core transformer

Cable-through CT

The solution for

- > Industry
- > Office buildings



Strong points

- > An adapted accuracy class
- > A wide range of ratings and dimensions
- > Quick and easy to mount

Conformity to standards

- > IEC 61869-2
- > IEC 61439-1



Available on request

SOCOMECC also offer customised solutions:

- > 1 A secondary
- > Double or triple primary ratio
- > Voltage transformer
- > Summation CTs

Function

SOCOMECC current transformers deliver to the secondary a standard current proportional to the primary current and adapted to the rating of the associated device. They are equipped as standard with removable terminal covers and double terminals allowing the secondary to be short-circuited without any risk.

They are mounted using two screw-on metal brackets or, in certain cases, by a clip-on DIN-rail fastener. The connections are made by screws or by fast-on terminals.

- Accuracy class: 0.2s — 0.5 or 1.
- Dielectric quality: 3 kV — 50 Hz — 1 min.
- Operating frequency: 50 — 60 Hz.
- Permanent overload: 1.2 In.
- Insulation class: E (120 °C).

Advantages

An adapted accuracy class

In order to get the best of your DIRIS multifunction meters and COUNTIS energy meters, we can provide current transformers with the following accuracy classes: 0.2s; 0.5; 1 or 3.

A wide range of ratings and dimensions

Your measurement process can be optimised whatever your needs in terms of ratings, space requirements, conductor sizing or accuracy class. A wide range of combinations are available in our standard range with specific versions available on request (other ratios, tropicalisation and specific frequency, class or burden).

Quick and easy to mount

Our current transformers are adapted to any type of mounting: edgewise or flat mounting, DIN-rail or back-plate mounting. Implementation is easy and rapid.

Composition of the range

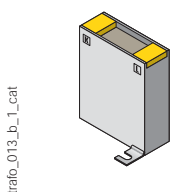

Primary wound moulded case CT

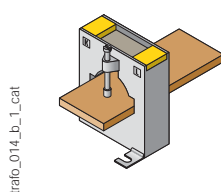

Bar or cable-through CT

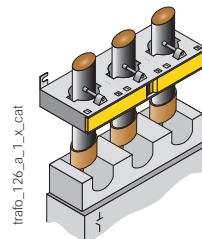

Bar or cable-through three-phase CT

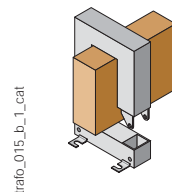

Bar-through split-core CT

Primary wound moulded case CT

References

Primary	Secondary ⁽¹⁾	TRB 60		TRB 70		T2RB 115		TRB 135	
		Class 0.5	Reference	Class 0.5	Reference	Class 0.2s	Reference	Class 0.5	Reference
5 A	5 A	2.5 VA	192T 0505	10 VA	192T 0521				
10 A	5 A	2.5 VA	192T 0510	10 VA	192T 0522				
15 A	5 A			10 VA	192T 0523				
20 A	5 A			10 VA	192T 0524				
25 A	5 A			10 VA	192T 0525	7.5 VA	192U 0402	10 VA	192T 0603
30 A	5 A			5 VA	192T 0530	7.5 VA	192U 0403	10 VA	192T 0607
40 A	5 A			5 VA	192T 0541	7.5 VA	192U 0404	10 VA	192T 0604
50 A	5 A			5 VA	192T 0551	7.5 VA	192U 0405	10 VA	192T 0605
60 A	5 A					7.5 VA	192U 0406	10 VA	192T 0606
75 A	5 A					7.5 VA	192U 0407	10 VA	192T 0608
80 A	5 A					7.5 VA	192U 0408	10 VA	192T 0609
100 A	5 A							10 VA	192T 0610
125 A	5 A					7.5 VA	192U 0412	10 VA	192T 0612
150 A	5 A					7.5 VA	192U 0415	10 VA	192T 0615

(1) Secondary 1 A: on request.

Accessories

Accessories	TRB 60 Reference	TRB 70 Reference	TRB 135 Reference
DIN-rail mounting	192T 0003	192T 0005 ⁽¹⁾	
Sealable cover	192T 0105	192T 0103	192T 0101 ⁽²⁾

(1) For 40 and 50 A ratings, use reference 192T 0008.

(2) For 125 and 150 A ratings, use reference 192T 0103.

CT Plug-in transducer (CEA-VA)

Power supply	Output	TRB 60 Reference	TRB 70 Reference
Self-supplied	0-20 mA / 0-10 VDC	192Y 0015	192Y 0025 ⁽¹⁾
230 VAC	0-20 mA / 0-10 VDC	192Y 0215	192Y 0225 ⁽¹⁾
24 VDC	0-20 mA / 0-10 VDC	192Y 0115	192Y 0125 ⁽¹⁾

(1) Not available for 40 and 50 A ratings.

CT Plug-in transducer (CEA-VA4)

Power supply	Output	TRB 60 Reference	TRB 70 Reference
230 VAC	4-20 mA / 0-10 VDC	192T 0255	192Y 0265 ⁽¹⁾
24 VDC	4-20 mA / 0-10 VDC	192Y 0155	192Y 0165 ⁽¹⁾

(1) Not available for 40 and 50 A ratings.

Certificate of performance

Each class 0.2s current transformer is supplied with an individual certificate of performance, attesting to its accuracy.

Current transformers

Measurement devices

from 5 to 5000 A

Primary wound moulded case CT (continued)

Dimensions (mm)

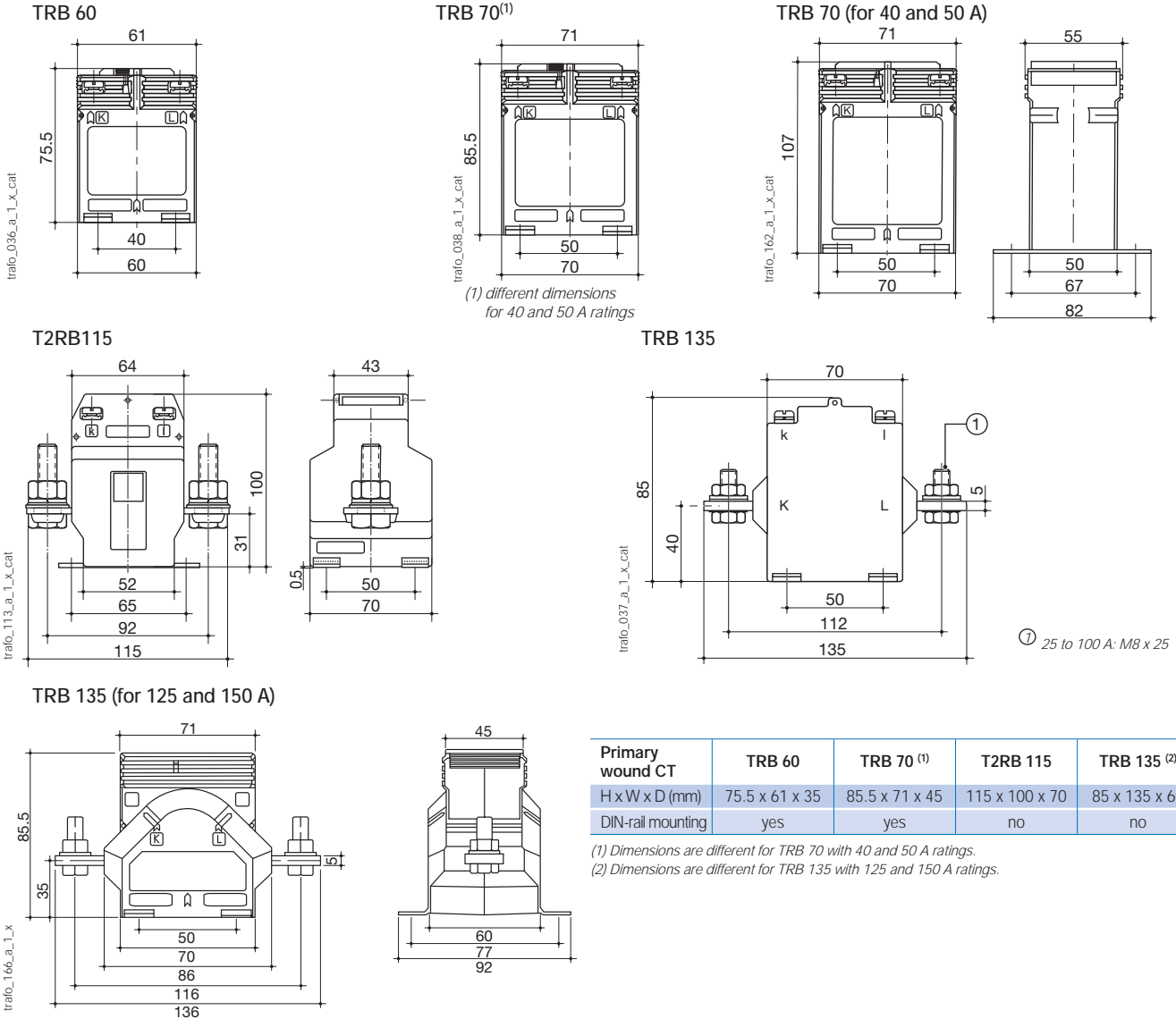

Primary wound CT	TRB 60	TRB 70 ⁽¹⁾	T2RB 115	TRB 135 ⁽²⁾
H x W x D (mm)	75.5 x 61 x 35	85.5 x 71 x 45	115 x 100 x 70	85 x 135 x 60
DIN-rail mounting	yes	yes	no	no

(1) Dimensions are different for TRB 70 with 40 and 50 A ratings.
 (2) Dimensions are different for TRB 135 with 125 and 150 A ratings.

Associated transducers



Transducer to be associated with adapted current transformers:

- Class 0.5.
- Input: 1 or 5 A.
- Output:
 - 0-20 mA, 0-10 V (type CEA-VA)
 - 4-20 mA, 0-10 V (type CEA-VA4)
- Self-supplied or auxiliary power supply 24 VDC or 230 VAC.
- 3 sizes according to the CT: type 1, 2 or 3.

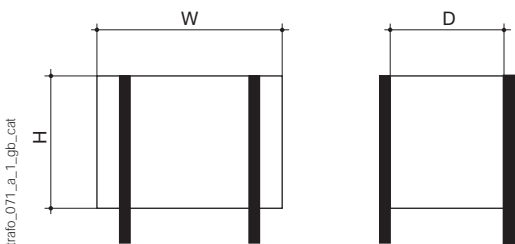
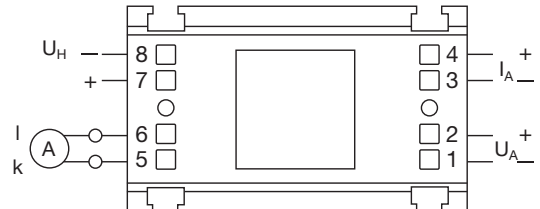

Dimensions (mm)

Converter	For CT	Height (mm)	Width (mm)	Depth (mm)
Type 1	TRB 60	50.5	60	32.5
Type 2	TRB 70	50	70	43

Cable-through CT

References

Primary	Secondary ⁽¹⁾	TCA 14		TCA 21		TCA 22		T2CA 225		
		Class 1	Reference	Class 1	Class 0.5	Reference	Class 1	Reference	Class 0.2s	Reference
40 A	5 A	1	192T 1404							
50 A	5 A	1	192T 1405							
60 A	5 A	1.5	192T 1406	1 VA		192T 2006				
75 A	5 A	1.5	192T 1407	1.5 VA		192T 2007				
80 A	5 A			1.5 VA		192T 2008				
100 A	5 A	2.5	192T 1410		1.5 VA	192T 2010	1 VA	192T 2022		
125 A	5 A	2.5	192T 1412		1.5 VA	192T 2012				
150 A	5 A	2.5	192T 1415		1.5 VA	192T 2015	1.5 VA	192T 2023	1.5 VA	192U 2215
200 A	5 A				2.5 VA	192T 2020	2.5 VA	192T 2024	2.5 VA	192U 2220
250 A	5 A				2.5 VA	192T 2016	3.75 VA	192T 2025	5 VA	192U 2225
300 A	5 A				2.5 VA	192T 2017	3.75 VA	192T 2030	5 VA	192U 2230
400 A	5 A						5 VA	192T 2034	5 VA	192U 2240
500 A	5 A						5 VA	192T 2035 ⁽²⁾	10 VA	192U 2250
600 A	5 A						5 VA	192T 2036 ⁽²⁾	10 VA	192U 2260

(1) Secondary 1 A: on request.

(2) Dimensions of T2CA 225

Accessories

Accessories	TCA 14 Reference	TCA 21 Reference	TCA 22 Reference	T2CA 225 Reference
DIN-rail mounting	192T 0006	192T 0006	192T 0007	192T 0003
Guide tube Ø 8.5 mm ⁽¹⁾		192T 0020		
Guide tube Ø 12.5 mm ⁽¹⁾		192T 0021	192T 0023	
Guide tube Ø 16.5 mm ⁽¹⁾			192T 0024	
Sealable cover				192T 0105

(1) For centralising cables within the CT aperture.

Dimensions (mm)

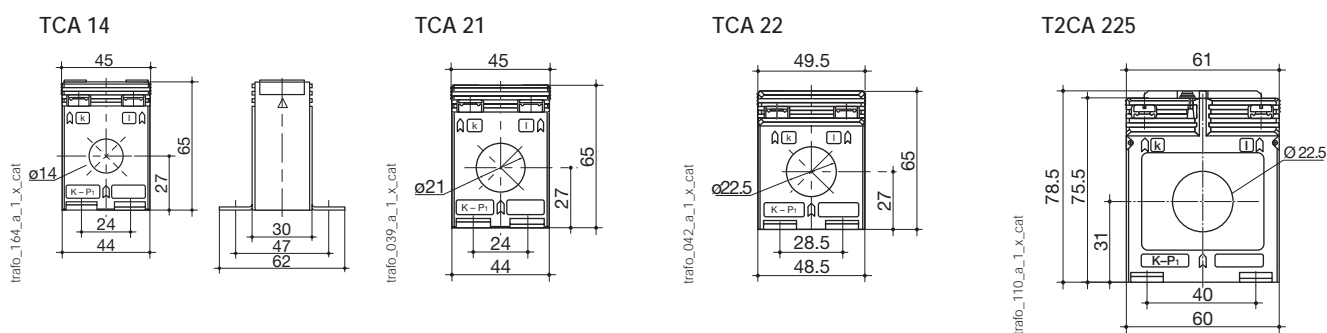

Cable-through CT	TCA 14	TCA 21	TCA 22 ⁽¹⁾	T2CA 225
Ø cable (mm)	14	21	22.5	22.5
H x W x D (mm)	65 x 45 x 30	65 x 45 x 30	65 x 49.5 x 35	78.5 x 61 x 35
DIN-rail mounting	yes	yes	yes	yes

(1) Dimensions are different for 600 A: 78.5x61x35.

Current transformers

Measurement devices

from 5 to 5000 A

Bar or cable-through CT

References

Primary	Secondary ⁽¹⁾	TCB 17-20		TCB 26-30		T2CB 26-30		TCB 28-30			
		Class 1	Reference	Class 0.5	Class 1	Reference	Class 0.2s	Reference	Class 0.5	Class 1	Reference
50 A	5 A				1 VA	192T 2305					
60 A	5 A	1 VA	192T 2106		1 VA	192T 2306					
75 A	5 A	1 VA	192T 2107		1.5 VA	192T 2307					
80 A	5 A	1.25 VA	192T 2108		1.5 VA	192T 2308				1.25 VA	192T 2408
100 A	5 A	1.5 VA	192T 2110	1.5 VA		192T 2310				1.5 VA	192T 2410
125 A	5 A	1.5 VA	192T 2112	1.5 VA		192T 2312				2.5 VA	192T 2412
150 A	5 A	2.5 VA	192T 2115	1.5 VA		192T 2315	1.5 VA	192U 2315		2.5 VA	192T 2415
160 A	5 A	2.5 VA	192T 2116								
200 A	5 A	2.5 VA	192T 2120	2.5 VA		192T 2320	2.5 VA	192U 2320	2.5 VA		192T 2420
250 A	5 A	5 VA	192T 2125	5 VA		192T 2325	2.5 VA	192U 2325	2.5 VA		192T 2425
300 A	5 A	5 VA	192T 2130	5 VA		192T 2330	5 VA	192U 2330	2.5 VA		192T 2430
400 A	5 A	5 VA	192T 2140	5 VA		192T 2340	5 VA	192U 2340	5 VA		192T 2440
500 A	5 A			5 VA		192T 2350	5 VA	192U 2350	5 VA		192T 2450
600 A	5 A			5 VA		192T 2360	5 VA	192U 2360			
750 A	5 A			5 VA		192T 2375	5 VA	192U 2375			

(1) Secondary 1 A: on request.

Primary	Secondary ⁽¹⁾	TCB 26-40		TCB 32-40		T2CB 32-40		
		Class 1	Reference	Class 0.5	Class 1	Reference	Class 0.2s	Reference
75 A	5 A				1.5 VA	192T 4007		
100 A	5 A	1.5 VA	192T 3210	1.5 VA		192T 4010		
125 A	5 A	2.5 VA	192T 3212	1.5 VA		192T 4012		
150 A	5 A	2.5 VA	192T 3215	2.5 VA		192T 4015		
160 A	5 A	2.5 VA	192T 3216					
200 A	5 A	2.5 VA	192T 3220	5 VA		192T 4020	2.5 VA	192U 4020
250 A	5 A	2.5 VA	192T 3225	5 VA		192T 4025	5 VA	192U 4025
300 A	5 A	5 VA	192T 3230	10 VA		192T 4030	5 VA	192U 4030
400 A	5 A	5 VA	192T 3240	10 VA		192T 4040	5 VA	192U 4040
500 A	5 A	5 VA	192T 3250	10 VA		192T 4050	5 VA	192U 4050
600 A	5 A	5 VA	192T 3260	10 VA		192T 4060	5 VA	192U 4060
750 A	5 A	10 VA	192T 3275	10 VA		192T 4075	5 VA	192U 4075
800 A	5 A			10 VA		192T 4080		
1000 A	5 A			10 VA		192T 4090		

(1) Secondary 1 A: on request.

Accessories

Accessories	TCB 17-20 Reference	TCB 26-30 Reference	TCB 26-40 Reference	TCB 32-40 Reference
DIN-rail mounting	192T 0007	192T 0003	192T 0003	192T 0005
Sealable cover		192T 0105	192T 0105	192T 0103

CT Plug-in transducer (CEA-VA)

Power supply	Output	TCB 26-30 Reference	TCB 26-40 Reference	TCB 32-40 Reference
Self-supplied	0-20 mA / 0-10 VDC	192Y 0015	192Y 0015	192Y 0035
230 VAC	0-20 mA / 0-10 VDC	192Y 0215	192Y 0215	192Y 0235
24 VDC	0-20 mA / 0-10 VDC	192Y 0115	192Y 0115	192Y 0135

CT Plug-in transducer (CEA-VA4)

Power supply	Output	TCB 26-30 Reference	TCB 26-40 Reference	TCB 32-40 Reference
230 VAC	4-20 mA / 0-10 VDC	192T 0255	192T 0255	192Y 0275
24 VDC	4-20 mA / 0-10 VDC	192Y 0155	192Y 0155	192Y 0175

References

Primary	Secondary ⁽¹⁾	TCB 44-50		TCB 44-63		T2CB 44-63	
		Class 0.5	Reference	Class 0.5	Reference	Class 0.2s	Reference
150 A	5 A	1.5 VA	192T 5015				
200 A	5 A	2.5 VA	192T 5020	1.5 VA	192T 6420		
250 A	5 A	5 VA	192T 5025	1.5 VA	192T 6425		
300 A	5 A	5 VA	192T 5030	2.5 VA	192T 6430	5 VA	192U 6430
400 A	5 A	10 VA	192T 5040	5 VA	192T 6440	5 VA	192U 6440
500 A	5 A	10 VA	192T 5050	10 VA	192T 6450	10 VA	192U 6450
600 A	5 A	10 VA	192T 5060	10 VA	192T 6460	10 VA	192U 6460
750 A	5 A	10 VA	192T 5075	10 VA	192T 6475	10 VA	192U 6475
800 A	5 A	15 VA	192T 5080	10 VA	192T 6480		
1000 A	5 A	15 VA	192T 5090	15 VA	192T 6490	10 VA	192U 6490
1200 A	5 A	15 VA	192T 5092	15 VA	192T 6492	10 VA	192U 6492
1250 A	5 A	15 VA	192T 5095	15 VA	192T 6493	10 VA	192U 6493
1500 A	5 A			15 VA	192T 6495	10 VA	192U 6495
1600 A	5 A			15 VA	192T 6494		

(1) Secondary 1 A: on request.

Primary	Secondary ⁽¹⁾	TCB 55-80		TCB 85-100		TCB 100-125	
		Class 0.5	Reference	Class 0.5	Reference	Class 0.5	Reference
400 A	5 A	2.5 VA	192T 8140				
500 A	5 A	5 VA	192T 8150				
600 A	5 A	5 VA	192T 8160				
750 A	5 A	10 VA	192T 8175	2.5 VA	192T 9675		
800 A	5 A	10 VA	192T 8180	5 VA	192T 9680		
1000 A	5 A	15 VA	192T 8190	10 VA	192T 9690	5 VA	192T 9590
1200 A	5 A	15 VA	192T 8192	10 VA	192T 9692		
1250 A	5 A	15 VA	192T 8193	15 VA	192T 9693	10 VA	192T 9593
1500 A	5 A	15 VA	192T 8195	15 VA	192T 9695	15 VA	192T 9595
1600 A	5 A	15 VA	192T 8194	15 VA	192T 9694		
2000 A	5 A	15 VA	192T 8196	30 VA	192T 9696	30 VA	192T 9596
2500 A	5 A			30 VA	192T 9697	30 VA	192T 9597
3000 A	5 A			30 VA	192T 9698	30 VA	192T 9598

(1) Secondary 1 A: on request.

Accessories

Accessories	TCB 44-50 Reference	TCB 44-63 Reference	TCB 55-80 Reference	TCB 85-100 Reference	TCB 100-125 Reference
Sealable cover	192T 0102	192T 0102	192T 0102	192T 0106	192T 0106

CT Plug-in transducer (CEA-VA)

Power supply	Output	TCB 44-50 Reference	TCB 44-63 Reference	TCB 55-80 Reference
Self-supplied	0-20 mA / 0-10 VDC		192Y 0045	192Y 0045
230 VAC	0-20 mA / 0-10 VDC		192Y 0245	192Y 0245
24 VDC	0-20 mA / 0-10 VDC		192Y 0145	192Y 0145

CT Plug-in transducer (CEA-VA4)

Input	Output	TCB 44-50 Reference	TCB 44-63 Reference	TCB 55-80 Reference
230 VAC	4-20 mA / 0-10 VDC		192Y 0285	192Y 0285
24 VDC	4-20 mA / 0-10 VDC		192Y 0185	192Y 0185

Current transformers

Measurement devices

from 5 to 5000 A

Bar or cable-through CT (continued)

Dimensions (mm)

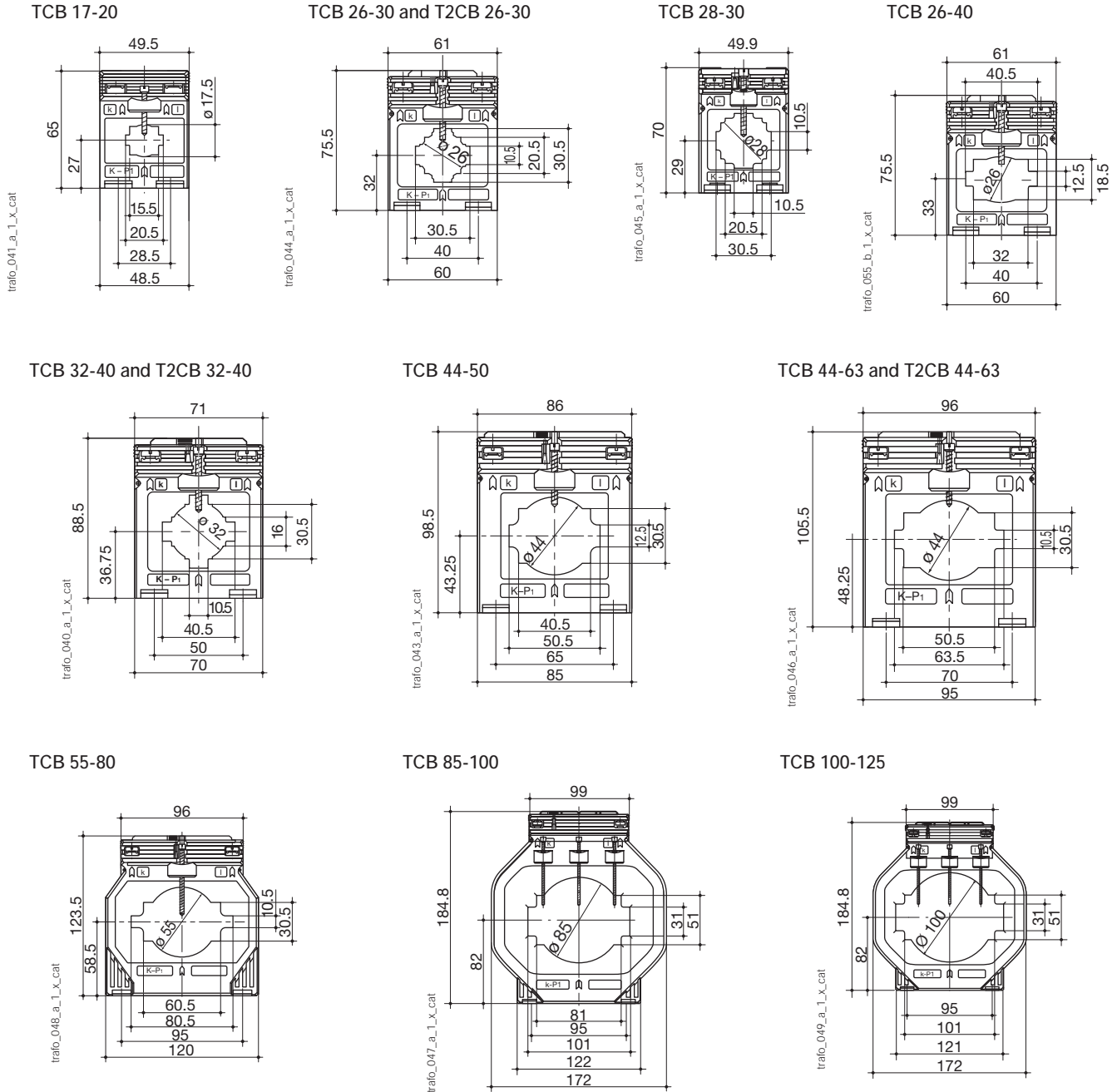

Bar or cable-through CT	TCB 17-20	TCB 26-30	T2CB 26-30	TCB 26-40	TCB 28-30	TCB 32-40	T2CB 32-40
Bar (mm)	20 x 5 (x 1)	30 x 10 (x 1) / 20 x 10 (x 1...2)	30 x 10 (x 1) / 20 x 10 (x 1...2)	40 x 12 (x 1) / 32 x 18 (x 1)	30 x 10 (x 1)	40 x 10 (x 1) / 30 x 5 (x 1...2)	40 x 10 (x 1) / 30 x 5 (x 1...2)
ϕ cable (mm)	17.5	26	26	26	28	32	32
H x W x D (mm)	65 x 49.5 x 50	75.5 x 61 x 48	75.5 x 61 x 48	75.5 x 61 x 48	70 x 49.9 x 68	88.5 x 71 x 58	88.5 x 71 x 58
DIN-rail mounting	yes	yes	yes	yes		yes	yes

Bar or cable-through CT	TCB 44-50	TCB 44-63	T2CB 44-63	TCB 55-80	TCB 85-100	TCB 100-125
Bar (mm)	50 x 12 (x 1) / 40 x 10 (x 1...2)	63 x 10 (x 1) / 50 x 10 (x 1...2)	63 x 10 (x 1) / 50 x 10 (x 1...2)	80 x 10 (x 1) / 60 x 30 (x 1) / 60 x 10 (x 1...2)	100 x 10 (x 1...2) / 80 x 10 (x 1...3)	123 x 30 (x 1) / 100 x 10 (x 1...3)
ϕ cable (mm)	44	44	44	55	85	100
H x W x D (mm)	98.5 x 86 x 58	105.5 x 96 x 58	105.5 x 96 x 58	123.5 x 120 x 58	184.5 x 172 x 52	184.5 x 172 x 52

Associated transducers

trafo_074



Transducer to be associated with adapted current transformers:

- Class 0.5
- Input: 1 or 5 A
- Output:
 - 0-20 mA, 0-10 V (model CEA-VA),
 - 4-20 mA, 0-10 V (model CEA-VA4),
- Self-supplied or auxiliary power supply 24 VDC or 230 VAC.
- 3 sizes according to the CT: type 1, 2 or 3.

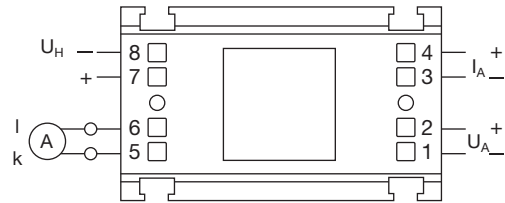

trafo_060_a_1_x_cat

trafo_071_a_1_gb_cat

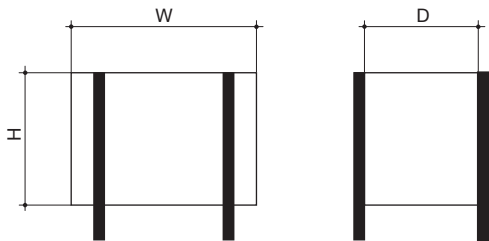

Dimensions (mm)

Converter	For CT	Height (mm)	Width (mm)	Depth (mm)
Type 1	TCB 26-30	50.5	60	32.5
Type 1	TCB 26-40	50.5	60	32.5
Type 2	TCB 32-40	50	70	43
Type 3	TCB 44-63	50.5	95	43
Type 3	TCB 55-80	50.5	95	43

Current transformers

Measurement devices

from 5 to 5000 A

Bar-through CT

References

Primary	Secondary	TBA 60			TBA 80		TBA 100		T2BA 100	
		Class 0.5	Class 1	Reference	Class 0.5	Reference	Class 0.5	Reference	Class 0.2s	Reference
200 A	5 A		2.5 VA	192T 7020						
250 A	5 A	2.5 VA		192T 7025						
300 A	5 A	2.5 VA		192T 7030	2.5 VA	192T 7530				
400 A	5 A	5 VA		192T 7040	5 VA	192T 7540				
500 A	5 A	5 VA		192T 7050	5 VA	192T 7550				
600 A	5 A	10 VA		192T 7060	5 VA	192T 7560	5 VA	192T 8060		
750 A	5 A	10 VA		192T 7075	5 VA	192T 7575	5 VA	192T 8075		
800 A	5 A	10 VA		192T 7080	10 VA	192T 7580	5 VA	192T 8080		
1000 A	5 A	15 VA		192T 7090	15 VA	192T 7590	5 VA	192T 8090		
1200 A	5 A	15 VA		192T 7092	15 VA	192T 7592	10 VA	192T 8092	5 VA	192U 8092
1250 A	5 A	15 VA		192T 7093	15 VA	192T 7593	10 VA	192T 8093	5 VA	192U 8093
1500 A	5 A	15 VA		192T 7095	15 VA	192T 7595	15 VA	192T 8095	5 VA	192U 8095
1600 A	5 A	15 VA		192T 7094	15 VA	192T 7594	15 VA	192T 8094		
2000 A	5 A				15 VA	192T 7596	15 VA	192T 8096	5 VA	192U 8096
2500 A	5 A						30 VA	192T 8097	10 VA	192U 8097
3000 A	5 A						30 VA	192T 8098 ⁽¹⁾	10 VA	192U 8098
4000 A	5 A						30 VA	-		

(1) Dimensions are different for TBA 100 with 3000 and 4000 A primary.

Primary	Secondary	TBA 103		T2BA 103		TBA 127		T2BA 127	
		Class 0.5	Reference	Class 0.2s	Reference	Class 0.5	Reference	Class 0.2s	Reference
400 A	5 A	2.5 VA	192T 9340			2.5 VA	192T 9740		
500 A	5 A	2.5 VA	192T 9350			2.5 VA	192T 9750		
600 A	5 A	2.5 VA	192T 9360			2.5 VA	192T 9760		
750 A	5 A	2.5 VA	192T 9375			2.5 VA	192T 9775		
800 A	5 A	5 VA	192T 9380			5 VA	192T 9780		
1000 A	5 A	10 VA	192T 9390	5 VA	192U 9390	10 VA	192T 9790		
1200 A	5 A	10 VA	192T 9392	5 VA	192U 9392	10 VA	192T 9792	5 VA	192U 9792
1250 A	5 A	10 VA	192T 9393	5 VA	192U 9393	10 VA	192T 9793	5 VA	192U 9793
1500 A	5 A	15 VA	192T 9395	5 VA	192U 9395	15 VA	192T 9795	5 VA	192U 9795
1600 A	5 A	10 VA	192T 9394			15 VA	192T 9794		
2000 A	5 A	15 VA	192T 9396			15 VA	192T 9796	5 VA	192U 9796
2500 A	5 A					15 VA	192T 9797		
3000 A	5 A					25 VA	182T 9798 ⁽¹⁾		
4000 A	5 A					30 VA	182T 9799 ⁽¹⁾		

(1) Replacement model TRA 127 for this rating.

Accessories

Accessories	TBA 60 Reference	TBA 80 Reference	TBA 100 Reference	T2BA 100 Reference	TBA 103 Reference	T2BA 103 Reference	TBA 127 Reference	T2BA 127 Reference
Sealable cover	192T 0102		192T 0102	192T 0102			192T 0102	192T 0102

CT Plug-in transducer (CEA-VA)

Power supply	Output	TBA 100 Reference
Self-supplied	0-20 mA / 0-10 VDC	192Y 0045
230 VAC	0-20 mA / 0-10 VDC	192Y 0245
24 VDC	0-20 mA / 0-10 VDC	192Y 0145

CT Plug-in transducer (CEA-VA4)

Power supply	Output	TBA 100 Reference
230 VAC	4-20 mA / 0-10 VDC	192Y 0285
24 VDC	4-20 mA / 0-10 VDC	192Y 0185

Dimensions (mm)

TBA 60

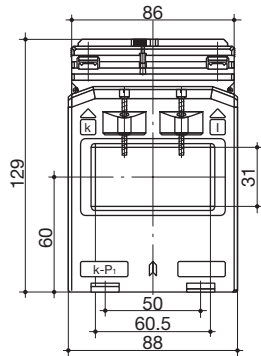

trafo_050_a_1_x_cat

TBA 80
300 to 2000 A

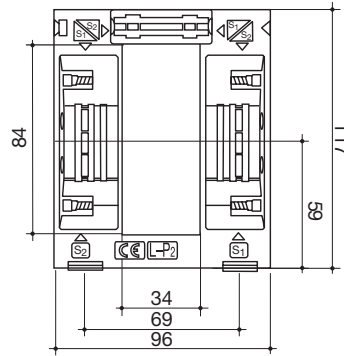

trafo_059_a_1_x_cat

TBA 100 600 to 2500 A⁽¹⁾
T2BA 100 1200 to 3000 A

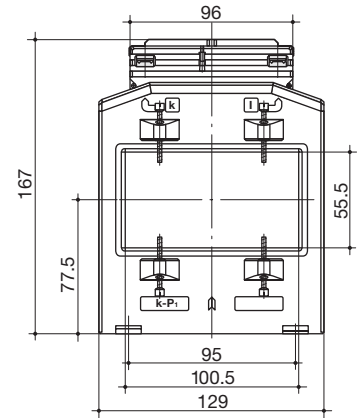

trafo_082_a_1_x_cat

(1) TBA 100, 3000 and 4000 A: 214 x 129 x 78 mm.

TBA 103 and T2BA 103

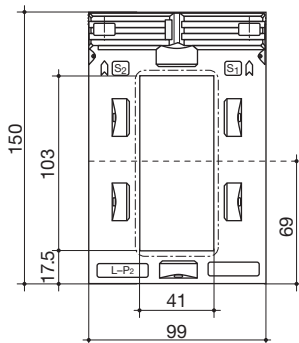

trafo_054_a_1_x_cat

TBA 127 and T2BA 127

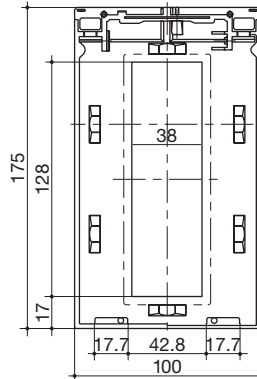

trafo_052_a_1_x_cat

Bar-through CT	TBA 60	TBA 80	TBA 100	T2BA 100	TBA 103	T2BA 103	TBA 127	T2BA 127
Bar (mm)	60 x 30	84 x 34	100 x 55	100 x 55	103 x 41	103 x 41	128 x 38	128 x 38
H x W x D (mm)	129 x 88 x 78	117 x 96 x 68	167 x 129 x 78 ⁽¹⁾	167 x 129 x 78	150 x 99 x 58	150 x 99 x 58	175 x 100 x 55	175 x 100 x 55

(1) TBA 100, 3000 and 4000 A: 214 x 129 x 78 mm.

Current transformers

Measurement devices

from 5 to 5000 A

Three-phase bar or cable-through CT

References

Primary	Secondary ⁽¹⁾	TCB3 18-20		TCB3 22-30	
		Class 1	Reference	Class 1	Reference
3 x 100 A	3 x 5 A	1 VA	192T 3310		
3 x 150 A	3 x 5 A	1.25 VA	192T 3315		
3 x 200 A	3 x 5 A	1.5 VA	192T 3320		
3 x 250 A	3 x 5 A	2.5 VA	192T 3325	2.5 VA	192T 3425
3 x 300 A	3 x 5 A			3.75 VA	192T 3430
3 x 400 A	3 x 5 A			5 VA	192T 3440
3 x 500 A	3 x 5 A			5 VA	192T 3450
3 x 600 A	3 x 5 A			5 VA	192T 3460

(1) Secondary 1 A: on request.

Dimensions (mm)

TCB3 18-20

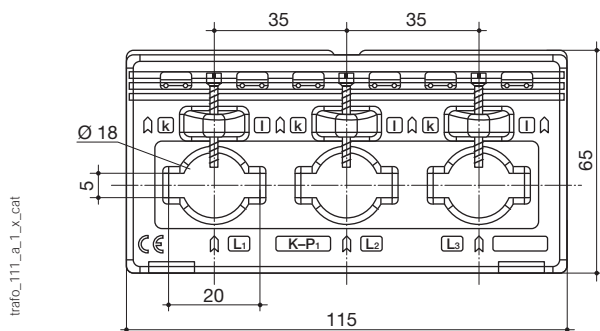

TCB3 22-30

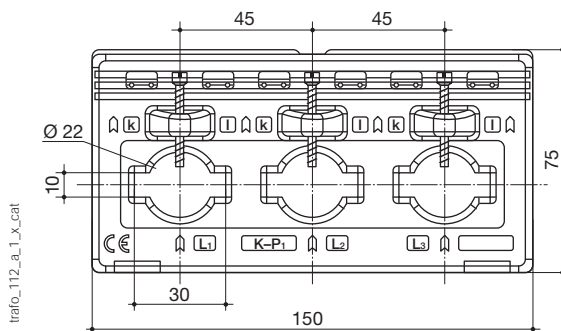

Three-phase bar or cable-through CT	TCB3 18-20	TCB3 22-30
Ø cable (mm)	18	22
Bar-through	20 x 5	30 x 10
H x W x D (mm)	115 x 65 x 37	150 x 75 x 37
DIN-rail mounting	no	no

References

Primary	Secondary ⁽¹⁾	TCA 13 — 3P	
		Class 1	Reference
3 x 50 A	5 A	1 VA	192T 1905
3 x 60 A	5 A	1.25 VA	192T 1906
3 x 75 A	5 A	1.5 VA	192T 1907
3 x 80 A	5 A	1.5 VA	192T 1908
3 x 100 A	5 A	2.5 VA	192T 1910
3 x 125 A	5 A	2.5 VA	192T 1912
3 x 150 A	5 A	2.5 VA	192T 1915
3 x 160 A	5 A	2.5 VA	192T 1916

(1) Secondary 1 A: on request.

Dimensions (mm)

TCA 13 — 3P

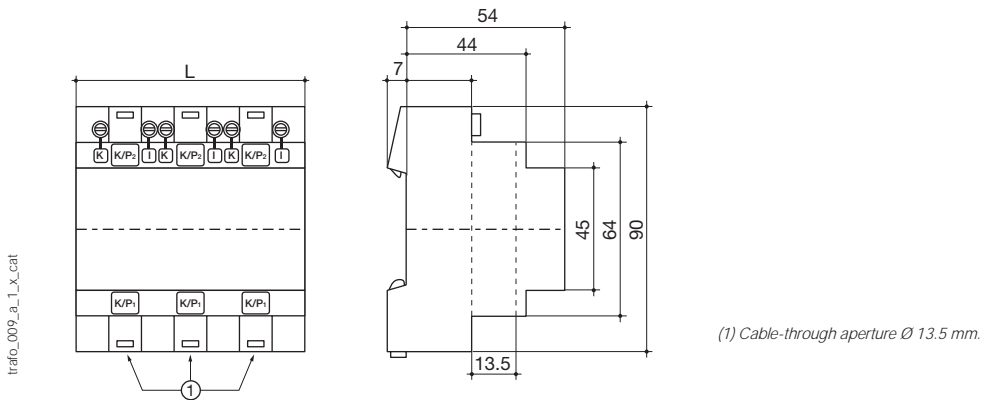

Number of modules	Front degree of protection	Terminal degree of protection	L (mm)	Mounting
6	IP65	IP20	105	35 mm DIN-rail

Current transformers

Measurement devices

from 5 to 5000 A

Split-core CT

References

Primary	Secondary	TO 23			TO 58			TO 812			TO 816	
		Class 1	Class 3	Reference	Class 0.5	Class 1	Reference	Class 0.5	Class 1	Reference	Class 0.5	Reference
100 A	5 A		1.25 VA	192T 4601								
150 A	5 A		1.5 VA	192T 4602								
200 A	5 A		2.5 VA	192T 4603								
250 A	5 A	1.5 VA		192T 4604		1.5 VA	192T 4625		1.5 VA	192T 4725		
300 A	5 A	3.75 VA		192T 4605		2.5 VA	192T 4630		2.5 VA	192T 4730		
400 A	5 A	5 VA		192T 4606	1 VA		192T 4640		2.5 VA	192T 4740		
500 A	5 A				2.5 VA		192T 4650	2.5 VA		192T 4750		
600 A	5 A				2.5 VA		192T 4660	2.5 VA		192T 4760		
750 A	5 A				2.5 VA		192T 4675	2.5 VA		192T 4775		
800 A	5 A				2.5 VA		192T 4680	2.5 VA		192T 4780		
1000 A	5 A				5 VA		192T 4610	5 VA		192T 4710	10 VA	192T 4810
1250 A	5 A							7.5 VA		192T 4712	10 VA	192T 4812
1500 A	5 A							7.5 VA		192T 4715	10 VA	192T 4815
1600 A	5 A										10 VA	192T 4814
2000 A	5 A										10 VA	192T 4820
2500 A	5 A										10 VA	192T 4825
3000 A	5 A										15 VA	192T 4830
4000 A	5 A										15 VA	192T 4840
5000 A	5 A										15 VA	192T 4850

Dimensions (mm)

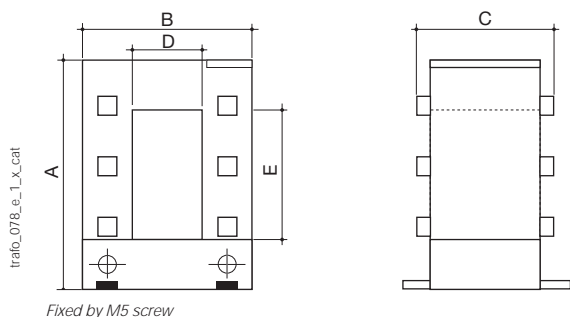

Dimensions (mm)

Type	A (mm)	B (mm)	C (mm)	D (mm)	E (mm)
TO 23	106	93	58	23	33
TO 58	158	125	58	55	85
TO 812	198	155	58	85	125
TO 816	243	195	79	85	165

Split-core CT	TO 23	TO 58	TO 812	TO 816
H x W x D (mm)	106 x 93 x 58	158 x 125 x 58	198 x 155 x 58	243 x 195 x 75

Summation CT

Reference

Primary	Secondary	BSA 02 Reference	BSA 03 Reference	BSA 04 Reference
5 + 5/5 A	5 A	192T 0802		
5A + 5+ 5/5	5 A		192T 0803	
5 + 5 + 5 + 5/5 A	5 A			192T 0904

Dimensions (mm)

BSA 02 and BSA 03

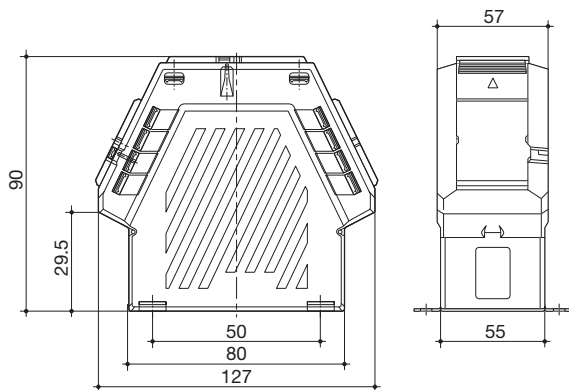

BSA 04

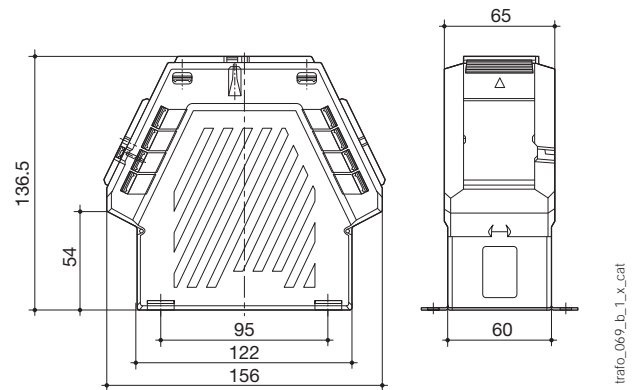

Summation CT	BSA 02	BSA 03	BSA 04
H x W x D (mm)	90 x 127 x 57	90 x 127 x 57	136.5 x 156 x 65
DIN-rail mounting	no	no	no



Selection guide

Software solutions for energy monitoring and analysis

What are the features?

For what size of project?

Where is the data stored?

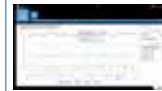
	WEBVIEW-S	WEBVIEW-M	WEBVIEW-L
			
Hosting of the application ⁽¹⁾	DIRIS A-40 Ethernet <i>p. 424</i>	DIRIS Digiware M-70 /D-70 <i>p. 424</i>	DATALOG H80/H81 <i>p. 424</i>
Data collection			
Maximum number of connected measurement devices	1	32	100 (WEBVIEW-L100) 200 (WEBVIEW-L200)
Interfacing to third-party applications			via connector
Export of data in CSV format	•	•	•
Real time monitoring			
U/V voltages and currents I	•	•	•
Powers P, Q, S, Power factor	•	•	•
Quality monitoring THDi, THDu, THDv, K factor, Harmonic analysis up to 63 rd	•	•	•
Energy metering Ea+, Ea-, Er+, Er-, Es	•	•	•
Pulse counting	•	•	•
Input/Output monitoring	•	•	•
Measurement history U, V, I, P, Q, S,	•	•	•
Energy analysis			
Energy consumption analysis	•	•	•
Multi-parameter analysis			•
Alarm management			
Product alarms	•	•	•
Alarms history	•	•	•
Transmission of alarms	e-mail	e-mail	e-mail
Reporting management			
Customisable user interface		Photoview	Photoview
Hierarchy management		•	•
Conformity to standards			
Energy Server Standard - IEC 62974-1		•	•

(1) For more information on the hardware please refer to the appropriate catalogue pages.

(2) N'VIEW is a software solution intended for energy management purposes only.

Architecture

Level 4
Cloud hosting

Level 3
Long-distance communication network (WAN)

Level 2
Local communication network (LAN)

Level 1
PMD & sensors

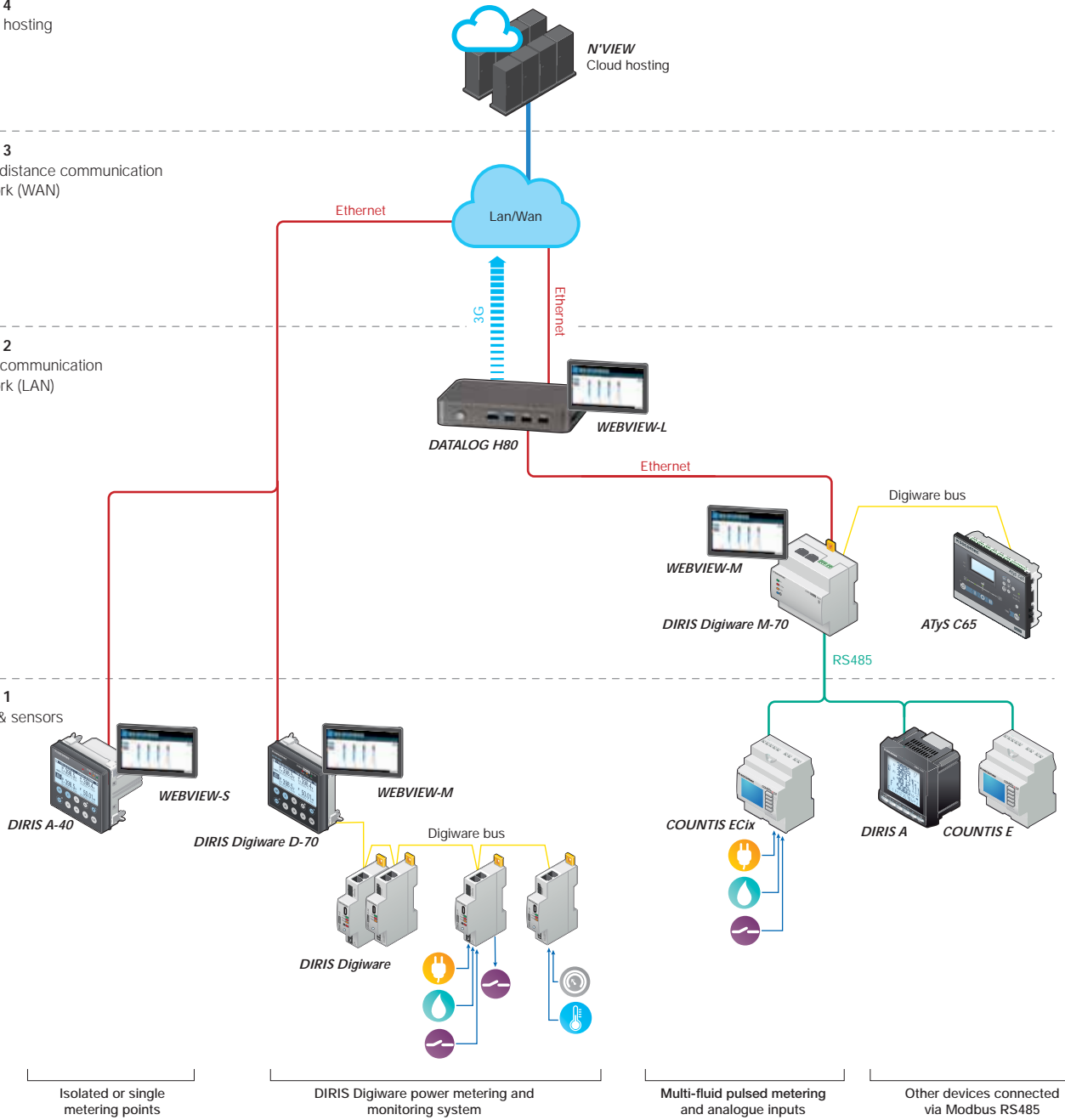

SOFT_1000_C_GB

Expert Services

Require integration onto your network?

No problem for our Expert Services team. They work out all the details of the measurement schedule, the complete integration of all devices in your energy management system, the configuration of your software application, the training of your teams and details of operational support. For further information, please contact your nearest Socomec office.

WEBVIEW

Embedded software for power monitoring and energy management



soft_076

The solution for

- > Industry
- > Building
- > Infrastructure
- > Local authority



Strong points

- > Plug & Play
- > Easy to use
- > Various functions

Compliance with standards

- > IEC 62974-1⁽¹⁾



(1) Energy Server standard applicable to WEBVIEW-M and L versions embedded in DIRIS Digiware M-70/D-70 and DATALOG H80.

Function

WEBVIEW is a web based software embedded in DIRIS A-40 power monitoring devices, DIRIS Digiware D-70 displays, DIRIS Digiware M-70 communication gateways and DATALOG H80/H81 dataloggers delivering real-time monitoring of all measurements from up to 200 devices and displaying the breakdown of energy consumptions.

Uncover the causes of electrical disturbances and anticipate maintenance requirements thanks to historical records of multiple electrical parameters.

Pre-set alarms defined by the user can be sent by e-mail. Users can access WEBVIEW via a web browser on a PC or a tablet.

Strong points

Plug & Play

Quickly configure WEBVIEW thanks to the automatic detection of Socomec devices. Create geographical and electrical hierarchies to reflect your installation and your processes.

Easy to use

WEBVIEW centralises measurements from all downstream devices via a single clear and user friendly interface. The ergonomics of each screen allow users to easily and quickly analyse the parameters and the behaviour of the installation.

Various functions

Very easy to configure and to use, WEBVIEW offers a wide range of features including real-time monitoring, alarm management and notification by e-mail, multi-utility analysis (electricity, water, gas), power parameter logging and allocation of consumption by end-use and location.

Characteristics

Type	Hosting	Functions	Number of measurement devices
WEBVIEW-S	DIRIS A-40	Monitor, Alarm, Analyse	1
WEBVIEW-M	DIRIS Digiware M-70	Monitor, Alarm, Analyse, Photoview	32
	DIRIS Digiware D-70	Monitor, Alarm, Analyse, Photoview	32
WEBVIEW-L	DATALOG H80/H81	Monitor, Alarm, Analyse, Photoview	100/200

Functions

Monitor

- Automatic detection of connected devices.
- Summary of the parameters measured for the electrical network and loads.
- Display of voltage, current, power, power factor, total harmonic distortion (THD) and harmonics per rank.
- Display of average/instantaneous values with min/max limits depending on the devices.
- Total and partial energy consumption per load.
- Input/output status.
- Synchronisation of device clocks.
- Graphical or table representation.

Alarm

- Alarms for overloads, events and input status changes.
- Display of alarms history.
- Sorting by type, nature, criticality or state.
- Alarms displayed on the main page.
- Alarm notification by e-mail (SMTP).

Analyse

- Historical measurements and consumption.
- Historical records of multiple electrical parameters.
- Breakdown of consumption by location, by end-use and by utility type (water, gas, electricity...).
- Export of consumption data in a CSV format.

Photoview

- Photoview: customised dashboard of the WEBVIEW environment via the upload of graphical files (building plans, electrical circuit diagrams, production processes...)
- Real time monitoring via drag and drop of parameters on the background pictures (measurement points, alarms, text...).
- Display of the mapping of the measurement plan by cascading of several images.



sofL_07.6.eps



sofL_07.4.eps



sofL_07.5.eps



sofL_06.4.eps

References



Type	Host device	Reference
WEBVIEW-S	DIRIS A-40	4825 0501
WEBVIEW-M	DIRIS Digiware M-70	4829 0222
	DIRIS Digiware D-70	4829 0203
WEBVIEW-L 100	DATALOG H80	4854 0020
	DATALOG H81 (3G network)	4854 0021
WEBVIEW-L 200	DATALOG H80	4854 0030
	DATALOG H81 (3G network)	4854 0031

Easy Config System

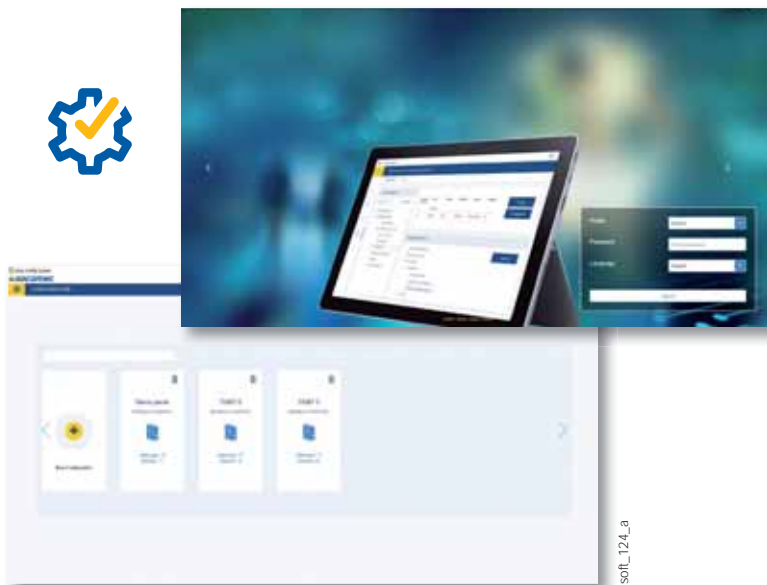
Configuration software



Strong points

-  > Faster
-  > More reliable
-  > More flexible

Compatible with



- > DIRIS Digiware power monitoring system



- > DIRIS A & B power monitoring devices



- > ISOM insulation monitoring systems



- > COUNTIS E energy meters



- > ATyS C55/C65, ATyS p and ATyS pm transfer switches and controllers

Free download Easy Config System



https://www.socomec.com/easy-config-system_en.html

Function

With the **Easy Config System**, you can configure your Socomec power monitoring and load-breaking equipment while visualising all electrical measurements in real time.

Its speed and simplicity make the Easy Config System software an essential tool for:

- Panel builders and system integrators who want to provide correctly configured electrical panels for their customers
- Operators who want to configure their devices on their own or change specific settings

The bonus: you can easily save and modify your configurations and also duplicate them from one device to another or from one system to another.

Advantages

Quick configuration

Easy Config System is a quick and easy way for system integrators and panel builders to configure their installations:

- Automatic discovery of connected devices
- Configuration of multiple devices at the same time
- Duplication of configurations between devices.

Local or remote access

You can access Easy Config System either locally by connecting it to devices via a USB cable, or remotely with an Ethernet connection. This system provides great flexibility taking into account the constraints of your facility. With the remote access option, you can change settings and correct any configuration or wiring errors, without having to physically return to site.

Reliable data

Easy Config System has a dynamic dashboard (see next page) which adapts to the type of device and can display the phasor diagram, the alarms in progress or detected sensors and their ratings. It also provides an overview of the topology, listing the connected devices, with their firmware versions and internal clock, and the quality of communication.

This ensures the user that the wiring and configuration are correct and, as a result, data is reliable.

Configuration options

Configure the entire system with an Ethernet connection to a DIRIS Digiware M-xx gateway

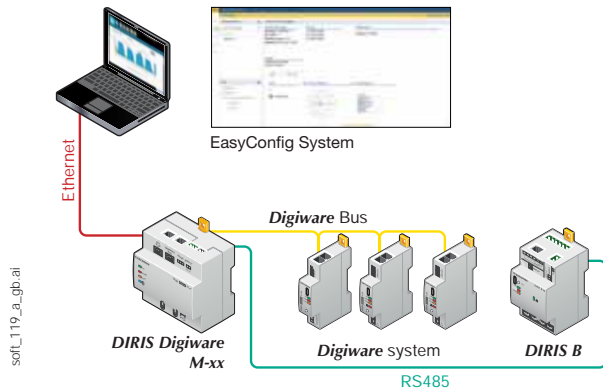

Configure the entire system with an Ethernet connection to a DIRIS Digiware D-xx display

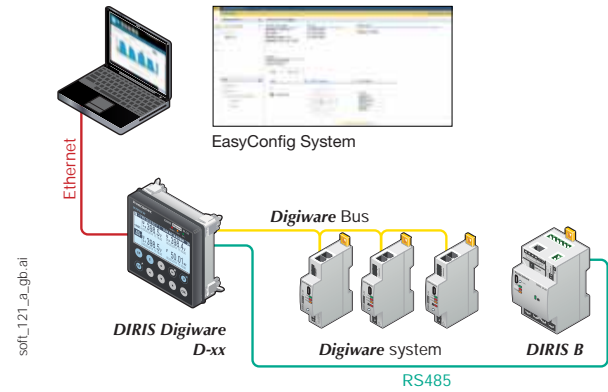

Configure the equipment via USB only

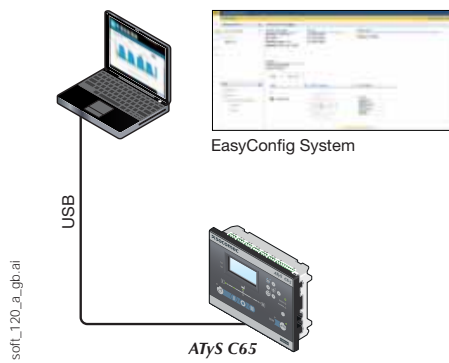

Configure the entire system with a USB connection to a DIRIS Digiware M-xx gateway

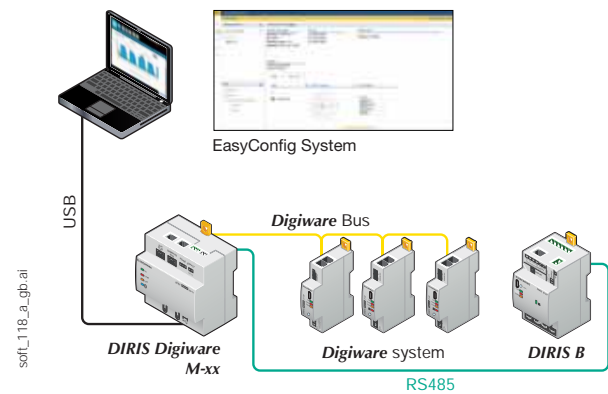

A dashboard adapted to each type of device

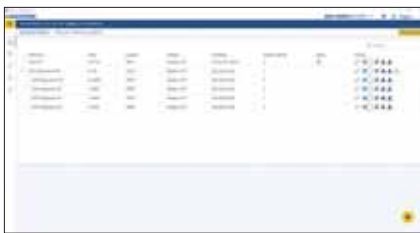

D-xx displays and M-xx gateways

- List of products in the topology
- Firmware versions of connected devices
- Internal clock for connected devices
- Enabled services
- Communication diagnostics

Multifunction meters

- U/I phasor diagram
- Main electrical readings
- AutoCorrect wiring diagnostics
- Connected sensors and their ratings
- Alarms in progress

Transfer switches

- Electrical data on each source
- Status of primary and secondary sources
- Input/output state
- Alarms in progress
- Operating modes (AUTO/MANU/TEST)
- Timers



Electronic protection

Effective protection for your electrical installation	<i>p. 430</i>
Differential protection selection guide	<i>p. 432</i>

Differential protection



RESYS M40
p. 434



RESYS M40R
p. 436



RESYS P40
p. 438

Expert Services

Our experts are here for you to make your project a success.
see *p. 8*.

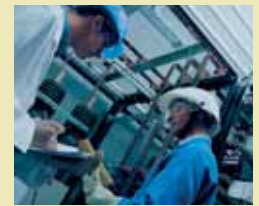

Effective protection for your electrical installation

All electrical installations, particularly those which incorporate sensitive loads, must be appropriately monitored and/or protected against indirect contact, earth leakage currents, short circuits and voltage surges.

To secure your installation against these various risks, we offer a range of protection devices which have been grouped under the heading "Electronic protection":

- **RESYS earth leakage relays**

See our selection guide, "Differential protection".

With many years of experience in the industry and an extensive knowledge of installation standards, SOCOMEC delivers much more than high-performance products. Our services include:

- auditing your low-voltage installation
- defining protection requirements
- seamless product integration into your electrical distribution system
- system commissioning
- training on the use of, and the standards applicable to, the system
- turnkey monitoring solutions.

Contact us now and let us provide you with a solution for your installation.

Important!

Sound knowledge of your electrical network is essential in ensuring the successful outcome of your project.

Your choice of electronic protection devices and their location on your installation depends on:

- the type of supply source,
- the length of the conductors,
- the type and nature of the electrical loads connected to the network.

Expert Services

We will help you design your protection solution, guaranteeing perfect integration of the products in your installation.

For further information, please contact your nearest SOCOMEC branch.

Differential protection: a RESYS solution for each application



APPL1268 A

Motor feeder application.



SITE 538 A

Industrial site application.



APPL1146 A

Local battery application.

Earth leakage relays fulfil two key functions:

- **Protection against indirect contact** in the following earthing schemes:
 - TT (mandatory)
 - TNS and IT on second fault (with long conductor lengths)
 - IT (with multiple earthing points in an LV network).
- **Prevention/signalling** for TNS or TT earthing arrangements.

In both cases, you need to identify the type of load present on your network to choose the most suitable differential relay.

There are three types of relay:

- **Type AC** for loads that may cause a pure sinusoidal AC earth leakage current
- **Type A** for loads that may generate an AC and/or a pulsing DC earth leakage current
- **Type B** for loads that may generate a DC earth leakage current (including protection types AC & A)

You can combine SOCOMEC toroids and earth leakage relays to suit the needs of each application:

- Interference from variable speed drives, dimmers, etc. through their TRMS measurement: RESYS relay type A or B
- Presence of pulsing components: RESYS relay type A
- Presence of DC circuits: RESYS relay type B.

Due to the mixture of components and loads in industrial applications type AC differential relays do not cover all the necessary requirements, therefore SOCOMEC proposes type A and B differential relays.

What you need to know

To identify the different categories of load present in your installation, visit our website www.socomec.com/en/resys



Selection Guide

Differential protection

Which requirement?



Which application?

Applications	Motor load break	
		
Model	RESYS M40 <i>p. 434</i>	RESYS P40 <i>p. 436</i>
Characteristics		
Type of protection DDR	A type	A type
Tripping threshold	30 mA ... 30 A	30 mA ... 30 A
Time setting	0 ... 10 s	0 ... 10 s
Automatic reclosing function		
Pre-alarm function	•	•
Output contact	2	2
Case	DIN modular	Panel mounting
Dimensions (mm)	44	48x48
Accessories		
Core balance transformers		
Circular closed toroids ΔIC	•	•
Split-core balance transformer ΔIP-R	•	•
Rectangular closed toroids WR	•	•

Which type of protection?

	Isolated sites
	
	RESYS M40R <i>p. 438</i>
	A type
	30 mA ... 30 A
	0 ... 10s
	•
	2
	Modular
	44
	•
	•
	•

RESYS M40

Type A differential relays
for motor load break



resys_083_a_1_cat

The solution for

- > Processes
- > Manufacturing
- > Oil, gas and petrochemistry
- > Energy production

Strong points

- > Fully configurable
- > Measurement accuracy by TRMS
- > Instantaneous display of permanent leakage currents
- > Compact and modular case with LED bargraph
- > Improved immunity to EMC interferences

Conformity to standards

- > IEC 60755
- > IEC 60947-2
- > IEC 60664
- > IEC 61543 A1



Approvals and certifications⁽¹⁾



(1) Product reference on request.

Function

RESYS M40 earth leakage relays associated with a remote trip breaking device (automatic power breaking), provide the following functions:

- protection against indirect contact,
- limitation of leakage currents.

They also preventively monitor electrical installations via their (configurable) pre-alarm function or when used as signalling relays.

Advantages

Fully configurable

- 2 relays with configurable function (alarm or pre-alarm at 50% $I_{\Delta n}$).
- Adjustment of $I_{\Delta n}$ from 0.03 to 30 A.
- Time delay 0 to 10 s.
- Positive or negative security configurable by the user.
- Selection of toroid ratio.

Instantaneous display of permanent leakage currents.

The LED bargraph provides a real-time display of fluctuations in leakage currents.

Compact modular design

44 mm in width, the unit allows easy integration into dedicated enclosures. The adjustment buttons are protected by a sealable cover, while the display of available alarms is displayed directly on the front face of the device.

Tripping accuracy by TRMS measurement

Improves immunity to nuisance tripping.

Improved immunity to EMC interferences

The device has new electronics which improve electromagnetic compatibility.

Applications

Rapid recognition of an insulation fault increases the availability of the distribution network by preventing accidental power cuts and the resulting loss of production.

Protection against fire or explosion risks

The use of Residual Differential Devices (with adjustment $I_{\Delta n} \leq 300$ mA) provides protection against the risk of fire or explosion generated by tracking currents to earth, in areas classed as BE2 or BE3 respectively. This protection is mandatory in TT, TN and IT neutral systems.

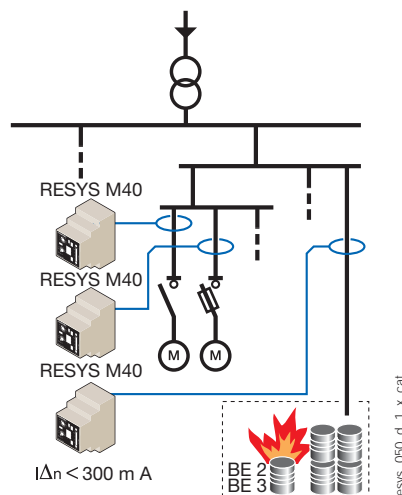

Front panel

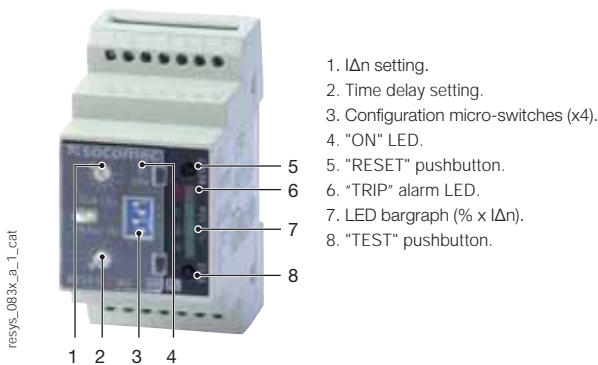

General characteristics

- RESYS M40 with 2 configurable relays:
 - either 2 alarm relays,
 - or 1 alarm relay and 1 pre-alarm relay (50% $I_{\Delta n}$).
- Adjustment sensitivity from 0.03 mA to 30 A.
- Time delay 0 to 10 s.
- Tripping accuracy by TRMS measurement.
- Automatic instantaneous tripping at 30 mA.
- Positive or negative security configurable by the user.
- Selection of toroid ratio.
- Automatic permanent relay-toroid connection test.
- Sealable cover.

Characteristics

Auxiliary power supply U_s	
Frequency	47 ... 63 Hz
AC operating zone	0.8 ... 1.15 U_s
DC operating zone	0.8 ... 1.05 U_s
Max. consumption	6 VA (AC) / 5 W (DC)
Insulation (according to IEC 60664-1 standard)	
Rated insulation voltage	250 VAC
Rated impulse voltage	2.5 kV (115 VAC) / 4 kV (230/400 VAC)
Degree of pollution	Class 3
Threshold values	
$I_{\Delta n}$ setting	0.03 - 0.1 - 0.3 - 0.5 - 1 - 3 - 5 - 10 - 30 A
Accuracy of tripping	- 20 ... - 10 % $I_{\Delta n}$
Domain of mains frequency	15 ... 400 Hz
Time delay setting	0 - 0.06 - 0.15 - 0.30 - 0.50 - 0.80 - 1 - 4 - 10 s
PRE-ALARM relay tripping	50 % $I_{\Delta n}$
Hysteresis of the PRE-ALARM relay	20 % $I_{\Delta n}$

Alarm	
Alarm configuration mode	storage / automatic reset
Alarm factory setting	storage
Reset	manual by pushbutton / using terminal

Output contacts	
Number of contacts	2
Type of ALARM 1 contact	250 VAC - 8 A - 2000 VA
Type of ALARM 2 or PRE-ALARM contact	250 VAC - 6 A - 1500 VA
ALARM 1 operating mode	positive / negative security ⁽¹⁾
ALARM 2 or PRE-ALARM operating mode	positive security ⁽¹⁾
Factory setting of ALARM 1 operating mode	negative security
Factory setting of ALARM 2 operating mode	positive security

(1) Negative security: relay activated in case of alarm / Positive security: relay not activated in case of alarm.

Operating conditions	
Operating temperature	- 20 ... + 55 °C
Storage temperature	- 30 ... + 70 °C

Case

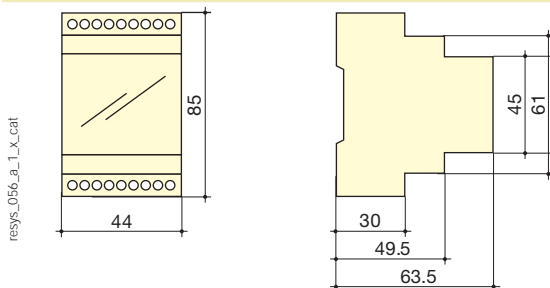

Type	modular
Number of modules	2.5
Dimensions W x H x D	44 x 85 x 63.5
Case protection index	IP40
Terminal protection index	IP20
Rigid cable cross-section	0.2 ... 4 mm ²
Flexible cable cross-section	0.2 ... 2.5 mm ²
Weight	190 g

Terminals and connections

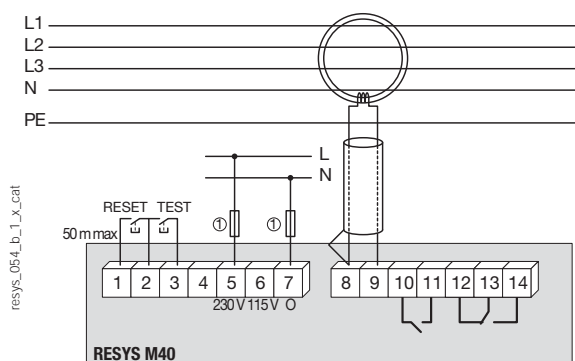

- 1 - 2 - 3: external push buttons
- 5 - 6 - 7: auxiliary power supplies U_s
- 8 - 9: SOCOMEC differential toroid connections
- 10 - 11: alarm relay 2 or pre-alarm outputs
- 12 - 13 - 14: alarm relay 1 output

Note: The earth conductor must not pass through the toroid.

For single phase applications, only the live and neutral need to be passed through the toroid.

Cabling: for distances > 1 m, use twisted pair cable between the unit and toroid. Do not connect the shield to earth.

1. Fuses 2 A gG.

References

Auxiliary power supply U_s⁽¹⁾	RESYS M40 Reference
115 / 230 VAC	4941 3723 ⁽²⁾
400 VAC	4941 3740 ⁽²⁾
12 ... 125 VDC	4941 3602 ⁽²⁾

(1) Other rating: Please consult us. (2) References and characteristics of closed, split core and rectangular toroids: see "Core balance transformers type A"

RESYS M40R

Type A earth leakage relays
with automatic reclosing



Function

RESYS M40R earth leakage relays associated with a remote trip breaking device (automatic power breaking and reclosing), provide the following functions:

- protection against indirect contact,
- limitation of leakage currents.
- reclosing of trip breaking device after earth leakage detection and power supply breaking.

The relay recloses the system up to six consecutive times after different time intervals. If the fault is still present after the sequence of six reclosing attempts, the relay is locked in alarm mode and a manual intervention will be required.

Rapid recognition of an insulation fault increases the availability of the distribution network by preventing accidental power cuts and the resulting loss of production. TRMS measurement avoids repeated random tripping and the bargraph allows the display of permanent leakage current.

Advantages

Automatic reclosing

This function provides protection, particularly in isolated sites or for processes requiring a restart in the event of transient faults (continuity of service ensured in the absence of a maintenance team).

Fully configurable

- Adjustment of $I_{\Delta n}$ from 0.03 to 30 A.
- Time delay 0 to 10 s.

Ensures continuity of the power supply for strategic applications or in isolated sites

In the majority of cases, where the fault is not permanent, simply reclosing may resolve the situation.

Tripping accuracy by TRMS measurement

Improves immunity to nuisance tripping.

Instantaneous display of permanent leakage currents

The LED bargraph provides a real-time display of fluctuations in leakage currents.

The solution for

- > Power distribution (Public lighting)
- > Water treatment
- > Processes
- > Telecom, Datacom and broadcasting
- > Farm buildings

Strong points

- > Automatic reclosing
- > Fully configurable
- > Continuity of the power supply for strategic applications
- > Tripping accuracy by TRMS measurement
- > Instantaneous display of permanent leakage currents

Conformity to standards

- > IEC 60755
- > IEC 60947-2
- > IEC 60664
- > IEC 61543 A1



Applications

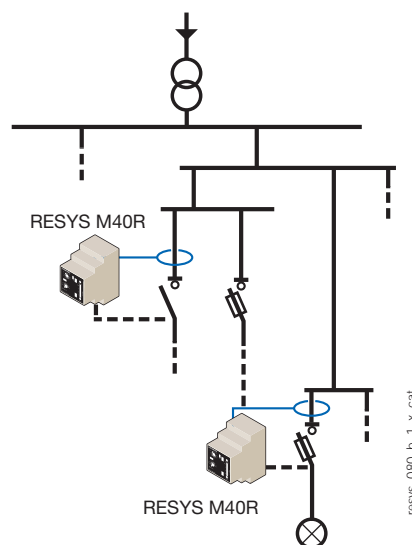

The RESYS M40R relay must be combined with an automatic tripping/reclosing breaking device:

- a motorised switch
- a device fitted with an undervoltage coil
- a contactor.

Front panel

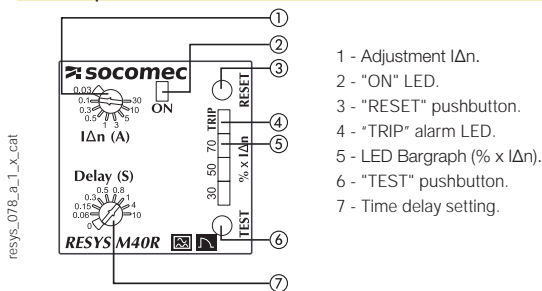

- 1 - Adjustment $I_{\Delta n}$.
- 2 - "ON" LED.
- 3 - "RESET" pushbutton.
- 4 - "TRIP" alarm LED.
- 5 - LED Bargraph (% $\times I_{\Delta n}$).
- 6 - "TEST" pushbutton.
- 7 - Time delay setting.

Case

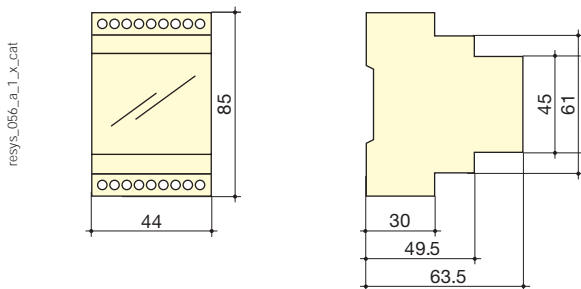

Type	modular
Number of modules	2.5
Dimensions W x H x D	44 x 85 x 63.5 mm
Case protection index	IP40
Terminal protection index	IP20
Rigid cable cross-section	0.2 ... 4 mm ²
Flexible cable cross-section	0.2 ... 2.5 mm ²
Weight	190 g

Characteristics

Auxiliary power supply U_s

Frequency	47 ... 63 Hz
AC operating zone	0.8 ... 1.15 U_s
DC operating zone	0.8 ... 1.05 U_s
Max. consumption	6 VA (AC) / 5 W (DC)

Insulation (according to IEC 60664-1 standard)

Rated insulation voltage	250 VAC
Rated impulse voltage	2.5 kV (115 VAC) / 4 kV (230/400 VAC)
Degree of pollution	Class 3

Threshold values

$I_{\Delta n}$ setting	0.03 - 0.1 - 0.3 - 0.5 - 1 - 3 - 5 - 10 - 30 A
Accuracy of tripping	- 20 ... - 10 % $I_{\Delta n}$
Domain of mains frequency	15 ... 400 Hz
Time delay setting	0 - 0.06 - 0.15 - 0.30 - 0.50 - 0.80 - 1 - 4 - 10 s

Reclosing

Nb of automatic reclosing attempts	6 max
Time delay between two reclosing	7.5 - 15 - 30 - 60 - 120 - 240 s
Reset of automatic reclosing counter (t_{CR})	15 min

Alarm

Alarm configuration mode	automatic reset (6x max, then recording)
Reset	manual by pushbutton / using terminal

Output contacts

Number of contacts	2
Type of ALARM 1 contact	inverter
Type of ALARM 2 contact	simple
Characteristics contact ALARM 1	250 VAC - 8 A - 2000 VA
Characteristics contact ALARM 2	250 VAC - 6 A - 1500 VA
ALARM 1 operating mode	negative security ⁽¹⁾
ALARM 2 operating mode	positive security ⁽¹⁾

(1) Negative security: relay activated in case of alarm /

Positive security: relay not activated in case of alarm.

Operating conditions

Operating temperature	- 20 ... + 55 °C
Storage temperature	- 30 ... + 70 °C

Terminals and connections

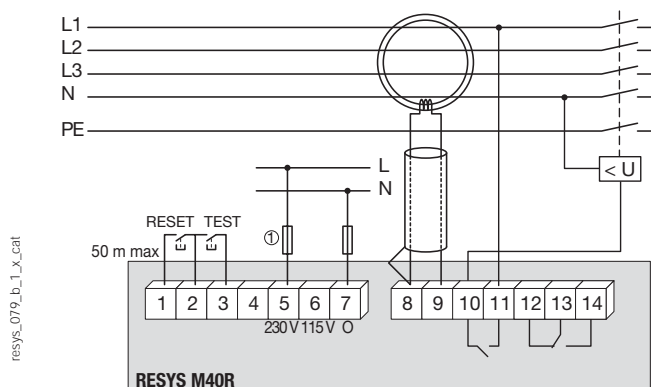

1. Fuses 2 A gG.

1 - 2 - 3: external push buttons

5 - 6 - 7: auxiliary power supplies U_s

8 - 9: SOCOMEC differential toroid connections

10 - 11: alarm relay 2 output

12 - 13 - 14: alarm relay 1 output

Note: The earth conductor must not pass through the toroid.

For single phase applications, only the live and neutral need to be passed through the toroid.

Cabling: for distances > 1 m, use twisted pair cable between the unit and toroid. Do not connect the shield to earth.

References

Auxiliary power supply U_s⁽¹⁾	RESYS M40R
115/230 VAC	Reference
400 VAC	4941 3724
	4941 3741

(1) Other rating: Please consult us.

RESYS P40

Type A earth leakage relays
for motor load break



RESYS P40

Function

RESYS P40 earth leakage relays associated with a remote trip breaking device (automatic power breaking), provide the following functions:

- protection against indirect contact,
- limitation of leakage currents.

They also preventively monitor electrical installations via their (configurable) pre-alarm function or when used as signalling relays.

Advantages

Fully configurable

- 2 relays with configurable function (alarm or pre-alarm at 50% $I_{\Delta n}$).
- Adjustment of $I_{\Delta n}$ from 0.03 to 30 A.
- Time delay 0 to 10 s.
- Positive or negative security configurable by the user.
- Selection of toroid ratio.

Tripping accuracy by TRMS measurement

Improves immunity to nuisance tripping.

Instantaneous display of permanent leakage currents.

The LED bargraph provides a real-time display of fluctuations in leakage currents.

Compact sealed case

Compact 48 x 48 mm case is particularly well suited to integration in MCCs with high density withdrawable compartments.

Improved immunity to EMC interferences

The device has new electronics which improve electromagnetic compatibility.

The solution for

- > Process
- > Manufacturing
- > Oil, gas and petrochemistry

Strong points

- > Fully configurable
- > Tripping accuracy by TRMS measurement
- > Instantaneous display of permanent leakage currents
- > Compact sealed case
- > Improved immunity to EMC interferences

Conformity to standards

- > IEC 60755
- > IEC 60947-2
- > IEC 60664
- > IEC 61543 A1



Approvals and certifications⁽¹⁾



(1) Product reference on request.

Applications

Rapid recognition of an insulation fault increases the availability of the distribution network by preventing accidental power cuts and the resulting loss of production. RESYS P40 are particularly suitable for insertion in electricity control panels with withdrawable compartments.

Protection against fire or explosion risks

The use of Residual Differential Devices (with adjustment $I_{\Delta n} \leq 300$ mA) provides protection against the risk of fire or explosion generated by tracking currents to earth, in areas classed as BE2 or BE3 respectively. This protection is mandatory in TT, TN and IT neutral systems.

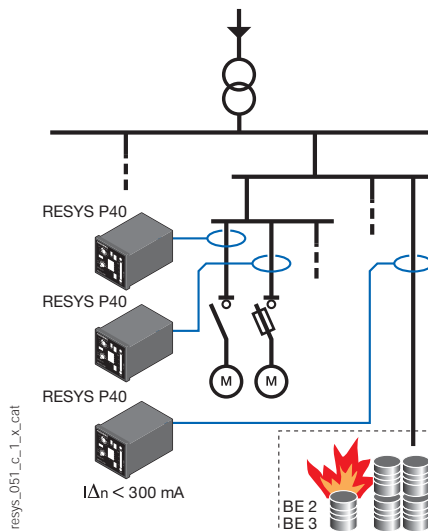

Front panel

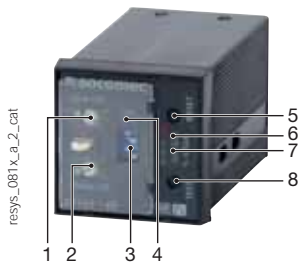

1. $I_{\Delta n}$ setting.
2. Time delay setting.
3. Configuration micro-switches (x4).
4. "ON" LED.
5. "RESET" pushbutton.
6. "TRIP" alarm LED.
7. LED bargraph (% $\times I_{\Delta n}$).
8. "TEST" pushbutton.

Characteristics

Auxiliary power supply U_s	
Frequency	47 ... 63 Hz
AC operating zone	0.8 ... 1.15 U_s
DC operating zone	0.8 ... 1.05 U_s
Consumption	6 VA (AC) / 5 W (DC)
Insulation (according to IEC 60664-1 standard)	
Rated insulation voltage	250 VAC
Rated impulse voltage	2.5 kV (115 VAC) / 4 kV (230/400 VAC)
Degree of pollution	Class 3
Threshold values	
$I_{\Delta n}$ setting	0.03 - 0.1 - 0.3 - 0.5 - 1 - 3 - 5 - 10 - 30 A
Accuracy of tripping	- 20 ... - 10 % $I_{\Delta n}$
Domain of mains frequency	15 ... 400 Hz
Time delay setting	0 - 0.06 - 0.15 - 0.30 - 0.50 - 0.80 - 1 4 - 10 s
PRE-ALARM relay tripping	50 % $I_{\Delta n}$
Hysteresis of the PRE-ALARM relay	20 % $I_{\Delta n}$

Alarm	
Alarm configuration mode	storage / automatic reset
Alarm factory setting	storage
Reset	manual by pushbutton / using terminal
Output contacts	
Number of contacts	2
Type of ALARM 1 contact	250 VAC - 8 A - 2000 VA
Type of ALARM 2 or PRE-ALARM contact	250 VAC - 6 A - 1500 VA
ALARM 1 operating mode	positive / negative security ⁽¹⁾
ALARM 2 or PRE-ALARM operating mode	positive security ⁽¹⁾
Factory setting of ALARM 1 operating mode	negative security
Factory setting of ALARM 2 operating mode	positive security
<small>(1) Negative security: relay activated in case of alarm / Positive security: relay not activated in case of alarm.</small>	
Operating conditions	
Operating temperature	- 20 ... + 55 °C
Storage temperature	- 30 ... + 70 °C

Case

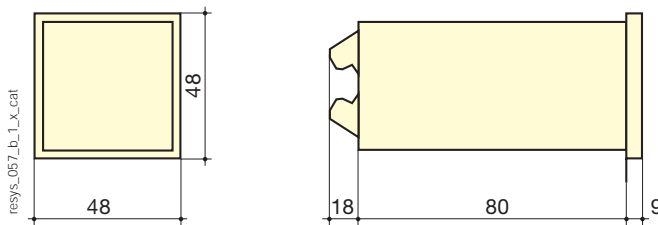

Type	panel mounting
Dimensions W x H x D	48 x 48 x 107 mm
Case protection index	IP40
Terminal protection index	IP20
Rigid cable cross-section	0.2 ... 4 mm ²
Flexible cable cross-section	0.2 ... 2.5 mm ²
Weight	190 g
Cutout	45 x 45 mm

Terminals and connections

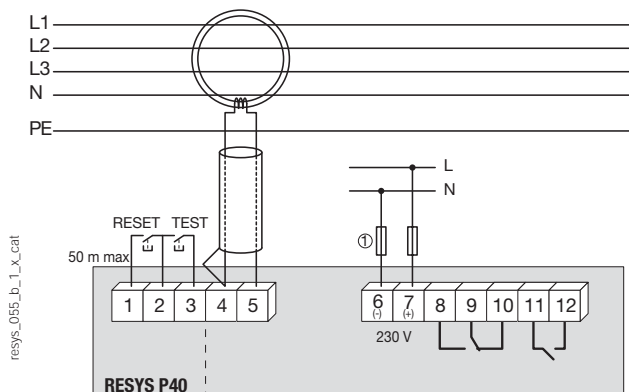

- 1 - 2 - 3 : external push buttons
- 4 - 5 : SOCOMEC differential toroid connections
- 6 - 7 : Auxiliary power supply U_s
- 8 - 9 - 10 : alarm relay 1 output
- 11 - 12 : alarm relay 2 or pre-alarm outputs

Note: The earth conductor must not pass through the toroid.
For single phase applications, only the live and neutral need to be passed through the toroid.

Cabling: for distances 1 m, use twisted pair cable between the unit and toroid.
Do not connect the shield to earth.

1. Fuses 2 A gG .

References

Auxiliary power supply U_s⁽¹⁾	RESYS P40 Reference
115 VAC	4942 3711 ⁽²⁾
230 VAC	4942 3723 ⁽²⁾
12 ... 125 VDC	4942 3602 ⁽²⁾
<small>(1) Other rating: Please consult us. (2) References and characteristics of closed, split core and rectangular toroids: see "Core balance transformers type A"</small>	
Description of accessories	Reference
Soft protection cover IP65	4942 0000

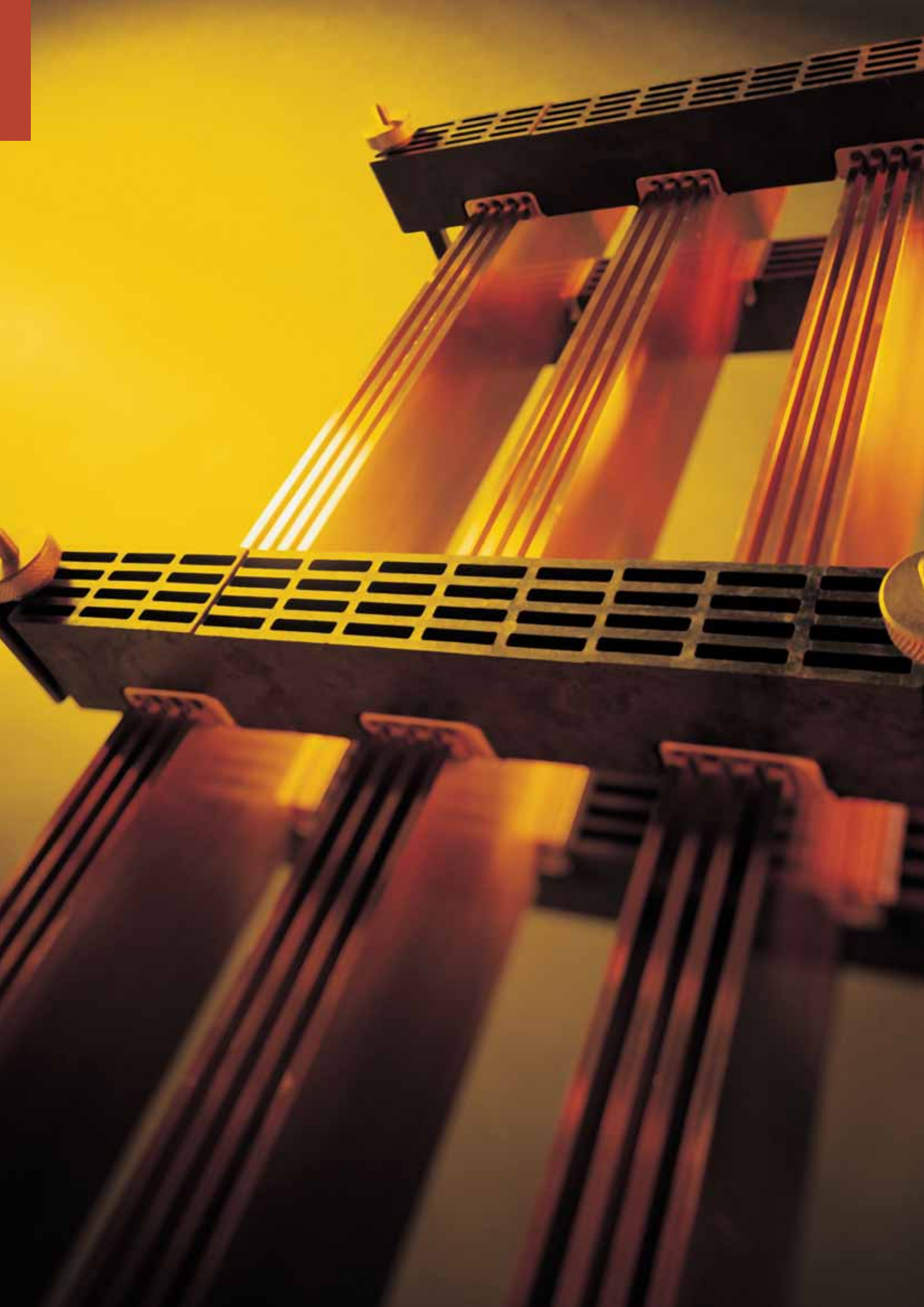

Mounting and cabling accessories for electrical cabinets

Distribution of electric energy

Busbars *p. 442*



Edgewise mounting with fixed interphase
p. 444



Edgewise mounting with adjustable interphase
p. 454



Flat mounting with fixed interphase
p. 458



Unipolar flat-mounted
p. 464



Other supports
p. 472

Power distribution

High power



Distribution blocks
p. 474

Medium power



Distribution blocks
p. 474

Busbar supports

Busbars



sb_214.psd

Fixed interphase, SB C 15



sb_103.eps

Insulators

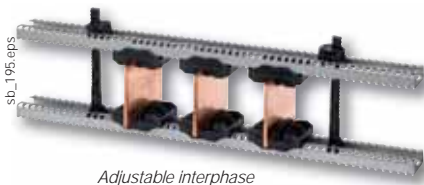

sb_195.eps

Adjustable interphase



sb_084.eps

Stair type support

The solution for

- > Electrical distribution



Conformity with standards

- > IEC 61439-1
- > IEC 60865-1



Approvals and certifications ⁽¹⁾

- > ASEFA/LCIE



⁽¹⁾ Product part numbers on request.

Function

SOCOMEK **insulating busbar supports** enable the fixing and holding in place of copper or aluminium busbars or busbar systems during a short-circuit.

Characteristics

Insulators

- Polyester without halogen.
- UL94 VO self-extinguishing.
- Colour red RAL 3002.
- Operating temperature from -40 °C to +130 °C.
- Deformation under load temperature (ASTM D643): > 200 °C.
- Dielectric constant (ASTM D150): 4/5.
- Arc resistance (ASTM D495): > 180 s.
- Water absorption (ASTM D570): < 0.3%.

Busbar supports

- High dielectric strength.
- High mechanical resistance.
- Amagnetism of assembly parts.
- High resistance to damp heat (supplied "tropicalised").

Stair type supports

- Thermoplastic material.
- VO self-extinguishing.
- Insulating voltage: 1000 V.

Software tool for size selection



sb_201_b_1_fr_cateps

Strong points

- > Easy to install and use
- > Manages changes depending on environmental conditions

Function

Mechanical System is a multi-language software used for sizing busbar systems. It defines the configuration of the busbar system, including bar section and distance between supports, according to the required electrical characteristics of the panel in compliance with standard IEC 61439-1.

Advantages

Easy to install and use

The Mechanical System software is available for download from www.socomec.com. Once installed, the software can be used offline. It runs on Windows.

Manages changes depending on environmental conditions

Mechanical System allows you to perfectly adapt the copper section according to the environmental conditions of your panel and installation.

Busbar supports

Edgewise mounting with fixed interphase

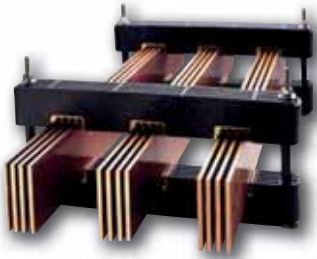

SBC 20



SB C 10

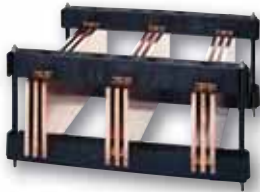

SB C 30

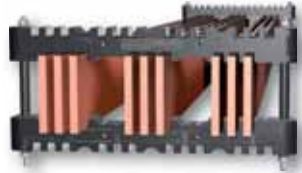

SB C 15

The solution for

- > Electrical distribution



Conformity with standards

- > IEC 61439-1
- > IEC 60865-1



Strong points

- > Insulating materials
- > Durability
- > Easy to use
- > Extensive range

Function

With SOCOMEC's insulating **bar supports** you can:

- mount and attach the busbars inside the electrical panel,
- cope with the forces experienced by the busbars during a short circuit.

Advantages

Insulating materials

- Our range of SB C edgewise mounting bar supports is made using thermoplastic. This very resistant material (reinforced fibreglass) is insulating so there are no risks in terms of clearance and creepage distances.

Durability

- Most bar supports have an M8 screw connection which provides outstanding robustness to the entire busbar structure.

Easy to use

- Only one type of spacer kit is required for the whole range of edgewise mounting busbar supports (SB C) with fixed interphase.

Extensive range

- Our range of bar supports allows you to assemble busbars with up to 120 kA of short-circuit current.

Selection guide

Edgewise mounting

- Busbar supports with fixed interphase

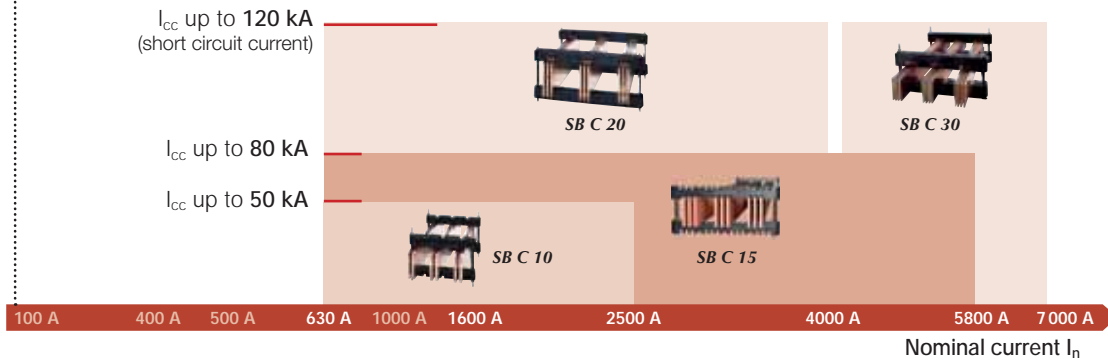

What you need to know

Bars joined by reversing a support
Compatible with SB C 10 and SB C 20

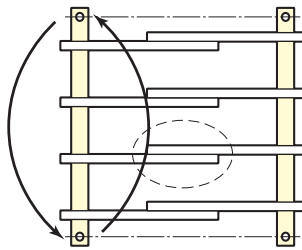

sb_045_b_1_x_cat.eps

Respecting the maximum distance between two supports ensures that the busbar supports are able to withstand the given short circuit current values. At these limits, distortion of the copper bars may occur. These deformations are permitted by standard IEC 61439-1 so long as they adhere to the insulation distances.

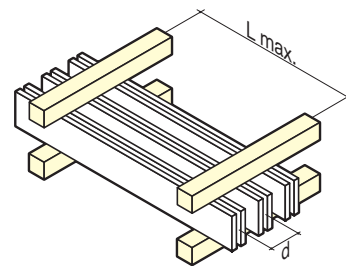

sb_021_b_1_x_cat.eps

Busbar supports

Edgewise mounting with fixed interphase

References

Support only

Use

To assemble a complete busbar support, please observe the multiple order quantity and order 1 spacer set

Type of busbar support	No. of poles	Number of busbars per phase	Thickness	Interphase	Interfixed	Available for order in multiples of	Support only Reference			
SB C 10	3 P	1 ... 2	5	75	250	2	5024 6300			
		1	10							
	4 P	1 ... 2	5	60			65	5024 6500		
		1		75				5024 6400		
	3 P	1	10	90			110	350	1	5024 6600
		2								
4 P	1 ... 2	5		110	90	5024 8300				
	3 P						1 ... 3	5024 8400		
SB C 15	4 P	1 ... 4		10	110	5024 7300				
							3 P	1 ... 3		5024 7400
SB C 20	4 P	1 ... 3	10	90	5024 5300					
						3 P	1 ... 3	5024 5500		
SB C 30	3 P	1 ... 3	10	185	525	1	5024 5300			
				130				5024 5500		

Spacer kit for support

Use

The spacer kit comprises 2 threaded rods, 2 insulating spacers cut to length according to bar height and 4 nuts.

Bar height (mm)	Available for order in multiples of	Reference
25	1	5020 2025
30		5020 2030
32		5020 2032
40		5020 2040
50		5020 2050
60		5020 2060
63		5020 2063
80		5020 2080
100		5020 2100
125		5020 2125
160		5020 2160
200		5020 2200



Accessories

Adjustable interfixed profiles

Use

Adjustable interfixed profiles allow you to install the busbar supports at a variable depth. For high-load busbars, we recommend the use of adjustable reinforced floating profiles.

Type of busbar support	For depth Min./max. (mm)	Pack qty	Reference
SB C 10 2 x 5 / 1 x 10	575 / 675	1	5024 9050
SB C 10 1 x 10 / 2 x 10	575 / 775		5024 9051
SB C 15			5024 9052
SB C 20			5024 9054
SB C 30			



Adjustable reinforced floating profiles

Use

With adjustable reinforced floating profiles, you can install busbar supports in varying depths in the case of high-load busbars (from 100 kg/ml).

Type of busbar support	For depth Min./max. (mm)	Available for order in multiples of	Reference
SB C 15	575 / 775	1	5024 9053
SB C 20			5024 9055
SB C 30			



Holding rod for SB C 15

Use

With the holding rods for SB C 15, you can install the support on a standard mounting profile in the case of high-load busbars (from 100 kg/ml).

Material: Stainless steel threaded rod.

Bar height (mm)	Available for order in multiples of	Reference
32	1	5020 1040
40		5020 1060
50		5020 1101
60		
80		5020 1125
100		
125		
160		



Busbar supports

Edgewise mounting with fixed interphase

Accessories (continued)

Bar holder

Use

The heels hold the busbars upright.

Type of busbar support	Number of bars	No. of poles	Available for order in multiples of	Reference
SBC 10	2 x 5 / 1 x 10	3	1	5024 9031
	2 x 5 / 1 x 10	4		5024 9041
	1 x 10 / 2 x 10	3		5024 9034
	1 x 10 / 2 x 10	4		5024 9044
SBC 15	1 to 3 x 10	3		5024 9032
	1 to 3 x 10	4		5024 9042
SBC 20	1 to 4 x 5 / 1 to 2 x 10	3		5024 9032
	1 to 4 x 5 / 1 to 2 x 10	4		5024 9042
SBC 30	1 to 3 x 10	3 / 4		5024 9033

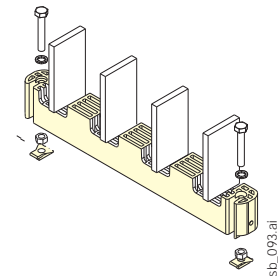

Installation corner piece

Use

Allows the holding heel to be placed on a support.

For cabinet Depth (mm)	To be ordered in multiples of	Reference
Min. 400	1	5024 9000
Min. 600	1	5024 9001

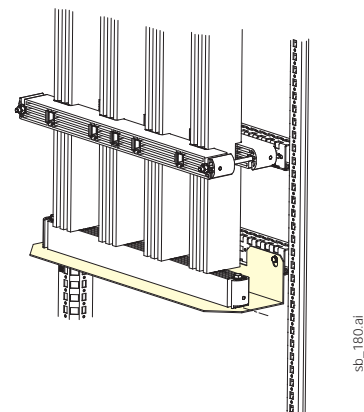

Fast connection of flexible bar or cables

Use

- Allows you to connect flexible bars or cables to busbars without having to drill the bars.
- Connect on 2 x 10 mm-thick bars placed side-by-side, 10 mm apart.
- For lug or flexible bar widths greater than 40 mm, use 2 connection accessories.
- Tightening with M10 screw, tightening torque 45Nm.
- For the connection, you will need: 1 tightening head nut and 1 screw adapted to the height of the bars.

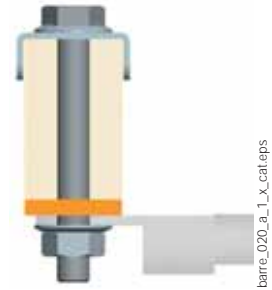

Type	Bar (mm)	Available for order in multiples of	Reference
M10 tightening head nut	All	12	5119 4423

Quick connection for busbars

Use

- Lock and connect busbars without drilling.
- Connect on 2 x or 3 x 10 mm-thick bars placed side-by-side.
- M10 screw tightening, 45 Nm torque. (to be ordered separately).

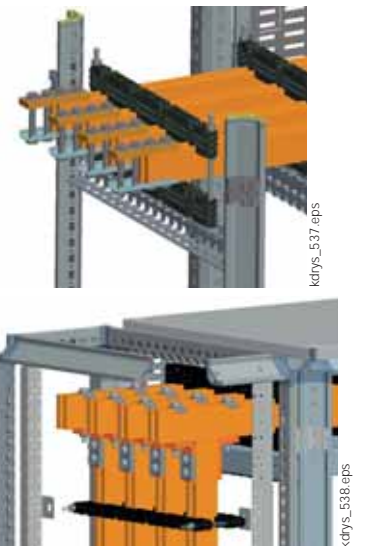

Current (A)	Number of bars / poles	Available for order in multiples of	Horizontal connection Reference	Vertical connection Reference
1600	2	1	5119 4411	5119 4401
3200	3		5119 4412	5119 4402
5000	3		5119 4413	5119 4403

Screws for quick connection

Type	Bar (mm)	Available for order in multiples of	Reference
M10 screw	30	100	5119 4503
	50		5119 4505
	60		5119 4506
	80		5119 4508
	100		5119 4510
	125		5119 4512
	160		5119 4513

Busbar supports

Edgewise mounting with fixed interphase

Characteristics

SB C 10

SB C 10 3 poles, distance between centres 75 mm, bar thickness 5 mm

	I_{cc} peak kA	25	48	63	84	110
	I_{cc} rms kA 1s	12.5	23	30	40	50
Bar width I	25	275	150	100	75	50
	32	300	150	125	75	75
	40	350	175	125	100	75
	50	400	200	150	125	75
	63	450	225	175	125	100
	80	500	250	200	150	125
	100	575	300	225	175	125
Bar width II	25	1000	650	500	375	300
	32	1000	750	575	425	350
	40	1000	850	650	475	375
	50	1000	950	725	550	350
	63	1000	1000	825	600	375
	80	1000	1000	950	625	400
	100	1000	1000	1000	650	425

SB C 10 3 poles, distance between centres 75 mm, bar thickness 10 mm

	I_{cc} peak kA	25	48	63	84	110
	I_{cc} rms kA 1s	12.5	23	30	40	50
Bar width I	30	800	425	325	225	175
	50	1000	550	425	300	225
	60	1000	600	450	325	275
	80	1000	700	550	400	325
	100	1000	800	600	450	350

SB C 10 3 poles, distance between centres 90 mm, bar thickness 10 mm

	I_{cc} peak kA	25	48	63	84	110
	I_{cc} rms kA 1s	12.5	23	30	40	50
Bar width I	30	825	425	325	250	200
	50	1000	550	425	300	250
	60	1000	625	475	350	275
	80	1000	1000	550	400	325
	100	1000	1000	625	450	375
Bar width II	30	1000	750	575	425	325
	50	1000	1000	750	550	375
	60	1000	1000	825	625	425
	80	1000	1000	975	725	450
	100	1000	1000	1000	825	450

SB C 10 4 poles, distance between centres 60 mm, bar thickness 5 mm

	I_{cc} peak kA	25	48	63	84	110
	I_{cc} rms kA 1s	12.5	23	30	40	50
Bar width I	25	275	150	100	75	50
	32	300	150	125	75	75
	40	350	175	125	100	75
	50	400	200	150	125	75
	63	450	225	175	125	100
	80	500	250	200	150	125
	100	575	300	225	175	125
Bar width II	25	1000	625	475	350	250
	32	1000	725	550	400	250
	40	1000	825	625	450	275
	50	1000	925	700	450	275
	63	1000	1000	800	475	300
	80	1000	1000	925	500	325
	100	1000	1000	1000	550	350

SB C 10 4 poles, distance between centres 65 mm, bar thickness 10 mm

	I_{cc} peak kA	25	48	63	84	110
	I_{cc} rms kA 1s	12.5	23	30	40	50
Bar width I	30	800	425	325	225	175
	50	1000	550	425	300	225
	60	1000	600	450	325	275
	80	1000	700	550	400	325
	100	1000	800	600	450	350

SB C 10 4 poles, distance between centres 90 mm, bar thickness 10 mm

	I_{cc} peak kA	25	48	63	84	110
	I_{cc} rms kA 1s	12.5	23	30	40	50
Bar width I	30	825	425	325	250	200
	50	1000	550	425	300	250
	60	1000	625	475	350	275
	80	1000	1000	550	400	325
	100	1000	1000	625	450	375
Bar width II	30	1000	750	575	425	325
	50	1000	1000	750	550	375
	60	1000	1000	825	625	425
	80	1000	1000	975	725	450
	100	1000	1000	1000	750	450

SB C 15

SB C 15 3 poles, distance between centres 110 mm, bar thickness 10 mm

	I_{cc} peak kA	84	110	154	165	176
	I_{cc} rms kA 1s	40	50	70	75	80
Bar width I	30	325	200	125	125	100
	50	425	250	175	150	150
	60	475	275	200	175	175
	80	550	325	225	200	200
	100	625	375	250	225	225
	125	700	400	275	250	250
	160	825	475	325	300	275
Bar width II	30	450	350	225	275	200
	50	575	475	325	275	250
	60	650	500	375	300	250
	80	750	600	375	325	250
	100	850	675	375	325	275
	125	975	775	400	350	300
	160	1000	925	425	375	325
Bar width III	30	625	475	350	300	250
	50	775	625	350	300	250
	60	1000	750	350	300	250
	80	1000	775	375	325	250
	100	1000	800	375	325	275
	125	1000	925	425	350	300
	160	1000	950	450	375	325

SB C1 5 4 poles, distance between centres 90 mm, bar thickness 10 mm

	I_{cc} peak kA	84	110	154	165	176
	I_{cc} rms kA 1s	40	50	70	75	80
Bar width I	30	275	225	125	125	100
	50	350	300	175	150	125
	60	375	350	175	175	150
	80	425	400	200	200	200
	100	475	450	250	225	225
	125	525	525	275	250	225
	160	625	600	325	300	275
	160	625	600	325	300	275
Bar width II	30	425	350	225	225	175
	50	575	450	275	225	200
	60	625	500	275	225	200
	80	725	575	275	250	225
	100	825	675	300	275	225
	125	950	750	350	300	225
	160	1000	825	400	325	275
	160	1000	825	400	325	275
Bar width III	30	575	475	275	225	200
	50	775	600	275	225	200
	60	850	600	275	225	200
	80	1000	650	275	250	225
	100	1000	675	300	275	225
	125	1000	750	350	300	250
	160	1000	825	400	325	275
	160	1000	825	400	325	275

SB C 20

SB C 20 3 poles, distance between centres 110 mm, thickness 10 mm

	I_{cc} peak kA	63	84	110	154	165	187	220	264
	I_{cc} rms kA 1s	30	40	50	70	75	85	100	120
Bar width I	50	775	575	475	325	300	250	225	175
	60	875	650	500	350	325	275	250	200
	80	1000	750	600	425	400	325	275	225
	100	1000	850	675	475	450	375	275	225
	125	1000	975	775	525	500	425	275	250
	160	1000	1000	875	600	575	500	300	250
Bar width II	50	1000	575	475	325	300	250	225	175
	60	1000	650	500	350	325	275	250	200
	80	1000	750	600	425	400	325	275	225
	100	1000	850	675	475	450	375	300	225
	125	1000	975	775	525	500	425	325	250
	160	1000	1000	875	600	575	500	350	250

SB C 20 4 poles, distance between centres 90 mm, thickness 10 mm

	I_{cc} peak kA	63	84	110	154	165	187	220	264
	I_{cc} rms kA 1s	30	40	50	70	75	85	100	120
Bar width I	50	750	550	450	300	275	225	225	150
	60	825	625	475	325	300	250	225	150
	80	975	725	575	400	375	300	250	175
	100	1000	825	650	450	425	350	275	175
	125	1000	950	750	500	475	400	300	200
	160	1000	1000	850	575	550	475	300	225
Bar width II	50	750	550	450	300	275	225	225	150
	60	825	625	475	325	300	250	225	150
	80	975	725	575	400	375	300	250	175
	100	1000	825	650	450	425	350	275	175
	125	1000	950	750	500	475	400	300	200
	160	1000	1000	850	575	550	475	300	225

Busbar supports

Edgewise mounting with fixed interphase

Characteristics (continued)

SB C 30

SB C 30 3 poles, distance between centres 185 mm, thickness 10 mm

	Icc peak kA	63	84	110	154	165	187	220	264
	Icc rms kA 1s	30	40	50	70	75	85	100	120
Bar width I	50	450	350	275	200	200	175	150	100
	60	500	375	300	225	200	175	150	125
	80	600	450	350	225	225	200	175	150
	100	650	500	400	275	250	225	200	175
	125	750	550	450	300	275	250	225	175
	160	825	625	500	350	300	275	250	200
	200	950	700	575	400	350	300	275	225
Bar width II	50	850	625	500	350	325	275	225	200
	60	925	700	550	375	350	300	250	225
	80	1000	800	650	450	400	350	300	250
	100	1000	925	725	500	450	400	350	275
	125	1000	1000	825	550	500	450	400	325
	160	1000	1000	925	625	575	525	450	375
	200	1000	1000	1000	700	650	575	500	375
Bar width III	50	1000	900	725	475	450	400	350	275
	60	1000	975	775	525	500	425	375	300
	80	1000	1000	925	625	575	500	425	350
	100	1000	1000	1000	700	650	575	475	350
	125	1000	1000	1000	800	725	650	550	375
	160	1000	1000	1000	900	825	750	575	375
	200	1000	1000	1000	1000	925	825	575	400

SB C 30 4 poles, distance between centres 130 mm, thickness 10 mm

	Icc peak kA	63	84	110	154	165	187	220	264
	Icc rms kA 1s	30	40	50	70	75	85	100	120
Bar width I	50	425	325	250	175	175	150	125	100
	60	475	350	275	200	175	150	125	100
	80	575	425	325	225	200	175	150	125
	100	625	475	375	250	225	200	175	150
	125	725	525	425	275	250	225	200	150
	160	800	600	475	325	275	250	225	175
	200	925	675	550	375	325	275	250	200
Bar width II	50	800	600	475	325	300	250	200	175
	60	850	650	525	350	325	275	225	200
	80	1000	775	600	425	375	325	275	225
	100	1000	875	675	475	425	375	325	250
	125	1000	975	775	525	475	425	375	275
	160	1000	1000	875	600	550	500	425	275
	200	1000	1000	1000	675	625	550	450	300
Bar width III	50	1000	825	650	425	400	375	325	225
	60	1000	900	725	475	450	400	325	225
	80	1000	1000	825	575	525	475	350	225
	100	1000	1000	950	650	600	525	375	250
	125	1000	1000	1000	750	575	575	425	275
	160	1000	1000	1000	850	775	600	425	275
	200	1000	1000	1000	975	825	625	450	275

Dimensions (mm)

SB C 10

2x 5 mm bar or 1x 10 mm bars

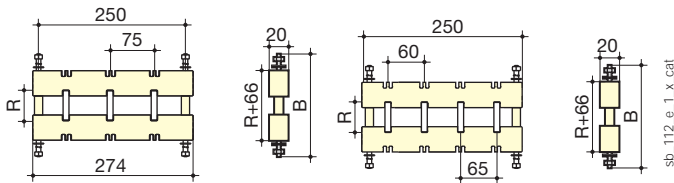

Fixed interphase:

- 3 poles 2 x 5 mm or 1 x 10 mm: 75 mm
- 4 poles bar thickness 5 mm: 60 mm, bar thickness 10 mm: 65 mm.

1 or 2 bars of 10 mm

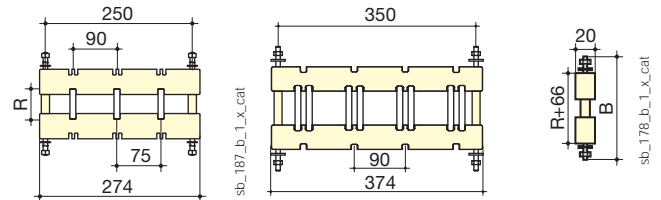

Fixed interphase:

- 3 poles 1 x 10 mm bar: 75 mm
- 2 x 10 mm bars per pole: 90 mm
- 4 poles 1 x or 2 x 10 mm bars: 90 mm.

SB C 15

3 poles 1 to 3x 10 mm bars

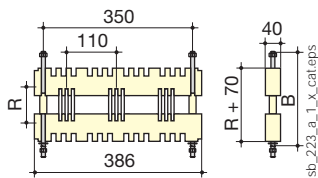

4 poles 1 to 3x 10 mm bars

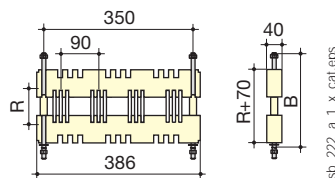

Fixed interphase:

- 3 poles: 110 mm
- 4 poles: 90 mm

SB C 20

3 poles 1 to 4x 5 mm bars and 1 to 2x 10 mm bars

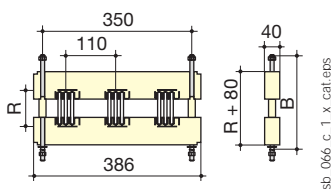

4 poles 1 to 4x 5 mm bars and 1 to 2x 10 mm bars

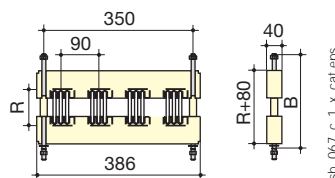

Fixed interphase:

- 3 poles: 110 mm
- 4 poles: 90 mm

SB C 30

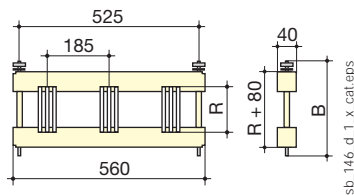
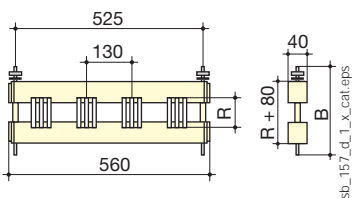

Fixed interphase:

- 3 poles: 185 mm
- 4 poles: 130 mm

Busbar supports

Edgewise mounting with adjustable interphase

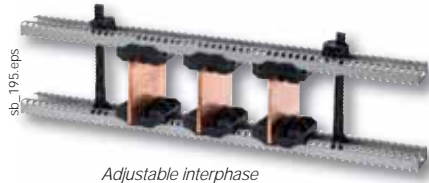

The solution for

- > Electrical distribution



Conformity with standards

- > IEC 61439-1
- > IEC 60865-1



Strong points

- > Insulating materials
- > Durability
- > Adaptability

Function

With SOCOMEC's insulating **bar supports** you can:

- mount and attach the busbars inside the electrical panel,
- cope with the forces experienced by the busbars during a short circuit.

Advantages

Insulating materials

Our range of SBC upright supports with adjustable interphase is made using thermoplastic. This very resistant material (reinforced fibreglass) is insulating so there are no risks in terms of clearance and creepage distances.

Amagnetism of assembly parts.

High resistance to damp heat (supplied "tropicalised").

Durability

Standard spacers are made of high-strength insulating material. If used in extreme conditions or for greater robustness, metal rod kits are available.

Adaptability

The studs are fixed onto profiles adapted to standard cabinet sizes.

Selection guide

Edgewise mounting

- Busbar supports with adjustable interphase

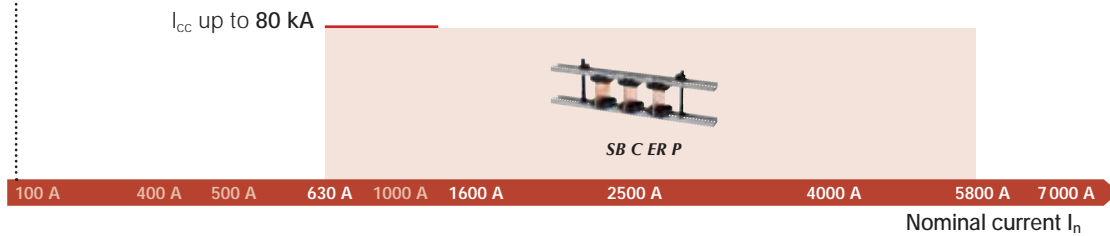

What you need to know

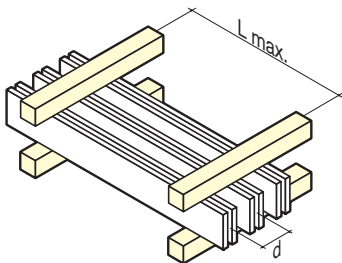

sb_021_b_1_x_cat.eps

Respecting the maximum distance between two supports ensures that the busbar supports are able to withstand the given short circuit current values. At these limits, distortion of the copper bars may occur. These deformations are permitted by standard IEC 61439-1 so long as they adhere to the insulation distances.

Busbar supports

Edgewise mounting with adjustable interphase

References

Full support

Designation	Thickness of busbar (mm)	Busbar width (mm)	Number of bars	No. of poles	Reference
Complete busbar supports	10	480	1 ... 3	4	5025 5135

Slot

Ordering guide

- For three poles, order: 6 x studs, 2 x rods, 2 x profiles.
- For four poles, order: 8 x studs, 2 x rods, 2 x profiles.

Slot	Bar thickness (mm)	Number of bars	No. of poles	Quantity	Available for order in multiples of	Reference
Slot for 5 mm bars	5	3	3 P	6 ⁽¹⁾	8	5025 5205
Slot for 5 mm bars	5	3	4 P	8 ⁽¹⁾	8	5025 5205
Slot for 10 mm bars	10	2	3 P	6 ⁽¹⁾	4	5025 5210
Slot for 10 mm bars	10	2	4 P	8 ⁽¹⁾	4	5025 5210
Slot for 10 mm bars	10	3	3 P	6 ⁽¹⁾	1	5025 5111
Slot for 10 mm bars	10	3	4 P	8 ⁽¹⁾	1	5025 5111

(1) Quantity required for 1 busbar support

(2) Kit of 2 profiles and 4 brackets.

Mounting accessories	Length (mm)	Quantity	Available for order in multiples of	Reference
Stud kit (bar height 25 to 200 mm)		2 ⁽¹⁾	4	5025 5100
Stud kit metal (bar height 0 to 100 mm)		2	2	5025 5101
Stud kit metal (bar height 0 to 200 mm)		2	2	5025 5102
380 mm profile	380	2 ⁽¹⁾	4	5025 5124
480 mm profile	480	2 ⁽¹⁾	4	5025 5125
580 mm profile	580	2 ⁽¹⁾	4	5025 5126
780 mm profile	780	2 ⁽¹⁾	4	5025 5128
2 m profile	2000		4	5025 5120
Profile for Prisma enclosure ⁽²⁾	525	1 ⁽¹⁾	1	5025 5130

Characteristics

5 mm slot / 3 bars and 10 mm slot / 2 bars

peak I _{sc}	L max. (support bars in mm) for					d min. (mm)	I _z (A) ⁽¹⁾
	82 kA	114 kA	152 kA	165 kA	187 kA		
rms I _{sc}	39 kA	52 kA	69 kA	75 kA	85 kA		
Bar x qty							
50 x 5 x 1	500	325	175	150		75	600
50 x 5 x 2	500	325	175	150	100	75	1050
50 x 5 x 3	500	325	175	150	100	75	1450
63 x 5 x 1	525	350	200	175		75	700
63 x 5 x 2	525	350	200	175	125	75	1250
63 x 5 x 3	525	350	200	175	125	75	1800
80 x 5 x 1	525	350	200	175	125	75	900
80 x 5 x 2	525	350	200	175	125	75	1550
80 x 5 x 3	525	350	200	175	125	75	2200
100 x 5 x 1	550	375	225	200	175	75	1100
100 x 5 x 2	550	375	225	200	175	75	1900
100 x 5 x 3	550	375	225	200	175	75	2650
125 x 5 x 1	575	400	250	225	200	75	1300
125 x 5 x 2	575	400	250	225	200	75	2350
125 x 5 x 3	575	400	250	225	200	75	3250
80 x 10 x 1	1000	750	350	300	200	75	1300
80 x 10 x 2	1000	750	350	300	200	75	2300
100 x 10 x 1	1000	750	375	325	225	75	1550
100 x 10 x 2	1000	775	375	325	225	75	2750
125 x 10 x 1	1000	775	375	325	225	75	1900
125 x 10 x 2	1000	775	375	325	225	75	3350
160 x 10 x 1	1000	775	400	350	250	75	2350
160 x 10 x 2	1000	800	400	350	250	75	4150

(1) Admissible busbar nominal current with a temperature inside the panel of between 45 °C and 80 °C.

For other mounting configurations, please contact us.

Characteristics (continued)

10 mm insert / 3 bars								
peak I_{sc}	L max. (bar supports in mm)						d (mm)	Iz (A) ⁽¹⁾
	63 kA	82 kA	114 kA	152 kA	165 kA	187 kA		
rms I_{sc}	30 kA	39 kA	52 kA	69 kA	75 kA	85 kA		
Bar x qty								
50 x 10 x 1	1000	1000	650	250	200	150	70	850
50 x 10 x 2	1000	1000	650	250	200	150	70	1550
50 x 10 x 3	1000	1000	650	250	200	150	70	2150
63 x 10 x 1	1000	1000	675	275	225	175	70	1050
63 x 10 x 2	1000	1000	675	275	225	175	70	1850
63 x 10 x 3	1000	1000	675	275	225	175	70	2600
80 x 10 x 1	1000	1000	700	300	250	175	70	1300
80 x 10 x 2	1000	1000	700	300	250	175	70	2300
80 x 10 x 3	1000	1000	700	300	250	175	70	3 200
100 x 10 x 1	1000	1000	725	325	275	175	70	1550
100 x 10 x 2	1000	1000	725	325	275	175	70	2750
100 x 10 x 3	1000	1000	725	325	275	175	70	3250
125 x 10 x 1	1000	1000	725	350	275	200	70	1900
125 x 10 x 2	1000	1000	725	350	275	200	70	3350
125 x 10 x 3	1000	1000	725	350	275	200	70	4650
160 x 10 x 1	1000	1000	750	350	300	200	70	2350
160 x 10 x 2	1000	1000	750	350	300	200	70	4150
160 x 10 x 3	1000	1000	750	350	300	200	70	5800

(1) Admissible busbar nominal current with a temperature inside the panel of between 45 °C and 80 °C
For other mounting configurations, please contact us.

Dimensions (mm)

Mounting

- 1 to 3 bars of 5 mm thickness, per pole.
- 1 to 3 bars of 10 mm thickness, per pole.
- Interphase distance: min. 70 mm and max. 200 mm.
- Use 2 studs positioned symmetrically on the extremity of the poles or between the outermost poles.

A (mm)	Cabinet (mm)
380	400
480	500
580	600
780	800

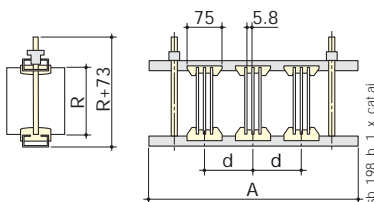

5 mm insert / 3 bars

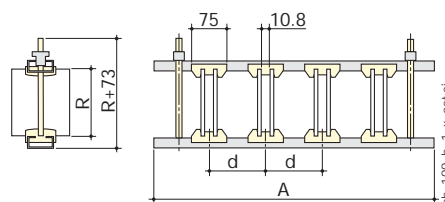

10 mm insert / 2 bars

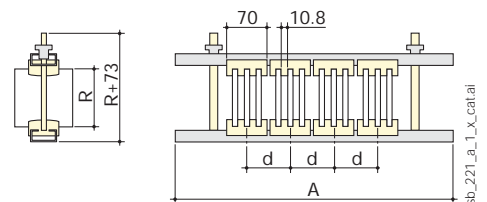

10 mm insert / 3 bars

Busbar supports

Flat mounting with fixed interphase



SB 7500

sb_136.eps

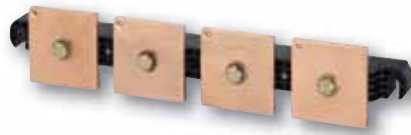

SB P 15

sb_123.eps

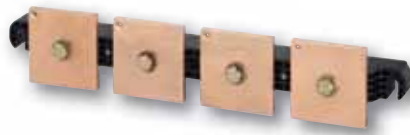

SB P 30

sb_123.eps

The solution for

- > Electrical distribution



Conformity with standards

- > IEC 61439-1
- > IEC 60865-1



Strong points

- > Space-saving

Function

Insulating busbar supports are for mounting busbars on a board.

Advantages

Space-saving

Flat mounted multipolar busbar supports are suitable for switchboard applications where space and footprint are paramount.

General characteristics

- High dielectric strength.
- High mechanical resistance.
- Amagnetism of assembly parts.
- High resistance to damp heat («tropicalised» as standard).

Selection guide

Flat mounting

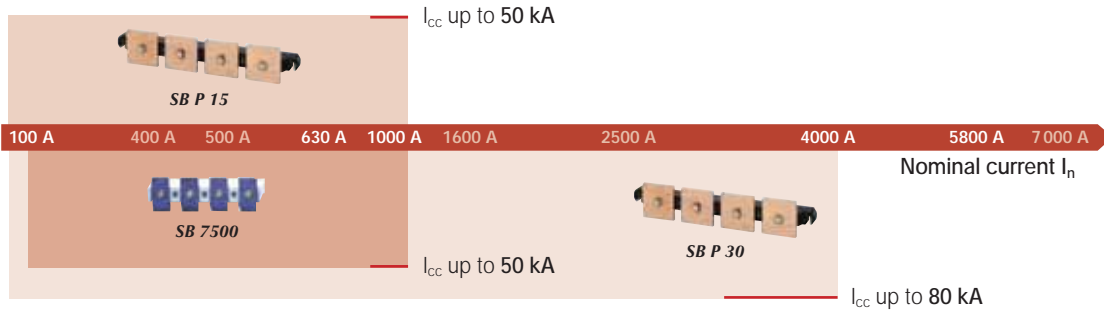

What you need to know

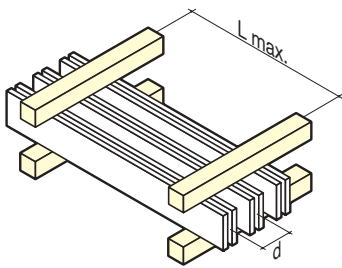

sb_021_b_1_x_catapps

Adhering to the maximum distance between two supports ensures that the busbar supports are able to withstand the given short circuit current values. At these limits, distortion of the copper bars may occur. These deformations are permitted by standard IEC 61439-1 so long as they adhere to the insulation distances.

Busbar supports

Flat mounting with fixed interphase

References

Support only

Bar support type	No. of poles	Insulation voltage (VAC)	Bar width (mm)	Pack qty	Reference
SB 7500	3 P	1000	40-50	1	5027 5310
SB 7500	4 P	1000	40-50	1	5027 5410
SB P 10	4 P	600	12-30	1	5026 0460
SB P 15	3 P / 4 P	1000	30 -80	1	5023 0150
SB P 30	3 P	1000	50-100	1	5023 0310
SB P 30	4 P	1000	50-80	1	5023 0410

Accessories

For SB P 15

Use

Mount the support and the bars to the support.

Fixing screws for support and bars	Available for order in multiples of	Reference
Fixing set	1	5023 0159

For SB P 30

Mounting bracket	Available for order in multiples of	Reference
2 mounting brackets	1	5024 9002

Bar fixing screws	Available for order in multiples of	Reference
Grub screws for mounting 1 bar	25	5119 4601
Headless screw for attaching 2 thicknesses of bar	25	5119 4602
Headless screw for attaching 3 thicknesses of bar	25	5119 4603

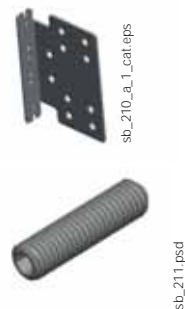

Characteristics

SB 7500

peak I_{sc}	L max. (support bars in mm) for						d (mm)	Iz (A)
	24 kA	48 kA	63 kA	82 kA	114 kA	152 kA		
rms I_{sc}	12 kA	23 kA	30 kA	39 kA	52 kA	69 kA		
Bar x qty							d (mm)	Iz (A)
50 x 5 x 1	1000	1000	950	725	525	450	75	600
50 x 5 x 2	1000	1000	1000	1000	975	850	75	1050

SB P 15

3 poles

peak I_{sc}	L max. (support bars in mm) for					d (mm)	Iz (A)
	24 kA	48 kA	63 kA	82 kA	114 kA		
rms I_{sc}	12 kA	23 kA	30 kA	39 kA	50 kA		
Bar x qty						d (mm)	Iz (A)
32 x 5 x 1	1000	1000	600	450	275	110	410
30 x 10 x 1	1000	1000	600	450	275	110	610
40 x 5 x 1	1000	1000	575	425	250	110	500
40 x 10 x 1	1000	1000	575	425	250	110	700
50 x 5 x 1	1000	1000	550	400	225	110	600
50 x 10 x 1	1000	1000	550	400	225	110	850
60 x 5 x 1	1000	1000	525	375	200	110	700
60 x 10 x 1	1000	1000	525	375	200	110	1000
80 x 5 x 1	1000	1000	500	350	175	110	900
80 x 10 x 1	1000	1000	500	350	175	110	1300

4 poles

peak I_{sc}	L max. (support bars in mm) for					d (mm)	Iz (A)
	24 kA	48 kA	63 kA	82 kA	114 kA		
rms I_{sc}	12 kA	23 kA	30 kA	39 kA	50 kA		
Bar x qty						d (mm)	Iz (A)
32 x 5 x 1	1000	1000	550	400	225	90	410
30 x 10 x 1	1000	1000	550	400	225	90	610
40 x 5 x 1	1000	1000	525	375	200	90	500
40 x 10 x 1	1000	1000	525	375	200	90	700
50 x 5 x 1	1000	1000	500	350	175	90	600
50 x 10 x 1	1000	1000	500	350	175	90	850
60 x 5 x 1	1000	1000	475	325	150	90	700
60 x 10 x 1	1000	1000	475	325	150	90	1000

Busbar supports

Flat mounting with fixed interphase

Characteristics (continued)

SB P 30

3 poles

peak I _{sc}	L max. (support bars in mm) for								d (mm)	Iz (A)
	63 kA	84 kA	110 kA	143 kA	165 kA	176 kA	187 kA	220 kA		
rms I _{sc}	30 kA	40 kA	50 kA	65 kA	75 kA	80 kA	85 kA	100 kA		
Bar x qty										
50 x 5 x 1	1000	950	525	300	225	200	175	130	123	600
63 x 5 x 1	1000	925	525	300	225	200	175	130	123	700
80 x 5 x 1	1000	900	500	300	225	175	175	125	123	900
80 x 5 x 2	1000	900	500	300	225	175	175	125	123	1550
50 x 10 x 1	1000	950	525	300	225	200	175	130	123	850
50 x 10 x 2	1000	975	525	300	225	200	175	135	123	1550
63 x 10 x 1	1000	925	525	300	225	200	175	130	123	1050
63 x 10 x 2	1000	950	525	300	225	200	175	130	123	1850
80 x 10 x 1	1000	900	500	300	225	175	175	125	123	1300
80 x 10 x 2	1000	925	500	300	225	200	175	125	123	2300
80 x 10 x 3	1000	950	525	300	225	200	175	130	123	3200

4 poles

peak I _{sc}	L max. (support bars in mm) for								d (mm)	Iz (A)
	63 kA	84 kA	110 kA	143 kA	165 kA	176 kA	187 kA	220 kA		
rms I _{sc}	30 kA	40 kA	50 kA	65 kA	75 kA	80 kA	85 kA	100 kA		
Bar x qty										
50 x 5 x 1	1000	1000	800	475	350	300	275	200	185	
63 x 5 x 1	1000	1000	800	475	350	300	275	200	185	
80 x 5 x 1	1000	1000	800	475	350	300	275	200	185	
80 x 5 x 2	1000	1000	800	475	350	300	275	200	185	
100 x 5 x 1	1000	1000	775	450	325	300	250	175	185	1100
100 x 5 x 2	1000	1000	775	450	325	300	250	175	185	1900
100 x 5 x 3	1000	1000	775	450	350	300	250	175	185	2650
50 x 10 x 1	1000	1000	800	475	350	300	275	200	185	
50 x 10 x 2	1000	1000	800	475	350	300	275	200	185	
63 x 10 x 1	1000	1000	800	475	350	300	275	200	185	
63 x 10 x 2	1000	1000	800	475	350	300	275	200	185	
80 x 10 x 1	1000	1000	800	475	350	300	275	200	185	
80 x 10 x 2	1000	1000	800	475	350	300	275	200	185	
80 x 10 x 3	1000	1000	800	475	350	300	275	200	185	
100 x 10 x 1	1000	1000	775	450	325	300	250	175	185	1550
100 x 10 x 2	1000	1000	775	450	350	300	250	175	185	2750
100 x 10 x 3	1000	1000	775	450	350	300	275	175	185	3850

Dimensions

SB 7500

No. of poles	A	B	C	J	R	T ₁	T ₂
3 P	220	38	35	75	52.5	11	6
4 P	295	38	35	75	52.5	11	6

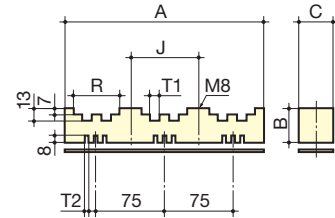

sb_149_a_1_x_cat

SB P 15

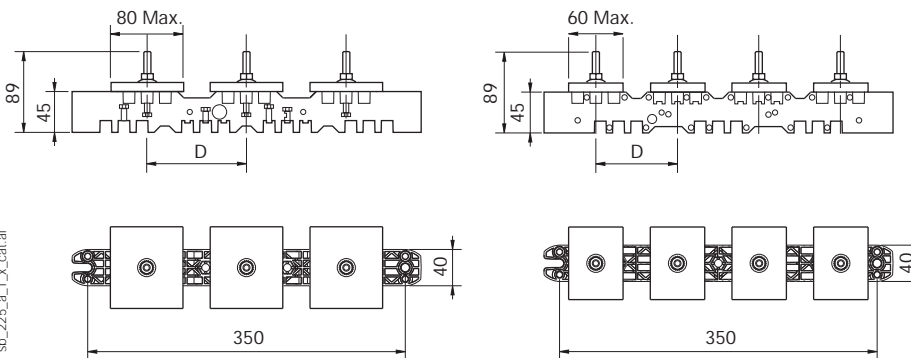

sb_225_a_1_x_cat.ai

SB P 30

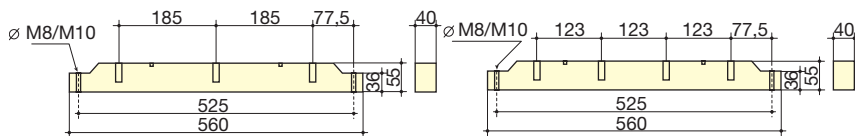

sb_154_c_1_x_cat

Busbar supports

Unipolar flat-mounted



sb_104.eps

Hexagonal insulators



SB 205-206

sb_117.eps



SB 3

sb_118.eps



SB 1 - SB 2

sb_108.eps

The solution for

- > Electrical distribution



Conformity with standards

- > IEC 61439-1
- > IEC 60865-1



Strong points

- > Insulating materials
- > Durability
- > Adaptability

sb_136.eps

Function

With SOCOMEC's insulating **bar supports** you can:

- mount and attach the busbars inside the electrical panel,
- cope with the forces experienced by the busbars during a short circuit.

Advantages

Insulating materials

Our range of SB P flat busbar supports with fixed interphase is made from insulating materials. This material poses no risks in terms of clearance and creepage distances.

Durability

Most bar supports have an M8 screw connection which provides outstanding robustness to the entire busbar structure.

Adaptability

The distance between the bar support attachment points is compatible with all commercially available enclosures.

Selection guide

Flat mounting



What you need to know

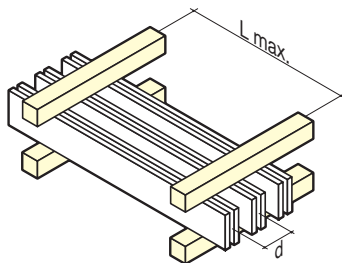

sb_021_b_1_x_cateps

Adhering to the maximum distance between two supports ensures that the busbar supports are able to withstand the given short circuit current values. At these limits, distortion of the copper bars may occur. These deformations are permitted by standard IEC 61439-1 so long as they adhere to the insulation distances.

Busbar supports

Unipolar flat-mounted

References

Hexagonal insulator

Height H (mm)	Thread M	Available for order in multiples of	Female-female Reference	Male-female Reference	Male-male Reference
16	M4	10	-	5038 1604	5039 1604
16	M5	10	-	5038 1605	5039 1605
20	M4	10	5031 2004	-	-
20	M6	10	5031 2006	-	-
25	M5	10	-	5038 2505	5039 2505
25	M6	10	5031 2506	5038 2506	5039 2506
30	M6	10	5031 3006	-	-
30	M8	10	5031 3008	-	-
35	M6	10	5031 3506	-	-
35	M8	10	5031 3508	5038 3508	5039 3508
35	M10	10	5031 3510	5038 3510	5039 3510
40	M8	10	5031 4008	-	-
40	M10	10	5031 4010	-	-
45	M8	10	5031 4508	-	-
45	M10	10	5031 4510	-	-
50	M8	10	5031 5008	5038 5008	5039 5008
50	M10	10	5031 5010	5038 5010	5039 5010
50	M12	10	5031 5012	-	-
60	M10	10	5031 6010	5038 6010	5039 6010
65	M10	10	5031 6510	-	-
70	M12	10	5031 7012	-	-

Support type SB

Support type	Insulation voltage (VAC)	Number of bars	Bar width (mm)	Available for order in multiples of	Reference
SB 1	690	1	20-25	6	5021 0110
SB 2	690	1	32-40	6	5022 0110
SB 3 without screws	690	1 ... 2	32-63	6	5023 0111
SB 3 pre-assembled	690	1 ... 2	32-63	6	5023 0110
SB 205	1000	1 ... 3	100	6	5022 5110
SB 306	1000	1 ... 3	160	6	5023 6110

Accessories

Grub screw

Length (mm)	Thread	To be ordered in multiples of	Reference
20	M6	20	5032 2006
20	M8	20	5032 2008
25	M6	20	5032 2506
25	M8	20	5032 2508
30	M6	20	5032 3006
30	M8	20	5032 3008
40	M8	20	5032 4008
40	M10	20	5032 4010
50	M12	20	5032 5012



sb_121_eps

Characteristics

Hexagonal insulator

Height H (mm)	Threading M	Rated voltage (V) AC/DC	Insulation voltage (VAC)		Mechanical characteristics (daN)		Max. tightening torque (Nm)
			50 Hz 1 min	Peak	Flexion	Traction	
16	M4	500	3000	5500	100	150	3
16	M5	500	3000	5500	100	150	6
20	M4	500	3000	5500	70	170	9
20	M6	500	3000	5500	100	190	8
25	M5	500	3000	5500	180	400	6
25	M6	500	3000	5500	170	370	12
30	M6	1000	6000	11000	200	650	22
30	M8	1000	6000	11000	360	800	40
35	M6	1400	9000	16000	230	720	25
35	M8	1400	9000	16000	380	900	42
35	M10	1400	9000	16000	320	800	44
40	M8	2000	12000	21500	620	1200	50
40	M10	2000	12000	21500	620	1100	60
45	M8	2000	12000	21500	550	1200	55
45	M10	2000	12000	21500	550	1100	65
50	M8	2000	12000	21500	650	1800	60
50	M10	2000	12000	21500	650	1700	70
50	M12	2000	12000	21500	660	1300	130
60	M10	2400	12000	27000	560	1600	85
65	M10	2400	12000	27000	750	1600	90
70	M12	2400	12000	27000	750	1500	135

Busbar supports

Unipolar flat-mounted

Characteristics (continued)

Hexagonal insulator

General characteristics

Height H (mm)	Threading	Bar x qty	L max. (support bars in mm) for					d min. (mm)	Iz (A) ⁽¹⁾	
			peak I _{sc}	24 kA	48 kA	63 kA	82 kA			114 kA
			rms I _{sc}	12 kA	23 kA	30 kA	39 kA			52 kA
20	M4	15 x 5 x 1	400	100				45	220	
20	M4	20 x 5 x 1	400	100				45	280	
25	M6	15 x 5 x 1	550	135				45	220	
25	M6	20 x 5 x 1	525	135				45	280	
25	M6	25 x 5 x 1	575	145				50	330	
30	M6	15 x 5 x 1	675	165				45	220	
30	M6	20 x 5 x 1	650	165				45	280	
30	M6	25 x 5 x 1	725	175	105			50	330	
30	M8	15 x 5 x 1	850	250	155			45	220	
30	M8	20 x 5 x 1	1000	250	155			45	280	
30	M8	25 x 5 x 1	1000	275	170	100		50	330	
35	M6	15 x 5 x 1	700	175	100			45	220	
35	M6	20 x 5 x 1	675	170	100			45	280	
35	M6	25 x 5 x 1	750	175	110			50	330	
35	M8	15 x 5 x 1	850	275	160			45	220	
35	M8	20 x 5 x 1	1000	275	160			45	280	
35	M8	25 x 5 x 1	1000	300	175	105		50	330	
35	M8	32 x 5 x 1	1000	325	175	110		55	410	
35	M10	20 x 5 x 1	850	200	125			45	280	
35	M10	25 x 5 x 1	950	225	135			50	330	
35	M10	32 x 5 x 1	1000	250	150			55	410	
40	M8	20 x 5 x 1	1000	325	175	110		45	280	
40	M8	25 x 5 x 1	1000	350	200	125		50	330	
40	M8	32 x 5 x 1	1000	375	225	135		55	410	
40	M10	20 x 5 x 1	1000	325	175	110		45	280	
40	M10	25 x 5 x 1	1000	350	200	125		50	330	
40	M10	32 x 5 x 1	1000	375	225	135		55	410	
45	M8	25 x 5 x 1	1000	425	250	150		50	330	
45	M8	32 x 5 x 1	1000	475	175	160		55	410	
45	M8	50 x 5 x 1	1000	625	350	200	110	75	600	
45	M10	25 x 5 x 1	1000	425	250	145		50	330	
45	M10	32 x 5 x 1	1000	450	250	160		55	410	
45	M10	50 x 5 x 1	1000	600	350	200	110	75	600	
50	M8	25 x 5 x 1	1000	450	250	155		50	330	
50	M8	32 x 5 x 1	1000	475	275	170		55	410	
50	M8	50 x 5 x 1	1000	650	375	225	115	75	600	
50	M10	32 x 5 x 1	1000	525	300	175		55	410	
50	M10	50 x 5 x 1	1000	700	400	225	125	75	600	
60	M10	50 x 5 x 1	1000	700	400	225	125	75	600	
65	M10	50 x 5 x 1	1000	775	450	250	135	75	600	

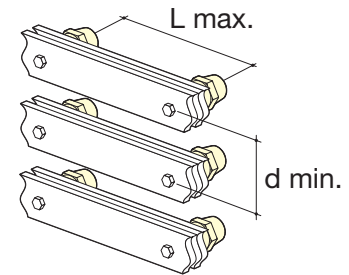

sb_T164_a_1_x_catt

(1) Admissible busbar nominal current with a temperature inside the panel of between 45°C and 80°C. For other mounting configurations, please contact us.

SB 1 - SB 2

Support	peak I_{sc}	L max. (support bars in mm) for					d min. (mm)	Iz (A) ⁽¹⁾
		24 kA	48 kA	63 kA	82 kA	114 kA		
	rms I_{sc}	12 kA	23 kA	30 kA	39 kA	52 kA		
Bar x qty								
SB 1	20 x 3 x 1	650	325	250	175	135	50	210
SB 1	20 x 5 x 1	850	425	325	250	175	50	280
SB 1	25 x 5 x 1	1000	525	400	300	200	50	330
SB 2	32 x 5 x 1	1000	750	575	450	300	70	410
SB 2	40 x 5 x 1	1000	950	700	550	400	70	500

(1) Admissible busbar nominal current with a temperature inside the panel of between 45°C and 80°C.
For other mounting configurations, please contact us.

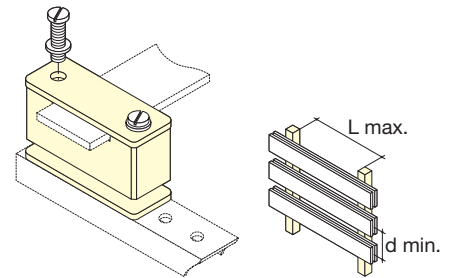

sb_150_a_1_x_cat

SB 3

peak I_{sc}	L max. (support bars in mm) for					d min. (mm)	Iz (A) ⁽¹⁾
	24 kA	48 kA	63 kA	82 kA	114 kA		
rms I_{sc}	12 kA	23 kA	30 kA	39 kA	52 kA		
Bar x qty							
32 x 5 x 2	1000	1000	925	700	500	70	580
40 x 5 x 2	1000	1000	1000	1000	1000	70	700
50 x 5 x 2	1000	1000	1000	925	675	75	850
63 x 5 x 2	1000	1000	1000	1000	1000	85	1000

(1) Admissible busbar nominal current with a temperature inside the panel of between 45°C and 80°C.
For other mounting configurations, please contact us.

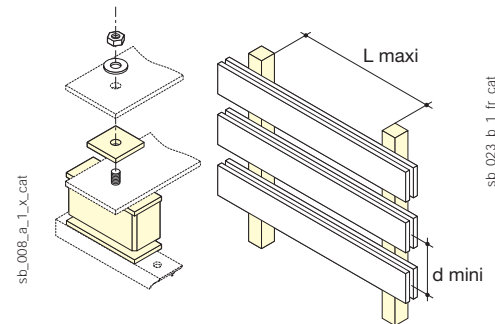

sb_008_a_1_x_cat

sb_023_b_1_fr_cat

SB 205 - SB 206

Support	Bar x qty	L max. (support bars in mm) for						d min. (mm)	Iz (A)
		peak I_{sc}	48 kA	63 kA	82 kA	114 kA	152 kA		
	rms I_{sc}	12.5 kA	23 kA	30 kA	40 kA	50 kA	75 kA		
SB 205	100 x 10 x 1	1000	800	475	250	150	125	125	1550
SB 205	100 x 10 x 2	1000	800	475	250	150	125	125	2750
SB 205	100 x 10 x 3	1000	800	475	250	150	125	125	3850
SB 306	160 x 10 x 1	1000	1000	625	350	200	150	175	2350
SB 306	160 x 10 x 2	1000	1000	625	350	200	150	175	4150
SB 306	160 x 10 x 3	1000	1000	625	350	200	150	175	5800

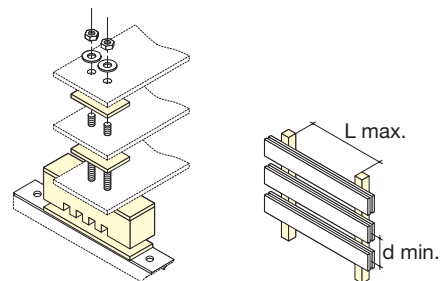

sb_152_a_1_x_cat

Busbar supports

Unipolar flat-mounted

Dimensions

Hexagonal insulator

Height H (mm)	Threading M	Depth		Diameter E (mm)	Length	
		D (mm)	Pu (mm)		W (mm)	L1 (mm)
16	M4	6	5	14	26	36
16	M5	6	5	14	26	36
20	M4	8	5.5	19	-	-
20	M6	8	5.5	19	-	-
25	M5				35	45
25	M6	10	7	25	35	45
30	M6	10	7	33	-	-
30	M8	12	9	33	-	-
35	M6	12	9	33	-	-
35	M8	12	9	33	50	65
35	M10	12	9	33	65	95
40	M8	15	12	40	-	-
40	M10	15	12	40	-	-
45	M8	15	12	41	-	-
45	M10	15	12	41	-	-
50	M8	20	17	46	75	100
50	M10	20	17	46	80	110
50	M12	20	17	46	-	-
60	M10	20	17	50	85	110
65	M10	20	17	55	-	-
70	M12	25	21	55	-	-

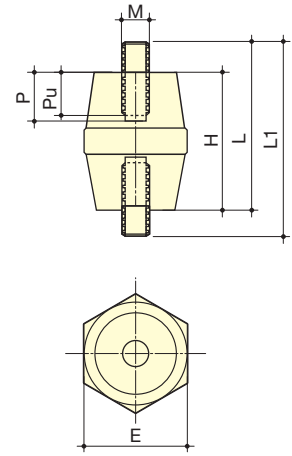

sb_224_a_1_fr_cat.eps

SB 1 – SB 2

Support	A	B	C	J
SB 1	50	23	20	34
SB 2	68	23	23.5	50

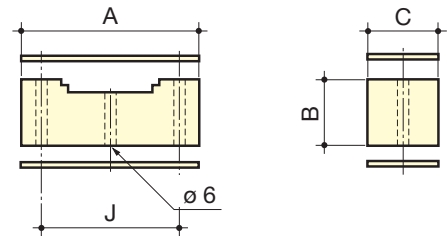

sb_014_c_1_x_cat

SB 3

Support	A	B	C	J
SB 3 without screws	65	32	28	36
SB 3 with screws	65	32	28	36

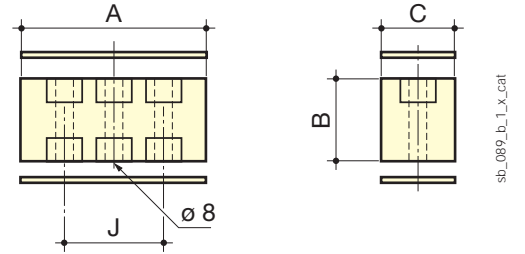

Dimensions

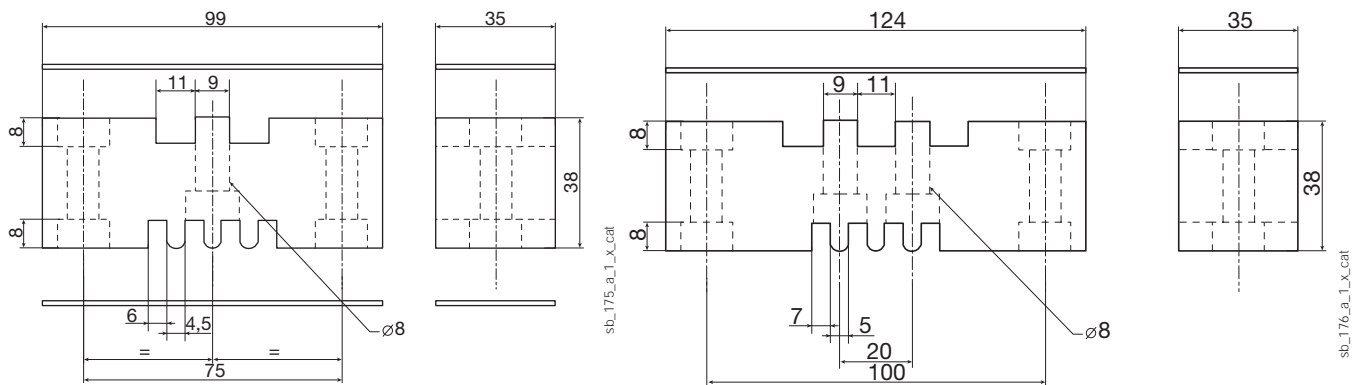

Busbar supports

Other supports

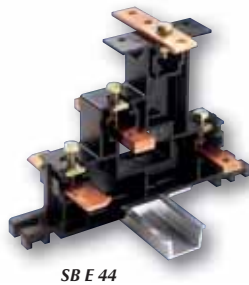

SB E 44

sb_038.eps



SB P 44

sb_170.eps

The solution for

- > Electrical distribution



Conformity with standards

- > IEC 61439-1
- > IEC 60865-1



Strong points

- > Insulating materials
- > Durability
- > Adaptability

Function

With SOCOMEC's insulating **bar supports** you can:

- mount and attach the busbars inside the electrical panel,
- cope with the forces experienced by the busbars during a short circuit.

Advantages

Insulating materials

Our range of busbar supports is made using thermoplastic. This very resistant material (reinforced fibreglass) is insulating so there are no risks in terms of clearance and creepage distances.

Durability

Most bar supports have an M8 screw connection which provides outstanding robustness to the entire busbar structure.

Adaptability

The distance between the bar support attachment points is compatible with all commercially available enclosures.

References

SB E 44 and SB P 44

Type of busbar support	Insulation voltage (VAC)	No. of poles	Bar width (mm)	Pack qty	Reference
SB E 44	690	4 P	15-32	1	5028 0410
SB P 44	690	4 P	20-32	1	5026 0450
Designation of SBE 44 accessories				Pack qty	Reference
270 mm long cap protection kit				1	5028 0411
420 mm long cap protection kit				1	5026 0412
620 mm long cap protection kit				1	5028 0413
Set of 20 protection screen adaption spacers				1	5026 0415

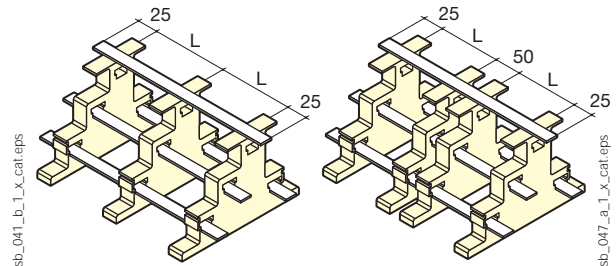

Type 1: Busbars including 3 (or more) equally spaced SB E 44 supports.

Type 2: Busbars including 3 (or more) SB E 44 supports with doubled intermediary supports.

Characteristics

SB E 44

Support	L max. (support bars in mm) for							Iz (A) ⁽¹⁾
	peak I _{sc}	10 kA	15 kA	24 kA	38 kA	48 kA	63 kA	
	rms I _{sc}	6 kA	9 kA	12 kA	19 kA	23 kA	30 kA	
Bar x qty								
Type 1	15 x 3 x 1	950	625	400	250	175		160
Type 1	15 x 5 x 1	1000	825	500	300	175		220
Type 1	15 x 6 x 1	1000	900	550	300	200		250
Type 1	15 x 8 x 1	1000	1000	650	300	200		290
Type 1	20 x 3 x 1	1000	825	525	300	175		210
Type 1	20 x 5 x 1	1000	1000	675	300	175		280
Type 1	20 x 6 x 1	1000	1000	750	300	175		310
Type 1	20 x 8 x 1	1000	1000	775	300	175		370
Type 1	32 x 5 x 1	1000	1000	675	250	170		410
Type 1	32 x 6 x 1	1000	1000	675	250	170		460
Type 2	15 x 3 x 1	950	625	400	250	200	150	160
Type 2	15 x 5 x 1	1000	825	500	325	250	175	220
Type 2	15 x 6 x 1	1000	900	550	350	275	200	250
Type 2	15 x 8 x 1	1000	1000	650	400	325	225	290
Type 2	20 x 3 x 1	1000	825	525	325	250	200	210
Type 2	20 x 5 x 1	1000	1000	675	425	325	225	280
Type 2	20 x 6 x 1	1000	1000	750	450	375	225	310
Type 2	20 x 8 x 1	1000	1000	850	525	375	225	370
Type 2	32 x 5 x 1	1000	1000	1000	525	325	175	410
Type 2	32 x 6 x 1	1000	1000	1000	525	325	175	460

SB P 44

peak I _{sc}	L max. (support bars in mm) for						d min. (mm)	Iz (A)
	10 kA	15 kA	24 kA	48 kA	63 kA	82 kA		
rms I _{sc}	6 kA	9 kA	12 kA	23 kA	30 kA	39 kA		
Bar x qty								
20 x 5 x 1	1000	1000	800	350	200	125	50	280
25 x 5 x 1	1000	1000	1000	350	200	125	50	330
32 x 5 x 1	1000	1000	1000	350	200	120	50	390
25 x 10 x 1	1000	1000	1000	350	200	125	50	500
30 x 10 x 1	1000	1000	1000	350	200	120	50	580
32 x 10 x 1	1000	1000	1000	350	200	120	50	610

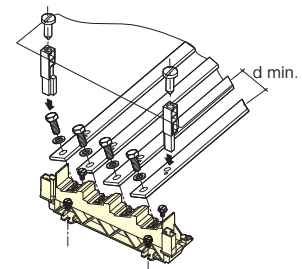

sb_165_c_1_x_cat

Dimensions (mm)

SB E 44

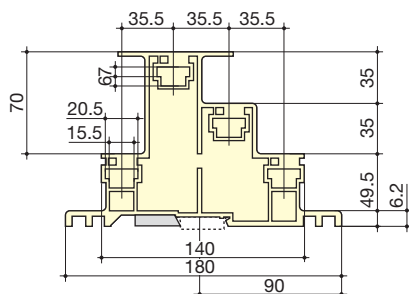

sb_036_e_1_x_cat

SB P 44

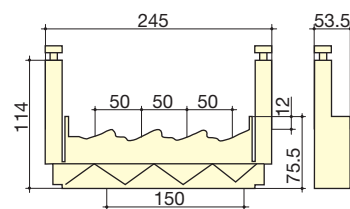

sb_147_b_1_x_cat

Distribution blocks

Distribution system



Single-pole distribution blocks

repair_043.eps



Multi-pole distribution bar

repair_044.eps



Distribution blocks for SOCOMEC power-switching devices

repair_020.psd

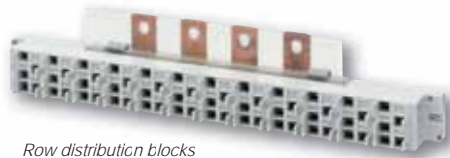

Row distribution blocks

repair_028.eps

The solution for

- > Electrical distribution



Strong points

- > Extensive range
- > Easy integration
- > IEC and UL range

Compliance with standards

- > IEC 61439-1
- > IEC 60947-7-1



- > UL 1953
- > UL 1059



Function

SOCOMECEC **distribution blocks** make it easy to connect conductors. They are mounted downstream of a load break switch, a changeover switch, a fuse switch or any protection device on the market.

Advantages

Extensive range

This extensive range has the right distribution system for every need:

- 13 single-pole models, 4 multi-pole models and 2 single-block models for copper and aluminium cables for either direct or plug connection
- 1 IP20 row distribution block
- 4 distribution block models for lug connection.

IEC and UL range

Our range of single-pole distribution blocks conforms to IEC and UL standards.

Easy integration

The compact size of the single-pole and multi-pole distributors for direct or plug connection ensures easy integration into the equipment.

Application

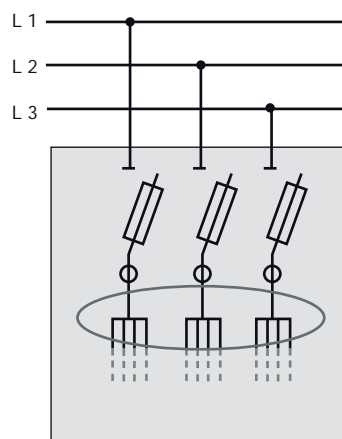

repair_045_a_1_x_cat.ai

IEC / UL single-pole distribution blocks

General features



- Material: tin-plated aluminium.
- For conductors: aluminium or copper.
- IP20 connection.
- L1, L2, L3, and N markings set by Allen key.
- DIN rail mounted.
- DIN rail attachment clip.
- Backplate mounted.
- Assembly clip for multiple distribution blocks.

References

Type	Rating (A)				References
	IEC		UL		
	Cu cable	Al cable	Cu cable	Al cable	
Type 1	80	63	85	65	54UL 1008
Type 2	125	100	115	90	54UL 1012
Type 3	175	135	175	135	54UL 1017
Type 4	250	200	255	205	54UL 1025
Type 5	415	36	380	310	54UL 1040

Dimensions

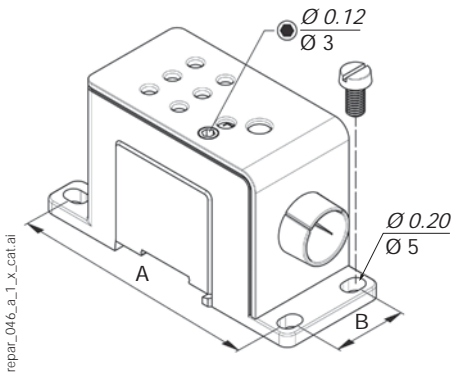

Type	Units	H x W x D	Mounting	
			A	B
Type 1	in	1.93 x 1.417 x 3.524	3.118	0.914
	mm	49 x 36 x 89.5	79.2	23.2
Type 2	in	1.93 x 1.417 x 3.524	3.118	0.914
	mm	49 x 36 x 89.5	79.2	23.2
Type 3	in	2.09 x 1.417 x 3.898	3.492	0.914
	mm	53 x 36 x 99	88.7	23.2
Type 4	in	2.39 x 2.126 x 4.488	4.063	1.622
	mm	60.7 x 54 x 114	103.7	41.2
Type 5	in	2.39 x 2.126 x 4.488	4.063	1.622
	mm	60.7 x 54 x 114	103.7	41.2

Electrical wiring and characteristics

Type	Solid/multi-core cables		Flexible/crimped-plug cables		Voltage according to IEC 60947-7-1		Voltage according to UL 1953		Short-circuit withstand		
	IEC connection	UL connection	IEC connection	UL connection	AC (V)	DC (V)	AC (V)	DC (V)	I _{cw} (kA)	I _{pk} (kA)	SCCR (kA)
Type 1	1 x 2.5 - 25 mm ²	14 - 3 AWG	1 x 2.5 - 25 mm ²	14 - 3 AWG	1000	1500	1000	1000	3	35	100
	6 x 2.5 - 10 mm ²	14 - 8 AWG	6 x 2.5 - 6 mm ²	14 - 10 AWG							
Type 2	1 x 2.5 - 50 mm ²	14 - 1 AWG	1 x 2.5 - 35 mm ²	14 - 2AWG							
	6 x 2.5 - 25 mm ²	14 - 4 AWG	6 x 2.5 - 16 mm ²	14 - 6 AWG							
Type 3	1 x 2.5 - 70 mm ²	14 - 2/0 AWG	1 x 2.5 - 50 mm ²	14 - 1/0 AWG							
	6 x 2.5 - 25 mm ²	14 - 4 AWG	6 x 2.5 - 16 mm ²	14 - 6 AWG							
Type 4	1 x 35 - 120 mm ²	2 - 250 kcmil	1 x 35 - 95 mm ²	2 - 4/0 AWG							
	6 x 2.5 - 35 mm ²	14 - 2 AWG	6 x 2.5 - 25 mm ²	14 - 4 AWG							
Type 5	1 x 70 - 240 mm ²	2/0 - 500 kcmil	1 x 70 - 185 mm ²	2/0 - 400 kcmil							
	6 x 2.5 - 35 mm ²	14 - 8 AWG	6 x 2.5 - 25 mm ²	14 - 4 AWG							

Distribution blocks

Distribution system

Single-pole IEC/UR distribution blocks

General features

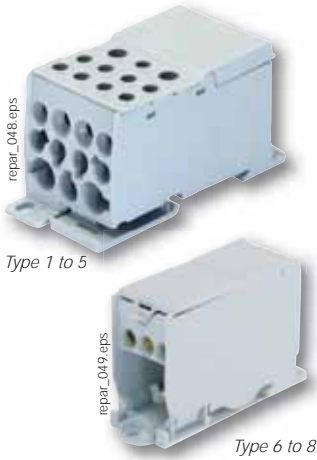

- Material: coated aluminium type 1 to type 5, copper for type 6 to type 8.
- For conductors: Aluminium or copper type 1 to type 5, copper for type 6 to type 8.
- IP20 connection.
- DIN rail mounted.
- Backplate mounted.

References

Type	Rating (A)				References
	IEC		UR		
	Cu cable	Al cable	Cu cable	Al cable	
Type 1	125	100	115	90	5411 1012
Type 2	125	100	115	90	5411 1013
Type 3	175	135	175	135	5411 1017
Type 4	250	200	255	-	5411 1025
Type 5	400	300	-	-	5411 1040
Type 6	125	-	-	-	5411 1011
Type 7	175	-	-	-	5411 1016
Type 8	250	-	-	-	5411 0124
Accessories					References
Connection for type 4					5410 0025
Connection for type 5					5410 0040

Attachments for mounting directly to load break switching device terminal

Dimensions

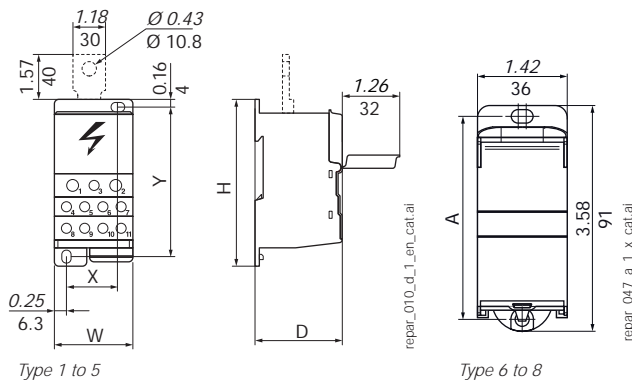

Distribution blocks with direct connection or IP20 jacks that plug into symmetrical DIN rail.

Type	Units	Dimensions H x W x D	Mounting	
			A	B
Type 1	in	2.91 x 1.06 x 1.81	2.44	0.157
	mm	74 x 27 x 46	62	4
Type 2	in	2.80 x 1.77 x 1.69	2.386	0.685
	mm	71 x 45 x 43	60.6	17.4
Type 3	in	2.80 x 1.77 x 1.69	2.386	0.685
	mm	71 x 45 x 43	60.6	17.4
Type 4	in	3.74 x 1.75 x 1.93	3.836	1.165
	mm	95 x 44.5 x 49	86	29.6
Type 5	in	3.74 x 1.75 x 1.93	3.836	1.165
	mm	95 x 44.5 x 49	86	29.6
Type 6	in	3.58 x 1.06 x 2.01	3.22	-
	mm	91 x 27 x 51	81.7	-
Type 7	in	3.58 x 1.42 x 2.01	3.22	-
	mm	91 x 36 x 51	81.7	-
Type 8	in	3.58 x 1.77 x 2.01	3.22	-
	mm	91 x 45 x 51	81.7	-

Electrical wiring and characteristics

Type	Solid/multi-core cables		Flexible/crimped-plug cables		Voltage according to IEC 60947-7-1		Voltage according to UL 1059		Short-circuit withstand	
	IEC connection	UL connection	IEC connection	UL connection	AC (V)	DC (V)	AC (V)	DC (V)	I _{cw} (kA)	I _{pk} (kA)
Type 1	1 x 10 - 35 mm ²	1 x 8 - 2 AWG	1 x 10 - 35 mm ²	1 x 8 - 2 AWG	1000	1500	600	600	4.2	30
	1 x 2.5 - 25 mm ²	1 x 14 - 4 AWG	1 x 2.5 - 16 mm ²	1 x 14 - 6 AWG						
	6 x 2.5 - 25 mm ²	6 x 14 - 4 AWG	6 x 2.5 - 16 mm ²	6 x 14 - 6 AWG						
Type 2	1 x 10 - 35 mm ²	1 x 8 - 2 AWG	1 x 10 - 35 mm ²	1 x 8 - 2 AWG						
	10 x 2.5 - 16 mm ²	10 x 14 - 4 AWG	10 x 2.5 - 10 mm ²	10 x 14 - 6 AWG						
	1 x 10 - 70 mm ²	1 x 8 - 2/0 AWG	1 x 10 - 50 mm ²	1 x 8 - 1/0 AWG						
Type 3	10 x 2.5 - 16 mm ²	10 x 14 - 4 AWG	10 x 2.5 - 10 mm ²	10 x 14 - 6 AWG						
	1 x 35 - 120 mm ²	1 x 2 - 250 kcmil	1 x 35 - 95 mm ²	1 x 2 - 4/0 AWG						
	2 x 2.5 - 35 mm ²	2 x 14/2 AWG	2 x 2.5 - 25 mm ²	2 x 14 - 4 AWG						
Type 4	5 x 2.5 - 16 mm ²	5 x 14 - 6 AWG	5 x 2.5 - 16 mm ²	5 x 14 - 6 AWG						
	4 x 2.5 - 10 mm ²	4 x 14 - 8 AWG	4 x 2.5 - 10 mm ²	4 x 14 - 8 AWG						
	1 x 95 - 185 mm ²		1 x 95 - 150 mm ²							
Type 5	2 x 2.5 - 35 mm ²		2 x 2.5 - 25 mm ²							
	5 x 2.5 - 16 mm ²		5 x 2.5 - 16 mm ²							
	4 x 2.5 - 10 mm ²		4 x 2.5 - 10 mm ²							
Type 6	2 x 10 - 35 mm ²		2 x 6 - 25 mm ²							
	2 x 2.5 - 25 mm ²		2 x 1.5 - 16 mm ²							
	6 x 1.5 - 16 mm ²		6 x 1.5 - 10 mm ²							
Type 7	2 x 25 - 70 mm ²		2 x 16 - 50 mm ²							
	3 x 2.5 - 25 mm ²		3 x 1.5 - 16 mm ²							
	8 x 1.5 - 16 mm ²		8 x 1.5 - 10 mm ²							
Type 8	1 x 35 - 120 mm ²		1 x 25 - 95 mm ²							
	1 x 1.5 - 50 mm ²		1 x 1.5 - 35 mm ²							
	4 x 1.5 - 16 mm ²		4 x 1.5 - 10 mm ²							
	8 x 2.5 - 25 mm ²		8 x 2.5 - 16 mm ²							

Multi-pole distribution blocks with IEC bars

General features



- Material: uncoated brass.
- For conductors: copper.
- DIN rail mounted.
- DIN rail attachment clip.
- Backplate mounted.
- Additional insulated bars.
- Reversible cap.



References

Type	Rating (A)	N° of poles	N° of connections	References
Type 1	100	3/4	7	5421 4010
Type 2	125		12	5421 4011
Type 3	125		15	5421 4012
Type 4	160		12	5421 4016
Additional lugs				References
7 connections				5421 1010
12 connections				5421 1012
15 connections				5421 1013

Dimensions

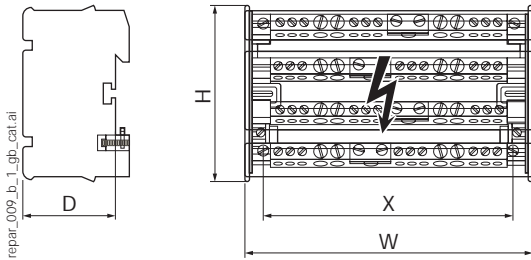

Type	Units	H x W x D	Mounting X
Type 1	in	4.11 x 2.84 x 1.96	2.126
	mm	104.5 x 72.2 x 49.7	54
Type 2	in	4.11 x 5.01 x 1.96	4.291
	mm	104.5 x 127.2 x 49.7	109
Type 3	in	4.11 x 6.90 x 1.96	4.646
	mm	104.5 x 175.2 x 49.7	118
Type 4	in	4.11 x 6.43 x 1.96	4.055
	mm	104.5 x 163.2 x 49.7	103

Electrical wiring and characteristics

Type	Solid/multi-core cables	Flexible/crimped-plug cables	Voltage according to IEC 60947-7-1		Short-circuit withstand	
			AC (V)	DC (V)	I _{cw} (kA)	I _{pk} (kA)
Type 1	2 x 2.5 / 25 mm ²	2 x 1.5 / 16 mm ²	690	1000	3	24
	5 x 1.5 / 16 mm ²	5 x 1.5 / 10 mm ²				
Type 2	1 x 10 / 35 mm ²	1 x 4 / 25 mm ²				
	7 x 2.5 / 25 mm ²	7 x 1.5 / 16 mm ²				
Type 3	4 x 1.5 / 16 mm ²	4 x 1.5 / 10 mm ²				
	1 x 10 / 35 mm ²	1 x 6 / 35 mm ²			4.2	28
	3 x 6 / 35 mm ²	3 x 4 / 25 mm ²				
Type 4	11 x 1.5 / 16 mm ²	11 x 1.5 / 10 mm ²				
	1 x 25 / 70 mm ²	1 x 16 / 50 mm ²	8.4	36		
	3 x 10 / 35 mm ²	3 x 4 / 25 mm ²				
8 x 2.5 / 25 mm ²	8 x 1.5 / 16 mm ²					

Earthing lug

References

Mounting by	N° of outgoing circuits per section (mm ²)	Material	L (mm)	To be ordered in multiples	Reference
2x M4 screws	10 x 16 + 2 x 35	Brass	120	10	5414 0120
2x M6 screws	41 x 16 + 2 x 35	Brass	470	10	5414 0470



Distribution blocks

Distribution system

IEC / UR single-block multi-pole distribution blocks

General features



Single-block multi-pole distribution block
175 A 3 P

- Material: uncoated brass for 125 A, tin-plated copper for 175 A.
- For conductors: aluminium or copper (175 only).
- IP20 connection.
- DIN rail mounted.

References

Rating (A)	N° of poles	Rating (A)				References
		IEC		UL		
		Cu cable	Al cable	Cu cable	Al cable	
125	4	125	-	-	-	5411 4112
175	3	175	135	175	135	5411 3017

Dimensions

Rating (A)	Units	H x W x D	Mounting	
			A	B
125	in	2.93 x 3.86 x 1.93	2.48	2.323 - 2.795
	mm	74.5 x 98 x 49	63	59 - 71
175	in	2.8 x 3.15 x 1.69	2.382	2.07
	mm	71 x 80 x 43	60.6	52.5

Electrical wiring and characteristics

Rating (A)	Solid/multi-core cables		Flexible/crimped-plug cables		Voltage according to IEC 60947-7-1		Voltage according to UL 1059		Short-circuit withstand	
	IEC connection	UL connection	IEC connection	UL connection	AC (V)	DC (V)	AC (V)	DC (V)	I _{cc} (kA)	I _{pk} (kA)
125	1 x 6 - 35 mm ²	-	1 x 6 - 25 mm ²	-	690	1000	600	600	4.2	25
	2 x 4 - 16 mm ²		2 x 4 - 10 mm ²							
	5 x 1.5 - 6 mm ²		5 x 1.5 - 6 mm ²							
175	1 x 10 - 70 mm ²	1 x 8 - 2/0 AWG	1 x 10 - 50 mm ²	1 x 8 - 1/0 AWG	1000	1500			11	30
	6 x 2.5 - 16 mm ²	6 x 14 - 4 AWG	6 x 2.5 - 10 mm ²	6 x 14 - 6 AWG						

Distribution row with IP20 connectors



References

Rating (A)	Length	With connecting cords ⁽¹⁾	I _{cc} (kA rms)	Reference
250 ⁽²⁾	1 row	Yes	10	5420 2426
250 ⁽²⁾	1 row	No	10	5421 2426

(1) Supplied with 6 mm² connecting cords, L = 120 mm, 12 black connectors, 12 blue connectors.
(2) Outgoing circuits should be split across the full number of outputs

Accessories

Cables

Rating (A)	Cable type	Length (mm)	Colour	To be ordered in multiples	Reference
40	6 mm ²	120	Blue	10	5421 1006
40	6 mm ²	120	Black	10	5421 1016
40	6 mm ²	320	Blue	10	5421 1106
40	6 mm ²	320	Black	10	5421 1116
63	10 mm ²	320	Blue	10	5421 1101
63	10 mm ²	320	Black	10	5421 1111

Plug-in connectors

Connector type	To be ordered in multiples	Reference
1.5 - 2.5 mm ²	20	5421 0025
4 - 6 mm ²	20	5421 0125

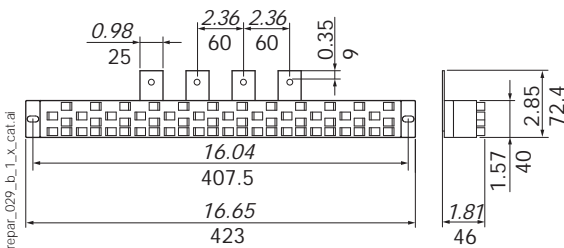

Lug connection

Multi-pole distribution block

References

Rating (A)	N° of poles	I _{cc} (kA rms)	N° of outgoing circuits per section (mm ²)	Reference
160	3 P	10	2 x 95 + 8 x 25	5412 3016
160	4 P	10	2 x 95 + 8 x 25	5412 4016
250	3 P	15	2 x 150 + 8 x 50	5412 3025
250	4 P	15	2 x 150 + 8 x 50	5412 4025
400	3 P	21	2 x 240 + 8 x 95	5412 3040
400	4 P	21	2 x 240 + 8 x 95	5412 4040
630	3 P	21	2 x 300 + 8 x 150	5412 3063
630	4 P	21	2 x 300 + 8 x 150	5412 4063

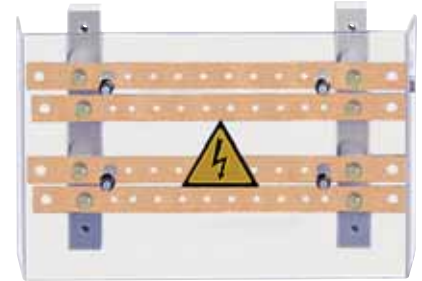

repar_007.eps

Dimensions (mm)

Rating (A)	N° of poles	Units	A	B	E	H	J	K	Ø L	P	R	T	Ø X	Ø X1	Y
160	3 P	in	6.06	11.26	2.87	1.83	4.80	8.15	0.26	1.42	0.79	0.16	0.35	0.24	2.13
		mm	154	286	73	46.5	122	207	6.5	36	20	4	9	6	54
160	4 P	in	7.48	11.26	2.87	1.83	6.22	8.15	0.26	1.42	0.79	0.16	0.35	0.24	2.13
		mm	190	286	73	46.5	158	207	6.5	36	20	4	9	6	54
250	3 P	in	8.27	12.09	3.27	2.26	1.97	8.7	0.28	1.97	0.98	0.16	0.43	0.31	2.20
		mm	210	307	83	57.5	50	222	7	50	25	4	11	8	56
250	4 P	in	8.27	12.09	3.27	2.26	1.97	8.7	0.28	1.97	0.98	0.16	0.43	0.31	2.20
		mm	260	307	83	57.5	100	222	7	50	25	4	11	8	56
400	3 P	in	11.06	14.76	4.57	3.25	2.56	10.63	0.31	2.56	1.26	0.20	0.57	0.33	3.23
		mm	281	375	116	82.5	65	270	8	65	32	5	14.5	8.5	82
400	4 P	in	13.62	14.76	4.57	3.25	5.12	10.63	0.31	2.56	1.26	0.20	0.57	0.33	3.23
		mm	346	375	116	82.5	130	270	8	65	32	5	14.5	8.5	82
630	3 P	in	10.67	17.24	4.61	3.56	2.56	13.11	0.31	2.56	1.57	0.24	0.57	0.41	3.27
		mm	271	438	117	90.5	65	333	8	65	40	6	14.5	10.5	83
630	4 P	in	13.62	17.24	4.61	3.56	5.12	13.11	0.31	2.56	1.57	0.24	0.57	0.41	3.27
		mm	346	438	117	90.5	130	333	8	65	40	6	14.5	10.5	83

Distribution block with lug connection, frontal protection against indirect contact.

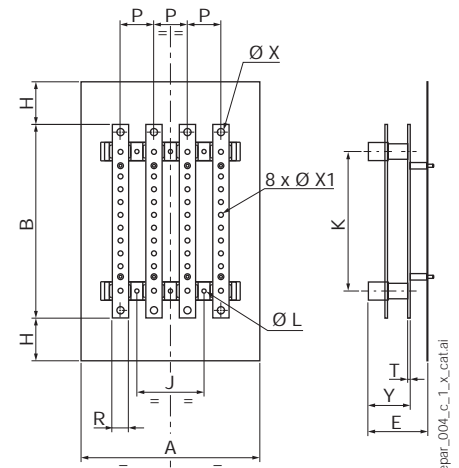

repar_004_c_1_x_cat.ai

Plug-in for 5 to 6.3 mm bars

References

Rating (A)	N° of poles	Reference
125/160	3 P	3699 3P16
	4 P	3699 6P16
250/400	3 P	3699 3P39
	4 P	3699 6P39
630/800	3 P	3699 3P80
	4 P	3699 6P80

Dimensions (mm)

Rating (A)	N° of poles	Units	A	B	C	D	E	F	G
125/160	3 P	in	3.90	0.79	M8	0.12	0.91	0.39	7.32
		mm	99	20		3	23	10	186
	4 P	in	3.90	0.79		0.12	0.91	0.39	9.76
		mm	99	20		3	23	10	248
250/400	3 P	in	4	0.79	M10	0.16	1.10	0.49	7.32
		mm	101.5	25		4	28	12.5	186
	4 P	in	4	0.98		0.16	1.10	0.49	9.76
		mm	101.5	25		4	28	12.5	248
630/800	3 P	in	4	0.98	M10	0.16	1.10	0.49	7.32
		mm	101.5	25		4	28	12.5	186
	4 P	in	4	0.98		0.16	1.10	0.49	9.76
		mm	101.5	25		4	28	12.5	248

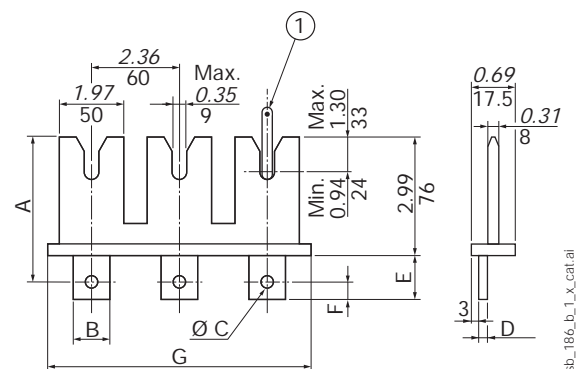

1. Bar thickness 5 to 6.3 mm.

sb_186_b_1_x_cat.ai

Distribution blocks

Distribution system

Lug connection (cont.)

Split throw multi-pole distribution block

References

Rating (A)	L (mm)	N° of poles	I _{cc} (kA rms)	No of brackets	Distribution block	
					Reference	Protective cover Reference
160	270	4 P	25	2	5028 0421	5028 0411
160	420	4 P	17	2	5028 0451	5028 0412
160	620	4 P	20	3	5028 0471	5028 0413
250	270	4 P	30	2	5028 0423	5028 0411
250	420	4 P	22	2	5028 0453	5028 0412
250	620	4 P	18	3	5028 0473	5028 0413
400	270	4 P	24	2	5028 0425	5028 0411
400	420	4 P	21	2	5028 0455	5028 0412
400	620	4 P	13	3	5028 0475	5028 0413

Type	Cond.	Reference
Spacer adaptor for protection covers	1	5028 0415

Dimensions (mm)

Rating (A)	N° of feeders	Units	A	Ø D	E	L	P	R
160	9	in	9.84	0.31	5.91	10.63	0.20	0.59
		mm	250	8	150	270	5	15
	15	in	15.75	0.31	11.81	16.54	0.20	0.59
		mm	400	8	300	420	5	15
	21	in	23.62	0.31	9.84	24.41	0.20	0.59
		mm	600	8	250	620	5	15
250	9	in	9.84	0.39	5.91	10.63	0.20	0.79
		mm	250	10	150	270	5	20
	15	in	15.75	0.39	11.81	16.54	0.20	0.79
		mm	400	10	300	420	5	20
	21	in	23.62	0.39	9.84	24.41	0.20	0.79
		mm	600	10	250	620	5	20
400	8	in	8.86	0.47	5.91	10.63	0.20	1.26
		mm	225	12	150	270	5	32
	14	in	14.76	0.47	11.81	16.54	0.20	1.26
		mm	375	12	300	420	5	32
	20	in	24.41	0.47	9.84	24.41	0.20	1.26
		mm	620	12	250	620	5	32

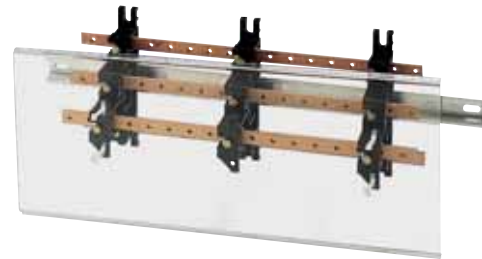

repar_012.eps

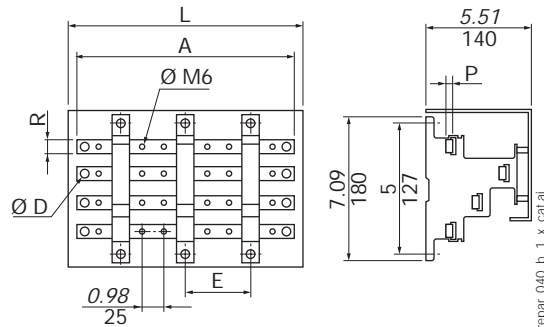

repar_040_b_1_x_catal

Split throw distribution block, with threaded holes, plugs into symmetrical DIN rail. Comes pre-mounted and without protective cap.

Disconnectable neutral

References

Rating (A)	Connection type	Reference
160	Lug connection	NB16 0000
250	Lug connection	NB25 0000
400	Lug connection	NB40 0000
630	Lug connection	NB63 0000



repar_030.eps

Dimensions (mm)

Rating (A)	Units	A	B	C	D	E	Max. width
160	in	3.94	0.98	3.35	4.61	1.77	1.26
	mm	100	25	85	117	45	32
250	in	5.91	0.98	4.72	6.81	1.77	1.26
	mm	150	25	120	173	45	32
400	in	6.93	0.98	5.91	7.87	2.56	2.17
	mm	176	25	150	200	65	55
630	in	8.27	0.98	6.30	9.45	2.56	2.95
	mm	210	25	160	240	65	75

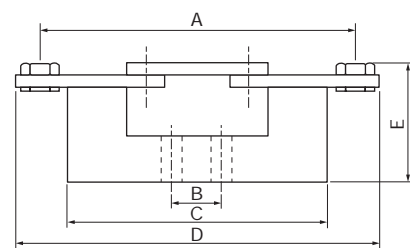

shunt_012_b_1_x_catal

Multi-pole distribution block for SIRCO

References

Rating (A)	N° of poles	I _{cc} (kA rms)	N° of outgoing circuits per section (mm ²)	Reference
160	3 P	10	1 x 95 + 8 x 25	5411 3016
	4 P	10	1 x 95 + 8 x 25	5411 4016
250	3 P	15	1 x 150 + 8 x 50	5411 3025
	4 P	15	1 x 150 + 8 x 50	5411 4025
400	3 P	21	1 x 240 + 8 x 95	5411 3040
	4 P	21	1 x 240 + 8 x 95	5411 4040
630	3 P	21	1 x 300 + 8 x 150	5411 3063
	4 P	21	1 x 300 + 8 x 150	5411 4063

Dimensions (mm)

Rating (A)	N° of poles	Units	A	B	E	H	K	P	R	T	Y
160	3 P	in	6.06	11.26	2.87	1.83	10.30	1.42	0.79	0.16	2.13
		mm	154	286	73	46.5	261.5	36	20	4	54
	4 P	in	7.48	11.26	2.87	1.83	10.30	1.42	0.79	0.16	2.13
		mm	190	286	73	46.5	261.4	36	20	4	54
250	3 P	in	8.27	12.09	3.27	2.26	10.98	1.97	0.98	0.16	2.20
		mm	210	307	83	57.5	279	50	25	4	56
	4 P	in	10.24	12.09	3.27	2.26	10.98	1.97	0.98	0.16	2.20
		mm	260	307	83	57.5	279	50	25	4	56
400	3 P	in	11.06	14.76	4.57	3.25	13.39	2.56	1.26	0.20	3.23
		mm	281	375	116	82.5	340	65	32	5	82
	4 P	in	13.62	14.76	4.57	3.25	13.39	2.56	1.26	0.20	3.23
		mm	346	375	116	82.5	340	65	32	5	82
630	3 P	in	10.67	17.24	4.61	3.56	16.16	2.56	1.57	0.24	3.27
		mm	271	438	117	90.5	410.5	65	40	6	83
	4 P	in	13.62	17.24	4.61	3.56	16.16	2.56	1.57	0.24	3.27
		mm	346	438	117	90.5	410.5	65	40	6	83



repair_020.psd

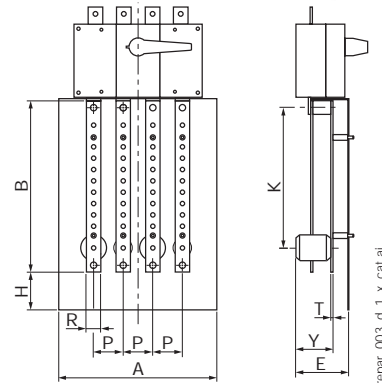

repair_003_d_1_x_cati.ai

Distribution block with lug connection, frontal protection against non-intentional contact (load break switching device not included).

Multi-pole distribution block for FUSERBLOC and SIRCO VM2

References

Rating (A)	Fuse size	N° of poles	Device	N° of outgoing circuits per section (mm ²)	Reference
100/125/160	22x58 / 00	3 P	FUSERBLOC	10x16 + 2x35 + 3xM6	5413 3016
		4 P		10x16 + 2x35 + 3xM6	5413 4016
160	0	3 P		10x16 + 2x35 + 3xM6	5413 3017
		4 P		10x16 + 2x35 + 3xM6	5413 4017
250	1	3 P		11 x M8	5413 3025
		4 P		11 x M8	5413 4025
400	2	3 P		11 x M8	5413 3040 ⁽¹⁾
		4 P		11 x M8	5413 4040 ⁽¹⁾
160 / 200		3 P	SIRCO VM2	10x16 + 2x35 + 3xM6	5413 3020
		4 P		10x16 + 2x35 + 3xM6	5413 4020

(1) *Distribution block compatible only with 400A Fuserbloc fuse reference 3xxx xx39

Dimensions (mm)

Rating (A)	N° of poles	Device	Units	A	B	E	H	K	P	R	T	Y
100 / 125 / 160	3 P	FUSERBLOC	in	4.33	10.24	2.40	0.79	9.17	1.42	0.79	0.16	1.54
			mm	110	260	61	20	233	36	20	4	39
	4 P		in	5.71	10.24	2.40	0.79	9.17	1.42	0.79	0.16	1.54
			mm	145	260	61	20	233	36	20	4	39
160	3 P		in	5.91	10.24	2.40	0.79	9.17	1.97	0.79	0.16	1.54
			mm	150	260	61	20	233	50	20	4	39
	4 P		in	7.87	10.24	2.40	0.79	9.17	1.97	0.79	0.16	1.54
			mm	200	260	61	20	233	50	20	4	39
250	3 P	in	7.68	13.39	2.64	0.59	11.81	2.36	1.26	0.20	1.77	
		mm	185	340	67	15	300	60	32	5	45	
	4 P	in	9.65	13.39	2.64	0.59	11.81	2.36	1.26	0.20	1.77	
		mm	245	340	67	15	300	60	32	5	45	
400	3 P	in	8.27	13.39	2.64	0.59	11.81	2.60	1.26	0.20	1.77	
		mm	210	340	67	15	300	66	32	5	45	
	4 P	in	10.83	13.39	2.64	0.59	11.81	2.60	1.26	0.20	1.77	
		mm	275	340	67	15	300	66	32	5	45	
160 / 200	3 P	SIRCO VM2	in	5.59	10.24	2.40	0.79	9.17	1.08	0.79	0.16	1.54
			mm	142	260	61	20	233	27.5	20	4	39
	4 P		in	5.59	10.24	2.40	0.79	9.17	1.08	0.79	0.16	1.54
			mm	142	260	61	20	233	27.5	20	4	39



repair_013.cps

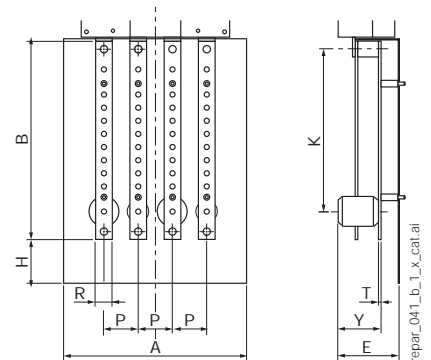

repair_041_b_1_x_cati.ai

By-Pass Double Line

socomec
Innovative Power Solutions

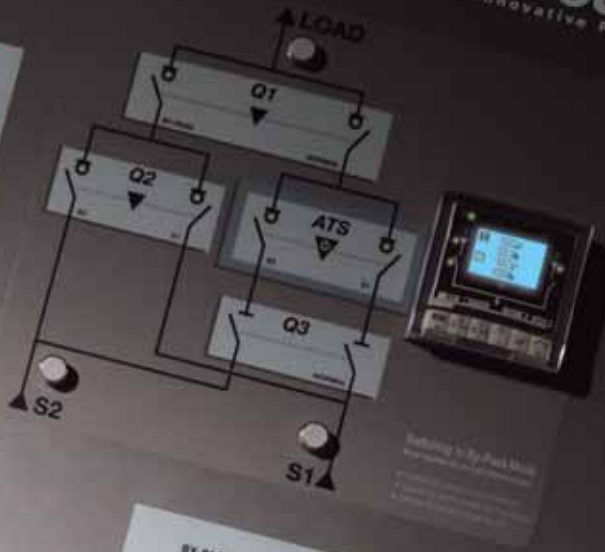

Integrated products & solutions

- Equipped enclosures and cabinets to suit all your applications [p. 484](#)
- Enclosed switches selection guide [p. 488](#)

Enclosed switches

Enclosed switches [p. 486](#)

Load break switches in insulated enclosures



COMO
Polycarbonate
20 to 125 A
[p. 491](#)



SIRCO
Polyester
160 to 630 A
[p. 492](#)

Load break switches in metallic enclosures



SIRCO M
Painted steel
20 to 100 A
[p. 492](#)



SIRCO
Painted steel
160 to 1600A
[p. 493](#)



SIRCO M
Stainless steel
32 to 100 A
[p. 494](#)

Fuse combination load break switches in insulated enclosures



FUSERBLOC
Polyester
50 to 160 A
[p. 499](#)



FUSERBLOC
Painted steel
32 to 800 A
[p. 499](#)

In metallic enclosures

Safety enclosures

Safety enclosures [p. 502](#)

Enclosed transfer switches

For critical applications



ATyS Bypass
Steel
40 to 3200 A
[p. 504](#)

Specific applications



Solutions for
medical locations
[p. 508](#)

Specific requirements

Socomec offers customisation and development of products to meet your every requirement. Contact your sales branch for more information.

Enclosed Products and Equipment to suit all your applications

The **specialist** in load breaking, switching, protection, metering and measurement, SOCOMEC designs and produces **standard and tailored integrated solutions**.

With our dual expertise (in products and solutions) we can offer you the electrical equipment you need for your systems, all under a **manufacturer's guarantee**.



IEC 61439

The **result of the long accumulation of extensive experience**, our **standard integrated solutions** bring you:

- **Fast implementation backed up** by a review of system limitations
- **Ease-of-use, without any risk of non-compliance errors**

Our solutions guarantee:

- **The safety and protection of people and goods**
- **Continuity of use**
- **Compliance with standards on products, assemblies and installations**

What you need to know!

SOCOMEK has an entire department at your service, dedicated to the design and production of specialist equipment.

This department is here to support you throughout your projects, including:

- Building specifications
- Budgets
- Planning
- Design and production
- Qualification and certification
- Support during installation and startup
- Training

Draw on our expertise and contact your local SOCOMEC branch.

Enclosed switches



SITE 301 A

Enclosed switches incorporate load-break switches with or without fuses, developed, qualified and certified for industrial electrical distribution and service sector networks.

They support the load-breaking, isolation and lockout of the mains power for all types of loads and can also be used as a general switch for equipment in various applications.

Safety enclosures



SITE 558 A

Safety enclosures are designed to be installed near a motor or a machine to **separate them from the power supply**. This includes manually operated, **padlockable load-break switches**, in the OFF position with a **visible and reliable display** of the switchgear's open position.

During preventive maintenance or inspection work, these enclosures ensure operator **safety against the accidental startup of electrical machines**.

For use in an explosive atmosphere (dust), use our ATEX model to prevent any explosion during the unit's opening/closing phases, which generate electrical arcs.

Enclosed Products and Equipment to suit all your applications

Enclosed Transfer Switch



SITE 375 A

Switching enclosures ensure the availability of electrical power in critical facilities (high-rises, public buildings, hospitals, IT or telecommunications centres, airports, industrial sites, etc.), operated manually or automatically to switch between a normal power source and a backup source (genset or auxiliary transformer) to cover in the event of failure.

For sites that require a power availability rate close to 100%, our **ATyS Bypass** solution offers dual redundancy during normal operation, service and maintenance work. With its capacity to resume Normal/Bypass channels, the ATyS Bypass solution allows the continued, seamless and safe use of your systems.

Solutions for medical premises



SITE 029 A

The availability of a reliable electrical power supply is vital to ensure continuity of care. There is no excuse today for power failures that can lead to life-or-death situations. Medical IT unearthing system cabinets ensure the availability of electrical power in medical centres (in accordance with standard IEC 60364-7-710).

The SOCOMEC medical IT cabinet range comes in three models and provides the solution for all your medical centre needs, with manufacturer's guarantee.

Enclosed switches

Enclosed load break switches and fuse combination load break switches

Switchgear systems are an essential part of your electrical system. Installed at every level of the distribution, they allow you to secure and isolate parts of the network or electrical equipment.

SOCOMEK load break switches in power distribution and machine control applications

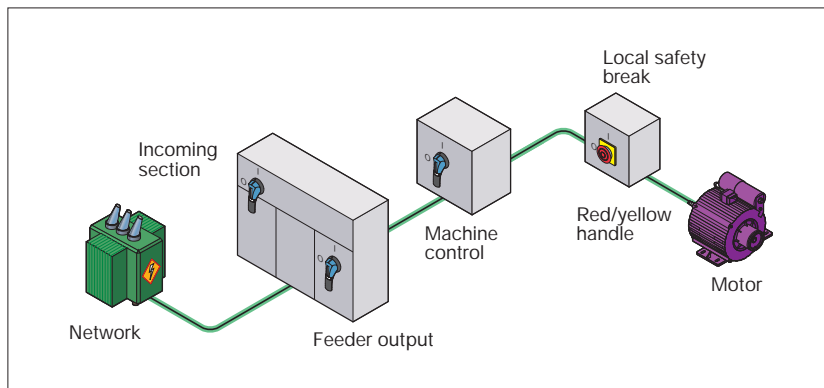

The solution for

- > Processing industry
- > Infrastructure
- > OEM

The advantages

- > Increased flexibility
- > Maintenance safety
- > Adaptable to every environment

A manufacturer's expertise

- > Active in the electrical switchgear market since 1922, Socomec is both a global leader and an undisputed benchmark reference.
- > Our enclosed solutions, with or without fuse protection, are suitable for a wide variety of commercial and industrial power distribution operating environments and applications. From 20 to 1600 A, to IEC or UL standards, we now have one of the widest ranges on the market.

Business sectors



Processing industry

- Cement plant - Quarries
- Steel plant
- Food processing industries



OEM

- HVAC - heating, ventilation and air-conditioning
- Lifting



Infrastructure

- Airports - Tunnels - Motorways
- Water treatment

Which product for which business?

Enclosure	Insulated		Metallic	
	Polycarbonate	Polyester	Painted sheet metal	Stainless steel
Rating	20 to 125 A	160 to 630 A	20 to 1600 A	32 to 100 A
Application				
Cement plant		++	+++	
Steel plant		++	+++	
Food processing	+	++		+++
Tunnels	+++	++	+	
Water treatment	++	+++		
HVAC	+++	++		
Lifting	+	++	+++	

The benefits of our range

Enclosed switches equipped with Socomec load break switches or fuse combination load break switches provide emergency breaking, breaking for mechanical maintenance, local safety isolation and fuse protection for any low voltage circuit.



Increased flexibility for more productivity

Controlling the power as close as possible to consumers makes operation and maintenance easy, autonomous and safe. This allows you to optimise the equipment's operating times.



Maintenance safety

Breaking close to the load means the system can reliably identify which circuits need to be disconnected.

On-load breaking and isolating, as well as the clear indication of the load break switch's position and the triple lock of the operating handle (in the open position) allows non-qualified persons to reliably and easily shutdown and isolate a supply circuit.

The locking of access (live or non current-carrying) to the enclosure's internal equipment can be managed to suit all kinds of safety procedures.



A solution to suit any environment

Available in 4 materials, the Socomec enclosed switch range can withstand most environmental constraints; protection against water and dust (IP), mechanical impact (IK) or corrosion.





Selection guide

Enclosed switches

Which application?





In which operating environment?

Electrical feature	Load break switches				
Enclosure	Insulated		Metallic		
					
Model	COMO 20 to 125 A <i>p. 491</i>	SIRCO 160 to 630 A <i>p. 492</i>	SIRCO M 20 to 100 A <i>p. 492</i>	SIRCO 160 to 1600 A <i>p. 493</i>	SIRCO M 32 to 100 A <i>p. 494</i>
Application					
Local breaking	•	•	•	•	•
Circuit protection					
Environmental risks					
Corrosion	+++	+++	+	+	+++
Chemical	++	++	+	+	+++
Mechanical impact	+	++	+++	+++	+++
Electrical characteristics					
Rated current: AC-22A, 400 V	20 ... 125 A	160 ... 630 A	20 ... 100 A	160 ... 1600 A	32 ... 100 A
Motor power AC-22A, 400 VAC (kW)	7.5 ... 45	80 ... 280	9 ... 45	80 ... 710	15 ... 45
Number of poles	3 / 4 / 6 / 8 P	3 / 4 P	3 / 4 P	3 / 4 P	3 / 4 P
Enclosure characteristics					
Material					
Polycarbonate	•				
Polyester		•			
Painted sheet metal			•	•	
Stainless steel					•
Protection degree	IP 65	IP 65	IP 65	IP 65	IP 65
Connection characteristics					
High-Low	•	•	•	•	
Low-Low	•	•	•	< 630 A	•
Minimum recommended connection section (mm ²)	1.5	50	1.5	50	1.5
Max. connection cross section (mm ²)	50	2 x 300	70	6 x 185	70

Which electrical feature ?

Which connection?

Fuse combination load break switches	
Insulated	Metallic
	
FUSERBLOC 50 to 160 A <i>p. 499</i>	FUSERBLOC 32 to 800 A <i>p. 499</i>
•	•
•	•
+++	+
++	+
++	+++
50 ... 160 A	32 ... 800 A
25 ... 80	15 ... 450
3 / 4 P	3 / 4 P
•	•
•	•
IP 55	IP 65
•	•
•	< 630 A
6	2.5
2 x 300	4 x 185

Enclosed switches

Load break switches

20 to 1600 A



COMO enclosure 20 to 125 A
Polycarbonate - IP65



SIRCO enclosure 160 to 630 A
Polyester - IP65



SIRCO M enclosure 32 to 100 A
Stainless steel - IP65



SIRCO M enclosure 20 to 100 A
Painted steel - IP65



SIRCO enclosure 160 to 1600 A
Painted steel - IP65

Function

Enclosed load break switches ensure the on-load breaking and making of circuits and safely isolate all low-voltage electrical circuits by providing protection against contact with live parts and environmental elements, such as dust, water and other hazards.

They enable the shutdown and isolation of the power supply as close to the equipment as possible.

Advantages

Safe operation

- Reliable lockout for safe maintenance procedures.
- On-load breaking.
- Ergonomic operating handle, available in red/yellow or black.
- Triple lock in OFF position.

Suitable for all kinds of environment

- Insulated enclosure for chemical and food processing applications, indoor or outdoor installation.
- Painted steel enclosure for areas at risk of mechanical impact.
- Stainless enclosure for food processing and pharmaceutical applications.

Easy setup

- Cable access top and/or bottom.
- Cable gland knockouts (≤ 125 A).
- Removable gland plates at top and bottom for steel enclosures ≥ 160 A.
- Plenty of room for cabling.

Extensive range

- Standard range
- Customised on request.



The solution for

- > OEM
- > Industries
- > Commercial buildings
- > Electrical distribution



Strong points

- > Safe operation
- > Suitable for all kinds of environment
- > Easy setup
- > Extensive range

Compliance with standards

- > IEC 60947-3
- > IEC 60364
- > EN 60947-3
- > EN 61439
- > EN 60204-1



Other products

- > Customised solutions available on request.

Load break switch in insulated enclosure

■ **COMO** in polycarbonate enclosure



como-enc_002 - 032 - 026 - 036

General characteristics

- From 20 to 125 A.
- 3, 4, 6, 8 poles.
- Yellow/red or grey/blue version.
- Triple lock in OFF position.
- Polycarbonate enclosure.
- Screw-on front.
- Degree of protection: IP65.
- Cable gland knock-outs at top, bottom and sides.
- Door interlocking when switch is ON.

Accessories

- Solid neutral pole (max. 1).
 - NO+NC or 2 NO auxiliary contact module for pre-break and signalling of positions 0 and I.
- Up to 2 auxiliary contact modules can be fitted to each product, one on each side of the switch.

References

Rating (A)	N° of poles	With blue handle	With red handle	Solid neutral pole ⁽¹⁾	Auxiliary contacts ⁽¹⁾	Enclosure		
						Size	H x W x D (mm)	Cable-in top and bottom (mm)
20	3 P	2115 3301	2115 3401	-	-	CPC 0	92 x 64 x 83	2 x Ø 25
	4 P	2115 4301	2115 4401					
25	3 P	2115 3302	2115 3402	2115 5005		CPC 1	163 x 100 x 115	2 x Ø 25 ⁽²⁾
	4 P	2115 4302	2115 4402					
32	3 P	2115 3303	2115 3403	2115 5005		CPC 2	200 x 146 x 150	2 x Ø 32 / 40 ⁽²⁾
	4 P	2115 4303	2115 4403					
	6 P	2115 6303	2115 6403					
40	3 P	2115 3304	2115 3404	2115 5007	1 AC NO+NC 2113 4001	CPC 1	163 x 100 x 115	2 x Ø 25 ⁽²⁾
	4 P	2115 4304	2115 4404					
63	3 P	2115 3306	2115 3406	2115 5007	1 AC 2 NO 2113 4002	CPC 2	200 x 146 x 150	2 x Ø 32 / 40 ⁽²⁾
	4 P	2115 4306	2115 4406					
	8 P	2115 8306	2115 8406					
80	3 P	2115 3308	2115 3408	2115 5009		CPC 3	304 x 214 x 182	2 x Ø 50 / 63 ⁽²⁾
	4 P	2115 4308	2115 4408					
100	3 P	2115 3309	2115 3409	2115 5011		CPC 2	200 x 146 x 150	2 x Ø 32 / 40 ⁽²⁾
	4 P	2115 4309	2115 4409					
125	3 P	2115 3312	2115 3412	2115 5011		CPC 3	304 x 214 x 182	2 x Ø 50 / 63 ⁽²⁾
	4 P	2115 4312	2115 4412					

(1) Max. configuration capacity: 1 solid neutral pole + 1 aux contact, or 2 aux contacts.

(2) In addition to top and bottom gland knock-outs, 2 x M20 knock-outs are included on each side of the enclosure for CPC 1 thru CPC 3.

Configurations

Possible configurations

Solid neutral pole and auxiliary contact accessories can be fitted to the left and/or right side of the COMO switch. Note that only one neutral pole can be fitted. See the below table for details.

Accessory 1 (left)	COMO switch	Accessory 2 (right)
Aux. contact	3/4/6/8P	Aux. contact
Solid neutral	3/4/6/8P	Aux. contact
Aux. contact	3/4/6/8P	Solid neutral

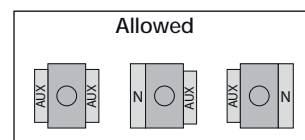
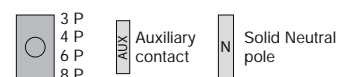

colref_687_a_en.ai

Enclosed switches

Load break switches

20 to 1600 A

Load break switch in insulated enclosure

■ **SIRCO** in polyester enclosure



General characteristics

- From 160 to 630 A.
- 3 poles + unswitched neutral, 4 poles.
- Black handle (red/yellow on request).
- Triple lock in OFF position.
- Polyester enclosure.
- Screw-on front.
- Colour: RAL 7035.
- Degree of protection: IP65.
- Wall-mounted, 4 brackets included.

Accessories

- NO/NC auxiliary contact.
- Terminal screen.

References

Rating (A)	N° of poles	With black handle	Auxiliary contacts	Protective screen	Enclosure	
					Size	H x W x D (mm)
160	3 P + N	3116 5016	1 st AC NO/NC 2699 0031	2698 3012	CP 32	360 x 270 x 171
	4 P	3116 4016		2698 4012		
250	3 P + N	3116 5025	2 nd AC 2 NO/NC 2699 0032	2698 3020	CP 53	540 x 360 x 171
	4 P	3116 4025		2698 4020		
400	3 P + N	3116 5040	2699 0032	2698 3050	CP 75	720 x 540 x 201
	4 P	3116 4040		2698 4050		
630	3 P + N	3116 5063		2698 3050		
	4 P	3116 4063		2698 4050		

Load break switch in metallic enclosure

■ **SIRCO M** in painted steel enclosure



General characteristics

- From 20 to 100 A.
- 3 poles + solid neutral.
- Red/yellow or black handle.
- Triple lock in OFF position.
- Painted steel enclosure.
- Hinged door or screw-on cover.
- Colour: RAL 7035.

- Pre-punched cable gland knockouts at top and bottom.
- Degree of protection: IP65.

Accessories

- Switched 4th pole (max. 1).
- NO+NC or 2 NO auxiliary contact (max. 2).
- Terminal shrouds.
- Wall mounting brackets.

References

Rating (A)	N° of poles	With black handle	With red/yellow handle	Switched 4 th pole	Auxiliary contacts	Terminal shroud	Wall brackets	Enclosure		
								Size	H x W x D (mm)	Cable-in top and bottom (mm)
20	3 P + N	3032 5002 ⁽¹⁾	3032 5102 ⁽¹⁾	2200 1001	1 AC NO + NC 2299 0001	2294 3005 (3 P) 2294 1005 (1 P)	3031 0011	CT 21	200 x 150 x 120	2 x Ø 25 + 2 x Ø 32 + Ø 16
	3 P + N	3032 5202 ⁽²⁾	3032 5302 ⁽²⁾					CT 21a		
32	3 P + N	3032 5003 ⁽¹⁾	3032 5103 ⁽¹⁾	2200 1003	2299 0001	2294 3009 (3 P) 2294 1009 (1 P)	3031 0011	CT 21	200 x 150 x 120	2 x Ø 25 + 2 x Ø 32 + Ø 16
	3 P + N	3032 5203 ⁽²⁾	3032 5303 ⁽²⁾					CT 21a		
63	3 P + N	3032 5006 ⁽¹⁾	3032 5106 ⁽¹⁾	2200 1006	2299 0011	2294 3016 (3 P) 2294 1011 (1 P)	3031 0011	CT 21	200 x 150 x 120	2 x Ø 25 + 2 x Ø 32 + Ø 16
	3 P + N	3032 5206 ⁽²⁾	3032 5306 ⁽²⁾					CT 21a		
100	3 P + N	3032 5010 ⁽¹⁾	3032 5110 ⁽¹⁾	2200 1010				CT 32	300 x 200 x 120	Ø 32 + 2 x Ø 50 + Ø 16
	3 P + N	3032 5210 ⁽²⁾	3032 5310 ⁽²⁾					CT 32a		

(1) Hinged door closed with double bar locks.

(2) Front panel screw-on.

Load break switch in metallic enclosure (continued)

■ **SIRCO** in painted steel enclosure



coif_566_front.psd

General characteristics

- From 160 to 1600 A.
- 3 poles + solid neutral , 4 poles.
- Black handle (red/yellow on request).
- Triple lock in OFF position.
- Painted steel enclosure.
- Hinged door with double bar locking.
- Colour: RAL 7035.
- Cable gland plates: top and bottom.
- Degree of protection: IP65.
- Wall-mounted, 4 brackets included.

Accessories

- NO/NC auxiliary contact.
- Terminal screen.

References

Rating (A)	N° of poles	Handle Black Reference	Auxiliary contacts	Protective screen (top or bottom)	Enclosure			
					Size	H x W x D (mm)	Cable-in top and bottom (mm)	
160	3 P + N	3032 5016	1 st AC NO/NC 2699 0031 2 nd AC 2 NO/NC 2699 0032	2698 3012	CT 43	400 x 300 x 210	180 x 100	
	4 P	3032 4016		2698 4012				
250	3 P + N	3032 5025		2698 3020				
	4 P	3032 4025		2698 4020				
400	3 P + N	3032 5040		2698 3050				
	4 P	3032 4040		2698 4050				
630	3 P + N	3032 5063		2698 3050				
	4 P	3032 4063		2698 4050				
800	3 P + N	3032 5080		2698 3080				
	4 P	3032 4080		2698 4080				
1250	3 P + N	3032 5084		2698 3120				
	4 P	3032 4084		2698 4120				
1600	3 P + N	3032 5088		2698 3120				
	4 P	3032 4088		2698 4120				
					CT 66	600 x 600 x 300	380 x 100	
					CT 86	800 x 600 x 350	560 x 100	
					CT 128	1200 x 800 x 300	660 x 100	

Enclosed switches

Load break switches

20 to 1600 A

Load break switch in metallic enclosure (continued)

■ **SIRCO M** in stainless steel enclosure



General characteristics

- 32 to 100 A.
- 3 poles + solid neutral.
- Black or red/yellow handle.
- Triple lock in OFF position.
- Brushed stainless steel enclosure 304 (please ask for other options).
- Degree of protection: IP65.
- Pre-punched cable gland knockouts at bottom.
- Hinged door with double bar locking.

Accessories

- Switched 4th pole (max. 1).
- NO+NC or 2 NO auxiliary contact (max. 2).
- Wall mounting brackets.

References

Rating (A)	N° of poles	With black handle	With red/yellow handle	Switched 4 th pole	Auxiliary contacts	Terminal shroud	Set of stainless steel brackets	Enclosure		
								Size	H x W x D (mm)	Cable-in bottom (mm)
32	3 P + N	3032 8003	3032 8103	2200 1003	1 AC NO + NC 2299 0001 1 AC 2 NO 2299 0011	2294 3005 (3 P) 2294 1005 (1 P)	3031 0012	CI 21	200 x 150 x 120	2 x Ø 25 + 2x Ø 32 + Ø 16
63	3 P + N	3032 8006	3032 8106	2200 1006		2294 3009 (3 P) 2294 1009 (1 P)				
100	3 P + N	3032 8010	3032 8110	2200 1010		2294 3016 (3 P) 2294 1011 (1 P)				
								CI 32	300 x 200 x 120	Ø 32 + 2 x Ø 50 + Ø 16

Characteristics

Electrical features according to IEC 60947-3

		COMO							
		20 A	25 A	32 A	40 A	63 A	80 A	100 A	125 A
Thermal current I_{th} (40°C)									
Enclosed thermal current I_{th} (35°C) (A)		20	25	32	40	63	80	100	125
Enclosed thermal current I_{th} (50°C) (A)		17	22	28	35	54	69	86	108
Rated insulation voltage U_i (V)		690	690	690	690	690	690	690	690
Rated impulse withstand voltage U_{imp} (kV)		4	6	6	6	6	6	6	6
Rated operational currents I_e (A)									
Rated voltage	Utilisation category								
400 VAC	AC-22 A / AC-22 B	20	25	32	40	63	80	100	125
400 VAC	AC-23 A / AC-23 B	15	20	22	40	44	53	70	84
690 VAC	AC-22 A / AC-22 B		12	13	18	22	23.5	34	41
690 VAC	AC-23 A / AC-23 B		9.5	11.5	13	17.5	22	25.5	35
Operational power in AC-23 (kW) without pre-break auxiliary contact									
400 VAC without pre-break AC (kW) ⁽¹⁾		7.5	9.5	11.5	20	22	30	37	45
690 VAC without pre-break AC (kW) ⁽¹⁾			12	13	18	22	25.5	34	41
gG DIN⁽²⁾ fuse protected short-circuit withstand									
Prospective short-circuit current (kA rms)		1	8	8	8	8	10	20	20
Associated fuse rating (A)		20	25	32	40	63	80	100	125
Circuit breaker protected short-circuit withstand with any circuit breaker that ensures tripping in less than 0.3s									
Current rated as short-time withstand I_{cw} 0.3s (kA rms)		0.68	0.68	1.28	1.28	2.52	2.52	4	4
Short-circuit operation (switch only)									
Current rated as short-time withstand I_{cw} 1s (kA rms)		0.34	0.34	0.64	0.64	1.26	1.26	2	2
Connection									
Minimum Cu cable cross-section (mm ²)		1.5	2.5	2.5	2.5	2.5	2.5	4	4
Maximum Cu cable cross-section (mm ²)		4	10	10	10	16	25	35	50

(1) The power value is given for information only, the current values vary from one manufacturer to another. (2) For a rated operational voltage $U_e = 415$ VAC.

		SIRCO M / SIRCO										
		20 A	32 A	63 A	100 A	160 A	250 A	400 A	630 A	800 A	1250 A	1600 A
Thermal current I_{th} (40°C)												
Frame size		M1	M1	M2	M3	B3	B4	B5	B5	B6	B7	B7
Enclosed thermal current I_{th} (35°C) (A)		20	32	63	100	160	250	400	630	770	1000	1450
Enclosed thermal current I_{th} (50°C) (A)		17	28	54	86	138	216	345	544	665	863	1252
Rated insulation voltage U_i (V)		800	800	800	800	800	800	1000	1000	1000	1000	1000
Rated impulse withstand voltage U_{imp} (kV)		8	8	8	8	8	8	12	12	12	12	12
Rated operational currents I_e (A)												
Rated voltage	Utilisation category											
415 VAC	AC-22 A / AC-22 B	20	32	63	100	160	250	400	630	800	1250	1600
415 VAC	AC-23 A / AC-23 B	20	32	63	100	160	250	400	500	800	1250	1250
500 VAC	AC-22 A / AC-22 B	20	32	63	100							
500 VAC	AC-23 A / AC-23 B	20	25	63	80							
690 VAC	AC-22 A / AC-22 B	20	32	40/63	80/100							
690 VAC	AC-23 A / AC-23 B	20	25	40	63							
Operational power in AC-23 (kW)												
400 VAC without pre-break AC (kW) ⁽¹⁾		9	15	30	45	80	132	220	280	450	710	710
500 VAC without pre-break AC (kW) ⁽¹⁾		9	15	30	45							
690 VAC without pre-break AC (kW) ⁽¹⁾		11	15	30	45							
gG DIN⁽²⁾ fuse protected short-circuit withstand												
Prospective short-circuit current (kA rms)		50	50	50	25	100	50	100	70	50	100	100
Associated fuse rating (A)		20	32	63	100	160	250	400	630	800	1250	2x800
Circuit breaker protected short-circuit withstand with any circuit breaker that ensures tripping in less than 0.3s												
Current rated as short-time withstand I_{cw} 0.3s (kA rms)		2.5	2.5	3	5	15	17	25	25	50	100	100
Short-circuit operation (switch only)												
Current rated as short-time withstand I_{cw} 1s (kA rms)		1.26	1.26	1.5	2.75	7	9	13	13	35	50	50
Dynamic withstand current in I_{cc} (kA peak) (6)		6	6	9	12	20	30	45	45	55	110	110
Connection												
Minimum Cu cable cross-section (mm ²)		1.5	1.5	2.5	10	50	95	185	2x150	2x185		
Maximum Cu cable cross-section (mm ²)		16	16	35	70	95	150	240	2x300	2x300	4x185	6x185

(1) The power value is given for information only, the current values vary from one manufacturer to another. (2) For a rated operational voltage $U_e = 415$ VAC.

Enclosed switches

Load break switches

20 to 1600 A

COMO dimensions

Size CPC 0

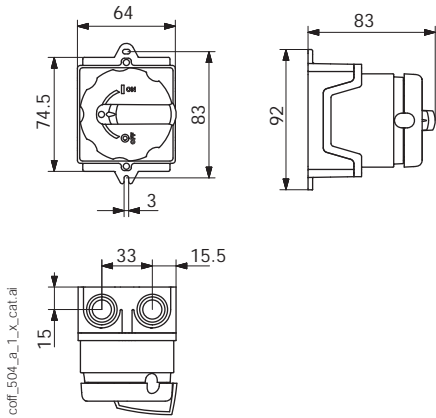

- 2x M25 cable knockouts (top and bottom)

Size CPC 1

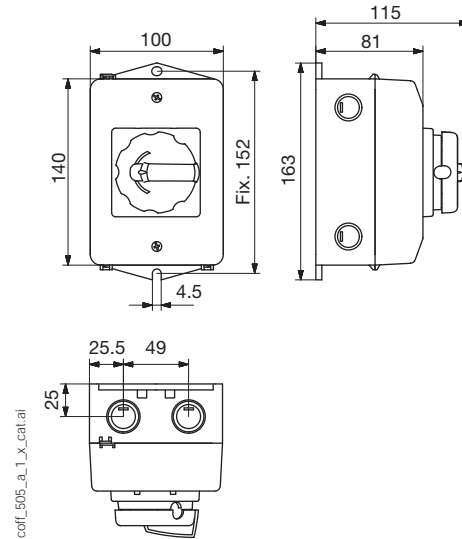

- 2x M20 cable knockouts (on each side)
- 2x M25 cable knockouts (top and bottom)
- 2 pre-drilled holes to expel water

Size CPC 2

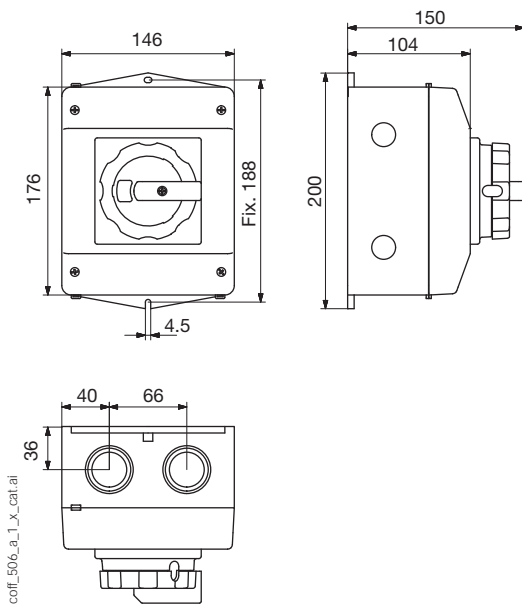

- 2x M20 cable knockouts (on each side)
- 2x M32/M40 cable knockouts (top and bottom)
- 2 pre-drilled holes to expel water

Size CPC 3

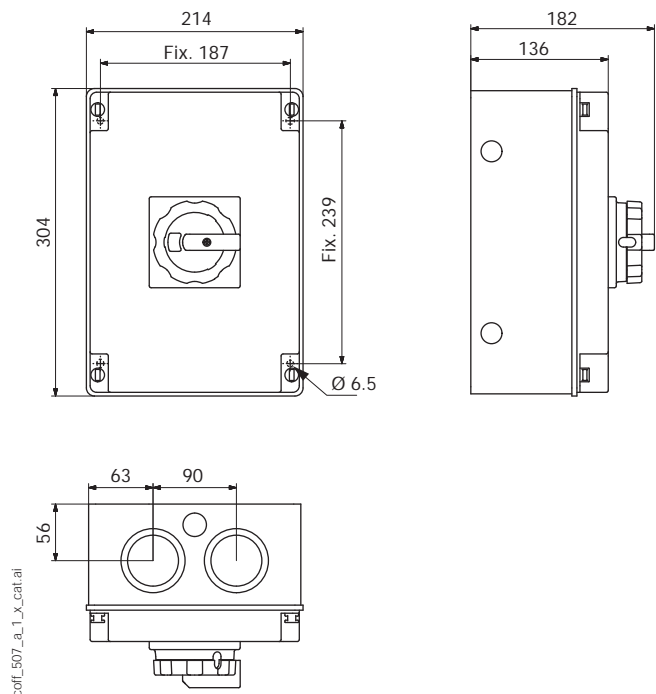

- 2x M20 cable knockouts (on each side)
- 2x M50/M63 cable knockouts (top and bottom)
- 2 pre-drilled holes to expel water

SIRCO M and SIRCO dimensions

Enclosures

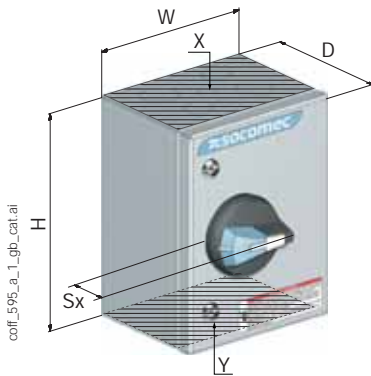

coif_595_a_1_gb_cat.ai

Size	Type	H x W x D (mm)	Sx (mm)	A (mm)	B (mm)	Ø C (mm)	X - Y Cable-in top and bottom ⁽¹⁾
CT 21, CI21, CT 21a	1	200 x 150 x 120	36	135	85	6.5	2 x Ø 25 + 2 x Ø 32 + Ø 16
CT 32, CI32, CT 32a		300 x 200 x 120		235	135		1 x Ø 32 + 2 x Ø 50 + Ø 16
CP 32	3	360 x 270 x 171	45	337	247		-
CP 53		540 x 360 x 171		516	337		
CP 75		720 x 540 x 201		696	516		
CT 43	2	400 x 300 x 210	60	362	262		12.5
CT 66		600 x 600 x 300		562	562	380 x 100	
CT 86		800 x 600 x 350		762	562	660 x 100	
CT 128		1200 x 800 x 300		1162	762		

(1) For stainless steel enclosure, cable-in at bottom only

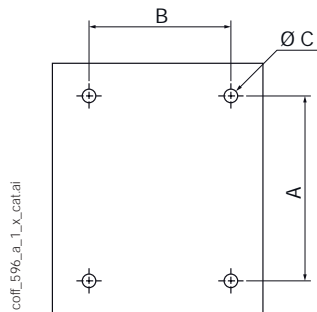

coif_596_a_1_x_cat.ai

Type 1

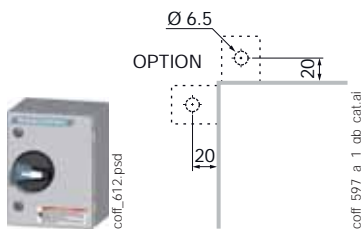

coif_612.psd

coif_597_a_1_gb_cat.ai

Type 2

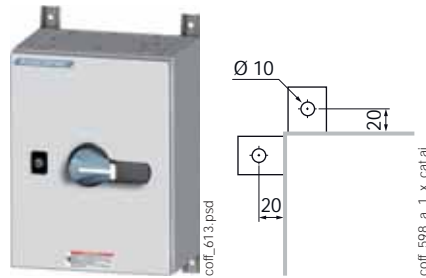

coif_613.psd

coif_598_a_1_x_cat.ai

Type 3

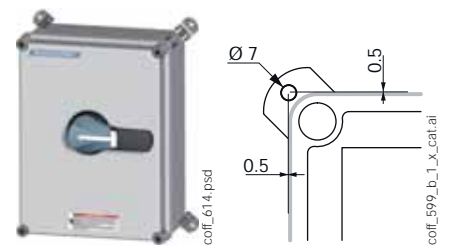

coif_614.psd

coif_599_b_1_x_cat.ai

Enclosed switches

Fuse combination switches

32 to 800 A



*FUSERBLOC enclosure 32 to 63A
Painted steel - IP65*



*FUSERBLOC enclosure 50 to 160A
Polyester - IP55*



*FUSERBLOC enclosure 100 to 800A
Painted steel - IP65*

The solution for

- > OEM
- > Industries
- > Commercial buildings
- > Electrical distribution



Strong points

- > Safe operation
- > Suitable for all kinds of environment
- > Easy setup
- > Extensive range

Compliance with standards

- > IEC 60947-3
- > IEC 60364
- > EN 60947-3
- > EN 61439
- > EN 60204-1



Other products

- > Customised solutions available on request.

Function

Enclosed fuse combination load break switches ensure on-load breaking and making of circuits, protect against overcurrents, and safely isolate all low-voltage electrical circuits by providing protection against contact with live parts and environmental elements, such as dust, water and other hazards.

They enable the shutdown and isolation of the power supply as close to the equipment as possible.

Advantages

Safe operation

- Reliable lockout for safe maintenance procedures.
- On-load breaking.
- Ergonomic operating handle, available in red/yellow or black.
- Triple lock in OFF position.

Suitable for all kinds of environment

- Insulated enclosure for chemical and food processing applications, indoor or outdoor installation.
- Painted steel for areas at risk of impact.

Easy setup

- Cable access top and/or bottom.
- Cable gland knockouts (≤ 100 A).
- Removable gland plates at top and bottom for steel enclosures ≥ 160 A.
- Plenty of room for cabling.

Extensive range

- Standard range.
- Customised products on request.

Fuse combination load break switch in insulated enclosure

■ **FUSERBLOC** in polyester enclosure



coll_584_front.psd

General characteristics

- From 50 to 160 A.
- 3 poles, 4 poles.
- DIN fuse protection (for BS, please contact us).
- Black handle (red/yellow on request).
- Triple lock in OFF position.
- Polyester enclosure.
- Screw-on front.
- Colour: RAL 7035.
- Degree of protection: IP55.
- Wall-mounted, 4 brackets included.

Accessories

- Aux contact open (NO) or closed (NC).
- Blown fuse NO/NC auxiliary contact.
- Terminal shroud.

References

Rating (A)	Case	No. of poles	With black handle	Fuse size (NF, NH)	Auxiliary contacts	Terminal shroud	Blown fuse NO/NC auxiliary contact	Enclosure	
								Size	H x W x D (mm)
50	11	3 P	3117 3005	14 x 51	1 NO AC 3999 0701	-	3994 0405	CP 22	270 X 270 X 171
		4 P	3117 4005						
100	13	3 P	3117 3010	22 x 58	1 NC AC 3999 0702	3998 3016	3994 0310	CP 32	360 X 270 X 171
		4 P	3117 4010			3998 4016	3994 0410		
160	14	3 P	3117 3016	0		3998 3016	3994 0316	CP 52	540 X 270 X 171
		4 P	3117 4016			3998 4016	3994 0416	CP 53	540 X 360 X 171

■ **FUSERBLOC** in metallic enclosure



coll_606_front.psd

General characteristics

- From 32 to 800 A.
- 3 poles + solid neutral, 4 poles.
- DIN fuse protection (for BS, please contact us).
- Black handle (red/yellow on request).
- Triple lock in OFF position.
- Painted steel enclosure.
- Hinged door with double bar locking.
- Colour: RAL 7035.

- Cable gland knockouts (≤ 63 A) or removable gland plates (≥ 100 A) at top and bottom.
- Degree of protection: IP65.
- Wall mounting brackets included (not available for 32 and 63 A).

Accessories

- Aux contact open (NO) or closed (NC).
- Blown fuse NO/NC auxiliary contact.
- Terminal shrouds.

References

Rating (A)	Case	No. of poles	With black handle	Fuse size (NF, NH)	Auxiliary contacts	Terminal shroud	Blown fuse NO/NC auxiliary contact	Bracket kit	Enclosure		
									Size	H x W x D (mm)	Cable-in top and bottom (mm)
32	0	3 P + N	3035 5003	14 x 51		-	-	3031 0011	CT 32a	300 x 250 x 150	$\emptyset 32 + 2 \times \emptyset 50 + \emptyset 16$
		4 P	3035 4003								
63	12	3 P + N	3035 5006	00C		-	-		CT 33	300 x 300 x 150	4 x $\emptyset 32 + \emptyset 16$
		4 P	3035 4006								
100	13	3 P + N	3035 5010	22 x 58		3998 3016	3994 0410		CT 43	400 x 300 x 210	180 x 100
		4 P	3035 4010								
160	13	3 P + N	3035 5016	00	1 NO AC 3999 0701	3998 3016	3899 3380		CT 44	400 x 400 x 210	280 x 100
		4 P	3035 4016								
250	15	3 P + N	3035 5025	1	1 NC AC 3999 0702	3998 3025	3994 0425		CT 64	600 x 400 x 250	280 x 100
		4 P	3035 4025								
400	16	3 P + N	3035 5040	2		3898 3040	3994 0440		CT 66	600 x 600 x 300	380 x 100
		4 P	3035 4040								
630	17	3 P + N	3035 5063	3		3898 3080	3994 1406		CT 108	1000 x 800 x 400	660 x 100
		4 P	3035 4063								
800	18	3 P + N	3035 5080	4		3898 3120	3994 1412				
		4 P	3035 4080						3898 4120	3994 1412	

Enclosed switches

Fuse combination switches

32 to 800 A

Characteristics

Electrical features according to IEC 60947-3

FUSERBLOC										
Thermal current I_{th} (40 °C)	CD 32 A	50 A	63 A	100 A	160 A	160 A	250 A	400 A	630 A	800 A
NFC/DIN fuse size	14 x 51	14 x 51	00C	22 x 58	00	0	1	2	3	4
Switch body size for front and side operation	0	11	12	13	13	14	15	16	17	18
Enclosed thermal current I_{th} (35°C) (A)	32	50	57	100	160	160	240	400	630	800
Enclosed thermal current I_{th} (50°C) (A)	29	48	52	86	138	138	207	345	544	691
Rated insulation voltage U_i (V)	800	800	800	800	800	800	800	1000	1000	1000
Rated impulse withstand voltage U_{imp} (kV)	8	8	8	8	8	8	8	12	12	12
Rated operational currents I_e (A)										
Rated voltage	Utilisation category	A/B ⁽¹⁾	A/B ⁽¹⁾	A/B ⁽¹⁾	A/B ⁽¹⁾	A/B ⁽¹⁾	A/B ⁽¹⁾	A/B ⁽¹⁾	A/B ⁽¹⁾	A/B ⁽¹⁾
400 VAC	AC-22 A / AC-22 B	32/32	50/50	63/63	100/100	160/160	160/160	250/250	400/400	630/630
400 VAC	AC-23 A / AC-23 B	32/32	50/50	63/63	100/100	160/160	160/160	250/250	400/400	630/630
690 VAC	AC-22 A / AC-22 B	32/32	50/50	63/63	100 ⁽²⁾ /100 ⁽²⁾	160 ⁽²⁾ /160 ⁽²⁾	160 ⁽²⁾ /160 ⁽²⁾	250 ⁽²⁾ /250 ⁽²⁾	400/400	500/630
690 VAC	AC-23 A / AC-23 B	32/32	50/50	63/63	100 ⁽²⁾ /100 ⁽²⁾	125 ⁽²⁾ /125 ⁽²⁾	125 ⁽²⁾ /125 ⁽²⁾	250 ⁽²⁾ /250 ⁽²⁾	315/400	315/400
Operational power in AC-23 (kW)										
At 400 VAC without pre-break in AC ⁽¹⁾⁽³⁾		15/15	25/25	30/30	51/51	80/80	80/80	132/132	220/220	355/355
At 690 VAC without pre-break in AC ⁽¹⁾⁽³⁾		25/25	45/45	55/55	90/90	110/110	110/110	220/220	220/295	295/400
Reactive power (kvar)										
At 400 VAC ⁽³⁾		15	23	28	45	75	75	115	185	290
gG DIN fuse protected short-circuit withstand current										
Prospective short-circuit current (kA rms) ⁽⁴⁾		100	100	100	100	50	100	100	100	100
Associated fuse rating (A) ⁽⁴⁾		32	50	63	100	160	160	250	400	630
Short-circuit operation (switch only)										
Rated peak withstand current (kA peak) ⁽⁴⁾		5.5	7.6	10.6	20	20	22.7	32.5	40	70
Connection										
Minimum Cu cable cross-section (mm ²)		2.5	6	10	25	35	50	95	185	2 x 150
Maximum Cu cable cross-section (mm ²)		16	25	25	95	95	95	240	240	2 x 300

(1) Category with index A = frequent operation / Category with index B = infrequent operation.

(2) With terminal shrouds or phase barrier.

(3) The power value is given for information only; the current values vary from one manufacturer to another.

(4) For a rated operational voltage $U_e = 400$ VAC

Dimensions

Enclosures

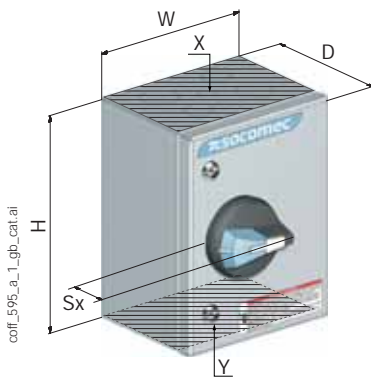

coif_595_a_1_gb_catal

Size	Type	H x W x D (mm)	Sx (mm)	A (mm)	B (mm)	Ø C (mm)	X - Y Cable-in top and bottom ⁽¹⁾
CP 22	3	270 x 270 x 171	45	247	247	6.5	-
CP 32		360 x 270 x 171		337	247		
CP 52		540 x 270 x 171		516	247		
CP 53		540 x 360 x 171		516	337		
CT 32a	1	300 x 250 x 150		262	212	12.5	Ø 32 + 2 x Ø 50 + Ø 16
CT 33		300 x 300 x 150		262	262		4 x Ø 32 + Ø 16
CT 43	2	400 x 300 x 210		362	262	12.5	180 x 100
CT 44		400 x 400 x 210		362	362		280 x 100
CT 64		600 x 400 x 250		562	362		380 x 100
CT 66		600 x 600 x 300		562	562		380 x 100
CT 108		1000 x 800 x 400	962	762	660 x 100		
			962	762	660 x 100		

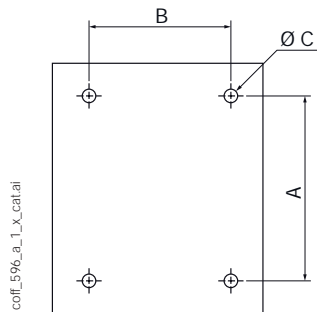

coif_596_a_1_x_catal

Type 1

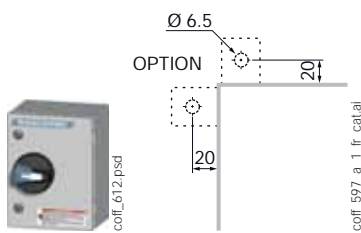

coif_612.psd

coif_597_a_1_fr_catal

Type 2

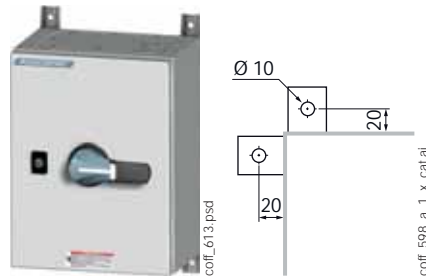

coif_613.psd

coif_598_a_1_x_catal

Type 3

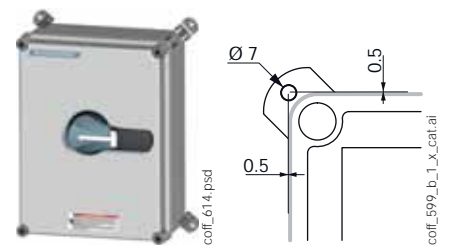

coif_614.psd

coif_599_b_1_x_catal

Safety enclosures

Socomec safety enclosures are designed for installation near a motor or a machine in order to **isolate it from the power supply**.

All the safety enclosures are equipped with **load break switches** with front or side operating handles which are **lockable** in the open position, and with **visible, reliable indication** of the contacts' open position. They make and break under load conditions and provide safety isolation for any low voltage circuit.

During maintenance or inspection operations, the safety enclosures guarantee the operator's **protection against the accidental startup of electrical machines**.

For use in explosive atmospheres, **ATEX dust** enclosures are available to prevent explosions caused by electrical arcs generated when opening or closing the circuits protected by the device.



Site_25B_a

Which ambient atmosphere?

The operating environment is an essential parameter when choosing an enclosure. Our range of enclosures offers you solutions for the most varied of atmospheres, including the most severe.

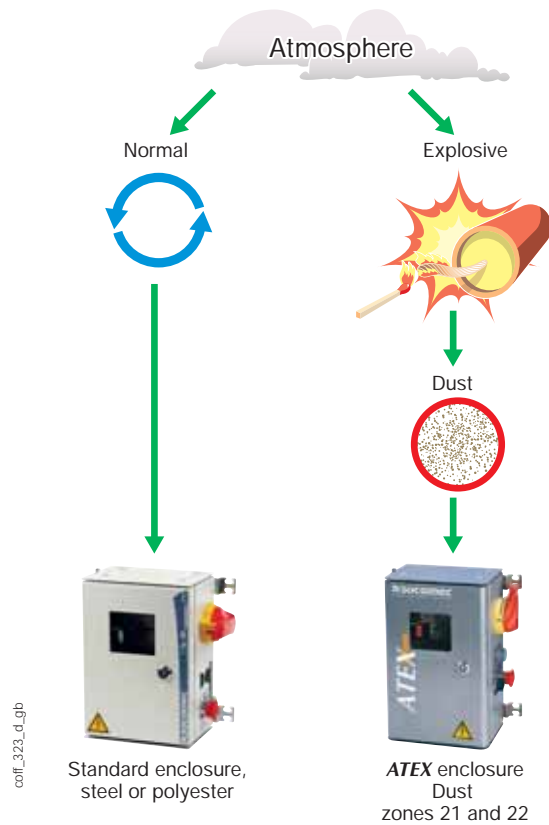

coil_323_d_gb

Environment	Steel enclosure	Polyester enclosure	Stainless steel enclosures ⁽¹⁾	ATEX enclosures
Chemical aggression		•	•	
Mechanical risks	•		•	•
Dust risks	•			•
Contamination risks		•	•	
Atmospheric corrosion		•	•	
Risk of explosion				•

(1) Made to order.

Safety functions

Positive break indication



Clear indication of the open or closed position of the switch via the handle and its clear marking.

Visible breaking

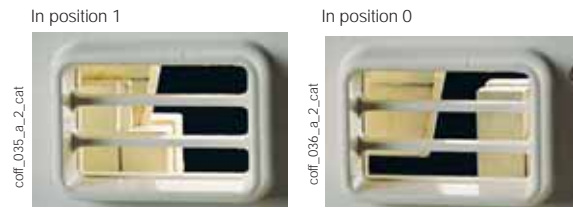

In accordance with IEC 60364, "an isolating device is considered as having visible breaking if the separation of the contacts is directly visible". All the devices used in the safety enclosures have visible breaking.

Padlocking



When working on the machine during the lockout phase, qualified personnel may perform triple handle padlocking in the open position. The ergonomic handle can accommodate up to three locks.

Mechanical flag indicator (optional)



Flush with the viewing window and directly linked to the operating mechanism, this gives clear, at-a-glance indication of contact position, providing easier visualisation of the breaking (standard with steel safety enclosures, optional for polyester).

Double locking

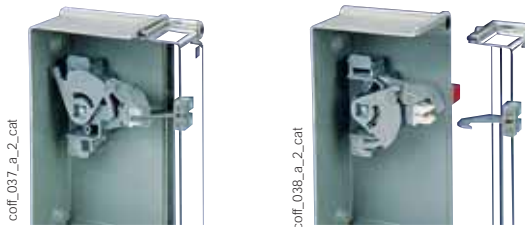

In accordance with standard 60204-1, devices located outside a closed electrical service area must be equipped with the means to allow them to be secured in the OFF position (disconnected state). Qualified personnel may use the ergonomic handle to perform triple handle padlocking.

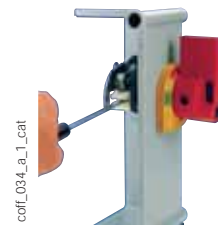

It is possible to close the breaking device when the enclosure door is open by using a tool to inhibit the double lock, thus allowing tests to be carried out by qualified staff.

Overview of our range

For normal atmospheres

Polyester



Steel



For explosive atmospheres

Steel



Enclosed Transfer Switches

ATyS Bypass

40 to 3200 A



The solution for

- > Data centres
- > Energy generation
- > Healthcare buildings
- > High-rise buildings
- > Banks and insurance companies
- > Transport



Strong points

- > No-break bypass solution prevents interruption to the load when switching to bypass.
- > IEC 61439-2 type tested solution
- > Continuity of service for critical and life safety applications

Compliance with standards

- > IEC 61439-2
- > IEC 60947-6-1
- > IEC 60947-3
- > BS 60947-6-1



Expert Services

Technical site audit, solution specification, advice, commissioning, maintenance, training, etc. Our Expert Services extend to a complete offer of customised services to make your project a success.



Function

- Automatically transfers to the available source to ensure continuity of the supply to life safety and critical loads such as sprinklers, firefighting/evacuation lifts, water pumps, etc.
- Assures continuity of service during preventative, maintenance and testing.
- Full isolation of the Automatic Transfer Switch ensures that maintenance work can be carried out safely without interruption to the load.
- Source availability, ATS position & status, and source measurements are displayed on the door-mounted D20 interface. Access to configuration parameters, test and control functions (password protected) is also available via the D20.
- ATS Bypass are required for compliance with installation standards **BS 9999:2017** and **BS 8519:2020**, where occupation of the building is conditional upon the availability of the life safety and fire-fighting equipment.

General features

- 40 to 3200 A, 4-pole.
- 230/400 VAC \pm 20%, 50/60 Hz (ATS is self-powered from incoming sources).
- Class PC Automatic Transfer Switch.
- No-break bypass solution.
- Voltage and frequency monitoring of both sources.
- Phase rotation and neutral position control.
- Bi-stable output relay for genset start/stop command (NO/NC).
- Remote position control (I, 0, II) with dry contact.
- Manual emergency operation.
- Volt-free programmable outputs for BMS/remote indication.
- ATS and bypass switch auxiliary contacts.
- RS485 JBus/Modbus communication (as standard).
- ATS Auto/Manual selector.
- Degree of protection: IP41 as standard (others available on request).
- Hinged door with 3 mm double bar locking.
- Mounting: \leq 160A wall-mounted (brackets supplied loose), \geq 250A floor-mounted on feet.
- D20 remote interface (door-mounted).
- Mimic panel (3 LEDs for live voltage on source 1, source 2, and load; optional 15/17-LED mimic panel).
- Protection against direct contact from each functional unit.
- Enclosure material: Steel.
- Colour: RAL 7035 epoxy powder coating.

2 model versions

ATyS Single Line Bypass

- Comprises an Automatic Transfer Switch and a priority source bypass line. Bypass and isolation of the ATSE can be performed without interruption to the load.

ATyS Double Line Bypass

- Comprises an Automatic Transfer Switch, a priority source bypass

line and an alternative source bypass line. Priority source bypass, and isolation of the ATS, can be performed without interruption to the load.

- The addition of the alternative bypass line allows the backup source to be selected during maintenance work, should the priority source fail. ATyS Double Line Bypass provide an extra layer of power availability for the most critical applications.

ATyS Bypass - SINGLE LINE

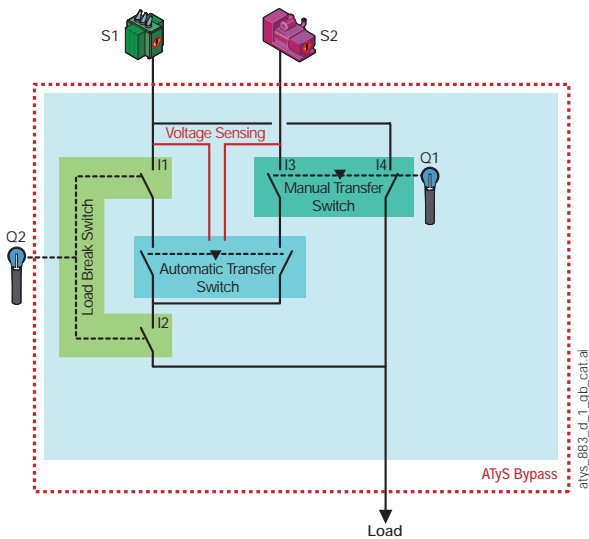

ATyS Bypass - DOUBLE LINE

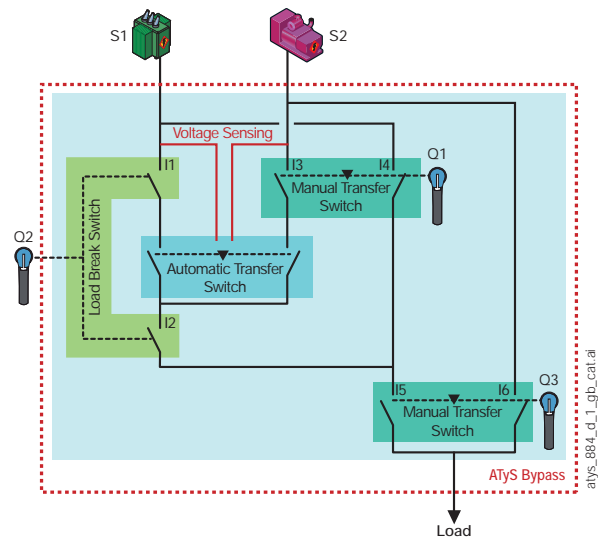

Functions

Normal position:

- The load is supplied by the priority source (S1). In the event of priority source failure, the ATS will automatically transfer to the alternative source (S2) when it is available.

Bypass position:

- Operating Q1 to Bypass creates a direct connection between the priority source (S1) and the load, without causing interruption. Opening switch Q2 provides complete isolation of the ATS from the sources and the load, thereby ensuring maintenance safety.
- Operating Q3 (Double Line only) to Bypass creates a direct connection between the alternative source (S2) and the load.
- While in bypass, tests can be performed ($\geq 160A$) without interruption to the load.

References

Standard device - 230 VAC for ATyS p M

Rating (A)	No. of poles ⁽¹⁾	Single line Reference	Double line Reference
40	4 P	1785 4004	1786 4004
63	4 P	1785 4006	1786 4006
80	4 P	1785 4008	1786 4008
100	4 P	1785 4010	1786 4010
125	4 P	1785 4012	1786 4012

⁽¹⁾ Standard ATyS Bypass require a distributed neutral to power the ATS and other components (230 VAC). If no neutral is available, please contact us for a solution.

Standard device - 230 VAC for ATyS p

Rating (A)	No. of poles ⁽¹⁾	Single line Reference	Double line Reference
160	4 P	1785 4016	1786 4016
250	4 P	1785 4025	1786 4025
400	4 P	1785 4040	1786 4040
630	4 P	1785 4063	1786 4063
800	4 P	1785 4080	1786 4080
1000	4 P	1785 4100	1786 4100
1250	4 P	1785 4120	1786 4120
1600	4 P	1785 4160	1786 4160
2000	4 P	1785 4200	1786 4200
2500	4 P	1785 4250	1786 4250
3200	4 P	1785 4320	1786 4320

⁽¹⁾ Standard ATyS Bypass require a distributed neutral to power the ATS and other components (230 VAC). If no neutral is available, please contact us for a solution.

Enclosed Transfer Switches

ATyS Bypass

40 to 3200 A

Accessories

Customer fit

Designation	Reference
2 input/2 output plug-in programmable output module (ATyS p only)	1599 2001 ⁽¹⁾

(1) Maximum 3 modules can be installed.

Factory-fitted

Cable entry/exit configuration

Use

To permit any cable entry and exit configuration (e.g. top/top), specific mounting brackets (≤ 160 A) or a factory-fitted side extension cabinet (≥ 250 A) can be provided. For ≥ 250 A solutions, power terminals can be factory-mounted within the extension cabinet to facilitate connection. Please contact us for more information.



kdrys_504

Surge protection

Use

Factory-fitted surge protection for either or both incoming sources is available on request.



sgys_069

Load measurement

Use

≥ 160 A: Factory-fit installation of current transformers on the outgoing side of the ATyS Bypass provides current, power and energy load measurements. Available on request.

Tin-plated bars

Use

≥ 250 A: For harsh environments, tinned copper can be factory-fitted in place of the standard copper bars. Please contact us for details.

Signalling

Use

For a full overview of the system's state, opt for a 17-LED (15 for single line bypass) mimic panel (live voltage LED per phase and switch positions). Available on request.

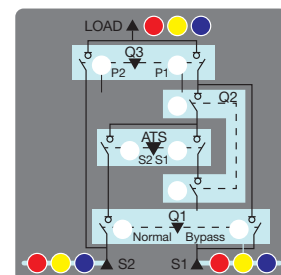

access_275_D_1_x_cat

Factory-fitted (continued)

Connectivity

Use

≤125A: DIRIS Digiware M-70 gateway with WEBVIEW-M (Webserver) can be factory-fitted.

≥160A: Ethernet plug-in module (4825 0203) can be customer-fitted in place of the standard RS485 MODBUS module (plug-in Ethernet module populates 2 of the 4 ATyS p slots).

The above options provide the following:

- Remote Ethernet connectivity with real-time monitoring via a Web browser
- ATS status (position, mode, fault)
- Availability of sources (including measurements)
- Access to ATS parameters (viewing)
- ATS input and output status
- Event history

Easy Config System Software (free download)

allows the following to be performed via Ethernet connectivity:

- ATS parameter configuration ⁽¹⁾
- Controls (remote transfers, auto inhibit, test ON/OFF load) ⁽¹⁾

⁽¹⁾ Password required.

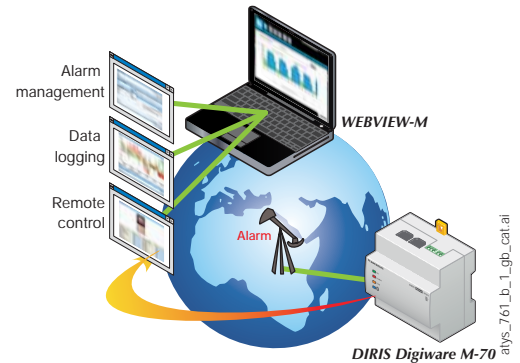

Dimensions

40 to 160 A

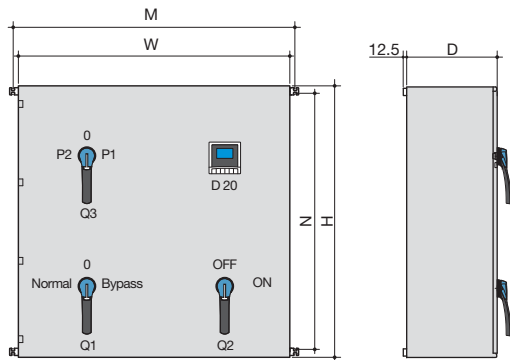

atlys_749_d_1_gb_cat

≥ 250 A

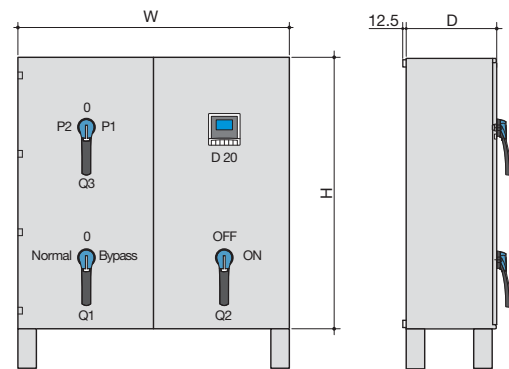

atlys_759_d_1_gb_cat

Wall-mounted

Rating (A)	Recommended cross-section (mm ²)	H (mm)	W (mm)	D (mm)	M (mm)	N (mm)	Weight (kg)
40	10	800	800	300	840	758	80
63	16	800	800	300	840	758	80
80	25	800	800	300	840	758	80
100	35	1000	800	300	840	958	80
125	50	1000	800	300	840	958	80
160	70	1000	800	400	840	958	160

Floor-mounted

Rating (A)	Recommended cross-section (mm ²)	H (mm)	W (mm)	D (mm)	Weight (kg)
250	120	1200 ⁽¹⁾	1000	520	180
400	240	1200 ⁽¹⁾	1000	520	200
630	2 x 185	1600 ⁽²⁾	1200	600	600
800	2 x 240	1800 ⁽²⁾	1600	800	1000
1000	4 x 150	1800 ⁽²⁾	1600	800	1000
1250	4 x 185	2000 ⁽³⁾	2000	1000	2000
1600	4 x 240	2000 ⁽³⁾	2000	1000	2000
2000	8 x 150	2000 ⁽⁴⁾	2200	1000	2500
2500	8 x 185	2000 ⁽⁴⁾	2200	1000	2500
3 200	8 x 240	2000 ⁽⁴⁾	2200	1000	2500

⁽¹⁾ Add 200 mm for the base feet.

⁽²⁾ Add 100 mm for the base feet.

⁽³⁾ Add 125 mm for the base feet.

⁽⁴⁾ Add 120 mm for the base feet (allow for an additional 160 mm for roof fan).

Connection (input/output)

- Standard cable entry and exit is at the bottom. Other configurations may, according to cable size, require specific mounting brackets (≤160A) or a factory-fitted side extension cabinet (≥250A). Please contact us for more information.

Solutions for medical locations

Solution for the continuity and availability of the power supply in Group 2 medical facilities

Standard IEC 60364-7-710 categorises medical facilities into the three following groups, according to the risk of electric shock:

Group 0



Medical facilities which do not have any 'applied parts' intended for use.

What is an 'applied part'?

Standard IEC 60364-7-710 defines an "applied part" as being part of the medical electrical equipment which in normal use

- necessarily comes into physical contact with the patient for the equipment to perform its function, or
- can be brought into contact with the patient, or
- needs to be touched by the patient.

Group 1



Medical facilities in which 'applied parts' are intended for use, as follows:

- externally, or
- invasively across every part of the body, except where Group 2 applies.

Group 2



Medical facilities in which 'applied parts' are intended for use in applications such as medical procedures, surgical procedures and life-saving treatments.

Standard IEC 60364-7-710 also defines the precise continuity of service requirements for the power supply, depending on the type of care being given.

- Class 0: power supply without switching,
- Class 0.5: power available in max. 0.5 s
- Class 15: power available in max. 15 s
- Class >15: power supply available in 15 s or longer

The MEDSYS range

The MEDSYS range meets Class 0, 0.5 or ≤ 15 levels for Groups 0, 1 and 2, as defined in standard IEC 60364-7-710. It is the only IEC 61439-certified and accredited manufacturer solution. MEDSYS also meets European standard HD60364-7-710 and local requirements such as NFC15-211 for France and other countries (please contact us for more information).

From design to maintenance

In addition to its standard products, Socomec has a department dedicated to designing customised systems and meeting the requirements of your project. We support you through the various stages of your project.

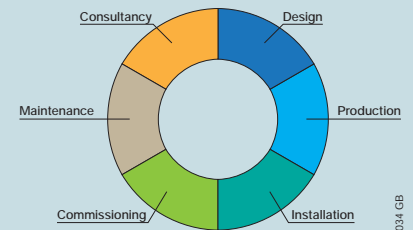

Continuity of service

- Service continuity even in single fault conditions.
- Insulation fault detected in less than 6 seconds even with high-interference equipment present.
- Power availability guaranteed by automatic, static and/or continuous power transfer systems.



Guaranteed safety

- Personal protection against indirect contact (IT system, insulation) and direct contact (IP2X, segregation).
- All device signalling contacts are built-in,
- to back up data to a BMS/CTM.



Improved implementation

- The cabinets are fitted with a pivoting body, for rapid access to all functional units.
- Visual identification of the various compartments.



Technological performance

- Predictive maintenance across your entire IT system (OhmScanner technology integrated into ISOM Digeware).



IoT Ready

- Embedded web technology.
- Remote control/consultation.
- Alarm control and data analytics.



Complete range

- Four versions and eight configurations.
- Solution adapts to the usage conditions and structural properties of Group 2 locations.
- Insulation fault detection and overvoltage protection available for all configurations.



Easy maintenance



- All connections are grouped in a separate compartment.
- Some critical components can be removed (transformer, UPS, static transfer system).



Range of services

To ensure your MEDSYS bay works at its best, Socomec offers expert services including commissioning, troubleshooting and training. Contact your sales branch for more information.

Solutions for medical locations

Selection guide

	Basic configuration		Advanced configuration
	Includes all the equipment required to protect against indirect contact, with a single normal or safety incomer		Includes all the equipment required to protect against indirect contact for 2 normal and safety incomers or 2 safety incomers
			
	MEDSYS 20		MEDSYS 30 Slim
	A	B	A
Inputs			
1 inverter/normal input	•	•	
1 inverter input and 1 spare input			•
2 inverter inputs			•
1 normal input			
2 normal/standby inputs			
Insulation transformer			
Power (kVA)	4	6.3	10
Switched	•	•	
Integrated			•
Headgear			
Load-break switch	•	•	
STATYS Static Transfer System			
ATyS M transfer switch			•
Integrated UPS			
MODULYS or NETYS RT Uninterrupted Power Supply (UPS)			
Distribution			
TN-S		•	•
IT-M (ISOM K-40h)	•	•	•
Alarm report			
ISOM D-15h Alarm notification	•	•	•
Options			
Surge protection device (SURGYS D40)	•	•	•
ISOM Digiware insulation fault detection	Contact us	Contact us	•
Dimensions			
H x W x D (mm)	630 x 403 x 129		1800 x 600 x 220

	Advanced configuration	Full configuration				
	Includes all the equipment required to protect against indirect contact for 2 normal and safety incomers or 2 safety incomers	Includes all the equipment required to protect against indirect contact, with 2 safety incomers	Includes all the equipment required to protect against indirect contacts, with 1 single normal incomer or 2 normal/standby incomer			
						
	MEDSYS 30 CD	MEDSYS 40 CD		MEDSYS 60		
	A	A	B	A	B	C
	•					
	•	•	•			
				•		
					•	•
	10	10	2 x 5	10	10	2 x 10
	•	•	•	•	•	•
				•		
	•	•	•		•	•
				•	•	•
				•	•	•
	•	•	•	•	•	•
	•	•	•	•	•	•
	1800 x 400 x 400	2000 x 600 x 450		2200 x 800 x 800		

Solutions for medical locations

Configuration that adapts as your needs change

Standard IEC 60364-7-710 requires a medical IT system for Group 2 locations and at least one transformer for each operating room or each medical site.

Transformer for the medical IT system

Socomec dry TRM transformers are LV/LV transformers that separate the general distribution network from the medical facility's power supply provided in an IT system. As such, they can isolate and compartmentalise the electrical disturbances across the entire installation.



TRMFO 083

AND

Insulation Monitoring Device and alarm report

The ISOM K-40h insulation monitoring device is a combined unit for monitoring:

- The level of insulation of a medical IT system
- The charging current of single-phase transformers for medical IT systems (up to 50 A)
- The temperature of the medical IT transformer

The D-15h alarm report summarises the alarms from insulation monitoring, overheating and overloads of the medical IT transformer measured by the ISOM K-40h IMD.



ISOM 486



ISOM 484

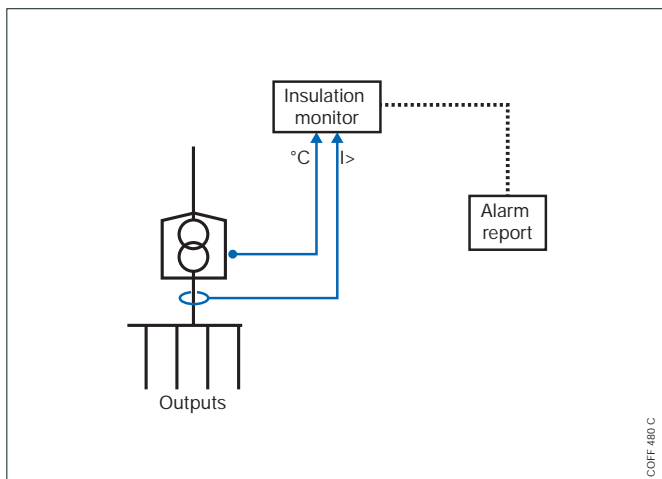

COFF 480 C

Standard IEC 60364-7-710 stipulates that Group 2 medical facilities be powered by 2 separate sources.

Automatic Transfer Switch (ATS)

- ATyS M devices are switching systems that provide automatic transfer between 2 power sources. They have been developed, tested and approved according to criteria defined by the international product standards IEC 60947-3 and IEC 60947-6-1.



ATyS GM 001

OR

Static Transfer System (STS)

- STATYS static transfer systems ensure power supply redundancy between two independent sources while ensuring power continuity to critical applications by choosing the most reliable source. Loads are transferred without interruption in accordance with IEC 62310.



STATY O18



STATY O04

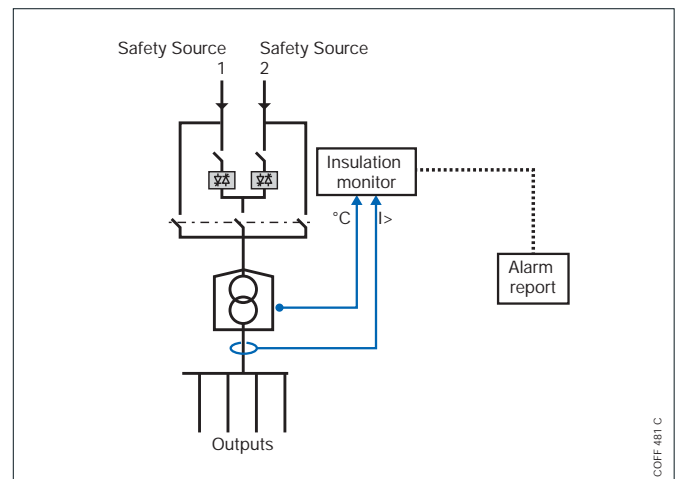

COFF 481 C

Standard IEC 60364-7 stipulates that Group 2 locations must be powered continuously.

Uninterrupted Power Supply (UPS)

The uninterruptible power supply (UPS) NETYS RT ensures continuity of power supply. Double conversion technology ensures the ultimate protection for loads. The rack design means power and/or redundancy can be upgraded as your requirements evolve.



GAMME BF4 A

The document HD 60364-7-710 stipulates the use of a fault location device.

Insulation and multi-measurement monitoring

ISOM Digiware is a 2-in-1 system that combines insulation and multi-measurement monitoring for IT systems. This interconnected system instantly detects and pinpoints any insulation fault. It guarantees continuity of service even for single fault conditions, while protecting people and property.



GAMME T23 A



OhmScanner solution

The OhmScanner detects an insulation fault before it happens. Mapping the insulation of each circuit in detail helps the user to perform predictive maintenance work (available with the ISOM Digiware system).

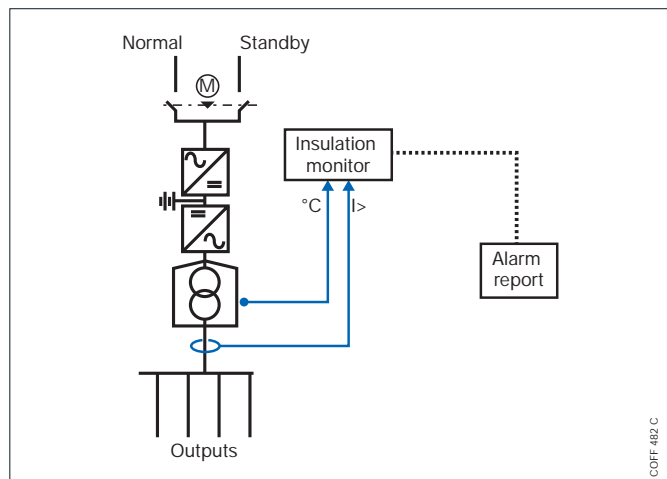

COFF 482 C

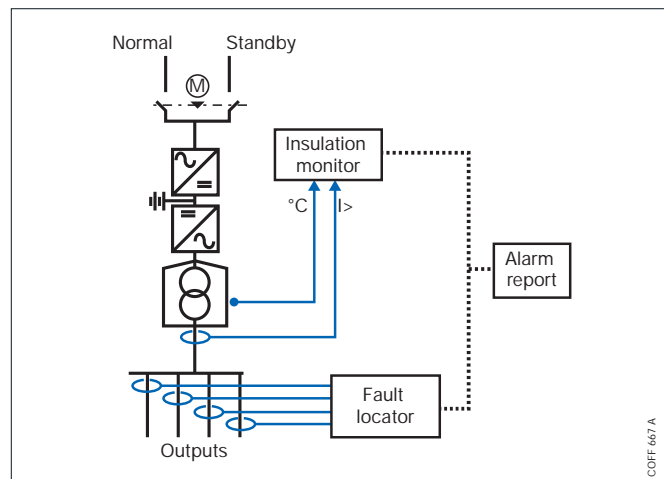

COFF 667 A

References list

References	Pages	References	Pages	References	Pages	References	Pages
110x xxxx	42, 45	1427 xxxx	136, 137, 139	1509 408x	44, 49, 79, 140, 218, 219, 220, 221, 266, 259, 261, 264, 266	192U 23xx	412
111x xxxx	42, 43, 45, 76, 77	1428 xxxx	136, 137, 139, 157, 158, 161			192U 4xxx	412
112x xxxx	44, 45, 76, 77, 218, 219, 220, 221, 222	1429 0000	28, 47, 78, 102, 140, 223			192U 6xxx	413
		1429 7xxx	141	1509 4160	44, 49, 112, 218, 219, 220, 221, 226, 259, 261, 264, 266	192U 8xxx	416
1132 1111	44, 45, 218, 219, 220, 221, 222	142D xxxx	139			192U 9xxx	416
		142E xxxx	139	1509 4200	43, 49, 140, 259, 261, 264, 266	192X 0056	270
1133 1111	44, 45	1433 3111	137, 138, 158, 161, 163			192Y 0015	409, 412
1141 3011	137, 138	1433 3113	220, 222	152x xxxx	270	192Y 0025	409
1142 1111	42, 43, 44, 45, 76, 77, 220, 221, 222, 223	1433 3114	221	1529 0012	114, 270	192Y 0035	412
		1434 3111	137, 138, 158, 161, 163	1529 0080	114, 270	192Y 0045	413, 416
1143 1111	42, 43, 44, 45, 76, 77	1437 3111	139, 158, 161	153x xxxx	265, 270	192Y 0115	409
1309 1xxx	237, 239, 241, 242	1437 7911	137, 160	155x xxxx	261, 264, 268	192Y 0125	409
1309 2xxx	237, 239, 242	1438 xxxx	139, 158, 161	1599 0xxx	259, 261, 264, 270	192Y 0135	412
1309 4xxx	237, 239, 241, 242	143D xxxx	139	1599 2001	264, 271, 506	192Y 0145	413, 416
1309 9xxx	243	143E xxxx	139	1599 2009	244, 265, 272	192Y 0155	409, 412
135x xxxx	239, 242	1443 3111	42, 43, 44, 45, 76, 77, 137, 138, 159, 161, 163	1599 4001	142, 243, 272, 286, 288	192Y 0165	409
1399 4006	31, 237, 239, 241, 242			1599 4064	259, 268	192Y 0175	412
1399 4017	244	1443 3113	218, 222	1599 4121	244	192Y 0185	413, 416
1400 1020	42, 43, 44, 46, 76, 78, 102, 136, 137, 140, 158, 218, 219, 220, 221, 224	1443 3114	219, 222	1599 5xxx	265, 268	192Y 0215	409, 412
		1444 3111	42, 43, 44, 45, 76, 77, 137, 138, 159, 161, 163	1600 0025	282	192Y 0225	409
1400 1025	46	144D xxxx	139	1600 0035	284	192Y 0235	412
1400 1032	42, 43, 44, 46, 76, 78, 101, 102, 136, 137, 140, 157, 158, 161, 218, 220, 221, 224	144E xxxx	139	1600 0055	280, 286	192Y 0245	413, 416
		144E xxxx	139	1600 0065	280, 288	192Y 0265	409
1400 1040	76, 78, 102	1453 8111	43, 45	1609 0001	286	192Y 0275	412
1400 1050	42, 43, 46, 136, 137, 140	1453 8113	218, 222	17xx xxxx	179, 505	192Y 0285	413, 416
1400 1075	46	1454 8111	43, 45	18DC xxxx	111	1999 1xxx	112
1400 12xx	137, 140, 158, 159, 161, 163	146x xxxx	26, 65	18ES xxxx	111	21PV xxxx	64
1401 00xx	46, 139, 223	1471 0xxx	26	19DC xxxx	111	21xx xxxx	491
1401 052x	136, 140	1471 1111	24, 26	19ES xxxx	111	2107 0515	66
1401 053x	136, 140	1473 0111	26	19PV xxxx	111	2107 0516	64
1401 0540	140	1473 0113	24, 26	18xx xxxx	420	2107 0520	66
1401 06xx	28	1473 0114	24, 26	1909 0001	111, 112	2107 0532	66
1401 152x	42, 43, 44, 46, 76, 78, 218, 219, 220, 221, 224	1473 1xxx	24, 26	192J 8015	349, 353, 357	2119 0001	64
		1474 0111	26	192T 0003	409, 411, 412	2119 0012	64
1401 153x	42, 43, 44, 46, 76, 78, 218, 219, 220, 221, 224	1474 1xxx	24, 26	192T 0005	409, 412	2119 1012	64
		147A xxxx	24, 26	192T 0006	411	2119 1412	64
1401 1540	42, 43, 46, 78	147B xxxx	24, 26	192T 0007	411, 412	2119 3312	64
1403 xxxx	27	148x xxxx	24, 27	192T 002x	411	2119 3313	64
1404 0xxx	28	1491 0111	25, 27	192T 0101	409	2129 0001	67
1404 2111	27	1493 0000	46, 78, 139, 223	192T 0102	413, 416	2129 0112	65
1407 xxxx	24, 28	1493 01xx	25, 27	192T 0103	409, 412	2139 1212	65
1409 xxxx	24, 25, 28	1494 xxxx	25, 27	192T 0105	409, 411, 412	2139 3312	65
1411 2111	27, 136, 138, 141, 157	1499 7701	51, 141, 227	192T 0106	413	2139 3313	65
1413 2111	27, 136, 138	1499 7702	51, 141, 227	192T 0255	409, 412	2194 1004	66
1413 2115	136, 138	1499 7703	51, 141	192T 05xx	409	2194 3004	66
1413 2311	138	149A xxxx	25, 27	192T 06xx	409	2200 1000	24, 29
1414 2111	27, 136, 138, 141, 157	149B xxxx	25, 27	192T 08xx	421	2200 1001	24, 29, 492
1414 2115	136, 138	14AA xxxx	102	192T 09xx	421	2200 1002	24, 29
1415 xxxx	27, 136, 139, 157	14AE xxxx	102	192T 14xx	411	2200 1003	24, 29, 492, 494
1417 xxxx	27, 136, 139	14AF 2111	101, 102	192T 19xx	419	2200 1004	24, 29
1418 xxxx	27, 136, 139, 157	14YA 2111	102	192T 20xx	411	2200 1006	24, 29, 492, 494
1419 0000	28	1509 0001	114	192T 21xx	412	2200 1008	24, 29
141A xxxx	27	1509 3012	44, 49, 218, 219, 220, 221, 226, 259, 261, 264, 266	192T 23xx	412	2200 1010	24, 29, 492, 494
141B xxxx	27			192T 24xx	412	2200 1011	24, 29
141D xxxx	139	1509 302x	44, 49, 79, 218, 219, 220, 221, 226, 259, 261, 264, 266	192T 32xx	412	2200 300x	24, 25
141E xxxx	139			192T 33xx	418	2200 3010	24, 25
1421 2111	42, 43, 44, 45, 76, 77, 136, 137, 138, 141, 157, 158, 161	1509 306x	44, 49, 79, 218, 219, 220, 221, 226, 259, 261, 264, 266	192T 34xx	418	2200 3011	24, 25
				192T 40xx	412	2200 3012	25
1421 2113	218, 220, 222	1509 308x	44, 49, 218, 219, 220, 221, 226, 259, 261, 264, 266	192T 46xx	420	2200 3016	25
1423 2111	42, 43, 45, 76, 77, 136, 137, 138	1509 31xx	44, 49, 218, 219, 220, 221, 226, 259, 261, 264, 266	192T 47xx	420	2200 31xx	25
				192T 48xx	420	2200 4xxx	25
1423 2113	218, 220, 222	1509 3200	259, 261, 264, 266	192T 5xxx	413	2200 5xxx	25, 29
1423 2114	219, 221, 222	1509 401x	44, 49, 112, 218, 219, 220, 221, 226, 259, 261, 264, 266	192T 6xxx	413	2200 9xxx	25, 29
1423 2115	136, 137, 138			192T 7xxx	416	2205 xxxx	24, 25
1423 2311	138	1509 402x	44, 49, 112, 218, 219, 220, 221, 226, 259, 261, 264, 266	192T 80xx	416	2209 xxxx	30
1423 2813	227			192T 81xx	413	226x xxxx	30
1424 2111	42, 43, 44, 45, 76, 77, 136, 137, 138, 141, 157, 158, 161	1509 406x	44, 49, 79, 140, 218, 219, 220, 221, 226, 259, 261, 264, 266	192T 93xx	416	2294 1005	25, 29, 492, 494
				192T 95xx	413	2294 1009	25, 29, 494
1424 2115	136, 137, 138			192T 96xx	413	2294 101x	25, 29, 492, 494
1425 xxxx	136, 137, 139, 157, 158, 161			192T 97xx	416	2294 3xxx	25, 29, 492, 494
				192U 0xxx	409	2294 4016	25, 29, 237, 239, 241, 242
				192U 22xx	411	2299 0xxx	25, 30, 492, 494

References	Pages
2299 3xxx	25, 31
2299 501x	24, 26
2299 5022	25, 26
2299 5032	24, 26
2299 5042	25, 26
2299 6xxx	30
2299 9xxx	31
2600 xxxx	42
2601 xxxx	44
2609 0025	76, 80, 112
2609 0026	76, 81
2609 0027	111
2609 004x	76, 81
2609 0080	111, 112
2609 1xxx	76, 80, 82, 111, 112
2609 2xxx	111, 112
261x xxxx	50, 225, 267
262x xxxx	50, 225, 267
263x xxxx	50, 225, 267
2694 3014	42, 44, 48, 218, 219, 220, 221, 226, 259, 261, 264, 266
2694 302x	42, 43, 44, 48, 218, 219, 220, 221, 226, 259, 261, 264, 266
2694 305x	42, 43, 44, 48, 218, 219, 220, 221, 226, 259, 261, 264, 266
2694 4014	42, 44, 48, 218, 219, 220, 221, 226, 259, 261, 264, 266
2694 402x	42, 43, 44, 48, 113, 218, 219, 220, 221, 226, 259, 261, 264, 266
2694 405x	42, 43, 44, 48, 113, 218, 219, 220, 221, 226, 259, 261, 264, 266
2698 3012	42, 49, 492, 493
2698 302x	42, 43, 49, 79, 492, 493
2698 305x	42, 43, 49, 79, 492, 493
2698 308x	42, 43, 49, 493
2698 31xx	42, 43, 49, 493
2698 3200	42, 43, 49
2698 4012	42, 49, 492, 493
2698 402x	42, 43, 49, 79, 492, 493
2698 405x	42, 43, 49, 79, 492, 493
2698 408x	42, 43, 49, 79, 493
2698 41xx	42, 43, 49, 79, 493
2698 4200	42, 43, 49, 79
2699 003x	42, 43, 47, 79, 492, 493
2699 006x	44, 47, 79
2699 01xx	47
2699 03xx	47, 79
2699 1200	50, 225, 267
2699 1201	225, 267
2699 5xxx	77
2699 6xxx	51
2699 9xxx	51
26Ax xxxx	43
26PV 201x	76, 83
26PV 202x	76, 83
26PV 2031	76, 84
26PV 301x	76, 81, 83
26PV 302x	76, 81, 83
26PV 3030	76, 81, 84
26PV 3039	76, 81, 85
26PV 404x	76, 80, 85
26PV 405x	76, 80, 85
26PV 406x	76, 80, 86
26PV 408x	76, 80, 86
26PV 41xx	76, 80, 87
26PV 42xx	76, 80, 87
26PV 43xx	76, 80, 87
26PV 501x	76, 83
26PV 502x	76, 83
26PV 5031	76, 84

References	Pages
26PV 8063	76, 80, 86
26PV 8080	76, 80, 82, 86
26PV 81xx	76, 80, 82, 87
26PV 82xx	76, 80, 82, 87
2709 0027	76, 80
2799 3015	42, 43, 46, 218, 220, 221, 224
2799 3018	42, 43, 44, 46, 76, 78, 218, 220, 221, 224
2799 3019	43, 46, 76, 78, 218, 220, 221, 224
2799 700x	51, 227
2799 7042	42, 43, 45, 218, 222
2799 7043	42, 43, 45
2799 707x	42, 43, 45
2799 713x	42, 45
2799 7145	44, 45, 76, 77
2799 7155	42, 43, 45
2998 0013	47, 226, 266
2998 0014	47, 79, 111, 113, 226, 266
2998 002x	47, 79, 111, 113, 226, 266
2998 003x	47, 226, 266
2999 8707	51
3031 0011	492, 499
3031 0012	494
3032 4xxx	493
3032 500x	492
3032 5010	492
3032 5016	493
3032 502x	493
3032 504x	493
3032 506x	493
3032 508x	493
3032 51xx	492
3032 52xx	492
3032 53xx	492
3032 8xxx	494
3035 xxxx	499
3116 xxxx	492
3117 xxxx	499
36Ux xxxx	160
361x xxxx	157, 158
3629 4012	136, 138
3629 4013	138
3629 7900	157
3629 7901	157, 158, 160
3629 9xxx	142
363x xxxx	136
368x xxxx	159
369x xxxx	479
36Ux xxxx	160
38DR xxxx	163, 164
38Ux xxxx	161
3811 xxxx	137, 158
3819 xxxx	144
3829 91xx	144
3829 93xx	142
3831 200x	136, 157
3831 2010	136
3831 2011	136, 157
3831 2012	136
3831 2015	137, 158
3831 2016	137, 158
3831 202x	137, 158
3831 203x	137
3831 300x	136, 157
3831 3010	136
3831 3011	136, 157
3831 3012	136
3831 3015	137, 158
3831 3016	137, 158
3831 302x	137
3831 303x	137, 158

References	Pages
3831 600x	136, 157
3831 6010	136
3831 6011	136, 157
3831 6012	136
3831 6015	137, 158
3831 6016	137, 158
3831 602x	137
3831 603x	137
3890 xxxx	158, 159, 160
3894 xxxx	144
3898 2xxx	137, 142, 160, 161, 163
3898 3xxx	137, 142, 499, 160, 161
3898 4xxx	137, 142, 499
389x xxxx	161, 164
3899 0400	141
3899 3120	136, 137, 144
3899 3380	136, 137, 144, 499
3899 6011	137, 138, 158, 160, 163
3899 7011	160, 163
399x xxxx	158, 159, 160, 161, 164
3994 02xx	144
3994 030x	144
3994 031x	144, 499
3994 0325	144
3994 040x	144, 499
3994 041x	144, 499
3994 042x	144, 499
3994 044x	499
3994 14xx	499
3994 19xx	144, 177
3998 2016	136, 137, 142, 163, 177
3998 2025	137, 142, 161, 163, 177
3998 3016	136, 137, 142, 177, 499
3998 3025	137, 142, 231, 177, 499
3998 3063	159
3998 3120	159
3998 4016	136, 137, 142, 177, 499
3998 4025	137, 142, 177, 499
3998 4063	159
3998 4120	159
3999 00xx	143, 157, 158, 159, 161
3999 01xx	143
3999 02xx	143, 158
3999 06xx	143
3999 070x	25, 30, 136, 137, 143, 157, 158, 163, 499
3999 0710	143
3999 5020	136, 137, 138
3999 5021	137, 138
3999 6012	159
4109 0019	218, 259, 261, 264, 267
4109 0021	218, 219, 220, 221, 225
4109 0025	218, 259, 261, 264, 267
4109 003x	218, 259, 261, 264, 267
4109 005x	218, 259, 261, 264, 267
4109 006x	218, 259, 261, 264, 267
4109 008x	218, 259, 261, 264, 267
4109 01xx	218, 259, 261, 264, 267
4109 0120	111, 112, 218
4109 0320	225, 267
4109 1xxx	227
4109 2xxx	227
4109 301x	219, 220, 221, 224
4109 302x	219, 220, 221, 224
4109 303x	219, 220, 221, 224
4109 3050	224
4109 306x	219, 220, 221, 224
4109 308x	219, 220, 221, 224
4109 31xx	219, 220, 221, 224
4109 401x	219, 220, 221, 224
4109 402x	219, 220, 221, 224
4109 403x	219, 220, 221, 224

References	Pages
4109 4050	224
4109 406x	219, 220, 221, 224
4109 408x	219, 220, 221, 224
4109 41xx	219, 220, 221, 224
4109 8507	51
4190 xxxx	219
4199 3018	76, 78
4199 3019	78
4199 7146	220, 221, 222
41AC 3xxx	218
41AC 4xxx	218
41AC 7xxx	220
41AC 9xxx	220
4320 xxxx	211
4321 xxxx	212
4330 xxxx	211
4331 xxxx	212
435x xxxx	211
46xx xxxx	221
4729 02xx	307
4729 0603	307, 313
4825 002x	367
4825 0080	371
4825 0082	371
4825 0083	371
4825 0088	363, 371, 377
4825 0089	371, 377
4825 0090	264, 271, 377
4825 0092	264, 271, 377
4825 0093	264, 271, 377
4825 0094	377
4825 0097	377
4825 0203	264, 271, 377
4825 0204	264, 271, 377
4825 0205	377
4825 0206	377
4825 0208	377
4825 0209	377
4825 0400	363
4825 0401	363
4825 0402	371
4825 0403	377
4825 0404	377
4825 0405	377
4825 0406	377
4825 0500	381
4825 0501	381, 425
4825 0502	381
4826 0100	391
4829 000x	389
4829 001x	389
4829 003x	389, 401
4829 004x	389
4829 0050	301, 307, 313, 315, 319, 323, 337, 389, 401
4829 0101	307
4829 0102	315
4829 0103	307
4829 0105	315
4829 0106	315
4829 0110	323
4829 0111	323
4829 0112	323
4829 0113	323
4829 0114	335
4829 0120	307, 313
4829 0128	323
4829 0129	323
4829 013x	323
4829 014x	337
4829 016x	319
4829 018x	307, 313, 315, 319, 323, 337

References list

References	Pages	References	Pages	References	Pages	References	Pages
4829 0190	301, 307, 313, 315, 319, 323, 337	4850 3065	349	5412 xxxx	479	6053 xxxx	181
4829 0195	319	4850 3066	349	5413 xxxx	481	6062 xxxx	181
4829 0196	319	4850 3067	349	5414 xxxx	477	6063 xxxx	181
4829 0200	307, 389, 401	4850 3068	349	5420 xxxx	478	63xx xxxx	177
4829 0203	286, 288, 383, 425	4850 306U	343	5421 0xxx	478	64xx xxxx	142, 164, 178, 182, 183, 184
4829 0204	286, 288, 307	4850 307U	347	5421 100x	478	65PV xxxx	193
4829 0206	301	4850 309U	345, 349	5421 1010	477	65xx xxxx	175, 176, 193
4829 0207	301	4853 xxxx	353	5421 1012	477	66xx xxxx	182, 183
4829 021x	313	4854 xxxx	425	5421 1013	477	67xx xxxx	182, 183
4829 0220	313	4899 0011	371, 377	5421 1016	478	68xx xxxx	182, 183
4829 0221	286, 288, 313	4941 36xx	435	5421 11xx	478	73xx xxxx	178
4829 0222	286, 288, 313, 425	4941 3723	435	5421 2xxx	478	742F 2111	101, 102
4829 0230	307	4941 3724	437	5421 4xxx	477	7769 9999	145
4829 028x	389, 401	4941 3740	435	54Ux xxxx	475	840x xxxx	103
4829 050x	327	4941 3741	437	56PV xxxx	191, 196	8499 0001	101, 103
4829 055x	329	4942 xxxx	439	56xx xxxx	367, 371	8499 0002	103
4829 057x	331	500x xxxx	31	57PV 0001	191	8499 2xxx	104
4829 058x	327, 329, 331, 335	5020 1xxx	447	57PV 0L01	191	8499 3xxx	104
4829 0590	327, 329, 331, 335	5020 2xxx	446	5701 0015	169	8499 4xxx	104
4829 0591	327, 329, 331, 335	5021 xxxx	466	5701 0016	169	8499 5xxx	102
4829 0592	327, 329, 331, 335	5022 xxxx	466	5701 0017	169, 307, 313, 351, 353, 363, 377, 381, 389	8499 6xxx	105
4829 0593	327, 329, 331, 335	5023 011x	466	5701 0018	169, 349, 351, 363, 377, 381, 389	8499 9xxx	105
4829 0594	327, 329, 331, 335	5023 015x	460	5701 0019	169, 315	86xx xxxx	101
4829 0595	327, 329, 331, 335	5023 03xx	460	5701 0020	169	932x xxxx	237
4829 0596	327, 329, 331, 335	5023 04xx	460	5701 5005	169	934x xxxx	239
4829 0597	327, 329, 331, 335	5023 6110	466	5702 5000	169	935x xxxx	239
4829 0598	327	5024 4xxx	446	5702 5001	169, 341	936x xxxx	241
4829 0599	327	5024 5xxx	446	5702 5002	169	938x xxxx	241
4829 0600	327	5024 6xxx	446	5702 5003	169	9503 xxxx	251
4829 0601	327, 329, 331, 335	5024 7xxx	446	5702 5004	169	9505 xxxx	251
4829 0602	327, 329, 331, 335	5024 8xxx	446	5702 5006	169	9506 xxxx	251
4829 0603	301, 327, 329, 331, 335	5024 9000	448	5702 5007	169	9509 0002	252
4829 0605	323	5024 9001	448	5702 5011	169	9509 4013	251
4829 0606	327, 329, 331, 335	5024 9002	460	5702 5012	169	9509 5xxx	273
4829 0620	335	5024 903x	448	5702 5013	169	951x xxxx	251
4829 065x	329	5024 904x	448	5702 5014	169	9523 xxxx	259
4829 0670	331	5024 905x	447	5702 5016	169	9529 xxxx	269
4829 09xx	401	5025 xxxx	456	5702 5017	171	9533 xxxx	280
4850 300x	347	5026 041x	472	5702 9020	171	9539 2001	272
4850 3010	351	5026 045x	472	5702 9030	170	9553 xxxx	261
4850 3011	351	5026 046x	460	5702 9040	171	9559 2001	273
4850 3012	347	5027 xxxx	460	5702 9901	170	9573 xxxx	264, 265
4850 3013	347	5028 0410	472	5702 9903	170	9579 2001	273
4850 302x	347	5028 0411	472, 480	5703 5000	169	9594 xxxx	251, 252
4850 303x	341	5028 0412	480	5703 5001	169, 343	9599 0000	272
4850 3040	341	5028 0413	472, 480	5703 5002	169	9599 0003	113, 259, 265, 270
4850 3041	341	5028 0415	480	5703 5003	169, 345, 347	9599 0004	113, 259, 265, 270
4850 3042	341	5028 042x	480	5703 5004	169	9599 1004	114, 265, 270
4850 3043	343	5028 045x	480	5703 5006	169	9599 1006	114, 265, 270
4850 3044	343	5028 047x	480	5703 5011	169	9599 1007	272
4850 3045	343	503x xxxx	466	5703 5012	169	9599 1008	273
4850 3046	343	5119 44xx	449	5703 5013	169	9599 2010	241, 244, 272
4850 3047	343	5119 45xx	449	5703 5014	169	9599 2020	241, 244, 265, 272
4850 3048	343	5119 46xx	460	5703 5016	169	9599 4001	251
4850 3049	345	5400 301x	49, 145	5703 9030	170	9599 4002	251, 252
4850 3050	345	5400 302x	49, 145	5703 9901	170	9599 4003	251
4850 3051	345	5400 304x	49, 145	5703 9903	170	9599 4004	252
4850 3052	345	5400 3063	49	5704 0003	171	9599 402x	269
4850 3053	345	5400 401x	49, 145	60PV xxxx	196	9599 404x	269
4850 3054	345	5400 402x	49, 145	65PV xxxx	196	9599 406x	269
4850 3055	345	5400 404x	49, 145	6012 xxxx	181, 307, 313, 315, 349, 351, 353, 363, 367, 371, 377, 381, 389	9599 5012	252
4850 3056	349	5400 4063	49	6013 xxxx	181	99xx xxxx	125
4850 3057	349	5410 xxxx	476	6019 xxxx	181, 184	NBxx xxxx	480
4850 3058	341	5411 0xxx	476	6022 xxxx	181, 341		
4850 3059	341	5411 1xxx	476	6023 xxxx	181		
4850 305U	341	5411 3016	48, 481	6029 xxxx	142, 181, 184		
4850 3060	343	5411 3017	478	6032 xxxx	181, 343, 345, 347		
4850 3061	343	5411 302x	48, 481	6033 xxxx	181		
4850 3062	345	5411 304x	48, 481	6039 xxxx	142, 181, 184		
4850 3063	349	5411 306x	48, 481	6052 xxxx	181		
4850 3064	349	5411 40xx	48, 481				
		5411 4112	478				

Model: SOCOMEC
Production: SOCOMEC
Photography: Martin Bernhart et Studio Objectif
Printing: BDZ - Centre d'impression - Buchdruck Zentrum
1, Hauptstrooss
9753 Heinerscheid
Luxembourg



Socomec: our innovations supporting your energy performance

1 independent manufacturer

3,600 employees
worldwide

10 % of sales revenue
dedicated to R&D

400 experts
dedicated to service provision

Your power management expert



POWER
SWITCHING



POWER
MONITORING



POWER
CONVERSION



ENERGY
STORAGE



EXPERT
SERVICES

The specialist for critical applications

- Control, command of LV facilities
- Safety of persons and assets
- Measurement of electrical parameters
- Energy management
- Energy quality
- Energy availability
- Energy storage
- Prevention and repairs
- Measurement and analysis
- Optimisation
- Consultancy, commissioning and training

A worldwide presence

12 production sites

- France (x3)
- Italy (x2)
- Tunisia
- India
- China (x2)
- USA (x3)

28 subsidiaries and commercial locations

- Algeria • Australia • Belgium • China • Canada
- Dubai (United Arab Emirates) • France • Germany
- India • Indonesia • Italy • Ivory Coast • Netherlands
- Poland • Portugal • Romania • Serbia • Singapore
- Slovenia • South Africa • Spain • Switzerland
- Thailand • Tunisia • Turkey • UK • USA

80 countries

where our brand is distributed

HEAD OFFICE

SOCOMEK GROUP

SAS SOCOMEK capital 10 607 040 €
R.C.S. Strasbourg B 548 500 149
B.P. 60010 - 1, rue de Westhouse
F-67235 Benfeld Cedex
Tel. +33 3 88 57 41 41 - Fax +33 3 88 57 78 78
info.scp.isd@socomec.com

YOUR DISTRIBUTOR / PARTNER

www.socomec.com



100 years
OF SHARED ENERGY
1922 — 2022

socomec
Innovative Power Solutions